

A Few Words About Safety

Service information

The service and repair information contained in this manual is intended for use by qualified, professional technicians. Attempting service or repairs without the proper training, tools, and equipment could cause injury to you or others. It could also damage the vehicle or create an unsafe condition.

This manual describes the proper methods and procedures for performing service, maintenance, and repairs. Some procedures require the use of specially designed tools and dedicated equipment. Any person who intends to use a replacement part, service procedure or a tool that is not recommended by Honda, must determine the risks to their personal safety and the safe operation of the vehicle.

If you need to replace a part, use genuine Honda parts with the correct part number or an equivalent part. We strongly recommended that you do not use replacement parts of inferior quality.

For Your Customer's Safety

Proper service and maintenance are essential to the customer's safety and the reliability of the vehicle. Any error or oversight while servicing a vehicle can result in faulty operation, damage to the vehicle, or injury to others.

⚠ WARNING

Improper service or repairs can create an unsafe condition that can cause your customer or others to be seriously hurt or killed.

Follow the procedures and precautions in this manual and other service materials carefully.

For Your Safety

Because this manual is intended for the professional service technician, we do not provide warnings about many basic shop safety practices (e. g., Hot parts - wear gloves). If you have not received shop safety training or do not feel confident about your knowledge of safe servicing practice, we recommended that you do not attempt to perform the procedures described in this manual.

Some of the most important general service safety precautions are given below. However, we cannot warn you of every conceivable hazard that can arise in performing service and repair procedures. Only you can decide whether or not you should perform a given task.

⚠ WARNING

Failure to properly follow instructions and precautions can cause you to be seriously hurt or killed.

Follow the procedures and precautions in this manual carefully.

Important Safety Precautions

Make sure you have a clear understanding of all basic shop safety practices and that you are wearing appropriate clothing and using safety equipment. When performing any service task, be especially careful of the following:

- Read all of the instructions before you begin, and make sure you have the tools, the replacement or repair parts, and the skills required to perform the tasks safely and completely.
- Protect your eyes by using proper safety glasses, goggles or face shields any time you hammer, drill, grind, pry or work around pressurized air or liquids, and springs or other stored-energy components. If there is any doubt, put on eye protection.

- Use other protective wear when necessary, for example gloves or safety shoes. Handling hot or sharp parts can cause severe burns or cuts. Before you grab something that looks like it can hurt you, stop and put on gloves.
- Protect yourself and others whenever you have the vehicle up in the air. Any time you lift the vehicle, either with a hoist or a jack, make sure that it is always securely supported. Use jack stands.

Make sure the engine is off before you begin any servicing procedures, unless the instruction tells you to do otherwise. This will help eliminate several potential hazards:

- Injury from moving parts. If the instruction tells you to run the engine, be sure your hands, fingers and clothing are out of the way.



Gasoline vapors and hydrogen gases from batteries are explosive. To reduce the possibility of a fire or explosion, be careful when working around gasoline or batteries.

- Use only a nonflammable solvent, not gasoline, to clean parts.
- Never drain or store gasoline in an open container.
- Keep all cigarettes sparks and flames away from the battery and all fuel-related parts.

Your safety, and the safety of others, is very important. To help you make informed decisions we have provided safety messages and other information throughout this manual. Of course, it is not practical or possible to warn you about all the hazards associated with servicing this vehicle. You must use your own good judgment.

You will find important safety information in a variety of forms including:

- Safety Labels - on the vehicle
- Safety Messages preceded by a safety alert symbol  and one of three signal words, DANGER, WARNING, or CAUTION. These signal words mean:

 DANGER	You WILL be KILLED or SERIOUSLY HURT if you don't follow instructions.
 WARNING	You CAN be KILLED or SERIOUSLY HURT if you don't follow instructions.
 CAUTION	You CAN be HURT if you don't follow instructions.

- Instructions - on how to service this vehicle correctly and safely.

As you read this manual, you will find information that is preceded by a **NOTICE** symbol. The purpose of this message is to help prevent damage to your vehicle, other property, or the environment.

ALL INFORMATION, ILLUSTRATIONS, DIRECTIONS AND SPECIFICATIONS INCLUDED IN THIS PUBLICATION ARE BASED ON THE LATEST PRODUCT INFORMATION AVAILABLE AT THE TIME OF APPROVAL FOR PRINTING. HONDA MOTOR CO., LTD. RESERVES THE RIGHT TO MAKE CHANGES AT ANY TIME WITHOUT NOTICE AND WITHOUT INCURRING ANY OBLIGATION WHATSOEVER. NO PART OF THIS PUBLICATION MAY BE REPRODUCED WITHOUT WRITTEN PERMISSION. THIS MANUAL IS WRITTEN FOR PERSONS WHO HAVE ACQUIRED BASIC KNOWLEDGE OF MAINTENANCE ON HONDA MOTORCYCLES, MOTOR SCOOTERS OR ATVS.

1. GENERAL INFORMATION

SERVICE RULES	1-2	REAR WHEEL/SUSPENSION SPECIFICATIONS	1-10
MODEL IDENTIFICATION	1-2	HYDRAULIC BRAKE SPECIFICATIONS	1-11
GENERAL SPECIFICATIONS	1-5	BATTERY/CHARGING SYSTEM SPECIFICATIONS	1-11
LUBRICATION SYSTEM SPECIFICATIONS ·	1-7	IGNITION SYSTEM SPECIFICATIONS	1-11
FUEL SYSTEM	1-7	ELECTRIC STARTER SPECIFICATIONS	1-11
COOLING SYSTEM SPECIFICATIONS	1-7	LIGHTS/METERS/SWITCHES SPECIFICATIONS ('04 model)	1-12
CYLINDER HEAD/VALVES SPECIFICATIONS	1-8	LIGHTS/METERS/SWITCHES SPECIFICATIONS (After '04 model)	1-12
CLUTCH/GEARSHIFT LINKAGE SPECIFICATIONS	1-8	STANDARD TORQUE VALUES	1-13
ALTERNATOR/STARTER CLUTCH SPECIFICATIONS	1-8	ENGINE & FRAME TORQUE VALUES	1-13
CRANKCASE/TRANSMISSION SPECIFICATIONS	1-9	LUBRICATION & SEAL POINTS	1-19
CRANKSHAFT/PISTON/CYLINDER SPECIFICATIONS	1-9	CABLE & HARNESS ROUTING	1-23
FRONT WHEEL/SUSPENSION/STEERING SPECIFICATIONS	1-10	EMISSION CONTROL SYSTEMS	1-48
		EMISSION CONTROL INFORMATION LABELS	1-51

GENERAL INFORMATION

SERVICE RULES

1. Use genuine Honda or Honda-recommended parts and lubricants or their equivalents. Parts that don't meet Honda's design specifications may cause damage to the motorcycle.
2. Use the special tools designed for this product to avoid damage and incorrect assembly.
3. Use only metric tools when servicing the motorcycle. Metric bolts, nuts and screws are not interchangeable with English fasteners.
4. Install new gaskets, O-rings, cotter pins, and lock plates when reassembling.
5. When tightening bolts or nuts, begin with the larger diameter or inner bolt first. Then tighten to the specified torque diagonally in incremental steps unless a particular sequence is specified.
6. Clean parts in cleaning solvent upon disassembly. Lubricate any sliding surfaces before reassembly.
7. After reassembly, check all parts for proper installation and operation.
8. Route all electrical wires as show in the Cable and Harness Routing (page 1-23).

MODEL IDENTIFICATION

'04 model:

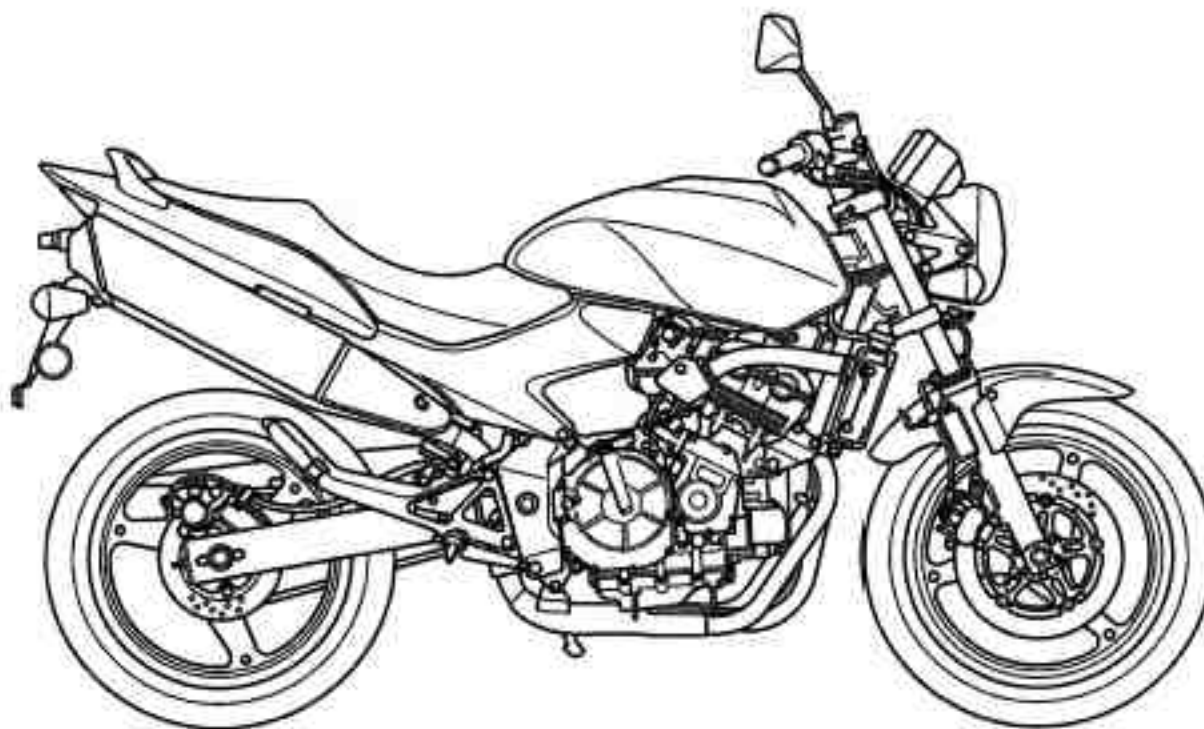

After '04 model:

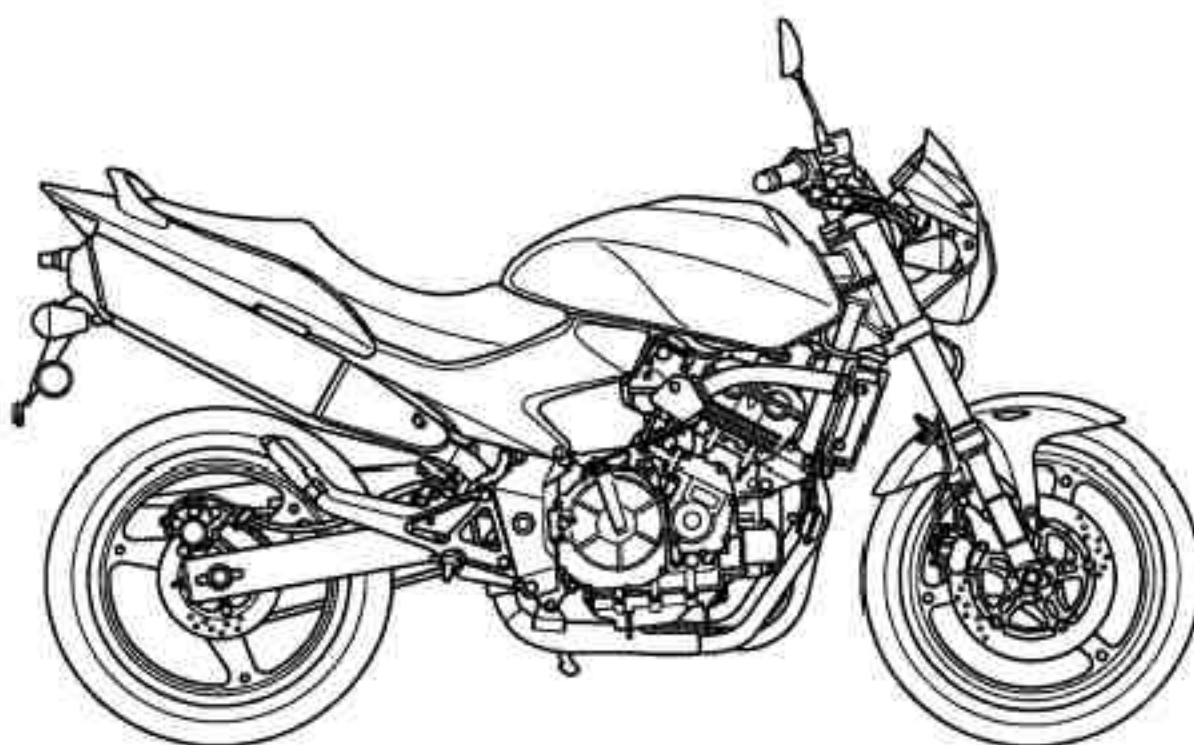

GENERAL INFORMATION

The frame serial number is stamped on the right side of the steering head.

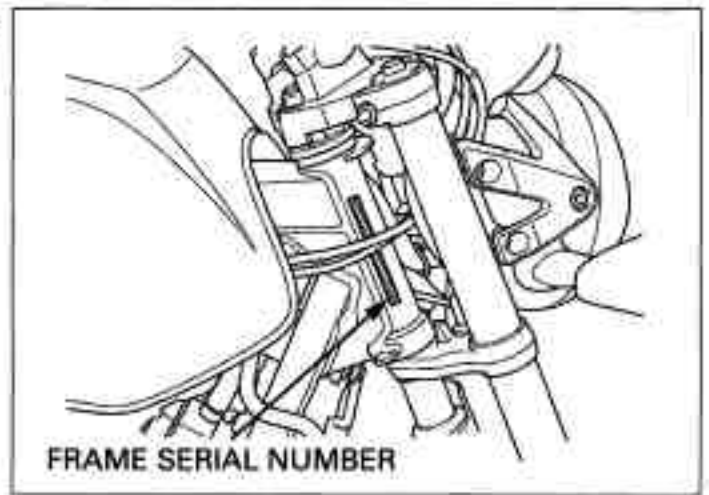

The engine serial number is stamped on the lower right side of the crankcase.

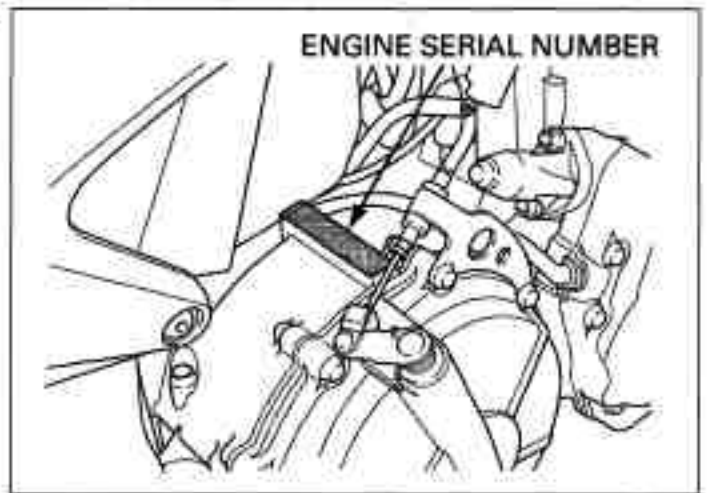

The carburetor identification number is stamped on the intake side of the carburetor body as shown.

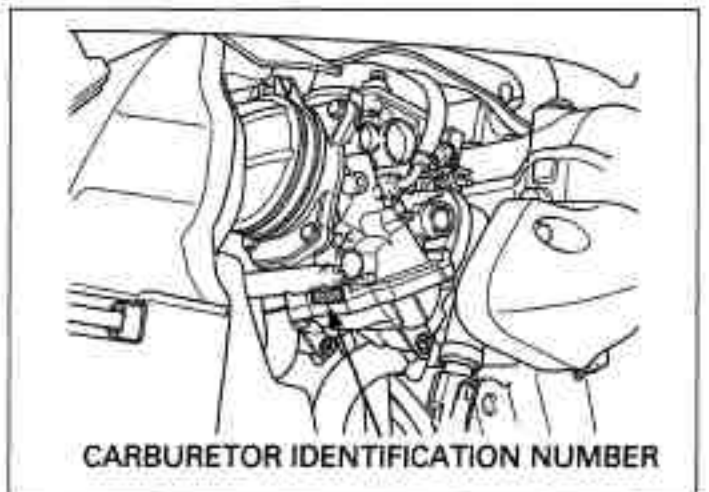

The vehicle Identification Number (VIN) is located on the left side of the steering head on the Safety Certification Label.

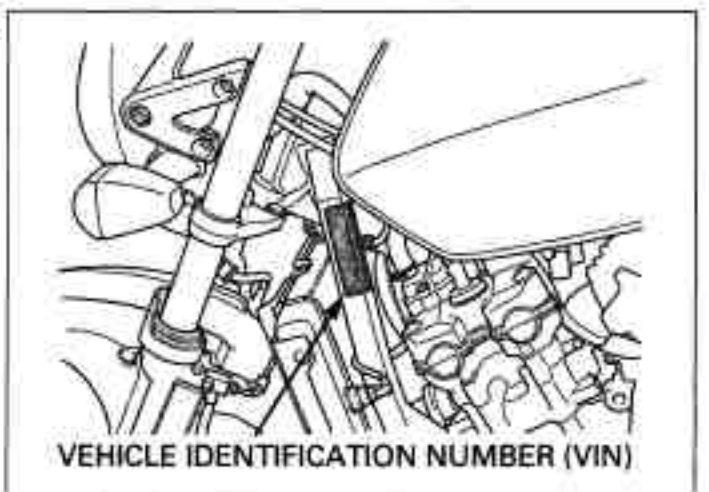

GENERAL INFORMATION

The color label is attached as shown. When ordering color-coded parts, always specify the designated color code.

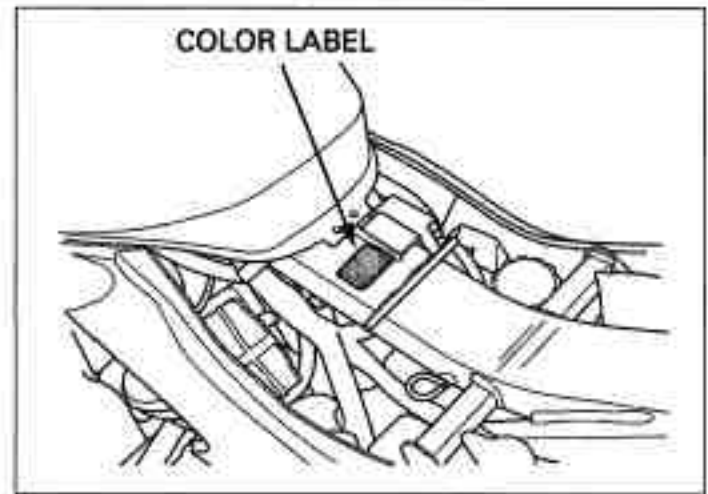

GENERAL INFORMATION

	ITEM	SPECIFICATIONS
DRIVE TRAIN	Clutch system Clutch operation system Transmission Primary reduction Final reduction Gear ratio 1st 2nd 3rd 4th 5th 6th Gearshift pattern	Multi-plate, wet Cable operating Constant mesh, 6-speeds 1.863 (82/44) 2.800 (42/15) 2.928 (41/14) 2.062 (33/16) 1.647 (28/17) 1.368 (26/19) 1.200 (24/20) 1.086 (25/23) Left foot operated return system, 1 - N - 2 - 3 - 4 - 5 - 6
ELECTRICAL	Ignition system Starting system Charging system Regulator/rectifier Lighting system	Full transistorized ignition Electric starter motor Triple phase output alternator SCR shorted/triple phase, full wave rectification Battery

LUBRICATION SYSTEM SPECIFICATIONS

Unit: mm (in)

ITEM		STANDARD	SERVICE LIMIT
Engine oil capacity	After draining	3.5 liter (3.7 US qt, 3.1 Imp qt)	-
	After draining/filter change	3.8 liter (4.0 US qt, 3.3 Imp qt)	-
	After disassembly	4.2 liter (4.4 US qt, 3.7 Imp qt)	-
Recommended engine oil		Pro Honda GN4 or HP4 (Without molybdenum additives) 4-stroke oil or equivalent motor oil API service classification SG or Higher JASO T 903 standard: MA Viscosity: SAE 10W-40	-
Oil pressure at oil pressure switch		490 kPa (5.0 kgf/cm ² , 71 psi) at 6,000 rpm/(80°C/176°F)	-
Oil pump rotor	Tip clearance	0.15 (0.006)	0.20 (0.008)
	Body clearance	0.15 – 0.22 (0.006 – 0.009)	0.35 (0.014)
	Side clearance	0.02 – 0.07 (0.001 – 0.003)	0.10 (0.004)
Oil pump drive sprocket collar O.D.		34.050 – 34.075 (1.3405 – 1.3415)	34.03 (1.340)
Oil pump drive sprocket I.D.		35.025 – 35.075 (1.3789 – 1.3809)	35.10 (1.382)

FUEL SYSTEM

ITEM		SPECIFICATIONS
Carburetor identification number ('04 model)	Except California type	VP49P
	California type	VP49Q
Carburetor identification number (After '04 model)	Except California type	VP49U
	California type	VP49T
Main jet		No.1/4; #108, No.2/3; #110
Slow jet		#40
Jet needle		B97A
Pilot screw	initial opening	See page 6-35
	high altitude adjustment	See page 6-36
Float level		13.7 mm (0.54 in)
Idle speed		1,400 ± 100 rpm
Throttle grip free play		2 – 6 mm (1/16 – 1/4 in)
Carburetor vacuum difference		Within 30 mm Hg (1.2 in Hg)
Base carburetor for synchronization		No.3 carburetor

COOLING SYSTEM SPECIFICATIONS

ITEM		SPECIFICATIONS
Coolant capacity	Radiator and engine	2.3 liter (2.43 US qt, 2.02 Imp qt)
	Reserve tank	0.30 liter (0.32 US qt, 0.26 Imp qt)
Radiator cap relief pressure		108 – 137 kPa (1.1 – 1.4 kgf/cm ² , 16 – 20 psi)
Thermostat	Begin to open	80 – 84 °C (176 – 183 °F)
	Fully open	95 °C (203 °F)
	Valve lift	8 mm (0.3 in) minimum
Recommended antifreeze		High quality ethylene glycol antifreeze containing corrosion protection inhibitors
Standard coolant concentration		1:1 mixture with soft water

GENERAL INFORMATION**CYLINDER HEAD/VALVES SPECIFICATIONS**

Unit: mm (in)

ITEM		STANDARD	SERVICE LIMIT
Cylinder compression		1,294 kPa (13.2 kgf/cm ² , 188 psi) at 350 rpm	
Valve clearance			
	IN	0.16 ± 0.03 (0.006 ± 0.001)	-
	EX	0.22 ± 0.03 (0.009 ± 0.001)	-
Camshaft	Cam lobe height	IN	36.220 – 36.300 (1.4260 – 1.4291)
		EX	35.380 – 35.460 (1.3929 – 1.3960)
	Journal O.D.		23.959 – 23.980 (0.9433 – 0.9411)
	Runout		-
	Oil clearance	0.020 – 0.062 (0.0008 – 0.0024)	0.10 (0.004)
Valve lifter	Valve lifter O.D.	25.978 – 25.993 (1.0228 – 1.0233)	25.97 (1.022)
	Valve lifter bore I.D.	26.010 – 26.026 (1.0240 – 1.0246)	26.04 (1.025)
Valve, valve guide	Valve stem O.D.	IN	3.975 – 3.990 (0.1565 – 0.1571)
		EX	3.965 – 3.980 (0.1561 – 0.1567)
	Valve guide I.D.	IN/EX	4.000 – 4.012 (0.1575 – 0.1580)
	Stem-to-guide clearance	IN	0.010 – 0.037 (0.0004 – 0.0015)
		EX	0.020 – 0.047 (0.0008 – 0.0019)
	Valve guide projection above cylinder head	IN	13.10 – 13.30 (0.516 – 0.524)
EX		11.30 – 11.50 (0.445 – 0.453)	
Valve seat width	IN/EX	0.90 – 1.10 (0.035 – 0.043)	
Valve spring free length	IN/EX	38.25 (1.506)	37.05 (1.46)
Cylinder head warpage		-	0.10 (0.004)

CLUTCH/GEARSHIFT LINKAGE SPECIFICATIONS

Unit: mm (in)

ITEM		STANDARD	SERVICE LIMIT
Clutch lever free play		10 – 20 (3/8 – 13/16)	-
Clutch	Spring free length	48.9 (1.93)	47.5 (1.87)
	Disc thickness	2.92 – 3.08 (0.115 – 0.121)	2.6 (0.10)
	Plate warpage	-	0.30 (0.012)
Clutch outer guide	I.D.	21.994 – 22.007 (0.8659 – 0.8664)	22.017 (0.8668)
	O.D.	34.975 – 34.991 (1.3770 – 1.3776)	34.965 (1.3766)
Mainshaft O.D. at clutch outer guide		21.980 – 21.993 (0.8654 – 0.8659)	21.95 (0.864)

ALTERNATOR/STARTER CLUTCH SPECIFICATIONS

Unit: mm (in)

ITEM	STANDARD	SERVICE LIMIT
Starter driven gear boss O.D.	51.699 – 51.718 (2.0354 – 2.0361)	51.684 (2.0348)

CRANKCASE/TRANSMISSION SPECIFICATIONS

Unit: mm (in)

ITEM		STANDARD	SERVICE LIMIT
Shift fork, fork shaft	I.D.	12.000 – 12.021 (0.4724 – 0.4733)	12.03 (0.474)
	Claw thickness	5.93 – 6.00 (0.233 – 0.236)	5.9 (0.23)
	Shift fork shaft O.D.	11.957 – 11.968 (0.4707 – 0.4712)	11.95 (0.470)
Transmission	Gear I.D.	M5, M6	28.000 – 28.021 (1.1024 – 1.1032)
		C2, C3, C4	31.000 – 31.025 (1.2205 – 1.2215)
	Gear busing O.D.	M5, M6	27.959 – 27.980 (1.1007 – 1.1016)
		C2, C3, C4	30.950 – 30.975 (1.2189 – 1.2197)
	Gear-to-bushing clearance	M5, M6	0.020 – 0.062 (0.0008 – 0.0024)
		C2, C3, C4	0.025 – 0.075 (0.0010 – 0.0030)
	Gear bushing I.D.	M5	24.985 – 25.006 (0.9837 – 0.9845)
		C2	27.985 – 28.006 (1.1018 – 1.1026)
	Mainshaft O.D.	at M5	24.967 – 24.980 (0.9830 – 0.9835)
	Countershaft O.D.	at C2	27.967 – 27.980 (1.1011 – 1.1016)
Bushing to shaft clearance	M5	0.005 – 0.039 (0.0002 – 0.0015)	
	C2	0.005 – 0.039 (0.0002 – 0.0015)	

CRANKSHAFT/PISTON/CYLINDER SPECIFICATIONS

Unit: mm (in)

ITEM		STANDARD	SERVICE LIMIT	
Crankshaft	Connecting rod side clearance	0.10 – 0.25 (0.004 – 0.010)	0.30 (0.012)	
	Crankpin bearing oil clearance	0.028 – 0.052 (0.0011 – 0.0020)	0.06 (0.002)	
	Main journal bearing oil clearance	0.020 – 0.045 (0.0008 – 0.0018)	0.05 (0.002)	
	Runout	-	0.05 (0.002)	
Piston, piston rings	Piston O.D. at 11 (0.4) from bottom	64.970 – 64.990 (2.5579 – 2.5587)	64.90 (2.555)	
	Piston pin bore I.D.	17.002 – 17.008 (0.6694 – 0.6696)	17.02 (0.670)	
	Piston pin O.D.	16.994 – 17.000 (0.6691 – 0.6693)	16.98 (0.669)	
	Piston -to piston pin clearance	0.002 – 0.014 (0.0001 – 0.0006)	0.04 (0.002)	
	Piston ring end gap	Top	0.10 – 0.20 (0.004 – 0.008)	0.4 (0.02)
		Second	0.18 – 0.30 (0.007 – 0.012)	0.5 (0.02)
		Oil (side rail)	0.20 – 0.70 (0.008 – 0.028)	1.0 (0.04)
Piston ring-to-ring groove clearance	Top	0.025 – 0.060 (0.0010 – 0.0024)	0.08 (0.003)	
	Second	0.015 – 0.050 (0.0006 – 0.0020)	0.08 (0.003)	
Cylinder	I.D.	65.000 – 65.015 (2.5591 – 2.5596)	65.10 (2.563)	
	Out of round	-	0.10 (0.004)	
	Taper	-	0.10 (0.004)	
	Warpage	-	0.10 (0.004)	
Cylinder-to piston clearance		0.010 – 0.045 (0.0004 – 0.0018)	0.10 (0.004)	
Connecting rod small end I.D.		17.016 – 17.034 (0.6699 – 0.6706)	17.04 (0.671)	
Connecting rod-to-piston pin clearance		0.016 – 0.040 (0.0006 – 0.0016)	0.06 (0.002)	

GENERAL INFORMATION**FRONT WHEEL/SUSPENSION/STEERING SPECIFICATIONS**

Unit: mm (in)

ITEM		STANDARD	SERVICE LIMIT
Minimum tire tread depth		-	1.5 (0.06)
Cold tire pressure	Driver only	250 kPa (2.50 kgf/cm ² , 36 psi)	-
	Driver and passenger	250 kPa (2.50 kgf/cm ² , 36 psi)	-
Axle runout		-	0.2 (0.01)
Wheel rim runout	Radial	-	2.0 (0.08)
	Axial	-	2.0 (0.08)
Wheel balance weight		-	60 g (2.1 oz) max.
Fork ('04 model)	Spring free length	338.3 (13.32)	331.5 (13.05)
	Pipe runout	-	0.20 (0.008)
	Recommended fork fluid	Pro Honda suspension fluid SS-8	-
	Fluid level	140 (5.5)	-
	Fluid capacity	447 ± 2.5 cm ³ (15.1 ± 0.08 US oz, 15.7 ± 0.09 Imp oz)	-
Fork (After '04 model)	Spring free length	281.6 (11.09)	276 (10.9)
	Pipe runout	-	0.20 (0.008)
	Recommended fork fluid	Pro Honda suspension fluid SS-8	-
	Fluid level	77 (3.3)	-
	Fluid capacity	483 ± 2.5 cm ³ (16.36 ± 0.08 US oz, 17.00 ± 0.09 Imp oz)	-
Steering head bearing pre-load		0.9 – 1.3 kgf (2.0 – 2.9 lbf)	-

REAR WHEEL/SUSPENSION SPECIFICATIONS

Unit: mm (in)

ITEM		STANDARD	SERVICE LIMIT
Minimum tire tread depth		-	2.0 (0.08)
Cold tire pressure	Driver only	290 kPa (2.90 kgf/cm ² , 42 psi)	-
	Driver and passenger	290 kPa (2.90 kgf/cm ² , 42 psi)	-
Axle runout		-	0.2 (0.01)
Wheel rim runout	Radial	-	2.0 (0.08)
	Axial	-	2.0 (0.08)
Wheel balance weight		-	60 g (2.1 oz) max.
Drive chain	Size/link	DID	525VM2-110LE
		RK	525RO-110LE
	Slack	30 – 40 (1.2 – 1.6)	50 (2.0)
Shock absorber pre-load adjuster standard position		2nd groove	-

HYDRAULIC BRAKE SPECIFICATIONS

Unit: mm (in)

ITEM		STANDARD	SERVICE LIMIT
Front	Specified brake fluid	DOT 4	-
	Brake disc thickness	4.5 (0.18)	3.5 (0.14)
	Brake disc runout	-	0.30 (0.012)
	Master cylinder I.D.	12.7 (0.50)	-
	Caliper cylinder I.D.	Upper	32.03 (1.261)
Lower		30.23 (1.190)	-
Rear	Specified brake fluid	DOT 4	-
	Brake pedal height	67.5 (2.66)	-
	Brake disk thickness	5.0 (0.20)	4.0 (0.16)
	Brake disc runout	-	0.30 (0.012)
	Master cylinder I.D.	14.00 (0.551)	-
	Caliper cylinder I.D.	33.96 (1.337)	-

BATTERY/CHARGING SYSTEM SPECIFICATIONS

ITEM		SPECIFICATIONS	
Battery	Capacity	12V - 6 Ah	
	Current leakage	1.2 mA max.	
	Voltage (20°C/68°F)	Fully charged	13.0 - 13.2 V
		Needs charging	Below 12.3 V
	Charging current	Normal	0.9 A/5 - 10 h
Quick		4.0 A/1.0 h	
Alternator	Capacity	0.34 kW/5,000 rpm	
	Charging coil resistance (20°C/68°F)	0.1 - 1.0 Ω	

IGNITION SYSTEM SPECIFICATIONS

ITEM		SPECIFICATIONS
Spark plug (Iridium)	NGK	CR9EH-9
	DENSO	W27FER9
Spark plug gap		0.80 - 0.90 mm (0.031 - 0.035 in)
Ignition coil peak voltage		100 V minimum
Ignition pulse generator peak voltage		0.7 V minimum
Ignition timing ("F" mark)		7° BTDC at idle

ELECTRIC STARTER SPECIFICATIONS

Unit: mm (in)

ITEM	STANDARD	SERVICE LIMIT
Starter motor brush length	12.0 - 13.0 (0.47 - 0.51)	4.5 (0.18)

GENERAL INFORMATION**LIGHTS/METERS/SWITCHES SPECIFICATIONS ('04 model)**

ITEM		SPECIFICATIONS	
Bulbs	Headlight	Hi	12V - 55 W
		Lo	12V - 55 W
	Position light		12V - 8 W X 2
	Brake/tail light		12V - 21/5 W X 2
	Turn signal light	Front	12V - 23 W X 2
		Rear	12V - 23 W X 2
	Instrument light		12V - 1.7 W X 2
	Turn signal indicator		12V - 1.7 W X 2
	High beam indicator		LED
	Neutral indicator		LED
	Oil pressure indicator		LED
Low fuel indicator		LED	
Fuse	Main fuse	30 A	
	Sub fuse	20 A X 1, 10 A X 4	
Tachometer peak voltage		10.5 V minimum	
Fan motor switch	Start to close (ON)	98 - 102 °C (208 - 216 °F)	
	Stop to open	93 - 97 °C (199 - 207 °F)	

LIGHTS/METERS/SWITCHES SPECIFICATIONS (After '04 model)

ITEM		SPECIFICATIONS	
Bulbs	Headlight	Hi	12V - 55 W
		Lo	12V - 55 W
	Position light		12V - 8 W X 2
	Brake/tail light		12V - 21/5 W X 2
	Turn signal light	Front	12V - 23 W X 2
		Rear	12V - 23 W X 2
	Instrument light		LED
	Turn signal indicator		LED
	High beam indicator		LED
	Neutral indicator		LED
	Oil pressure /Engine coolant temperature indicator		LED
Fuse	Main fuse	30 A	
	Sub fuse	20 A X 2, 10 A X 4	
Tachometer peak voltage		10.5 V minimum	
Fan motor switch	Start to close (ON)	98 - 102 °C (208 - 216 °F)	
	Stop to open	93 - 97 °C (199 - 207 °F)	

STANDARD TORQUE VALUES

FASTENER TYPE	TORQUE N-m (kgf-m, lbf-ft)	FASTENER TYPE	TORQUE N-m (kgf-m, lbf-ft)
5 mm hex bolt and nut	5 (0.5, 3.6)	5 mm screw	4 (0.4, 2.9)
6 mm hex bolt and nut	10 (1.0, 7)	6 mm screw	9 (0.9, 6.5)
8 mm hex bolt and nut	22 (2.2, 16)	6 mm flange bolt (8 mm head, small flange)	10 (1.0, 7)
10 mm hex bolt and nut	34 (3.5, 25)	6 mm flange bolt (8 mm head, large flange)	12 (1.2, 9)
12 mm hex bolt and nut	54 (5.5, 40)	6 mm flange bolt (10 mm head) and nut	12 (1.2, 9)
		8 mm flange bolt and nut	26 (2.7, 20)
		10 mm flange bolt and nut	39 (4.0, 29)

ENGINE & FRAME TORQUE VALUES

- Torque specifications listed below are for important fasteners.
- Others should be tightened to standard torque values listed above.

NOTE:

1. Apply sealant to the threads.
2. Apply a locking agent to the threads.
3. Stake.
4. Apply oil to the threads and flange surface.
5. U-nut.
6. ALOC bolt/screw: replace with a new one.
7. Apply grease to the threads.
8. Apply molybdenum disulfide oil to the threads and seating surface
9. CT bolt

ENGINE

MAINTENANCE

ITEM	Q'TY	THREAD DIA. (mm)	TORQUE N-m (kgf-m, lbf-ft)	REMARKS
Spark plug ('04 model)	4	10	12 (1.2, 9)	
Spark plug (After '04 model)	4	10	18 (1.8, 13)	
Timing hole cap	1	45	18 (1.8, 13)	NOTE 7
Engine oil filter cartridge	1	20	25 (2.5, 18)	NOTE 4
Engine oil drain bolt	1	12	29 (3.0, 22)	

LUBRICATION

ITEM	Q'TY	THREAD DIA. (mm)	TORQUE N-m (kgf-m, lbf-ft)	REMARKS
Oil filter boss	1	20	18 (1.8, 13)	NOTE 2
Oil pump driven sprocket bolt	1	6	15 (1.5, 11)	NOTE 2
Oil pump assembly bolt	1	6	7.8 (0.80, 5.8)	NOTE 9
Oil cooler sealing bolt	1	18	49 (5.0, 36)	NOTE 2

FUEL SYSTEM

ITEM	Q'TY	THREAD DIA. (mm)	TORQUE N-m (kgf-m, lbf-ft)	REMARKS
Insulator band screw	8	5	-	
Carburetor drain screw	4	4	1.5 (0.15, 1.1)	
Starting enrichment (SE) valve arm screw	2	4	1.8 (0.18, 1.3)	
Starting enrichment (SE) valve nut	4	10	1.8 (0.18, 1.3)	
Vacuum chamber cover screw	12	4	2.1 (0.21, 1.5)	
Air funnel holder screw	16	4	2.1 (0.21, 1.5)	
Float chamber screw	12	5	3.4 (0.35, 2.5)	
Throttle cable holder screw	2	5	3.4 (0.35, 2.5)	
Throttle position (TP) sensor bracket screw	1	5	3.4 (0.35, 2.5)	
Carburetor connecting nut, 5 mm	2	5	5.1 (0.52, 3.8)	
Carburetor connecting nut, 6 mm	2	6	10 (1.0, 7)	

GENERAL INFORMATION

COOLING SYSTEM

ITEM	Q'TY	THREAD DIA. (mm)	TORQUE N-m (kgf-m, lbf-ft)	REMARKS
Water pump cover bolt	2	6	13 (1.3, 9)	NOTE 9
ECT sensor	1	12	23 (2.3, 17)	
Water hose joint	1	12	29 (3.0, 22)	

ENGINE MOUNTING

ITEM	Q'TY	THREAD DIA. (mm)	TORQUE N-m (kgf-m, lbf-ft)	REMARKS
Drive sprocket special bolt	1	10	54 (5.5, 40)	

CYLINDER HEAD/VALVES

ITEM	Q'TY	THREAD DIA. (mm)	TORQUE N-m (kgf-m, lbf-ft)	REMARKS
Cylinder head sealing bolt	1	18	32 (3.3, 24)	NOTE 2
Cylinder head bolt	10	9	47 (4.8, 35)	NOTE 4
No.1 intake vacuum port plug ('04 model)	1	5	3 (0.3, 2.2)	
Cylinder head cover bolt	6	6	10 (1.0, 7)	
Camshaft holder flange bolt	20	6	12 (1.2, 9)	NOTE 4
Cam sprocket bolt	4	7	20 (2.0, 14)	NOTE 2
Cam chain tensioner cap nut	1	6	12 (1.2, 9)	
Cam chain lifter sealing bolt	1	6	10 (1.0, 7)	
Reed valve cover bolt	4	6	13 (1.3, 9)	NOTE 9

CLUTCH/GEARSHIFT LINKAGE

ITEM	Q'TY	THREAD DIA. (mm)	TORQUE N-m (kgf-m, lbf-ft)	REMARKS
Clutch center lock nut	1	20	108 (11.0, 80)	NOTE 3, 4
Clutch spring bolt	4	6	12 (1.2, 9)	
Shift drum center socket bolt	1	8	23 (2.3, 17)	NOTE 2
Shift drum stopper arm pivot bolt	1	6	12 (1.2, 9)	
Gearshift return spring pin	1	8	23 (2.3, 17)	

ALTERNATOR/STARTER CLUTCH

ITEM	Q'TY	THREAD DIA. (mm)	TORQUE N-m (kgf-m, lbf-ft)	REMARKS
Flywheel flange bolt	1	10	103 (10.5, 76)	NOTE 4
Stator mounting socket bolt	4	6	12 (1.2, 9)	
Alternator wire clamp socket bolt	1	6	10 (1.0, 7)	
Starter clutch outer torx bolt	6	6	16 (1.6, 12)	NOTE 2

CRANKCASE/TRANSMISSION

ITEM	Q'TY	THREAD DIA. (mm)	TORQUE N-m (kgf-m, lbf-ft)	REMARKS
Main journal bolt	10	8	26 (2.7, 20)	NOTE 4
Crank case bolt, 10 mm	1	10	39 (4.0, 29)	
Crankcase bolt, 8 mm	1	8	24 (2.4, 17)	
Lower crankcase sealing bolt, 20 mm	1	20	30 (3.1, 22)	NOTE 2
Lower crankcase sealing bolt, 14 mm	1	14	25 (2.5, 18)	NOTE 2

GENERAL INFORMATION**CRANKSHAFT/PISTON/CYLINDER**

ITEM	Q'TY	THREAD DIA. (mm)	TORQUE N·m (kgf·m, lbf·ft)	REMARKS
Connecting rod bearing cap nut	8	7	25 (2.6, 19)	NOTE 4

IGNITION SYSTEM

ITEM	Q'TY	THREAD DIA. (mm)	TORQUE N·m (kgf·m, lbf·ft)	REMARKS
Ignition pulse generator rotor special bolt	1	10	59 (6.0, 43)	

ELECTRIC STARTER

ITEM	Q'TY	THREAD DIA. (mm)	TORQUE N·m (kgf·m, lbf·ft)	REMARKS
Starter motor terminal nut	1	6	10 (1.0, 7)	

LIGHTS/METERS/SWITCHES

ITEM	Q'TY	THREAD DIA. (mm)	TORQUE N·m (kgf·m, lbf·ft)	REMARKS
Oil pressure switch	1	PT 1/8	12 (1.2, 9)	NOTE 1
Oil pressure switch terminal screw	1	4	2.0 (0.20, 1.4)	
Neutral switch	1	10	12 (1.2, 9)	

GENERAL INFORMATION

Insulator clamp (carburetor side):

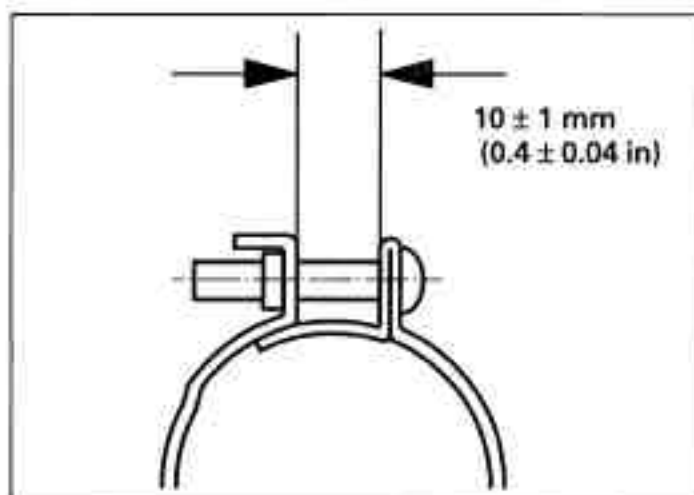

Insulator clamp (Cylinder head side):

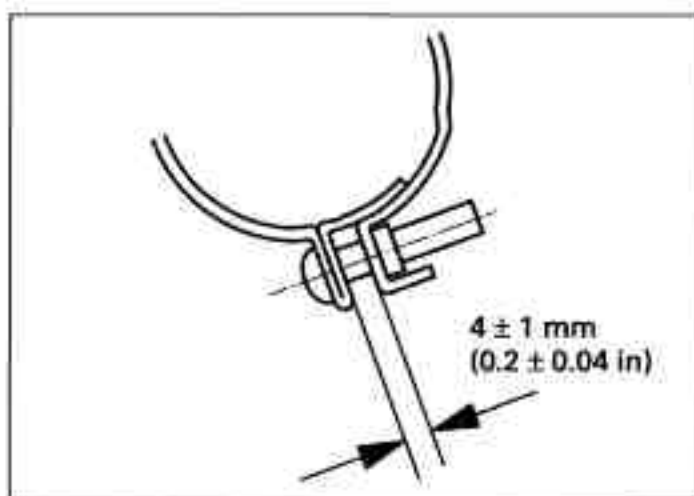

Exhaust pipe stud bolt:

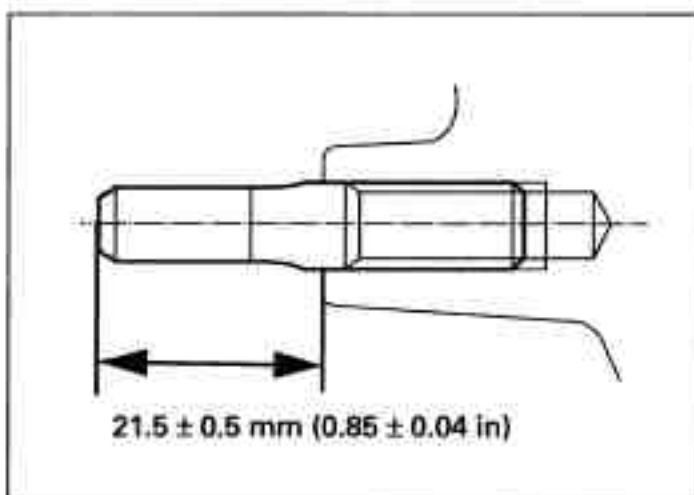

FRAME

FRAME BODY PANELS/EXHAUST SYSTEM

ITEM	Q'TY	THREAD DIA. (mm)	TORQUE N-m (kgf-m, lbf-ft)	REMARKS
Footpeg holder bolt	4	8	26 (2.7, 20)	
Exhaust pipe joint nut	6	7	20 (2.0, 14)	
Exhaust pipe mounting nut	1	8	22 (2.2, 16)	
Muffler mounting bolt	1	8	22 (2.2, 16)	
Muffler band bolt	1	8	22 (2.2, 16)	
Grab rail mounting socket bolt	4	8	26 (2.7, 20)	
Front fender mounting bolt	2	6	12 (1.2, 9)	
Rearview mirror mounting nut	2	10	3.4 (0.35, 2.5)	
Rear turn signal unit mounting nut	2	10	4.9 (0.50, 3.6)	
Taillight mounting nut	2	6	6.9 (0.70, 5.1)	
Side cover socket bolt	2	5	4 (0.4, 3)	

FUEL SYSTEM

ITEM	Q'TY	THREAD DIA. (mm)	TORQUE N-m (kgf-m, lbf-ft)	REMARKS
Fuel valve nut	1	22	34 (3.5, 25)	
Fuel tank stay nut	2	6	12 (1.2, 9)	

COOLING SYSTEM

ITEM	Q'TY	THREAD DIA. (mm)	TORQUE N-m (kgf-m, lbf-ft)	REMARKS
Fan motor switch	1	16	18 (1.8, 13)	NOTE 1
Cooling fan nut	1	5	2.7 (0.28, 2.0)	NOTE 2
Fan motor mounting nut	3	5	5.1 (0.52, 3.8)	

ENGINE MOUNTING

ITEM	Q'TY	THREAD DIA. (mm)	TORQUE N-m (kgf-m, lbf-ft)	REMARKS
Front engine hanger nut	2	10	54 (5.5, 40)	
Engine hanger bracket bolt	2	8	22 (2.2, 16)	
Rear engine hanger nut (upper)	1	10	54 (5.5, 40)	
Rear engine hanger nut (lower)	1	10	54 (5.5, 40)	

CLUTCH/GEARSHIFT LINKAGE

ITEM	Q'TY	THREAD DIA. (mm)	TORQUE N-m (kgf-m, lbf-ft)	REMARKS
Gearshift pedal link bolt (gearshift pedal side)	1	8	26 (2.7, 20)	
Gearshift pedal link bolt (gearshift spindle side)	1	6	20 (2.0, 14)	

FRONT WHEEL/SUSPENSION/STEERING

ITEM	Q'TY	THREAD DIA. (mm)	TORQUE N-m (kgf-m, lbf-ft)	REMARKS
Handlebar holder bolt	4	8	26 (2.7, 20)	
Steering stem nut	1	24	103 (10.5, 76)	
Steering bearing adjustment nut lock nut	1	26	-	
Steering bearing adjustment nut	1	26	-	
Fork top bridge pinch bolt	2	8	23 (2.3, 17)	
Fork bottom bridge pinch bolt	2	10	39 (4.0, 29)	
Front axle bolt	1	14	59 (6.0, 43)	
Front axle holder bolt	2	8	22 (2.2, 16)	
Front brake disc mounting bolt	12	6	20 (2.0, 14)	NOTE 6
Fork cap ('04 model)	2	37	23 (2.3, 17)	
Front fork bolt (After '04 model)	2	37	34 (3.5, 25.1)	
Fork socket bolt	2	8	20 (2.0, 14)	NOTE 2

GENERAL INFORMATION

REAR WHEEL/SUSPENSION

ITEM	Q'TY	THREAD DIA. (mm)	TORQUE N-m (kgf-m, lbf-ft)	REMARKS
Rear axle nut	1	16	88 (9.0, 65)	NOTE 5
Rear brake disc mounting bolt	4	8	42 (4.3, 31)	NOTE 6
Final driven sprocket nut	5	12	108 (11.0, 80)	NOTE 5
Swingarm pivot nut	1	14	88 (9.0, 65)	NOTE 5
Drive chain case bolt	2	6	12 (1.2, 9)	
Drive chain slider bolt	2	6	8.8 (0.90, 6.5)	
Drive chain adjuster lock nut	2	8	21 (2.1, 15)	
Rear shock absorber upper mounting nut	1	10	37 (3.8, 27)	NOTE 5
Rear shock absorber lower mounting nut	1	10	37 (3.8, 27)	NOTE 5

HYDRAULIC BRAKE

ITEM	Q'TY	THREAD DIA. (mm)	TORQUE N-m (kgf-m, lbf-ft)	REMARKS
Front brake master cylinder holder bolt	2	6	12 (1.2, 9)	
Front brake master cylinder reservoir cap screw	2	4	1.5 (0.15, 1.1)	
Brake lever pivot bolt	1	6	0.9 (0.10, 0.7)	
Brake lever pivot nut	1	6	5.9 (0.60, 4.3)	
Front brake light switch screw	1	4	1.2 (0.12, 0.9)	
Front brake caliper mounting bolt	4	8	30 (3.1, 22)	NOTE 6
Front brake caliper pin bolt A	1	12	23 (2.3, 17)	NOTE 2
Front brake caliper pin bolt	1	8	13 (1.3, 9)	NOTE 2
Pad pin	3	10	18 (1.8, 13)	
Pad pin plug	3	10	2.5 (0.25, 1.8)	
Front brake hose clamp bolt ('04 model)	2	6	12 (1.2, 9)	NOTE 6
Front brake hose clamp cap nut (After '04 model)	2	6	12 (1.2, 9)	NOTE 6
Brake caliper bleeder	3	8	5.4 (0.55, 4)	
Rear master cylinder mounting bolt	2	6	12 (1.2, 9)	
Rear master cylinder hose joint screw	1	4	1.5 (0.15, 1.1)	NOTE 2
Rear master cylinder push rod nut	1	8	18 (1.8, 13)	
Rear brake caliper main slide pin	1	12	27 (2.8, 20)	
Rear brake caliper sub slide pin	1	8	23 (2.3, 17)	NOTE 6
Rear brake hose clamp bolt	1	6	8.8 (0.90, 6.5)	NOTE 6
Brake hose oil bolt	5	10	34 (3.5, 25)	

LIGHTS/METERS/SWITCHES

ITEM	Q'TY	THREAD DIA. (mm)	TORQUE N-m (kgf-m, lbf-ft)	REMARKS
Ignition switch mounting bolt	1	6	25 (2.5, 18)	
Licence light screw	2	4	1.7 (0.17, 1.2)	
Tail light screw	2	5	1.7 (0.17, 1.2)	



OTHERS

ITEM	Q'TY	THREAD DIA. (mm)	TORQUE N-m (kgf-m, lbf-ft)	REMARKS
Side stand pivot bolt	1	10	15 (1.5, 11)	
Side stand pivot lock nut	1	10	39 (4.0, 29)	

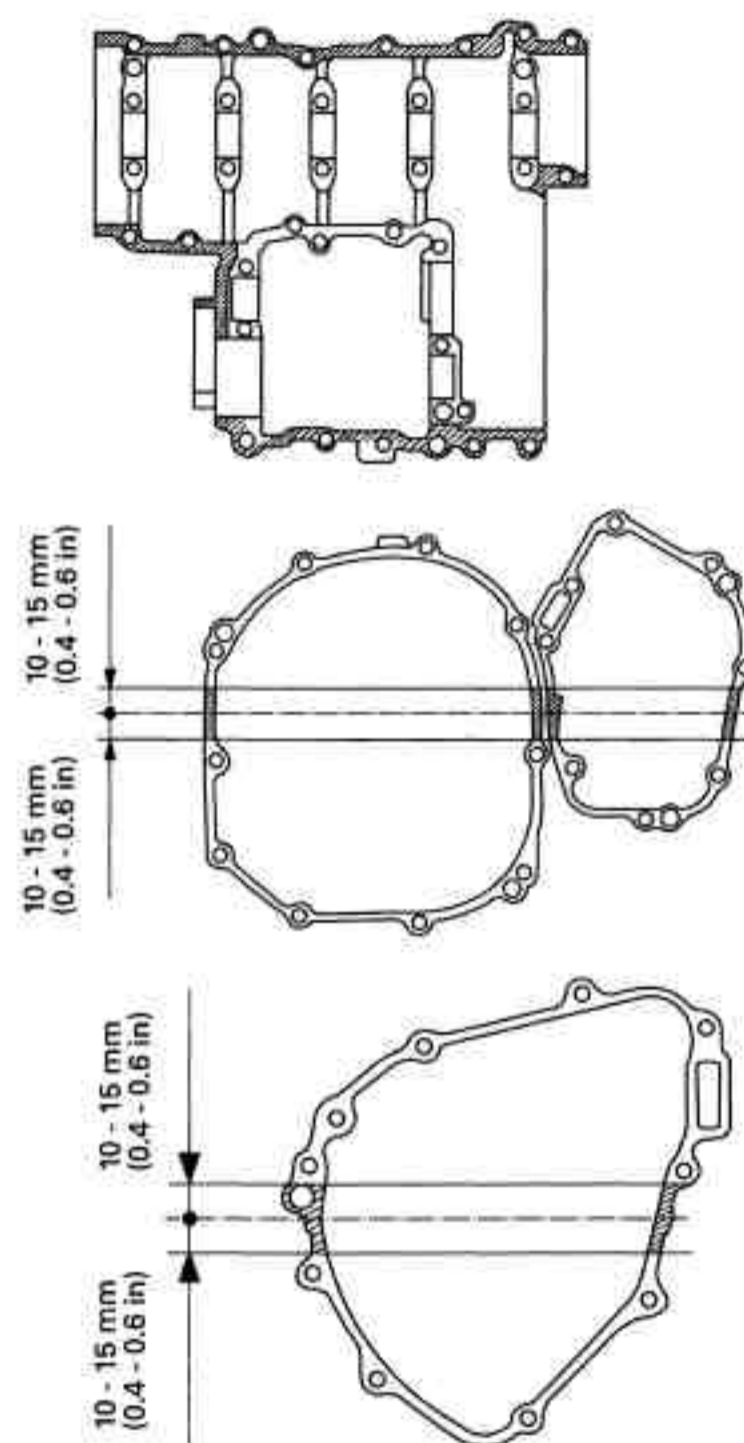
LUBRICATION & SEAL POINTS
ENGINE

LOCATION	MATERIAL	REMARKS
<p>Crankcase mating surface</p>  <p>Oil pan mating surface</p>	<p>Liquid sealant (Three Bond 1207B or equivalent)</p>	

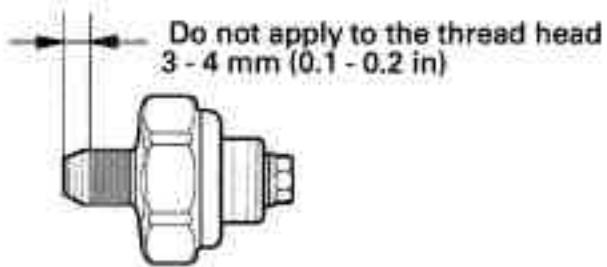
GENERAL INFORMATION

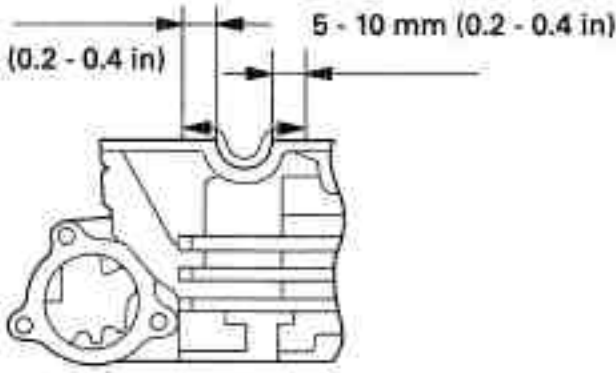
LOCATION	MATERIAL	REMARKS
<p>Oil pressure switch threads</p>  <p>Do not apply to the thread head 3 - 4 mm (0.1 - 0.2 in)</p> <p>Ignition pulse generator cover bolt threads</p> <p>2 PLACES</p>  <p>Ignition pulse generator cover grommet ECT sensor threads Lower crankcase sealing bolt threads Cylinder head sealing bolt threads Alternator cover grommet Cylinder head semi-circular cut-out</p>  <p>5 - 10 mm (0.2 - 0.4 in)</p>	<p>Sealant</p>	<p>Crankcase mating surface</p> <p>Crankcase mating surface</p>
<p>Cylinder head bolt threads and seating surface</p> <p>Camshaft lobes/journals Valve lifter outer sliding surface Valve stem (valve guide sliding surface) Connecting rod small end bore Main journal bearing surface Connecting rod bearing surface M3/4, C5, C6 shifter gear (shift fork grooves) Crankshaft thrust surface Clutch outer sliding surface Starter idle gear shaft sliding surface</p>	<p>Molybdenum disulfide oil (a mixture of 1/2 engine oil and 1/2 molybdenum disulfide grease)</p>	<p>Clean anti-rust oil and apply to the threads and seating surface</p>

GENERAL INFORMATION

LOCATION	MATERIAL	REMARKS
Clutch center lock nut threads Main journal 8 mm bolt threads and seating surface Connecting rod bolt/nut threads Camshaft holder bolt threads and seating surface Flywheel bolt threads Oil filter cartridge threads and mating surface Starter clutch sliding surface Piston surface Piston pin bore Piston ring grooves Piston pin surface Piston ring surface Cam chain tensioner collar sliding surface Cam chain tensioner and slipper surface Clutch friction disc lining surface Oil seal lip (without dust lip) Each gear teeth and rotating surface Each bearing Each O-ring Other rotating area and sliding surface	Engine oil	
Timing hole cap threads Each oil seal lips (without dust lip)	Multi-purpose grease	
Cylinder head cover breather plate bolt threads Cam sprocket bolt threads Oil pump driven sprocket bolt threads Shift drum bearing set plate bolt threads Starter clutch outer torx bolt threads Shift drum center bolt threads Mainshaft bearing set plate bolt threads Gearshift spindle oil seal set plate bolt threads Oil filter boss threads Oil cooler sealing bolt threads	Locking agent	Coating width: 6.5 ± 1 mm Coating width: 6.5 ± 1 mm Coating width: 6.5 ± 1 mm Coating width: 6.5 ± 1 mm Coating width: 6.5 ± 1 mm Coating width: 6.5 ± 1 mm Coating width: 6.5 ± 1 mm Coating width: 6.5 ± 1 mm

GENERAL INFORMATION

FRAME

LOCATION	MATERIAL	REMARKS
Seat catch hook sliding area Steering head bearing sliding surface Steering head dust seal lips Swingarm pivot needle bearing Rear wheel sleeve sliding surface Rear wheel hub O-ring Side stand pivot sliding surface Clutch lever pivot sliding surface Throttle pipe sliding area and cable end Footpeg pivot sliding area Gearshift pedal link sliding area Swingarm dust seal lips Rear brake pedal sliding surface Each oil seal lips Each dust seal lips	Multi-purpose grease	
Steering bearing adjustment nut threads	Engine oil	
Drive chain	#80 - 90 gear oil	
Brake master piston and cups Brake caliper piston and piston seals	DOT 4 brake fluid	
Front brake lever pivot and piston tips Rear master cylinder boot inside and push rod tips Brake caliper slide pin surface Brake caliper dust seals	Silicone grease	
Brake lever adjuster stopper bolt threads Fork socket bolt threads Rear brake caliper bracket retainer joint with bracket Front brake caliper pin bolt A threads Front brake caliper pin bolt threads	Locking agent	
Fan motor switch threads and O-ring	Sealant	
Handlebar grip rubber inside	Honda bond A or equivalent	
Fork oil seal lips	Pro Honda suspension fluid SS-8	

CABLE & HARNESS ROUTING

'04 model:

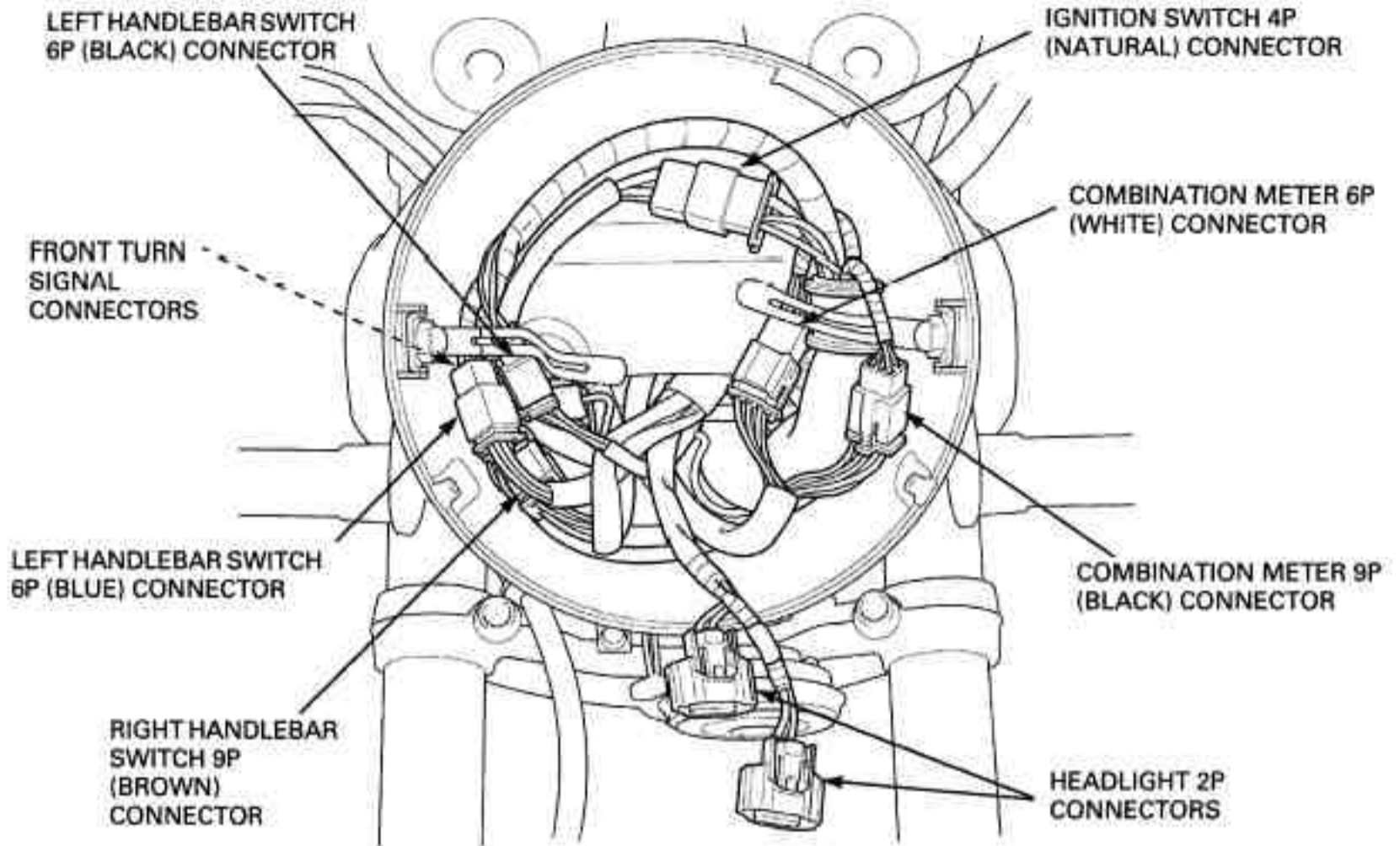

After '04 model:

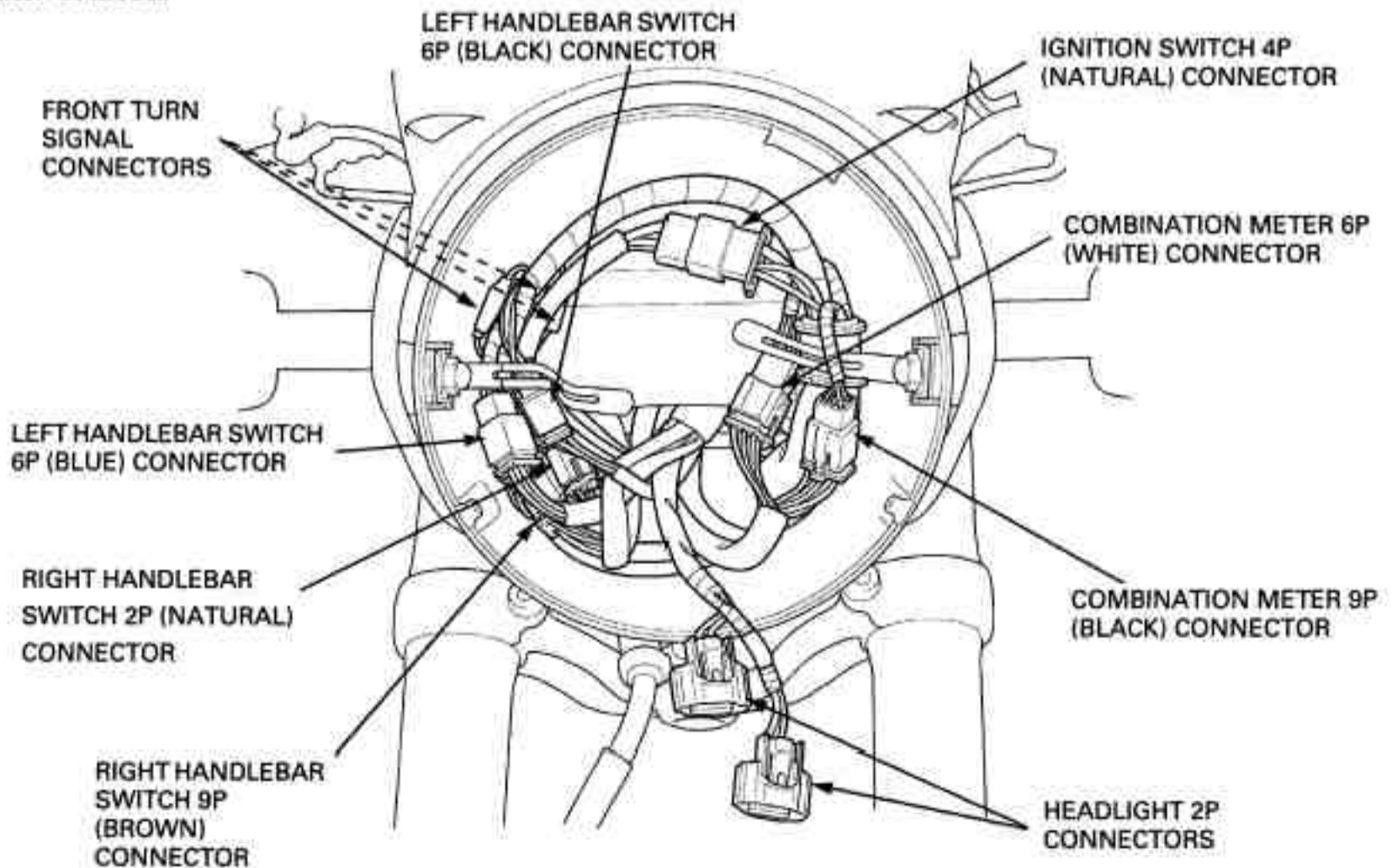

GENERAL INFORMATION

'04 model:

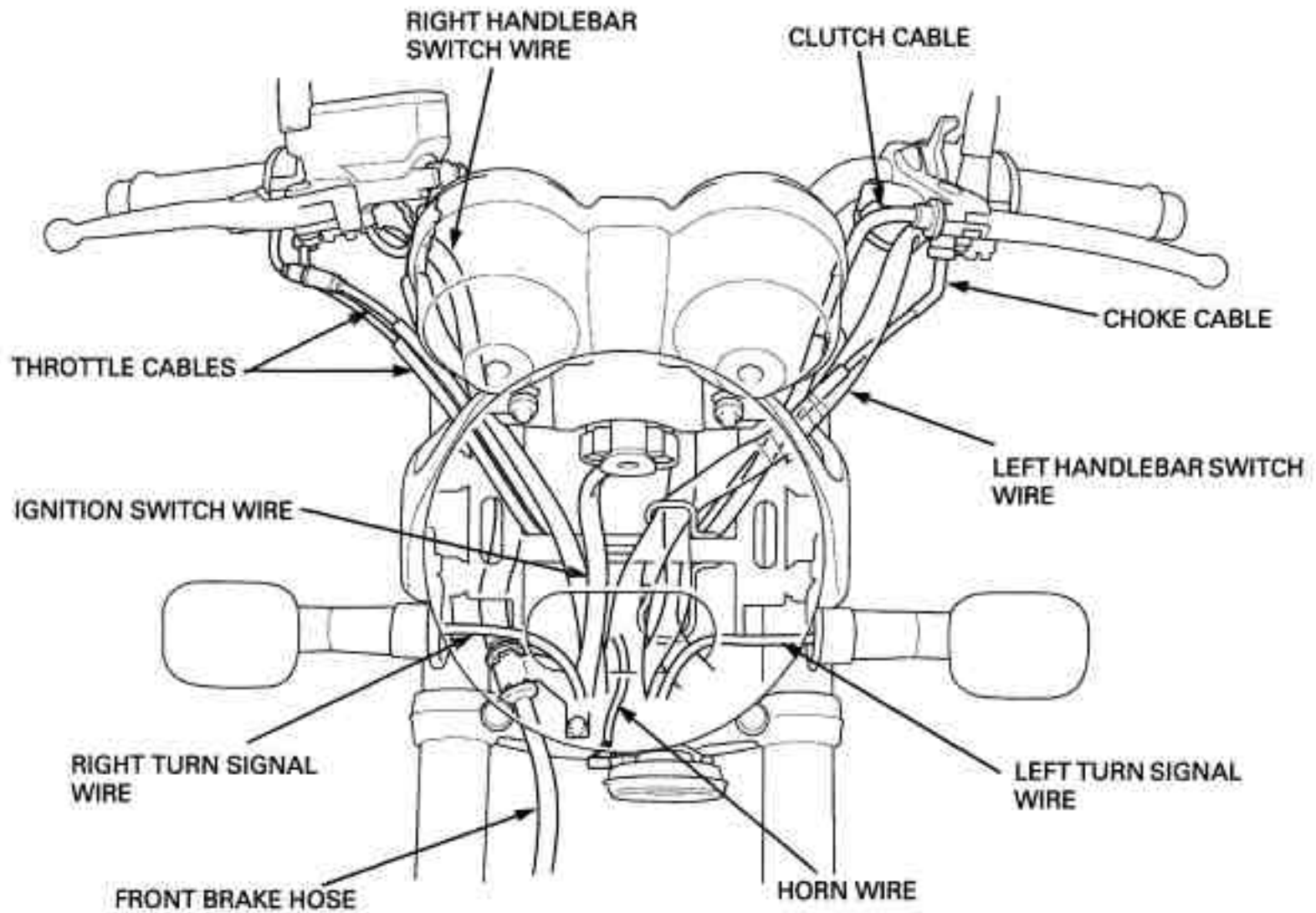

After '04 model:

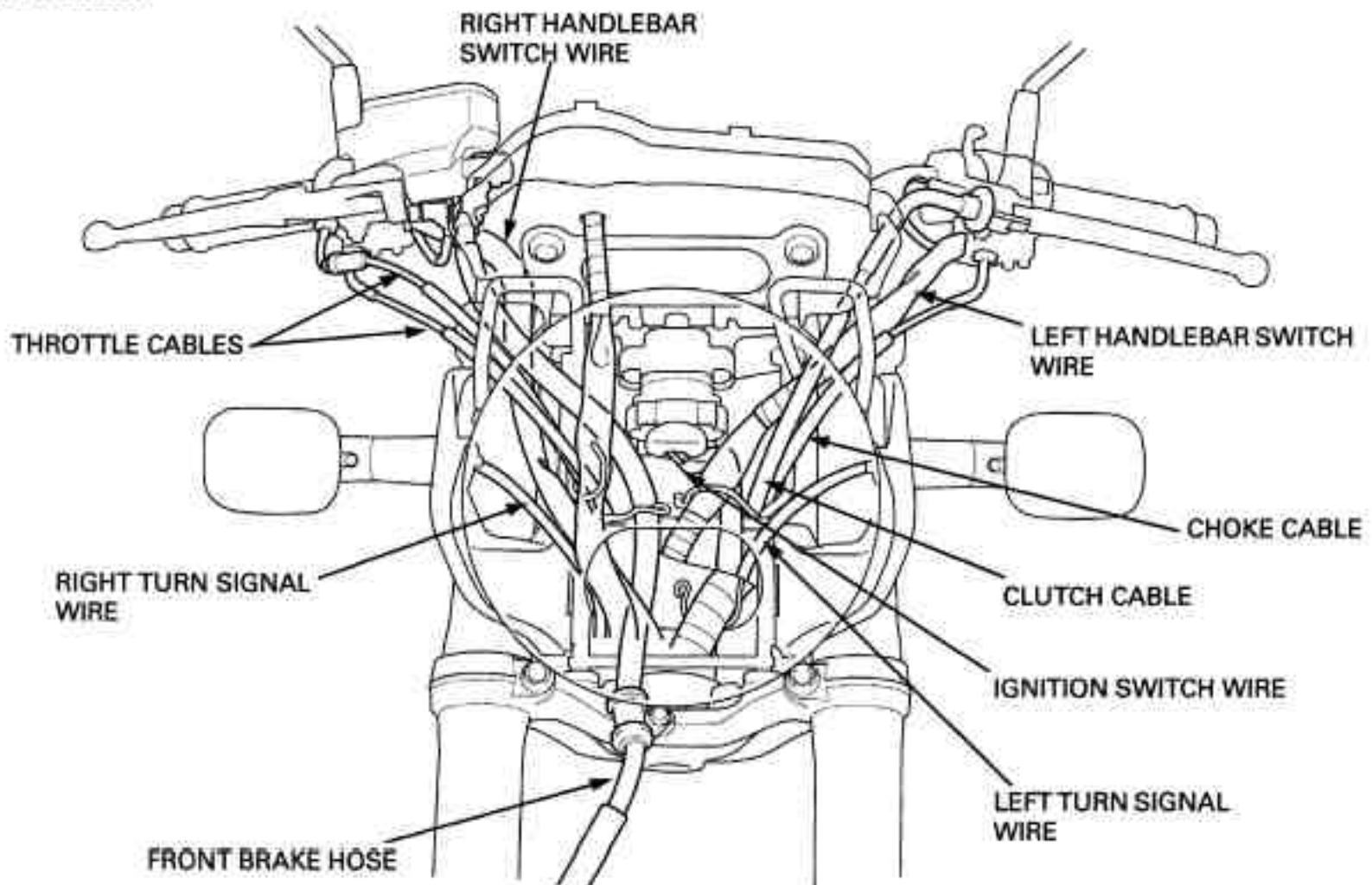

'04 model:

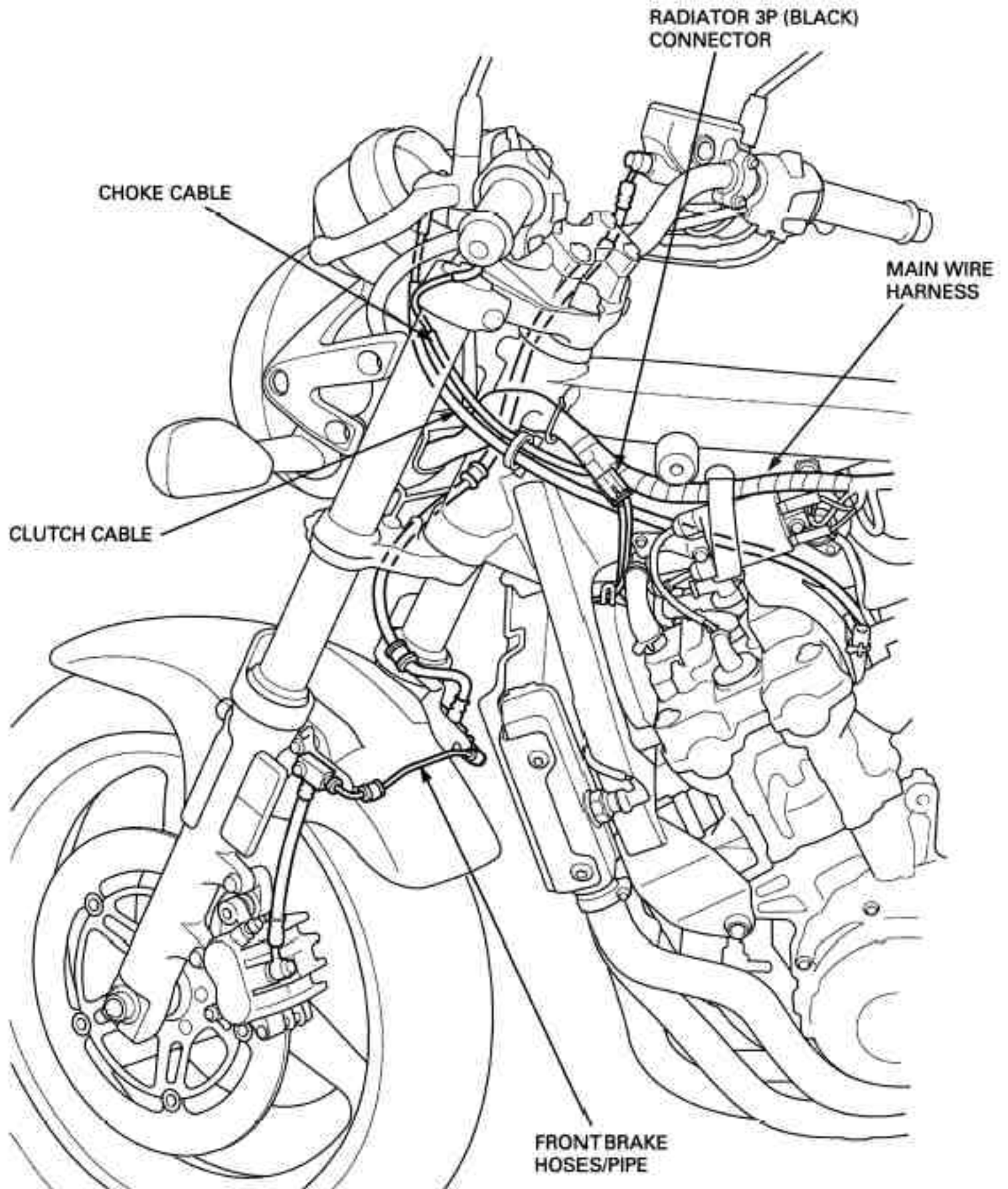

GENERAL INFORMATION

After '04 model:

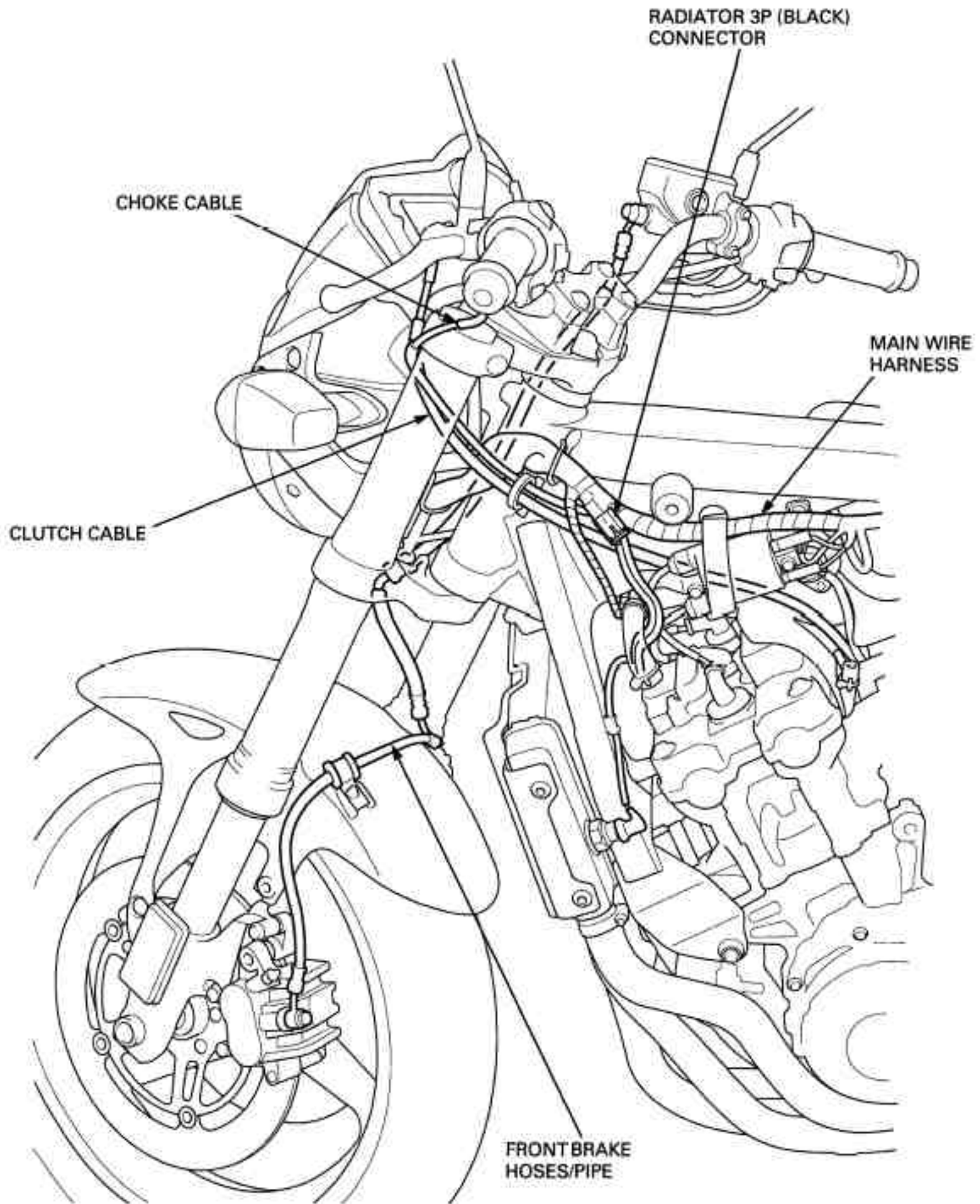

'04 model:

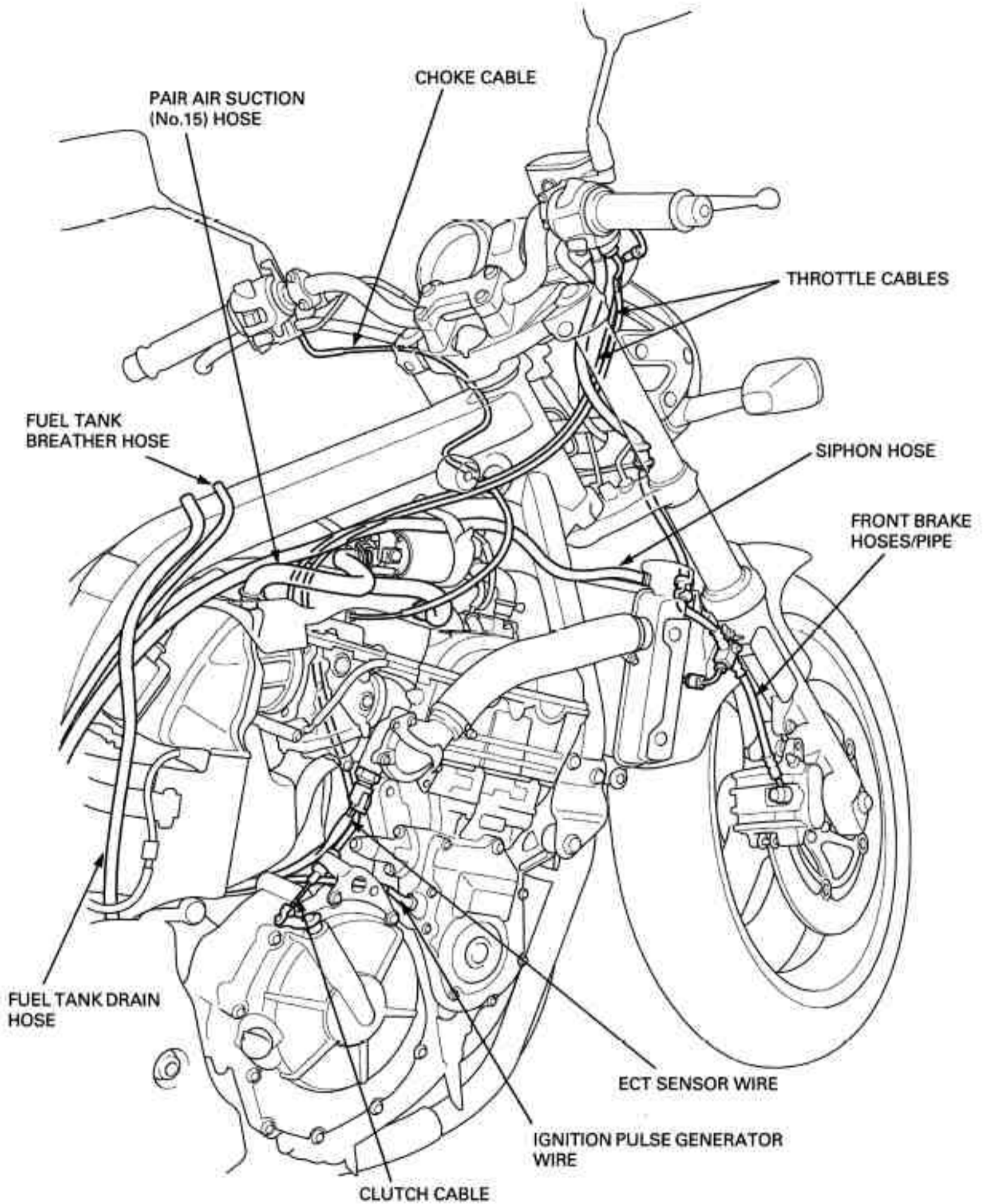

GENERAL INFORMATION

After '04 model:

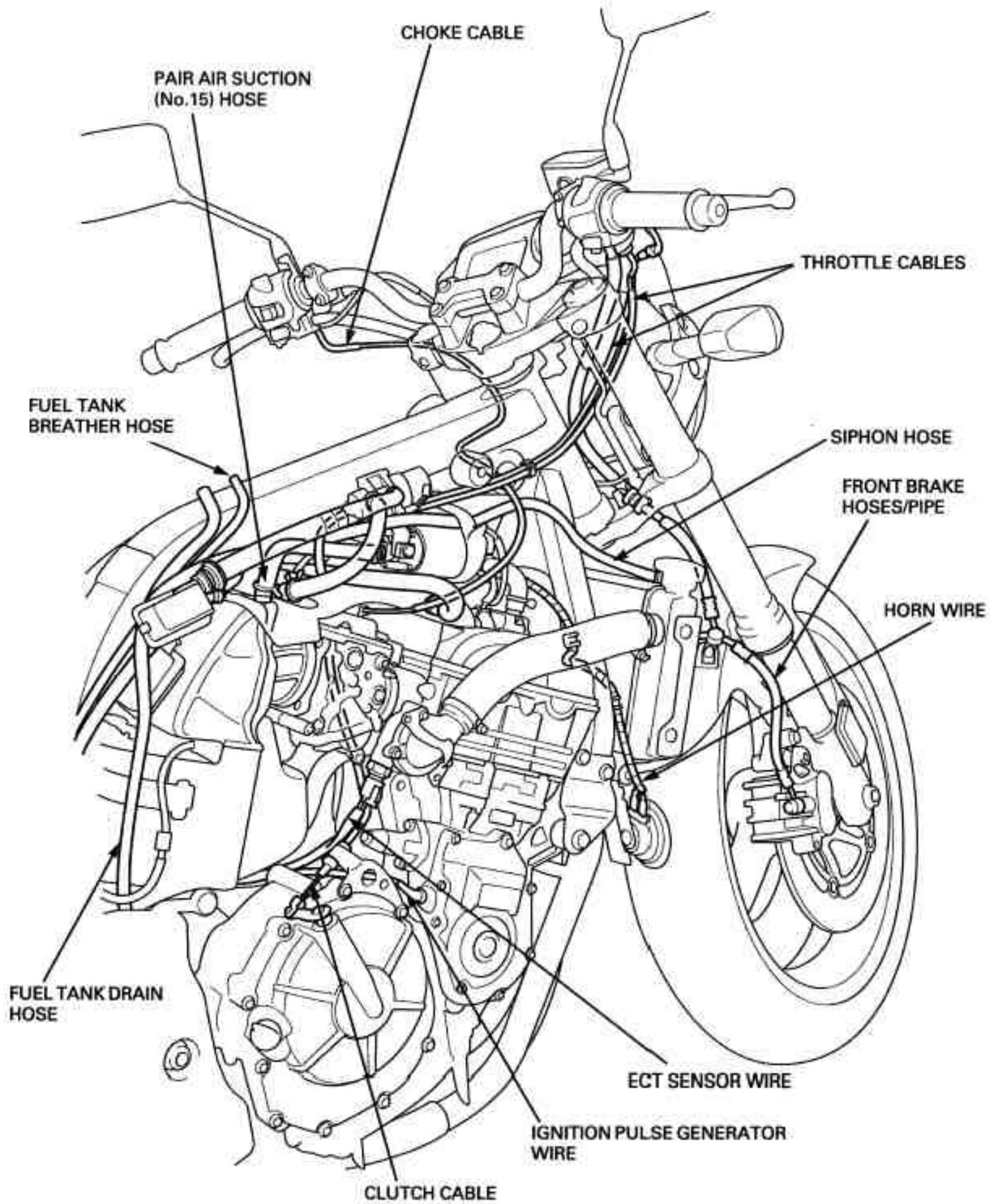

'04 model:

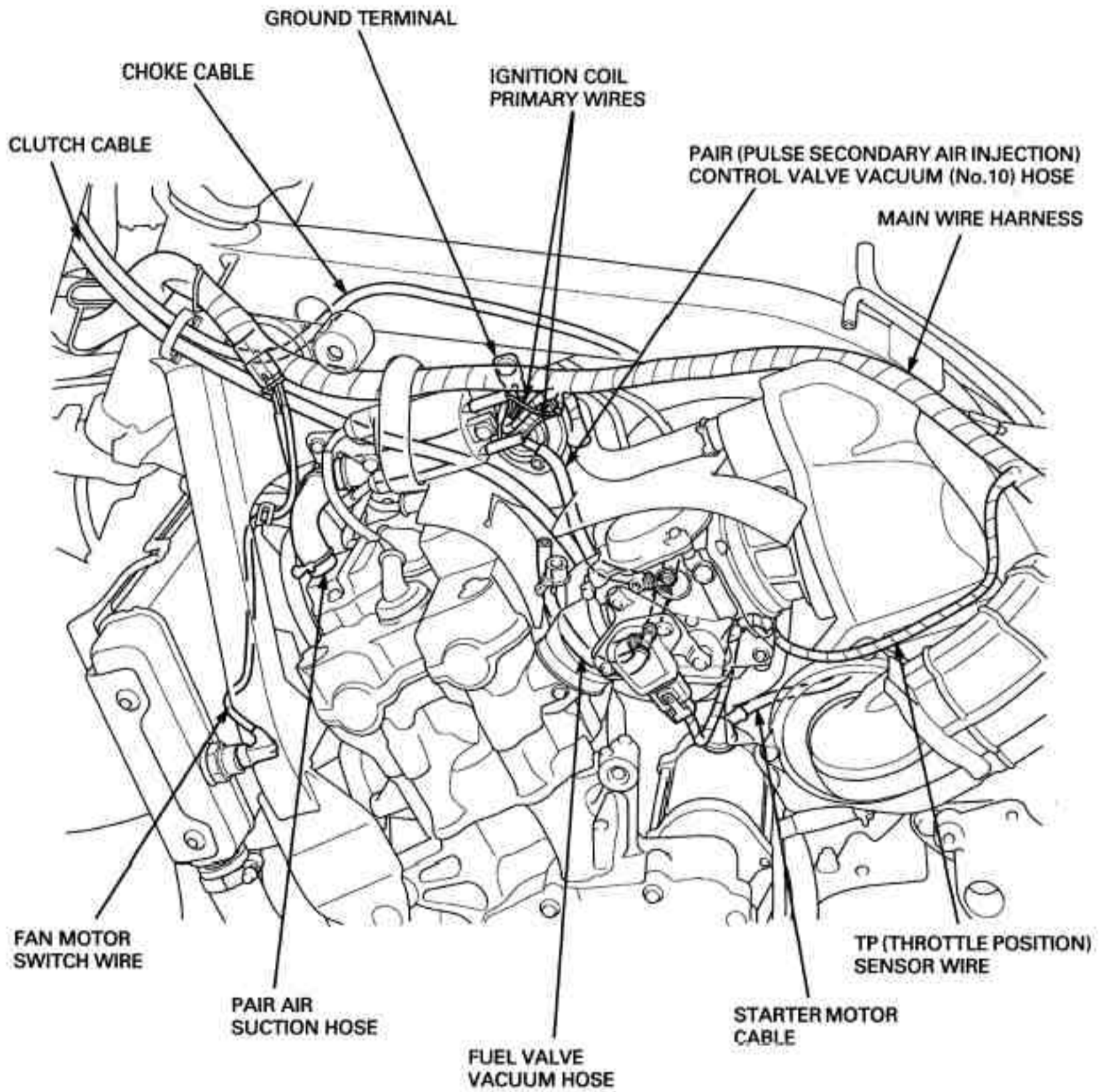

GENERAL INFORMATION

After '04 model:

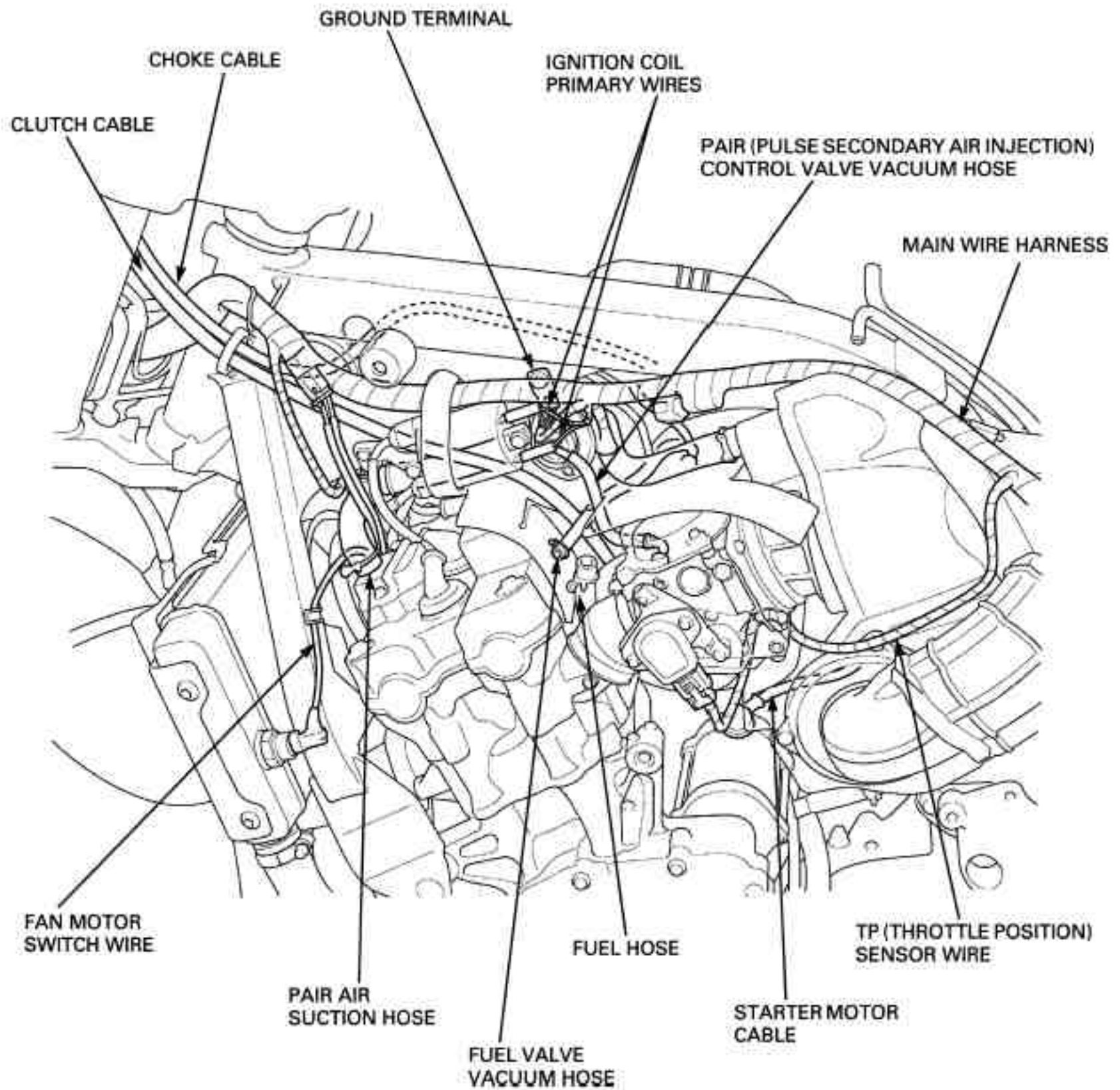

'04 model:

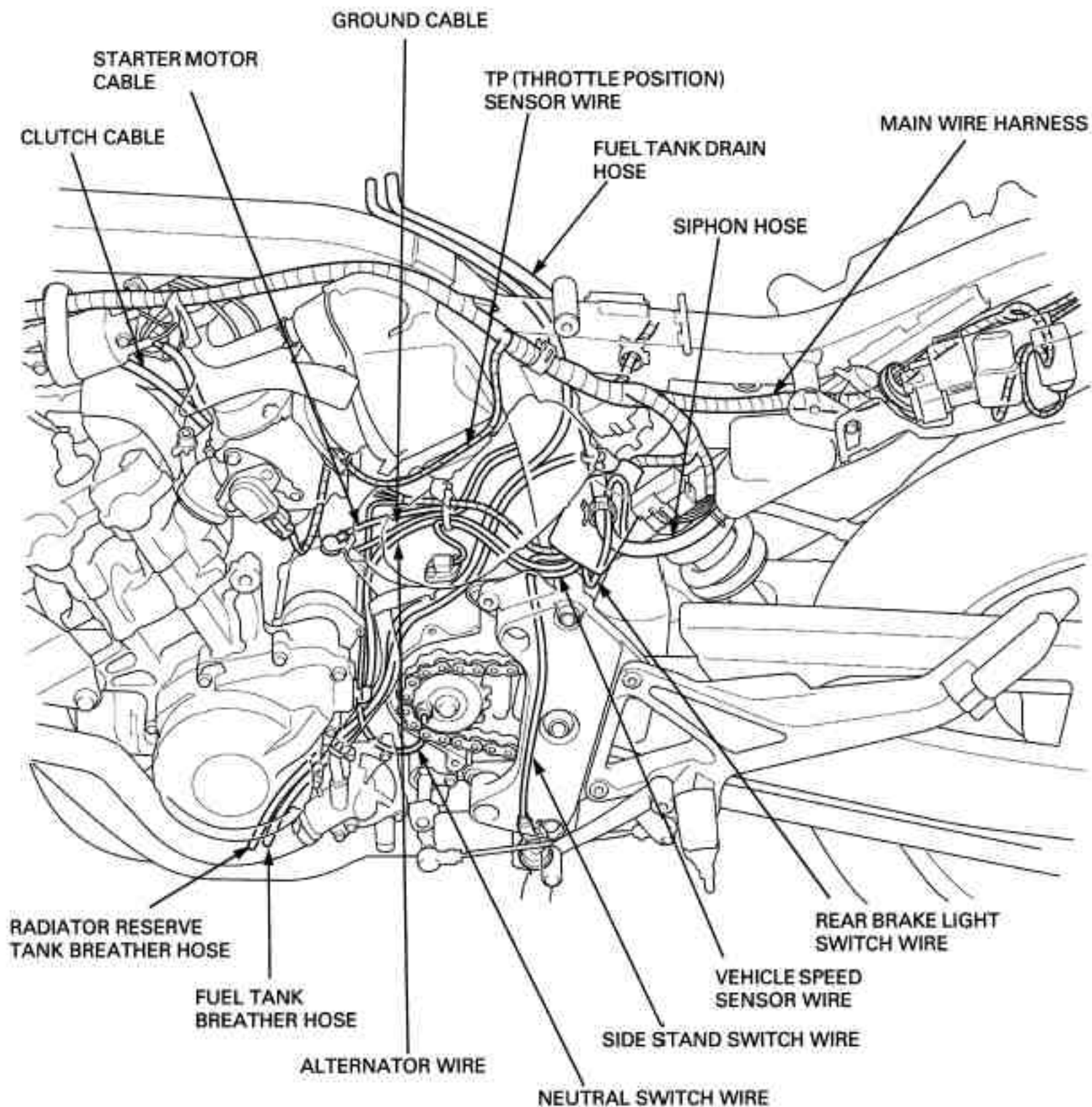

GENERAL INFORMATION

After '04 model:

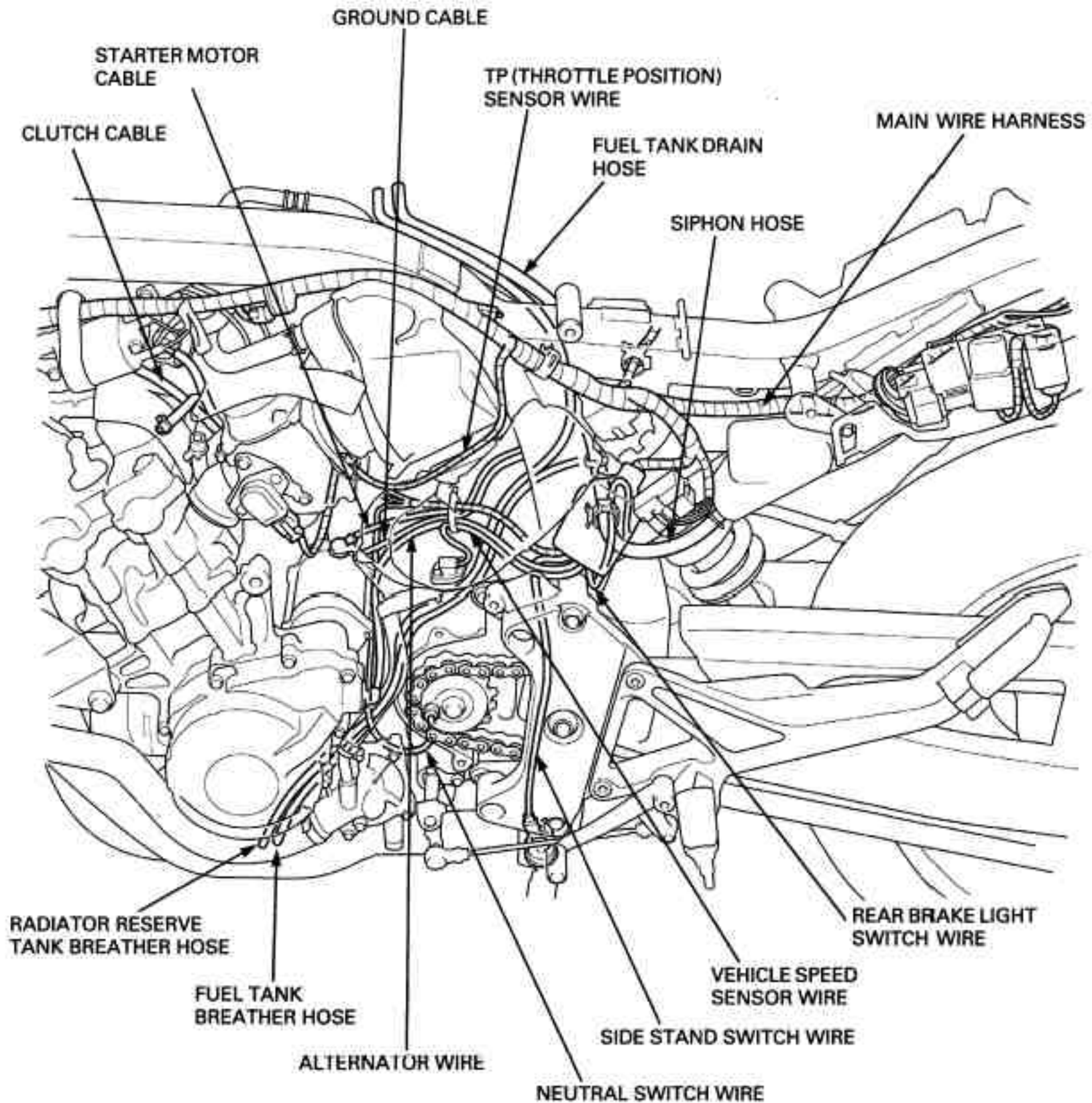

'04 model:

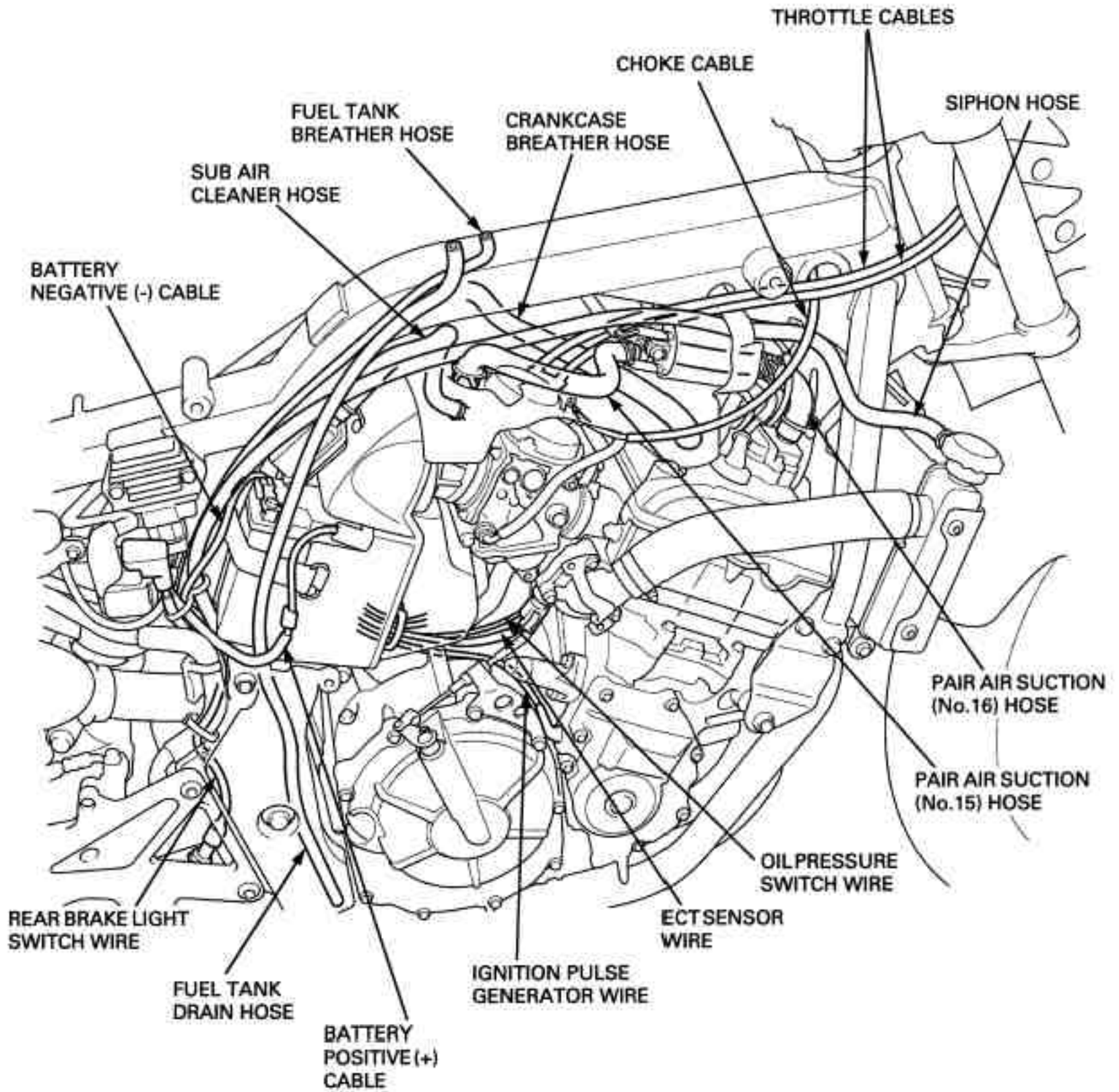

GENERAL INFORMATION

After '04 model:

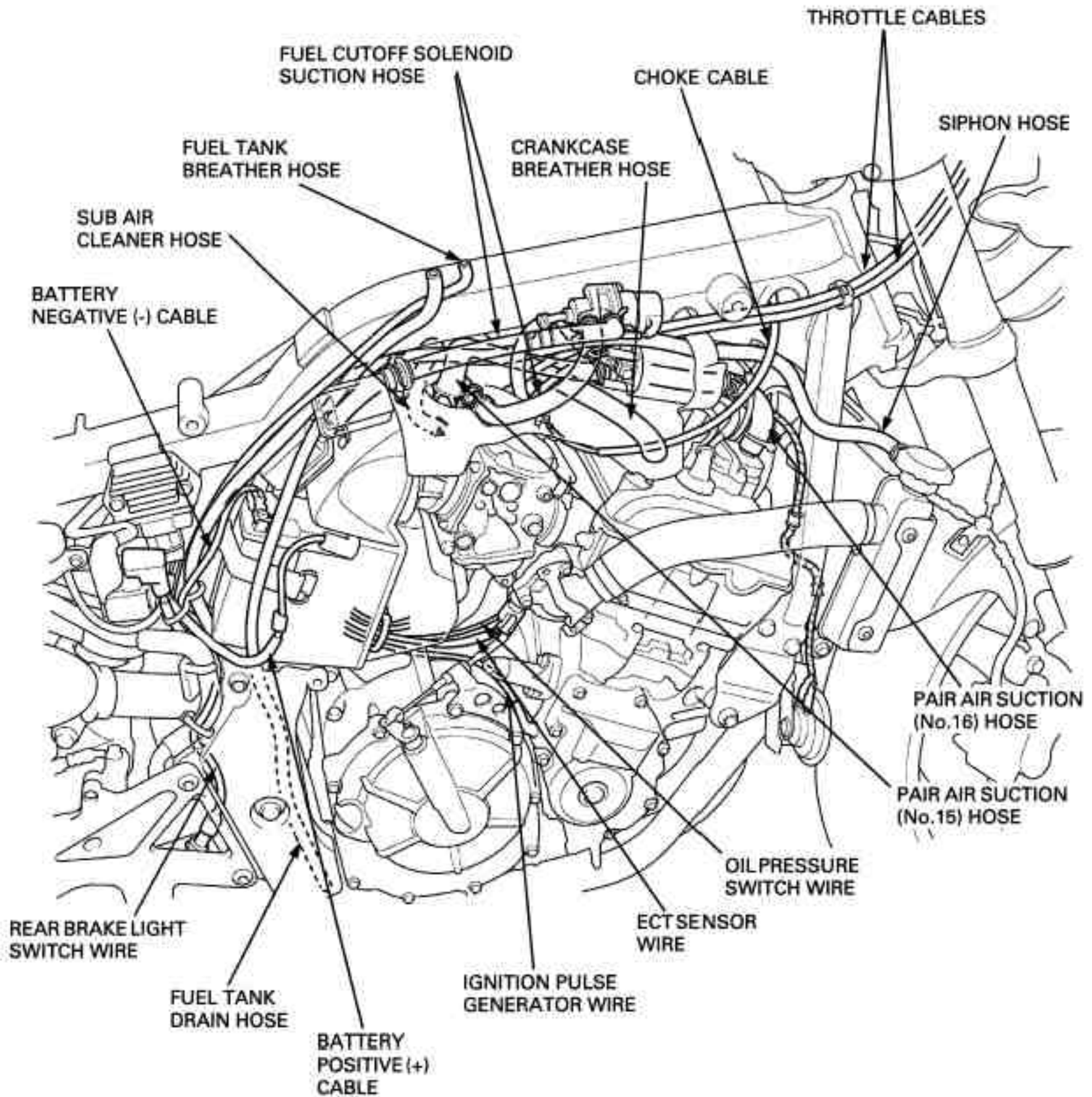

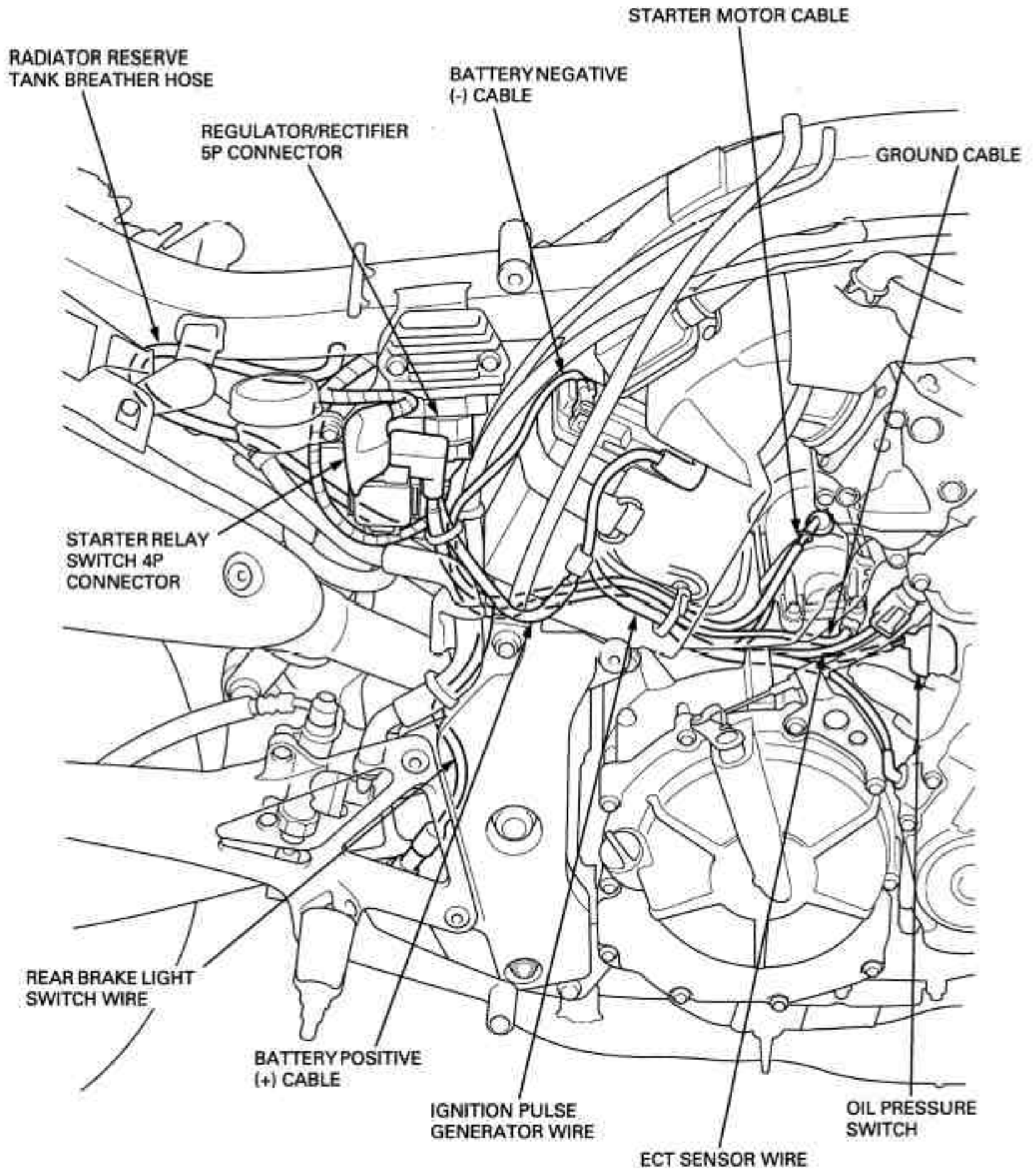

GENERAL INFORMATION

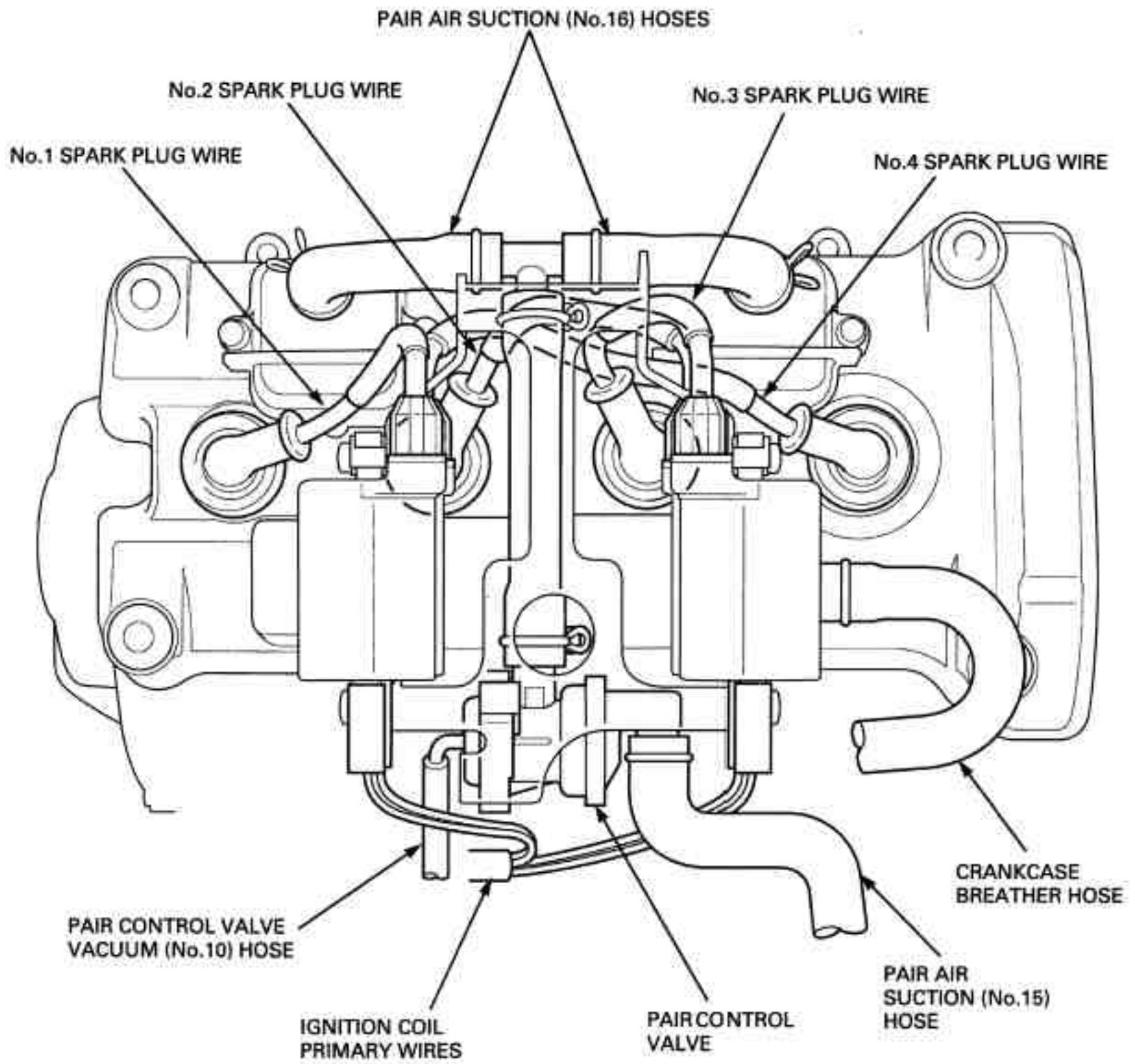

'04 model:

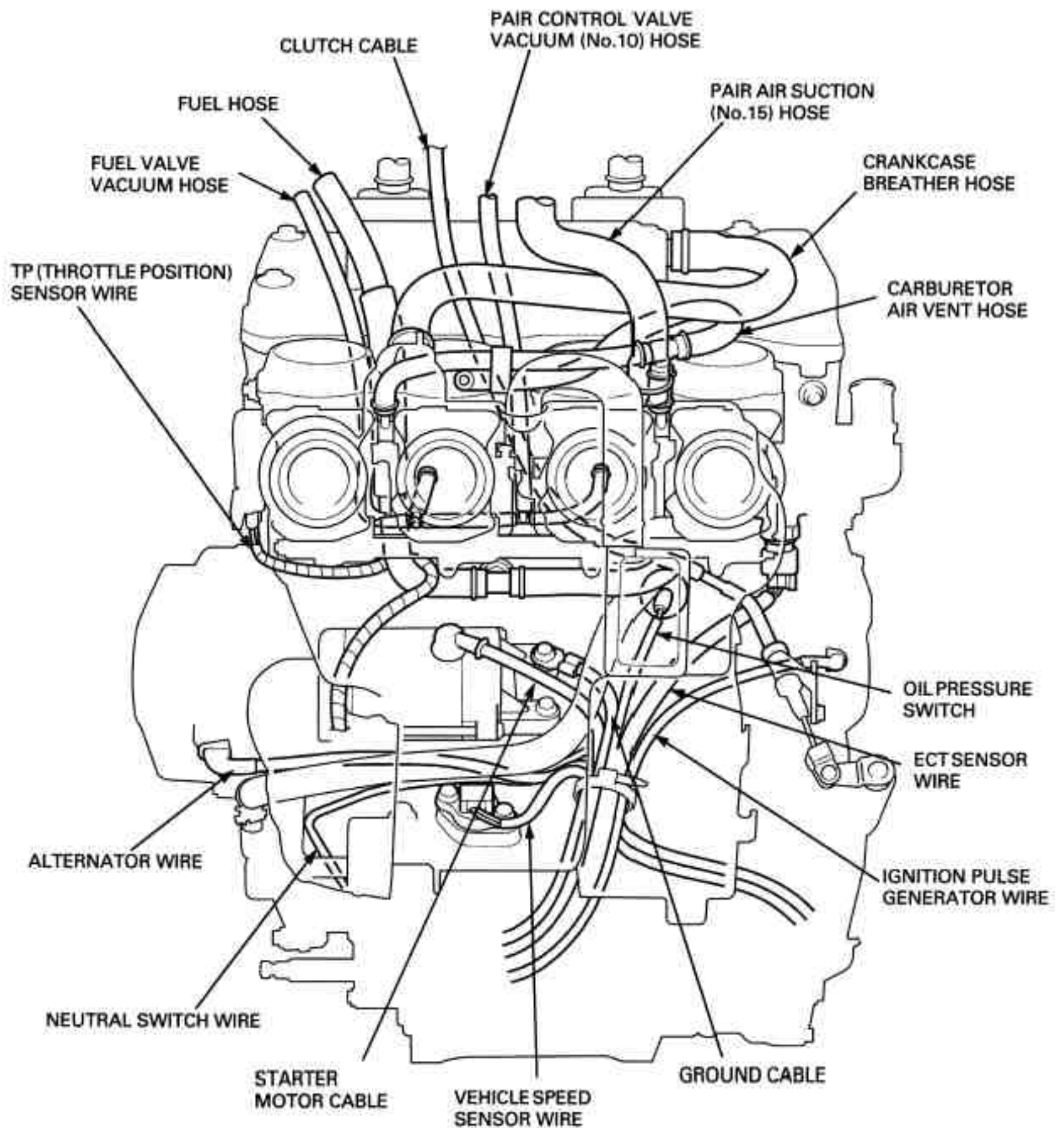

GENERAL INFORMATION

After '04 model:

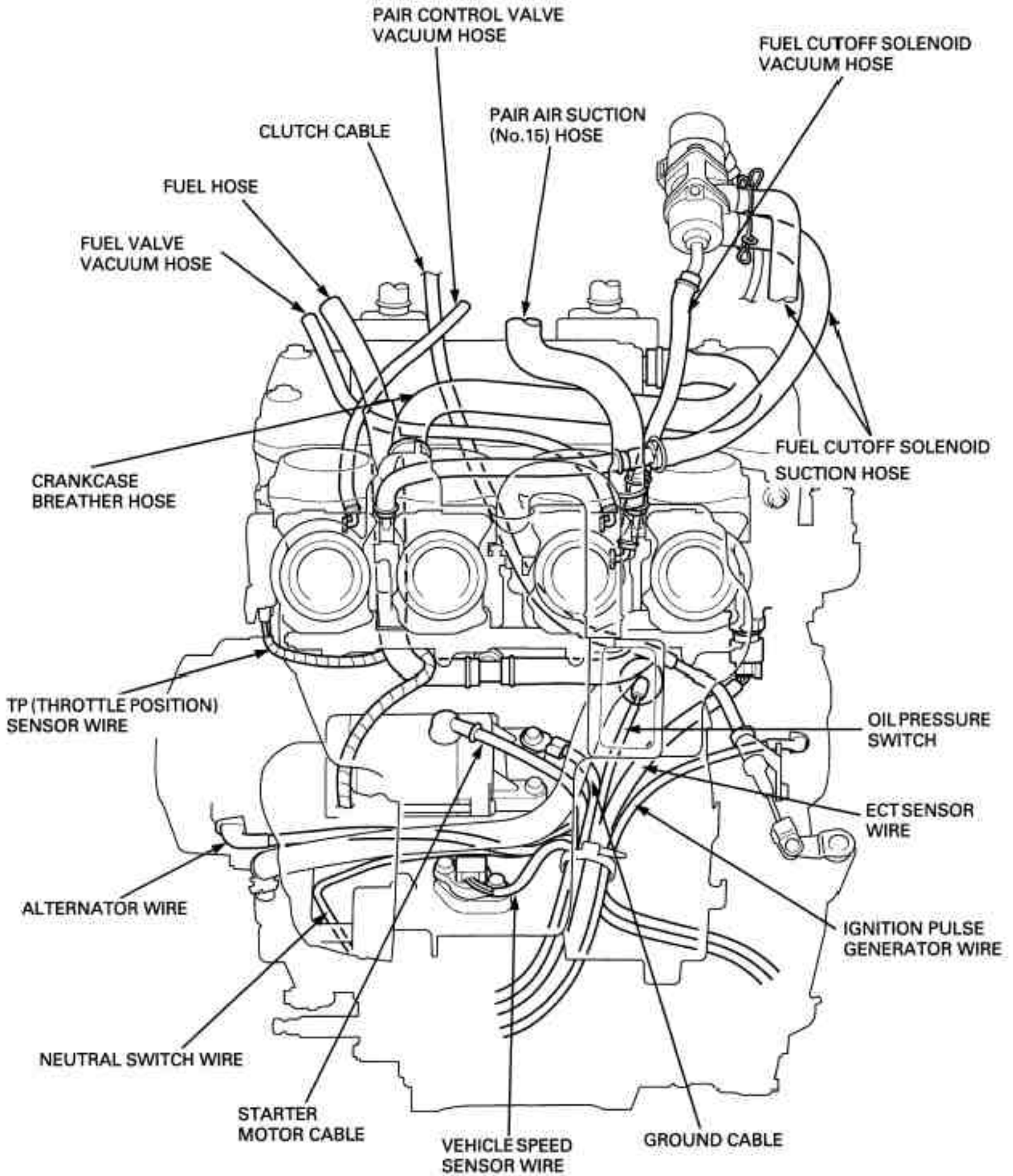

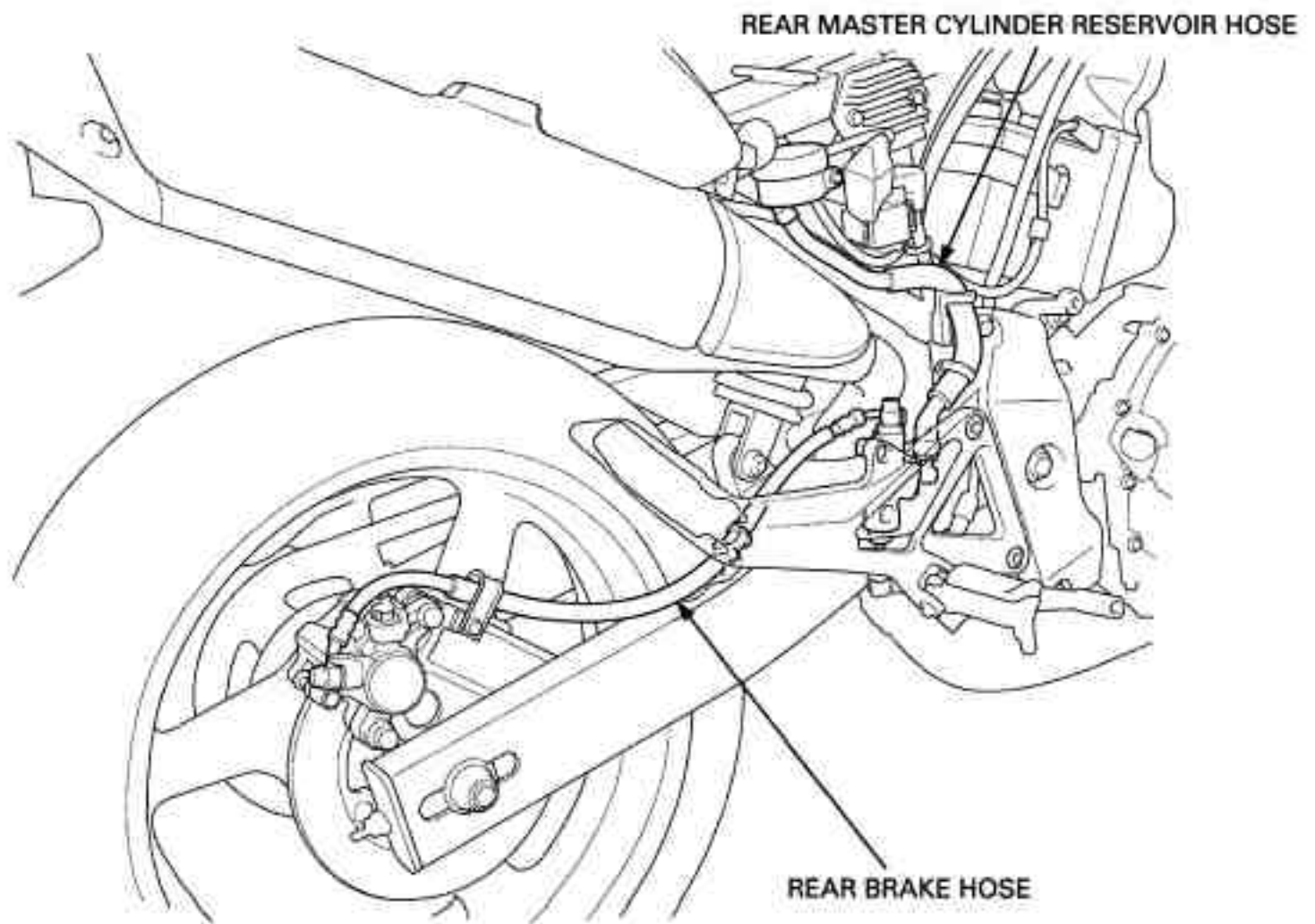
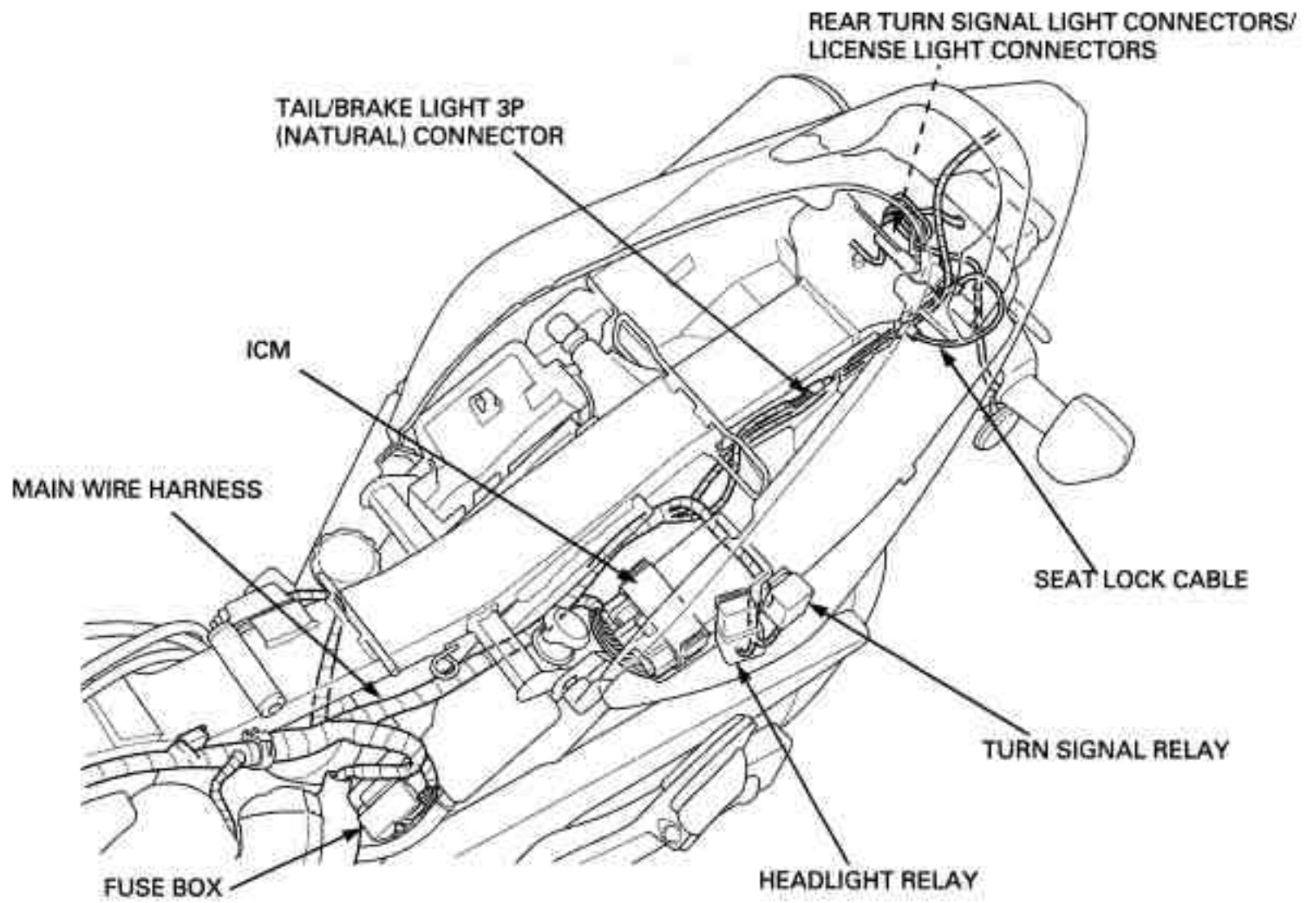

GENERAL INFORMATION

CALIFORNIA TYPE:

'04 model:

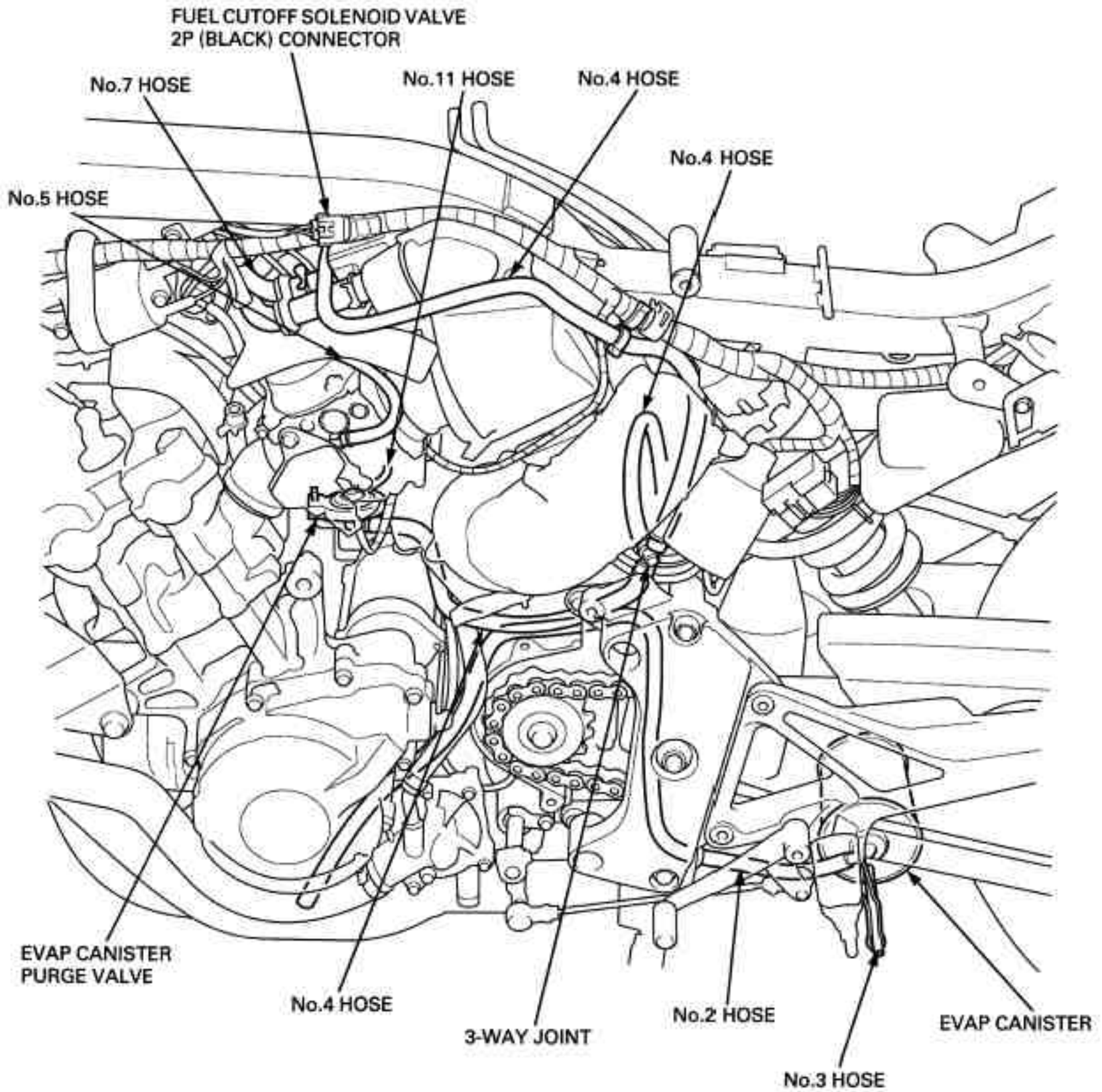

After '04 model:

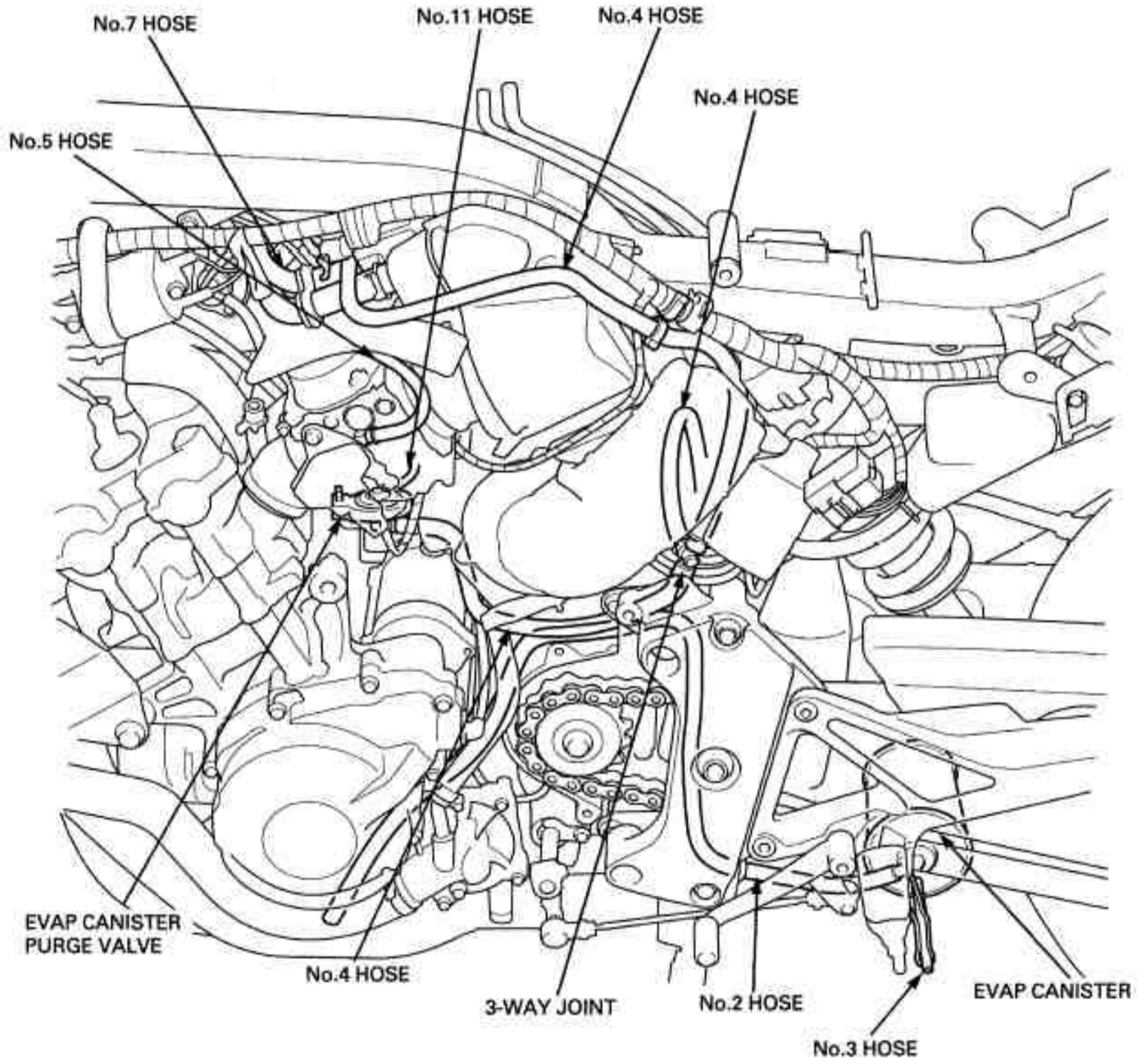

GENERAL INFORMATION

'04 model:

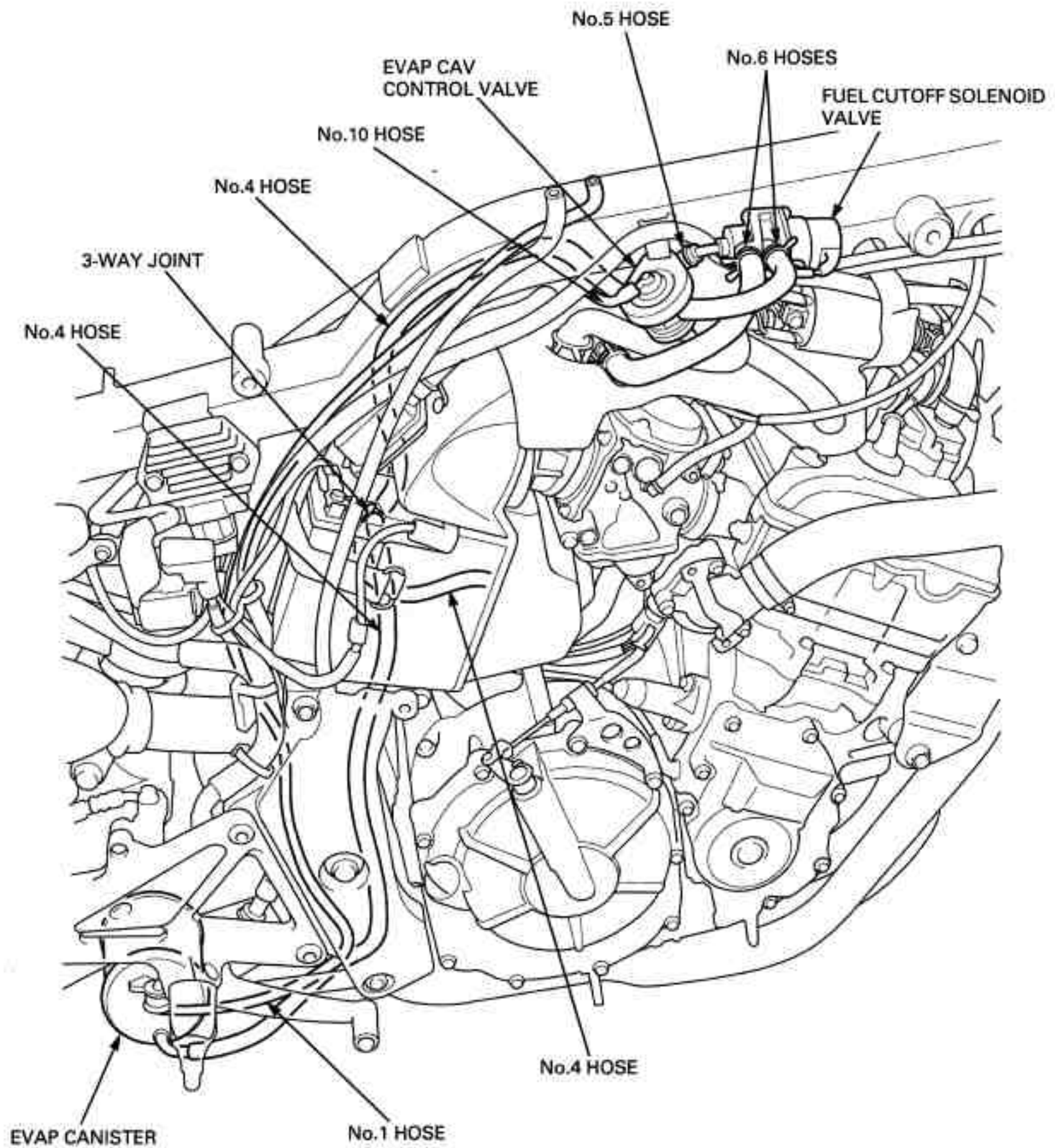

After '04 model:

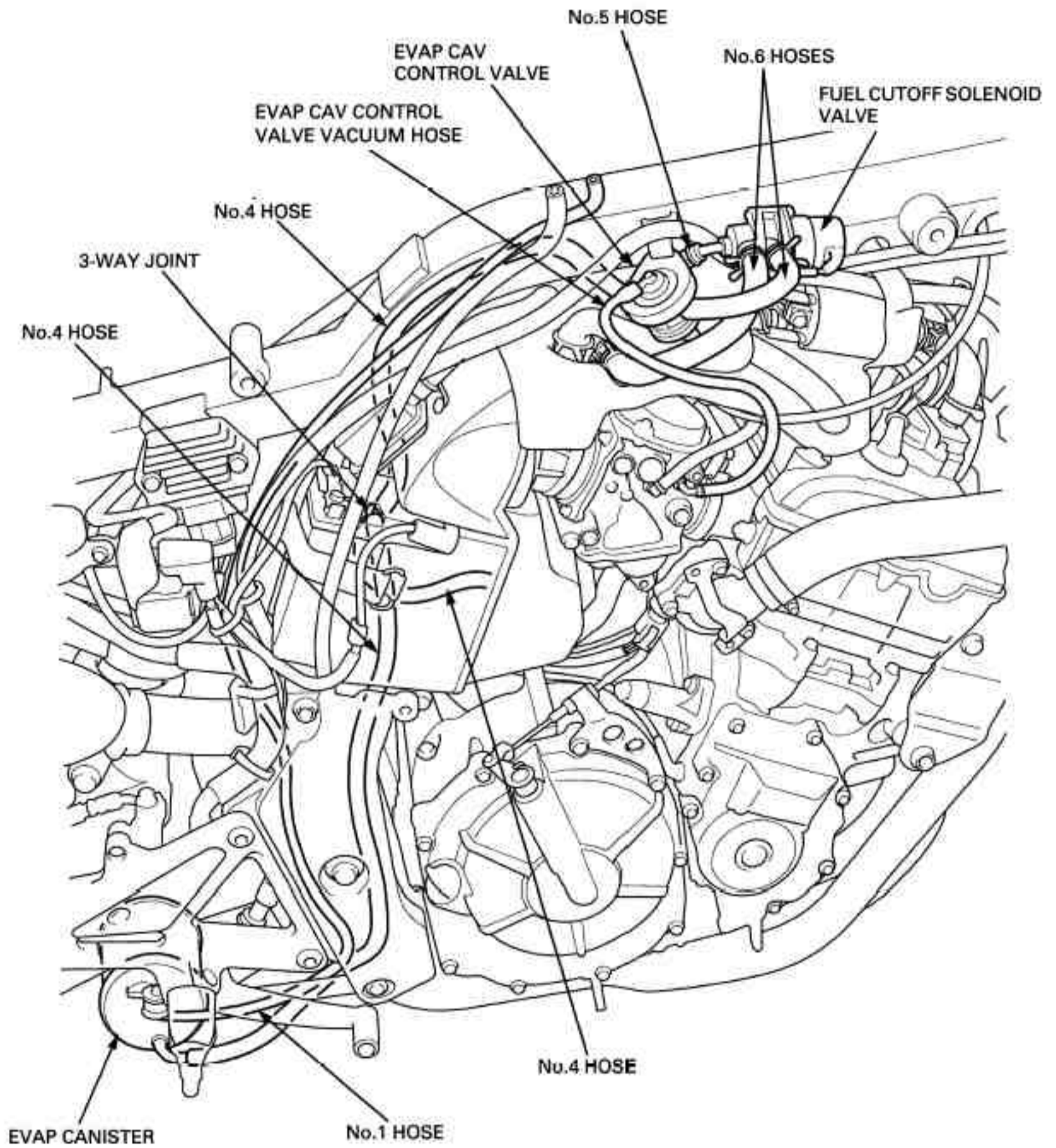

GENERAL INFORMATION

'04 model:

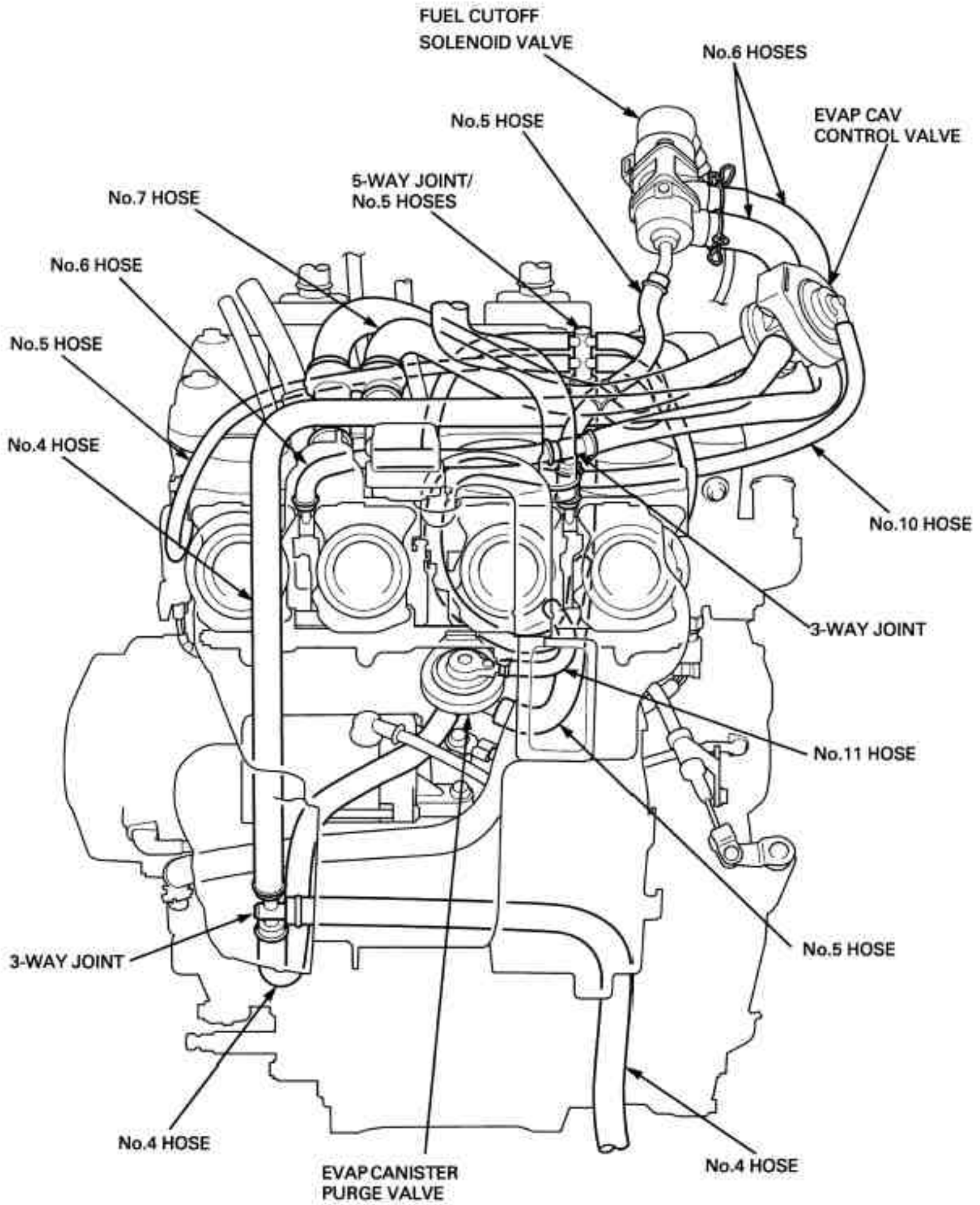

After '04 model:

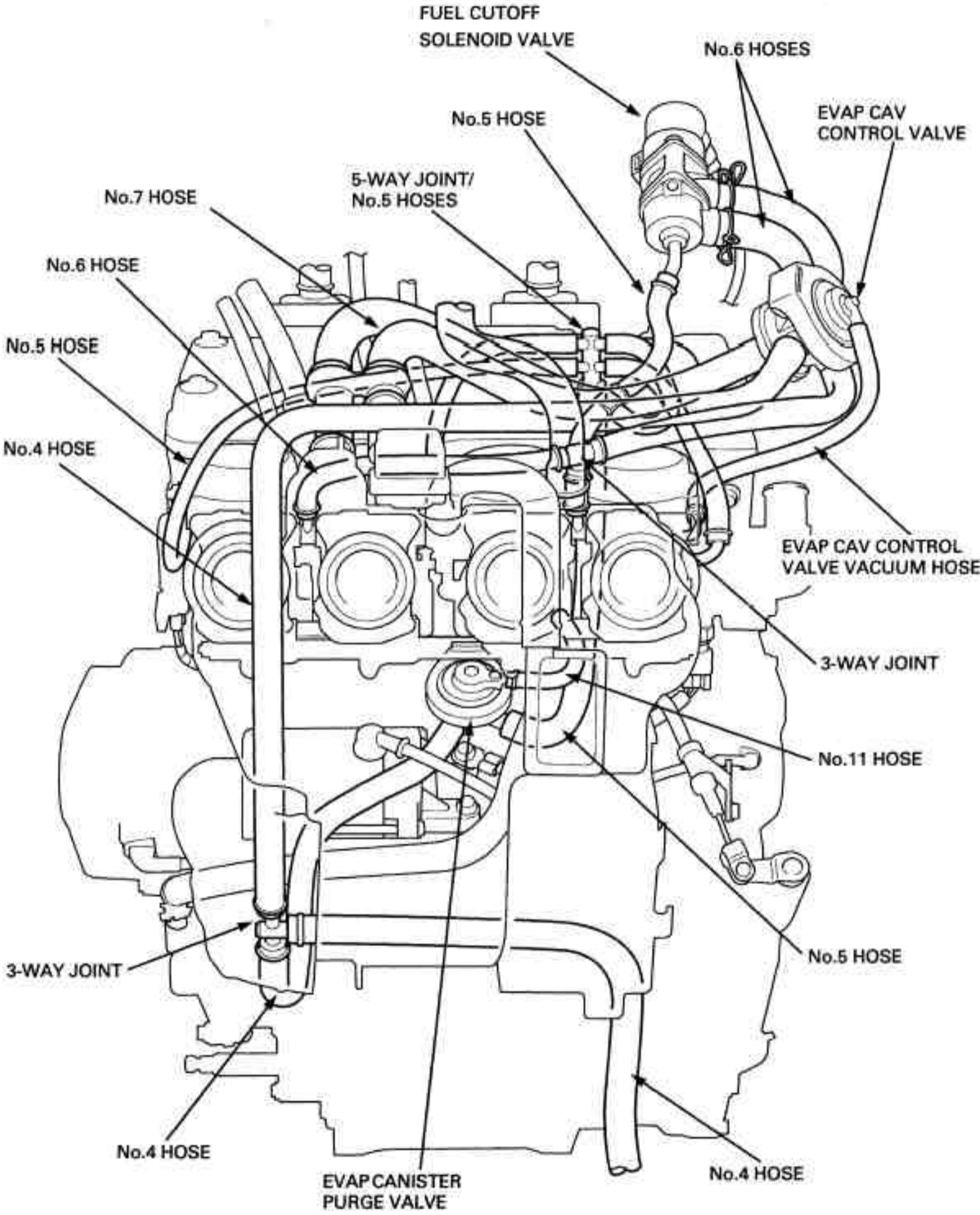

GENERAL INFORMATION

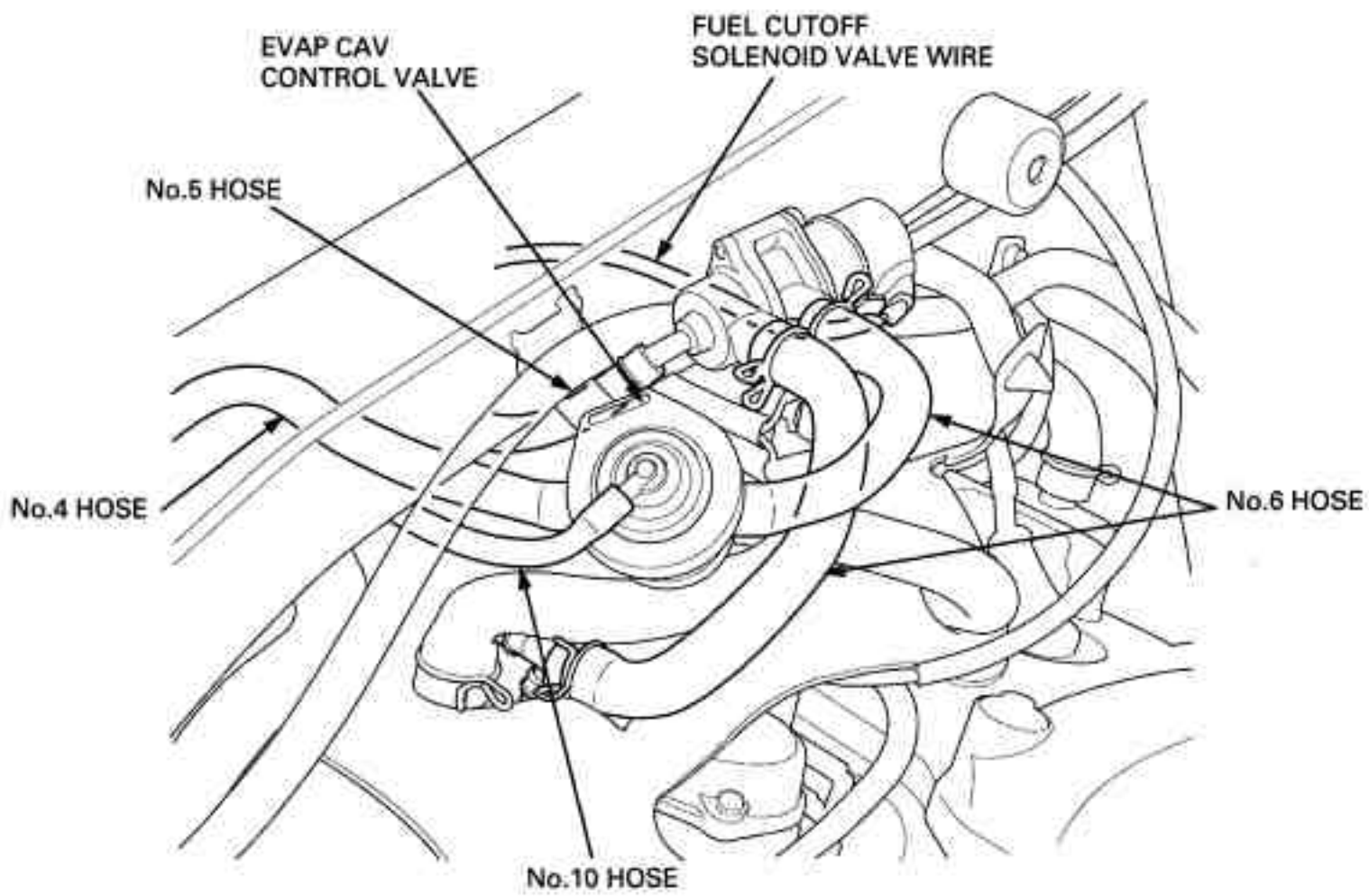
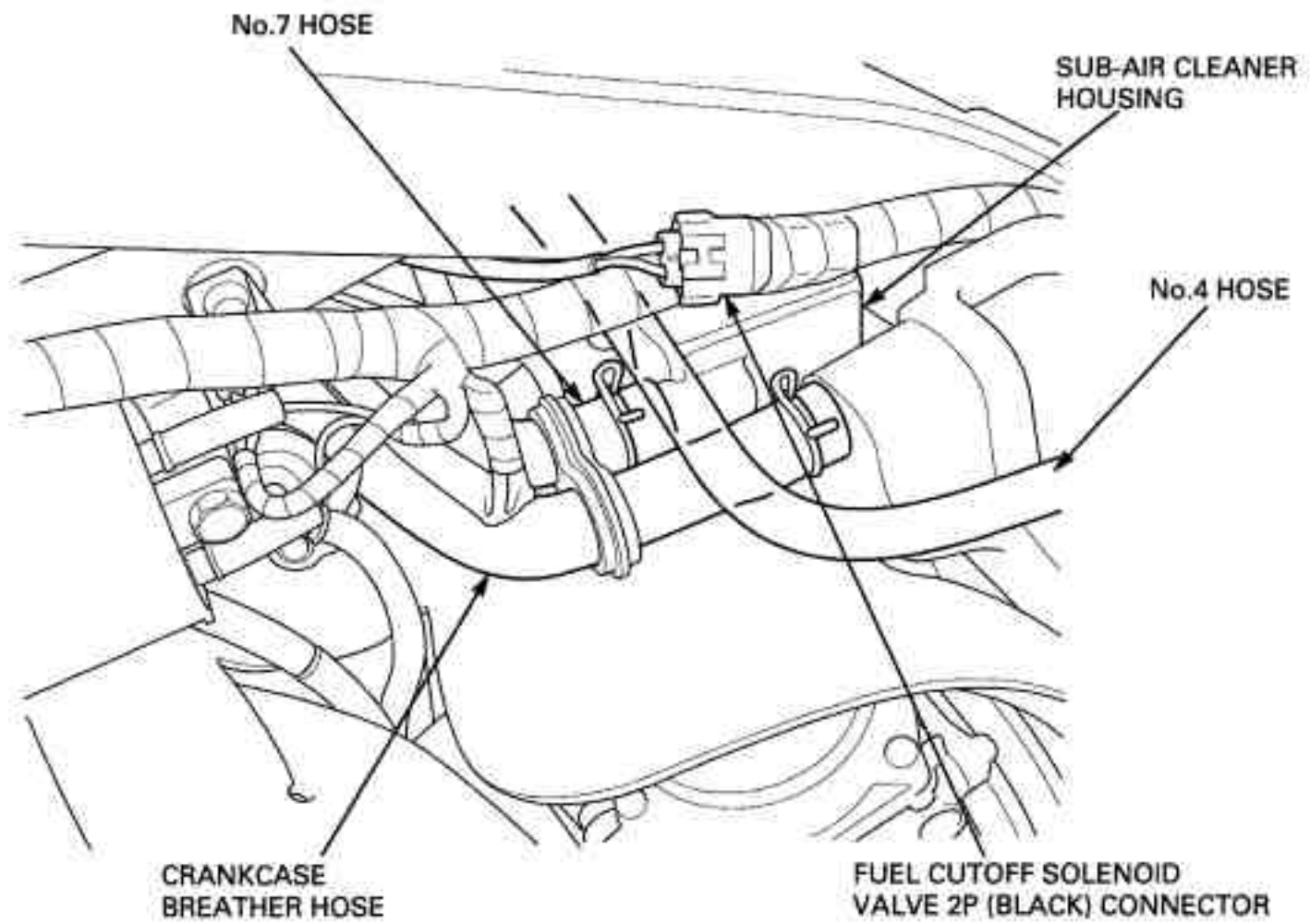

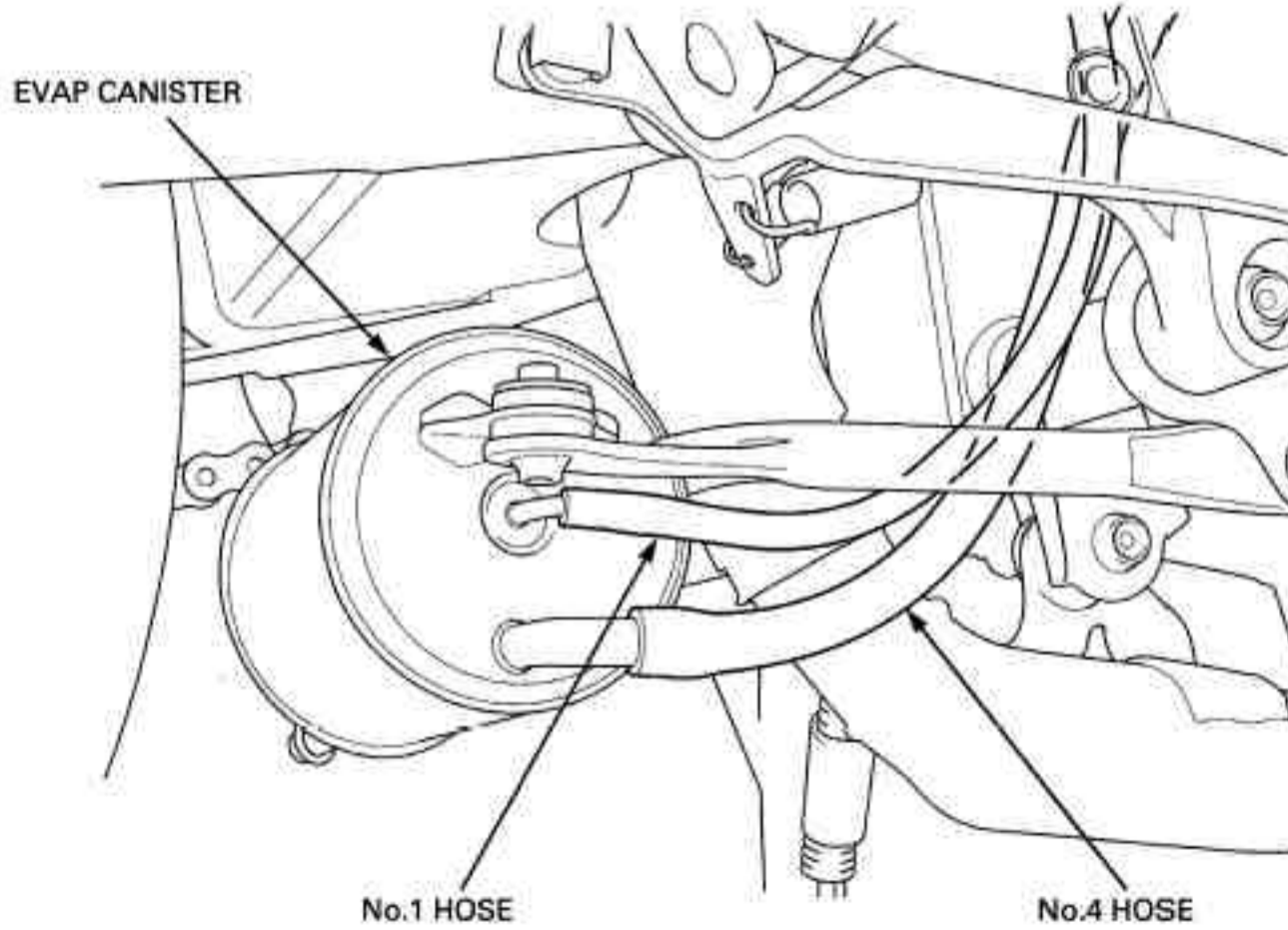
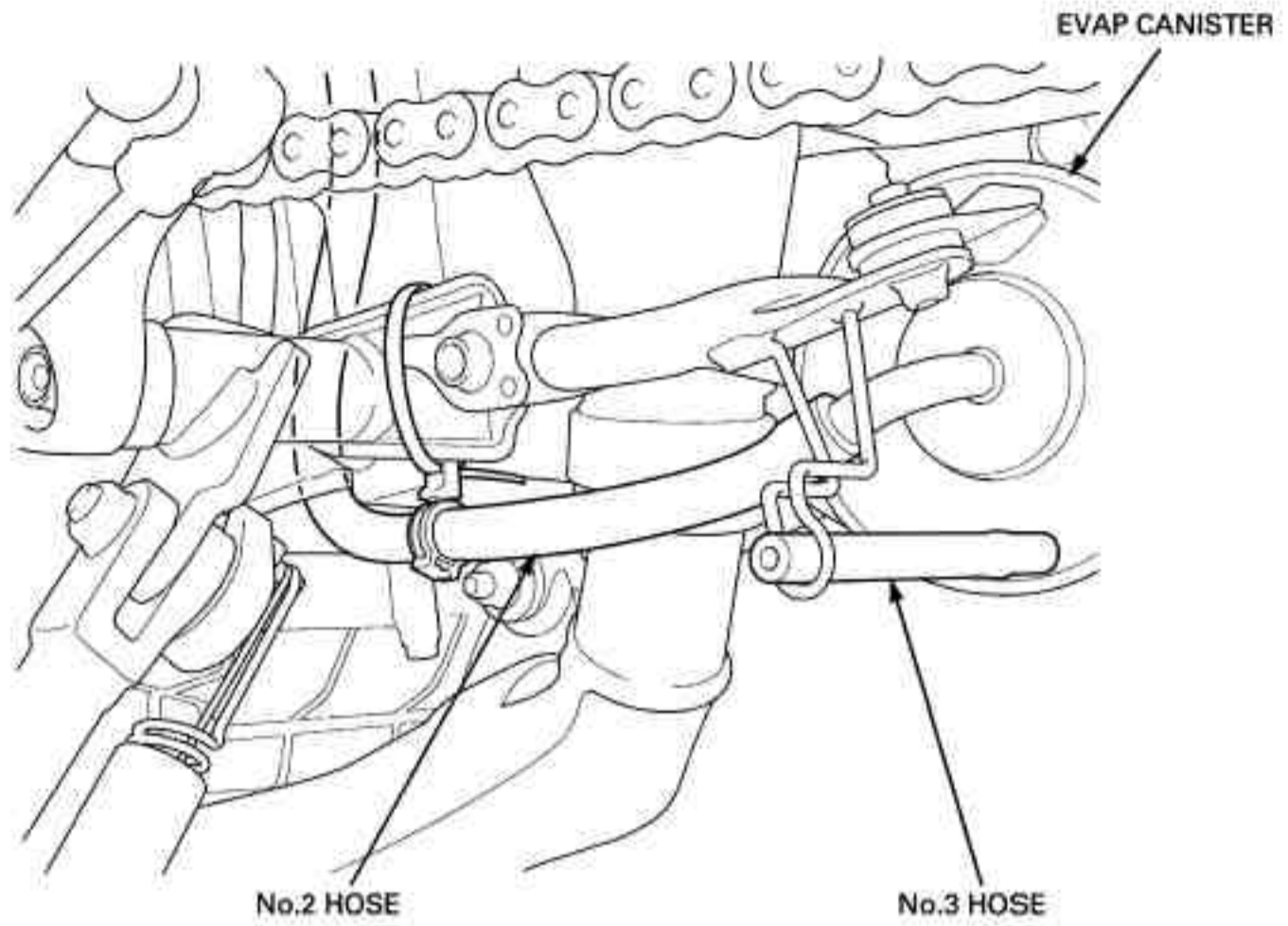

GENERAL INFORMATION

EMISSION CONTROL SYSTEMS

SOURCE OF EMISSIONS

The combustion process produces oxides of nitrogen, carbon monoxide and hydrocarbons. Control of oxides of nitrogen and hydrocarbons is very important because, under certain conditions, they react to form photochemical smog when subject to sunlight. Carbon monoxide does not react in the same way, but it is toxic.

Honda Motor Co., Ltd. utilizes lean carburetor settings as well as other systems, to reduce carbon monoxide and hydrocarbons.

CRANKCASE EMISSION CONTROL SYSTEM

The engine is equipped with a closed crankcase system to prevent discharging crankcase emissions into the atmosphere. Blow-by gas is returned to the combustion chamber through the air cleaner and carburetor body.

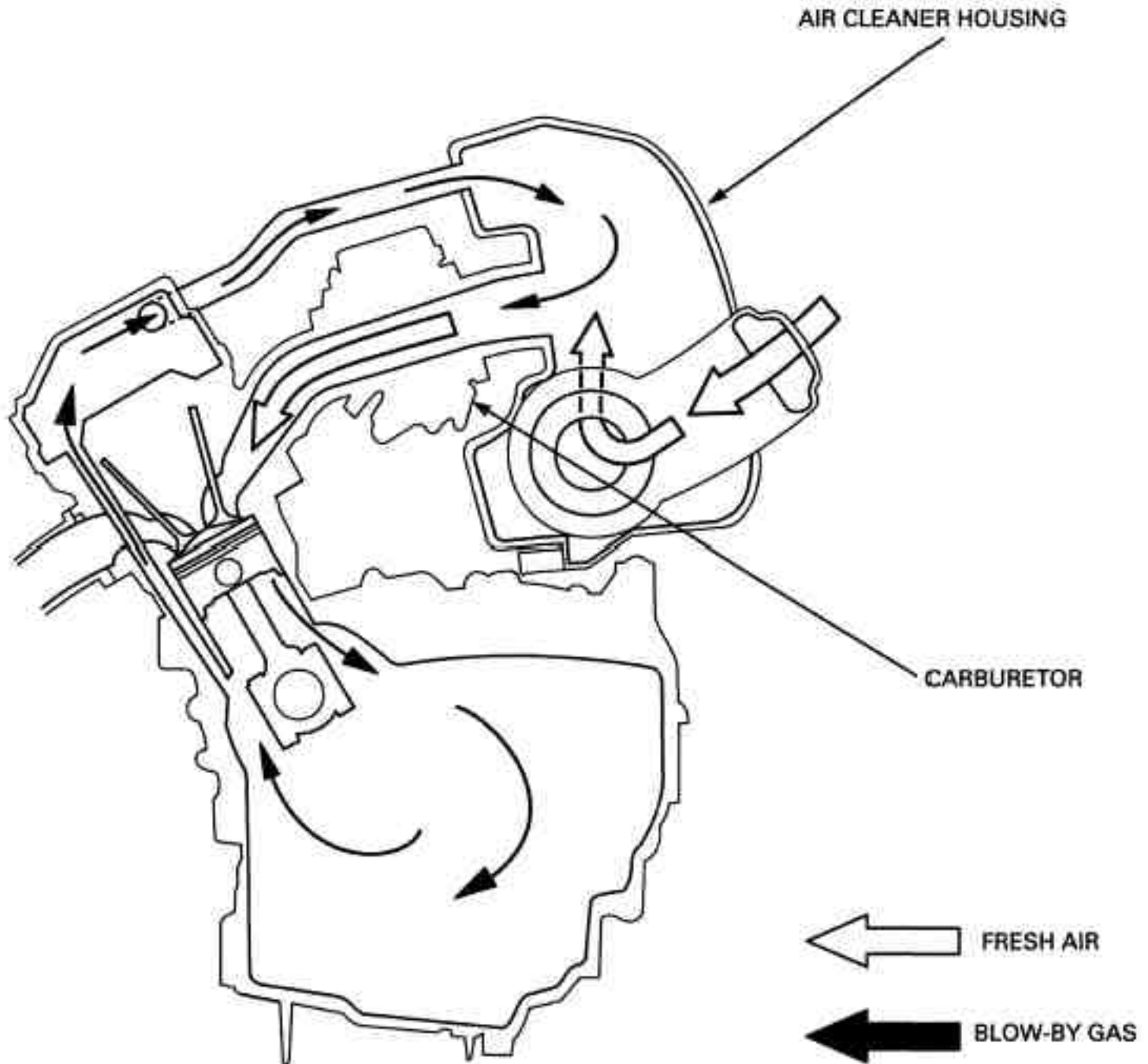

EXHAUST EMISSION CONTROL SYSTEM

The exhaust emission control system is composed of a pulse secondary air injection system and lean carburetor settings, no adjustment should be made except idle speed adjustment with the throttle stop screw.

PULSE SECONDARY AIR INJECTION SYSTEM

The pulse secondary air injection (PAIR) system introduces filtered air into the exhaust gases in the exhaust port. Fresh air is drawn into the exhaust port by the function of the PAIR (Pulse Secondary Air Injection) control valve.

The reed valve prevents reverse air flow through the system. The PAIR control valve reacts to high intake manifold vacuum and will cut off the supply of fresh air during engine deceleration, thereby preventing afterburn in the exhaust system.

No adjustments to the secondary air supply system should be made, although periodic inspection of the components is recommended.

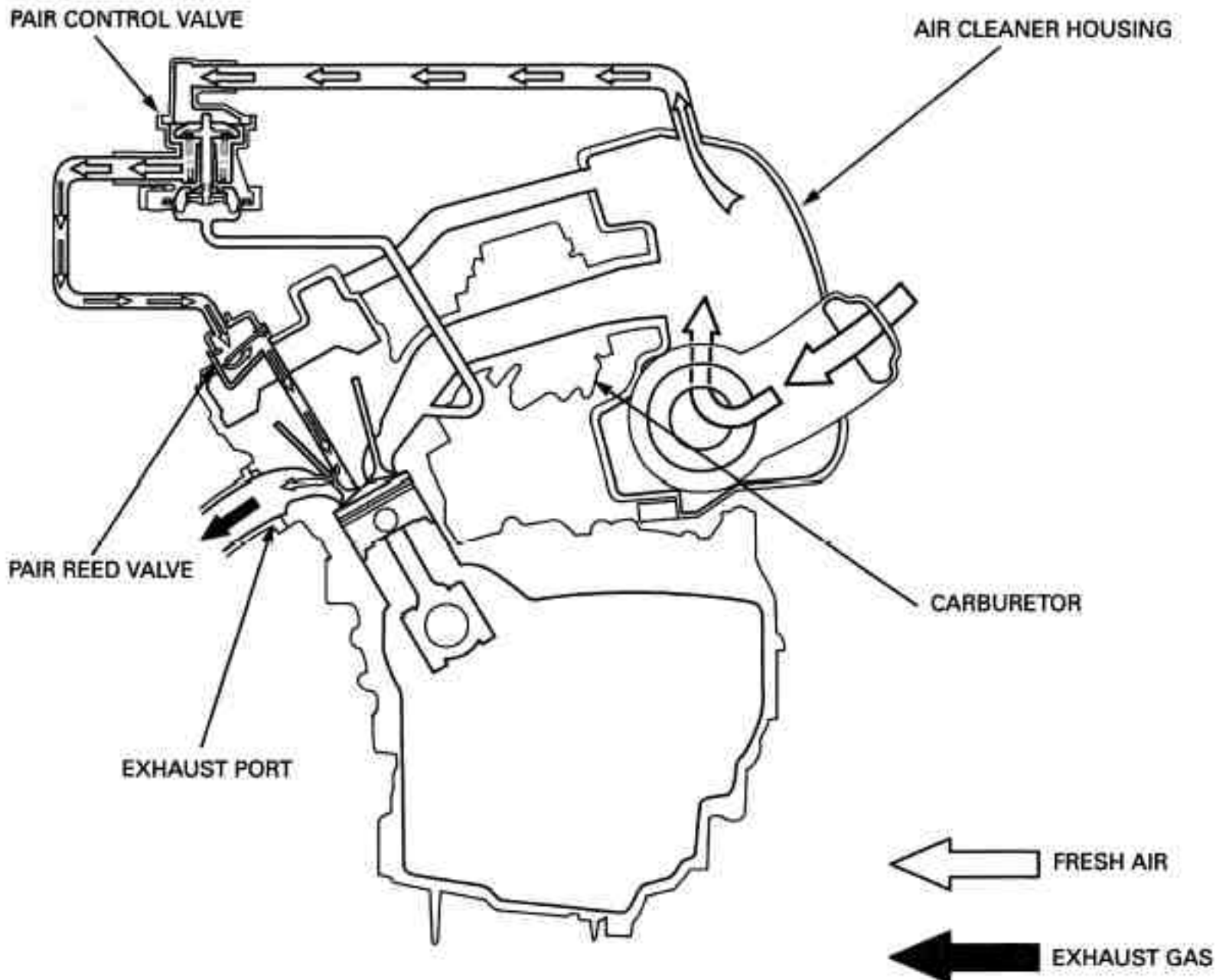

This motorcycle (California type) has oxidation catalytic converter. The oxidation catalytic converter is in the exhaust system. Through the chemical reactions, it converts HC and CO in the engine's exhaust to carbon dioxide (CO₂) and water vapor.

No adjustment to these systems should be made although periodic inspection of the components is recommended.

GENERAL INFORMATION

EVAPORATIVE EMISSION CONTROL SYSTEM (California type only)

This vehicle complies with the California Air Resources Board evaporative emission regulations.

Fuel vapor from the fuel tank and carburetors is routed into the evaporative emission canister where it is absorbed and stored while the engine is stopped. When the engine is running and the evaporative emission purge control valve is open fuel vapor in the evaporative emission canister is drawn into the engine through the carburetor. At the same time, the evaporative emission carburetor air vent solenoid valve is open and air is drawn into the carburetor through the valve.

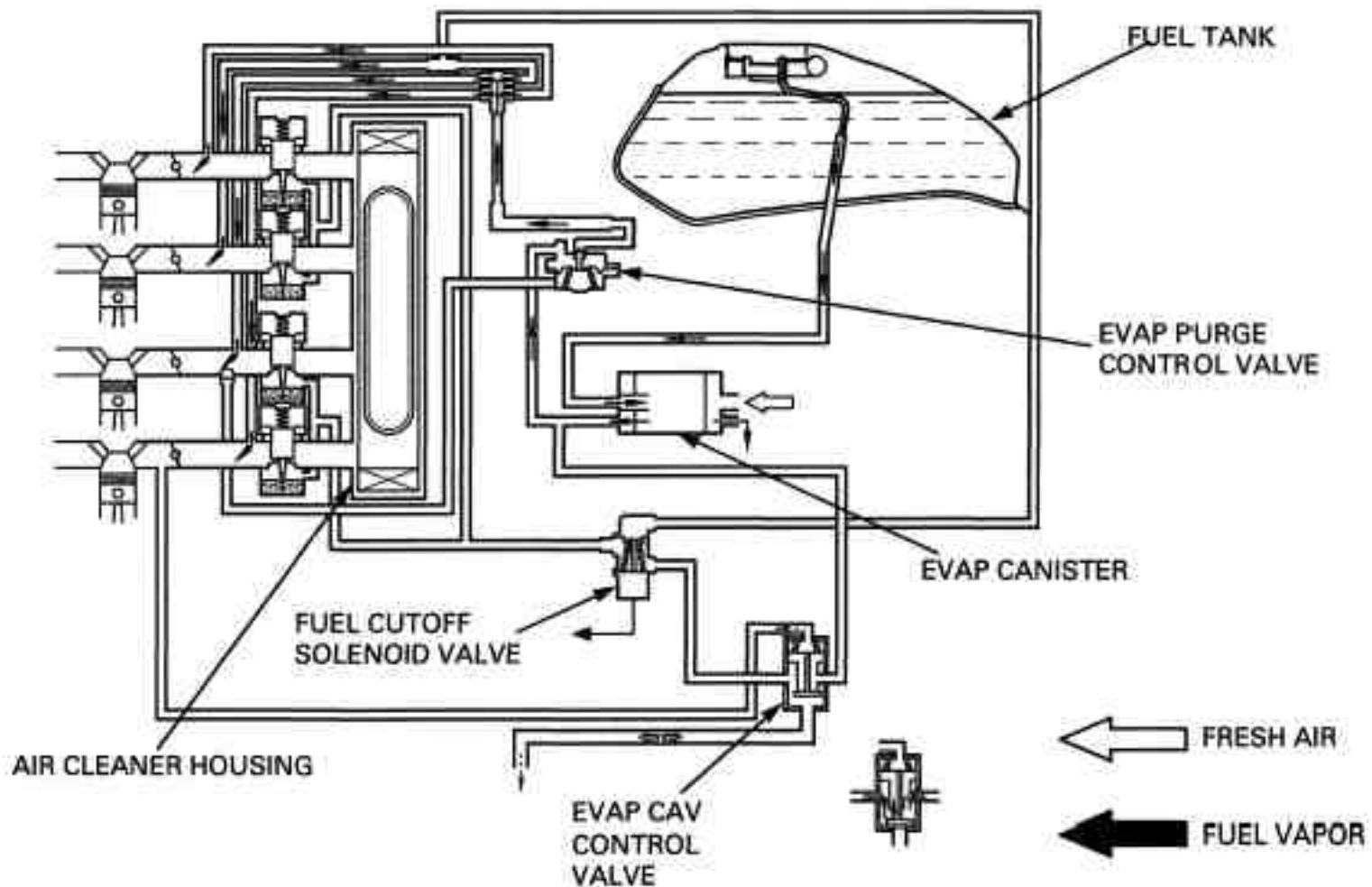

NOISE EMISSION CONTROL SYSTEM

TAMPERING WITH THE NOISE CONTROL SYSTEM IS PROHIBITED: U.S. Federal Law or Canadian Provincial Law prohibits the following acts or the causing thereof: (1) The removal or rendering inoperative by any person, other than for purposes of maintenance, repair or replacement, of any device or element of design incorporated into any new vehicle for the purpose of noise control prior to its sale or delivery to the ultimate purchaser or while it is in use; (2) the use of the vehicle after such device or element of design has been removed or rendered inoperative by any person.

AMONG THOSE ACTS PRESUMED TO CONSTITUTE TAMPERING ARE THE ACTS LISTED BELOW:

1. Removal of, or puncturing of the muffler, baffles, header pipes or any other component which conducts exhaust gases.
2. Removal of, or puncturing of any part of the intake system.
3. Lack of proper maintenance.
4. Replacing any moving parts of the vehicle, or parts of the exhaust or intake system, with parts other than those specified by the manufacturer.

EMISSION CONTROL INFORMATION LABELS

An Emission Control Information Label is located on the right side of the swingarm as shown. It gives basic tune-up specifications.

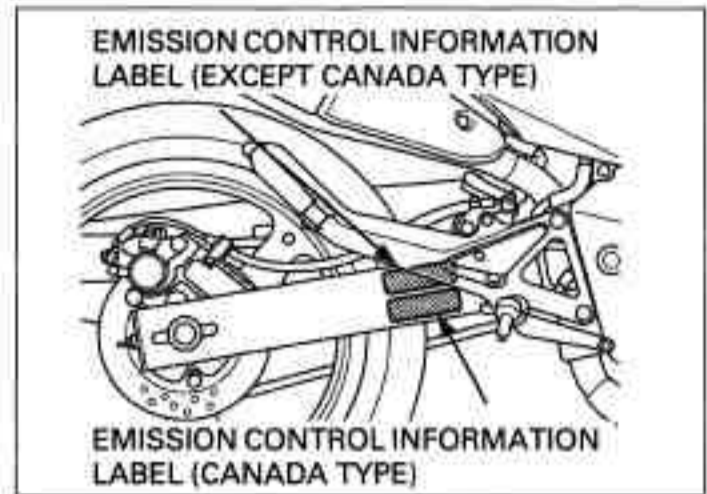

VEHICLE EMISSION CONTROL INFORMATION UPDATE LABEL

After making a high altitude carburetor adjustment, attach an update label on the frame as shown.

The seat must be removed to read it. Refer to page 3-4 for the seat removal.

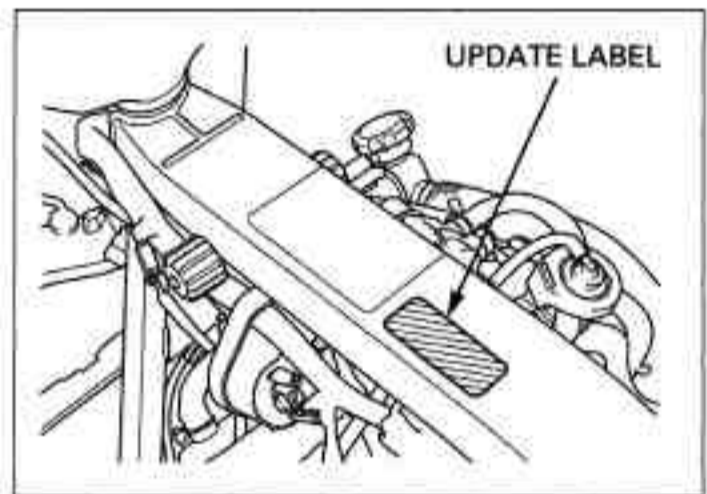

GENERAL INFORMATION

VACUUM HOSE ROUTING LABEL (California type only: '04 model only)

The Vacuum Hose Routing Label is on the frame as shown.
the seat must be removed to read it. Refer to page 3-4 for the seat removal.

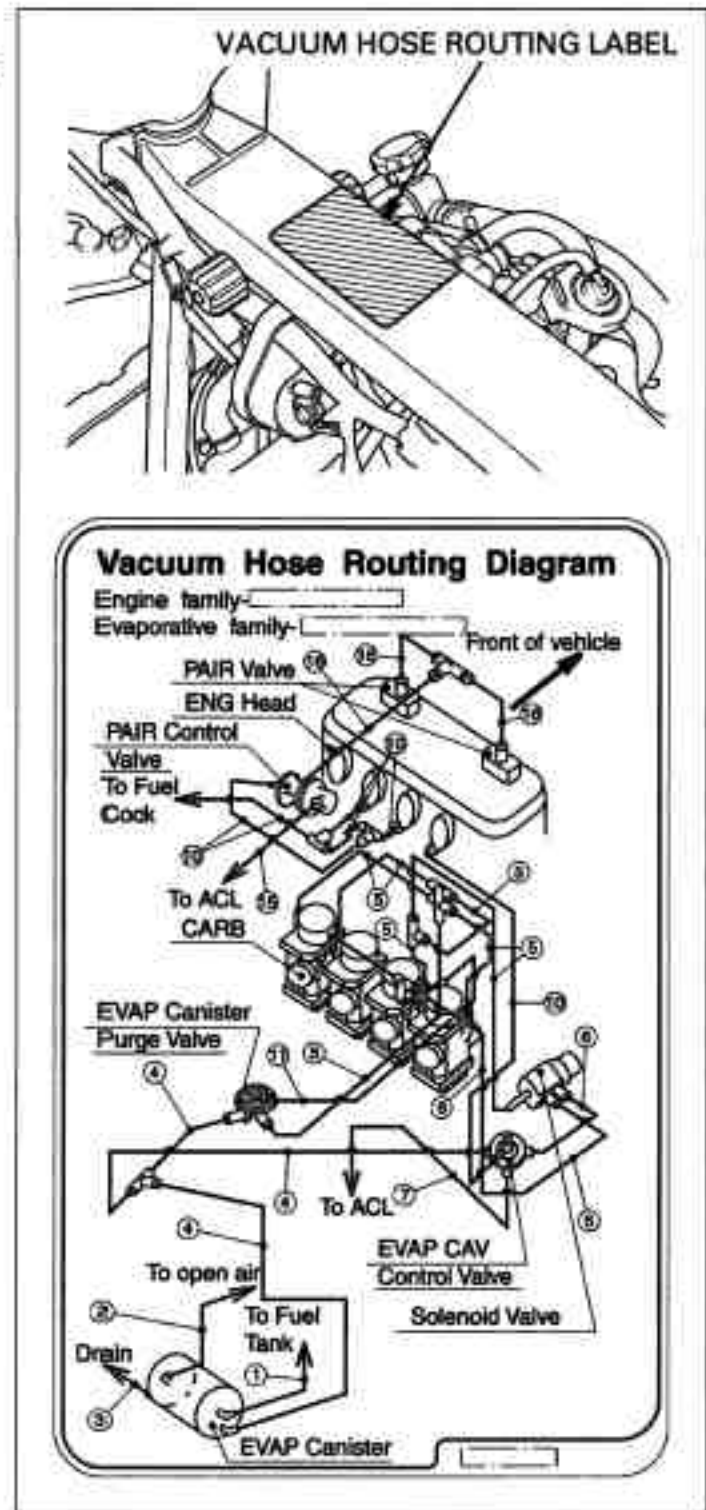

2. TECHNICAL FEATURE

FUEL CUTOFF SOLENOID VALVE 2-2

TECHNICAL FEATURE

FUEL CUTOFF SOLENOID VALVE

OUTLINE

This motorcycle has oxidation catalytic converter. Through the chemical reactions, it converts HC and CO in the engine's exhaust to carbon dioxide (CO₂) and water vapor.

If the unburned (raw) gasoline from the combustion chamber flows into the catalytic converter, it will damage the catalytic converter through excessive temperatures. A damaged catalytic converter cannot be effective for exhaust emissions control.

Raw gasoline can enter the catalytic converter under the following conditions:

- The engine stop switch is turned to "OFF" suddenly while the engine is running.
- Ignition cut system (rev limiter) operates when the engine is over revved.

The fuel cutoff solenoid valve protects the oxidation catalytic converter from the unburned gasoline flow by stopping the fuel flow.

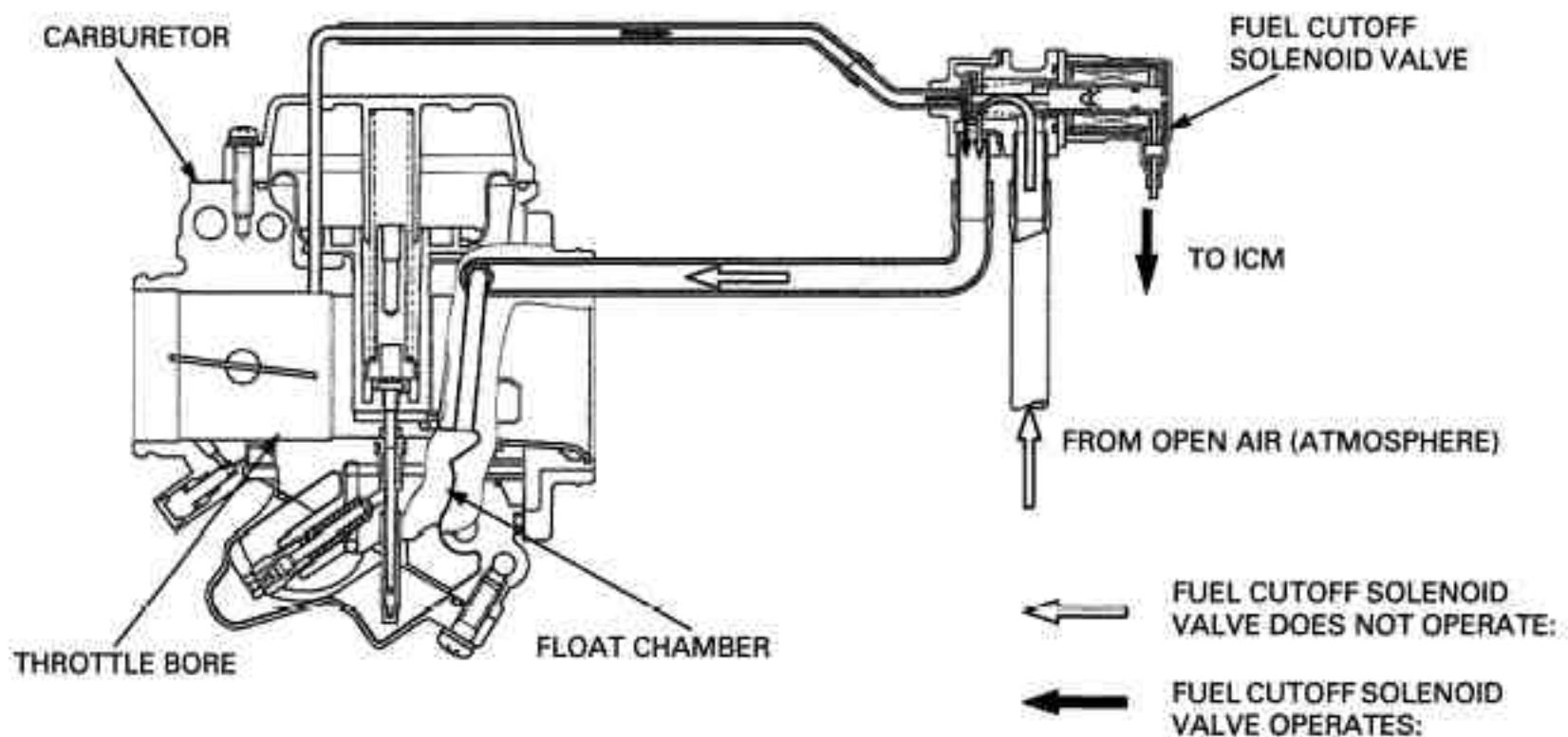

CONSTRUCTION

The fuel cutoff solenoid valve is controlled by the ICM, and the float chamber air vent is changed according to above described conditions:

The fuel cutoff solenoid valve consists of a coil and valve, and 3 passages.

1. Connection to atmosphere
2. Connection to throttle bore
3. Connection to float chamber air vent

The fuel cutoff solenoid valve opens passages 1 to 3 passage when there is no operation voltage.

OPERATION

Normal Operation (When the fuel cutoff solenoid valve does not operate):

1. No operation voltage from the ICM.
2. The float chamber air vent is open to atmosphere.
3. The float chamber pressure (surface of the gasoline in the float chamber) is atmosphere.
4. The carburetor operates normally.

Fuel Cut Operation (When the fuel cutoff solenoid valve operates):

1. The operation voltage comes from the ICM.
2. The float chamber air vent passage is closed to atmosphere.
3. The float chamber air vent is opened to the throttle bore.
4. The float chamber pressure (surface of the gasoline in the float chamber) becomes negative.
5. The float chamber pressure will be same as throttle bore pressure.
6. The carburetor stops fuel supply.

3. FRAME/BODY PANELS/EXHAUST SYSTEM

BODY PANEL LOCATIONS	3-2	FUEL TANK	3-6
SERVICE INFORMATION	3-3	FRONT FENDER ('04 model)	3-7
TROUBLESHOOTING	3-3	FRONT FENDER (After '04 model)	3-7
SEAT	3-4	REAR FENDER	3-8
SIDE COVER	3-4	METER VISOR (After '04 model)	3-8
REAR COWL	3-5	MUFFLER/EXHAUST PIPE	3-9

FRAME/BODY PANELS/EXHAUST SYSTEM

BODY PANEL LOCATIONS

'04 model:

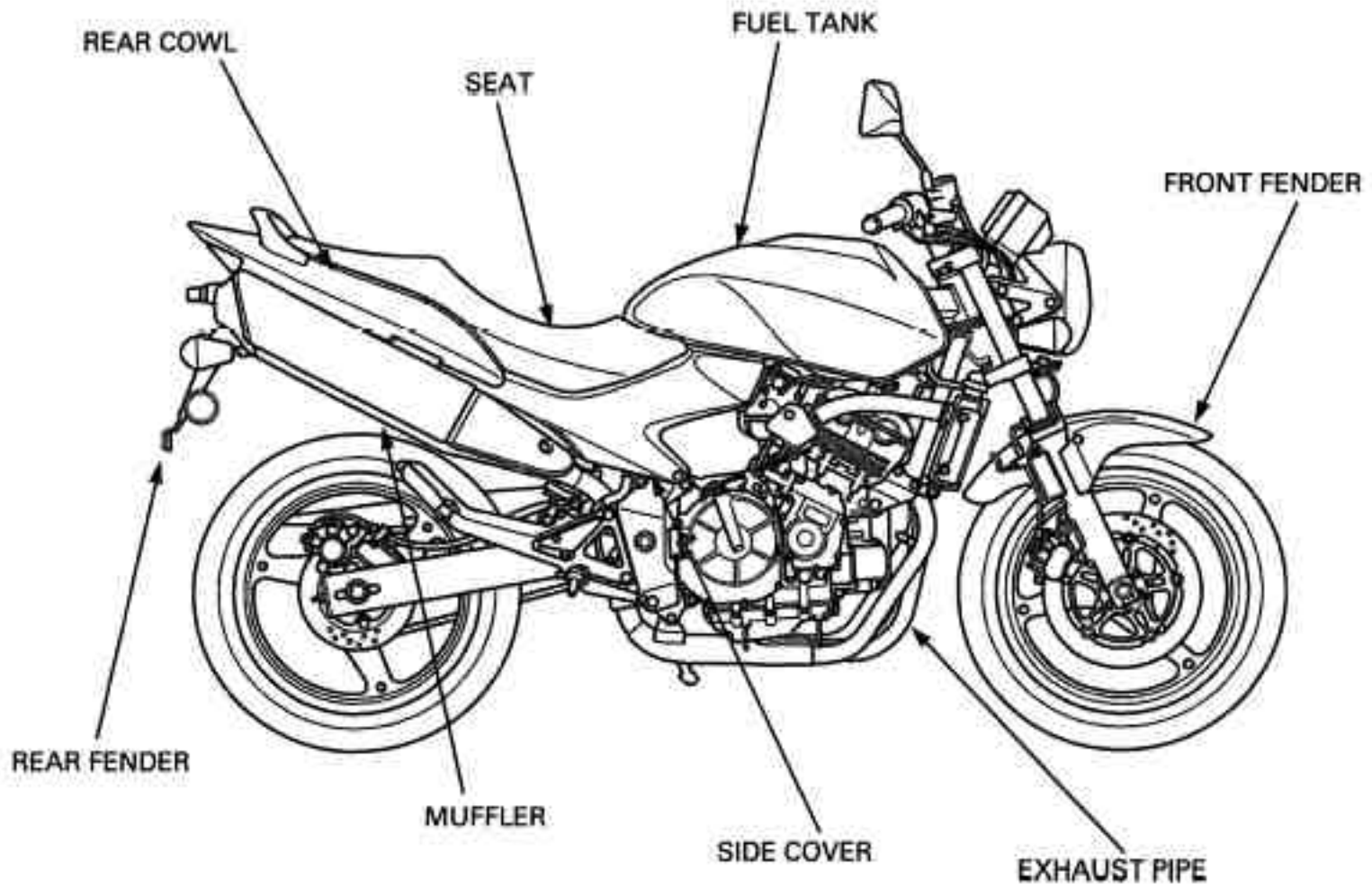

After '04 model:

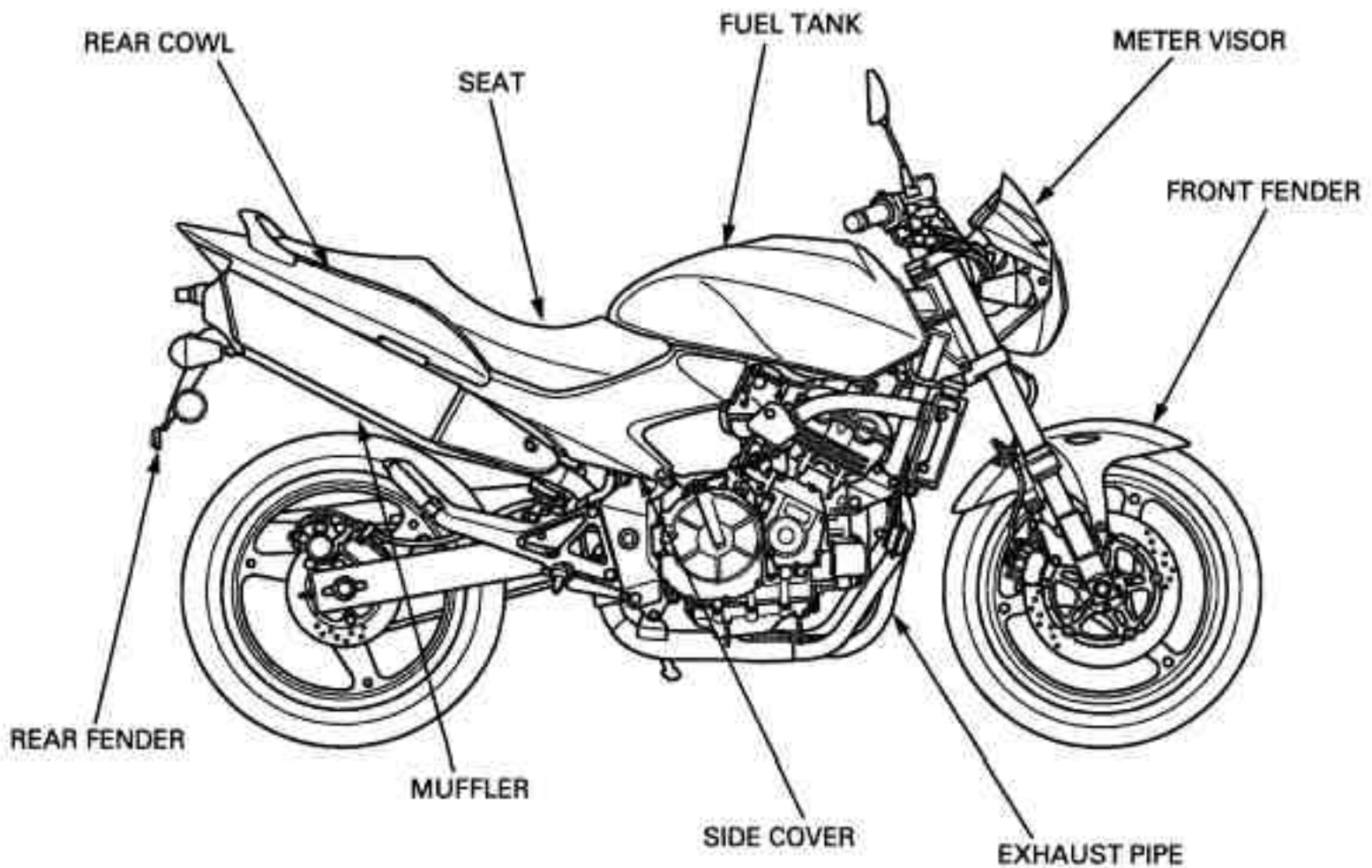

SERVICE INFORMATION

GENERAL

- Work in a well ventilated area. Smoking or allowing flames or sparks in the work area or where gasoline is stored can cause a fire or explosion.
- This section covers removal and installation of the body panels and exhaust system.
- Serious burns may result if the exhaust system is not allowed to cool before components are removed or serviced.
- Always replace the exhaust pipe gaskets after removing the exhaust pipe from the engine.
- When installing the exhaust system, loosely install all of the exhaust pipe fasteners. Always tighten the exhaust clamps first, then tighten the mounting fasteners. If you tighten the mounting fasteners first, the exhaust pipe may not seat properly.
- Always inspect the exhaust system for leaks after installation.

TORQUE VALUES

Exhaust pipe joint nut	20 N·m (2.0 kickoff, 14 lbf·ft)	
Muffler mounting bolt	22 N·m (2.2 kgf·m, 16 lbf·ft)	
Exhaust pipe mounting nut	22 N·m (2.2 kgf·m, 16 lbf·ft)	
Muffler band bolt	22 N·m (2.2 kgf·m, 16 lbf·ft)	
Grab rail mounting socket bolt	26 N·m (2.7 kgf·m, 20 lbf·ft)	
Front fender mounting bolt	12 N·m (1.2 kgf·m, 9 lbf·ft)	
Rearview mirror mounting nut	34 N·m (3.5 kgf·m, 25 lbf·ft)	
Rear turn signal unit mounting nut	4.9 N·m (0.50 kgf·m, 3.6 lbf·ft)	
Taillight mounting nut	6.9 N·m (0.70 kgf·m, 5.1 lbf·ft)	
Fuel valve nut	34 N·m (3.5 kgf·m, 25 lbf·ft)	
Fuel tank stay nut	12 N·m (1.2 kgf·m, 9 lbf·ft)	
Front brake hose clamp bolt	12 N·m (1.2 kgf·m, 9 lbf·ft)	'04 model: ALOC bolt; replace with a new one
Front brake hose clamp cap nut	12 N·m (1.2 kgf·m, 9 lbf·ft)	After '04 model:
Side cover socket bolt	4 N·m (0.4 kgf·m, 3 lbf·ft)	

TROUBLESHOOTING

Excessive exhaust noise

- Broken exhaust system
- Exhaust gas leak

Poor performance

- Deformed exhaust system
- Exhaust gas leak
- Clogged muffler

SEAT

REMOVAL/INSTALLATION

Unhook the seat with the ignition key.

Remove the seat backward while releasing the seat hooks from the frame hooks.

Install the seat, inserting the hooks into the frame hooks.

Push the seat forward, then down to lock it.

After installation, make sure that the seat is installed properly by moving the seat.

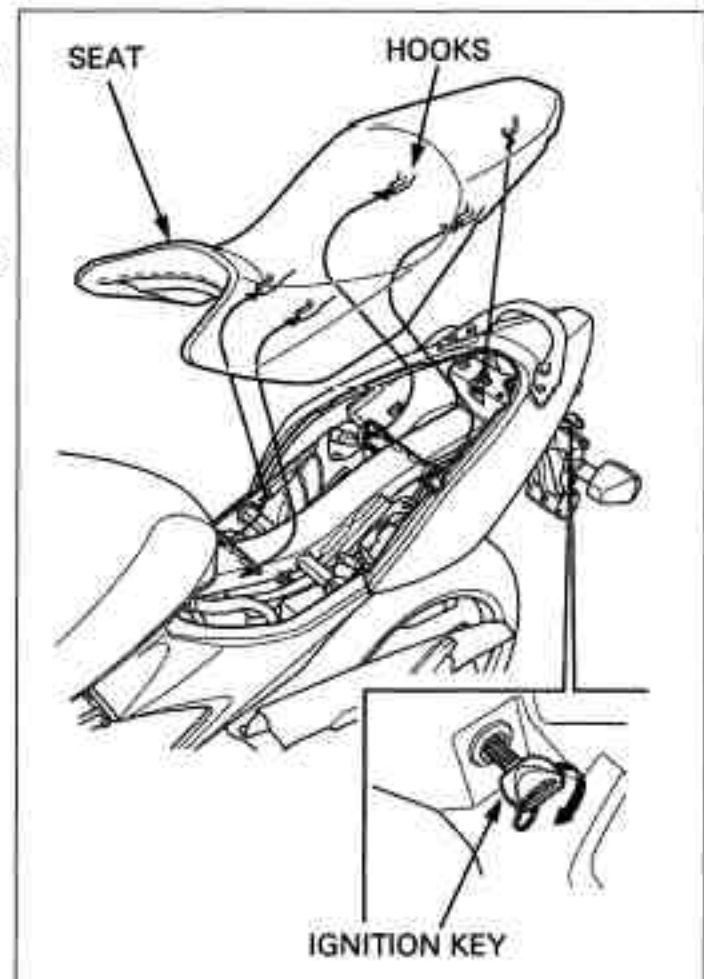

SIDE COVER

REMOVAL/INSTALLATION

Remove the seat (page 3-4).

Remove the socket bolt.

Release the rear tabs from the rear cowl and fuel tank grommets, then remove the side cover.

Install the side cover aligning the its tabs with the grommets in the rear cowl and fuel tank.

Install and tighten the socket bolt to the specified torque.

TORQUE: 4 N·m (0.4 kgf·m, 3 lbf·ft)

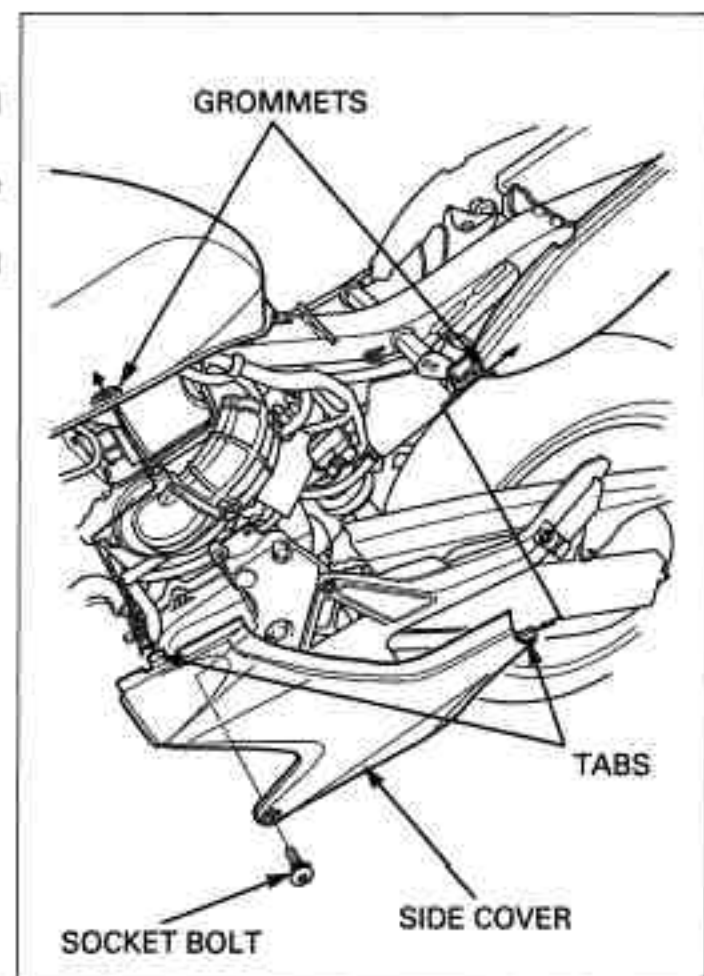

REAR COWL

REMOVAL

- Remove the seat (page 3-4).
- Remove the side cover (page 3-4).
- Remove the bolt caps.
- Remove the socket bolts and grab rail.

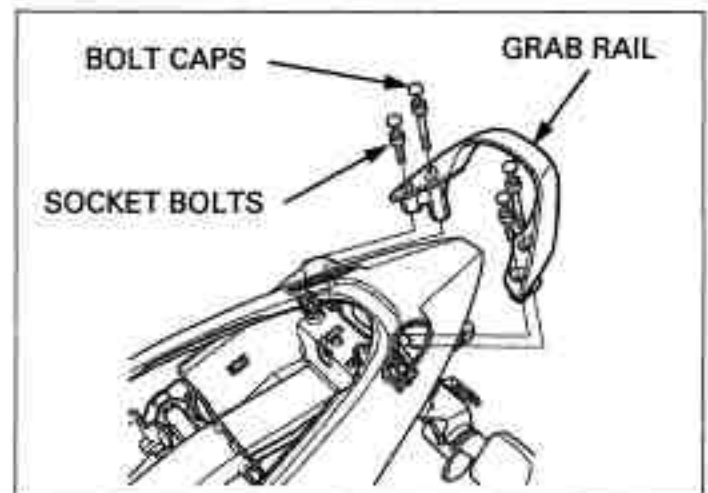

Disconnect the tail/brake light 3P (Natural) connector.

- Remove the flange bolts and bolts/washers.
- Carefully release the tabs of the rear cowl from the rear fender, then remove the rear cowl.

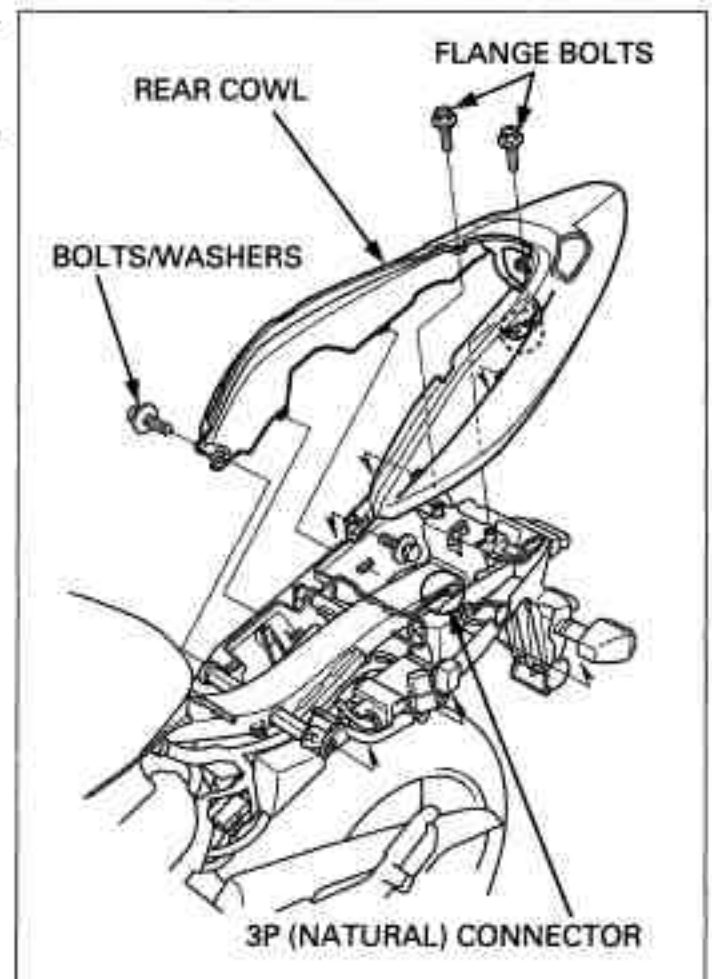

INSTALLATION

- Installation is in the reverse order of removal.
- Install the grab rail and mounting bolts.
- Tighten the mounting socket bolts to the specified torque.
- TORQUE: 26 N·m (2.7 kgf·m, 20 lbf·ft)**
- Install the bolt caps securely.

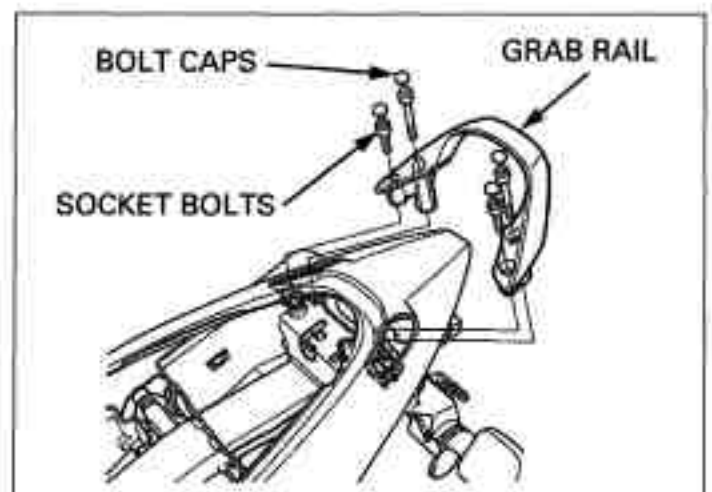

FUEL TANK

REMOVAL

Remove the seat (page 3-4).
Remove the side cover (page 3-4).
Turn the fuel valve OFF.
Remove the fuel tank stay bolt and nut.

'04 model: Disconnect the fuel valve vacuum hose from the 3-way joint.

After '04 model: Disconnect the fuel valve vacuum hose (from No.3 carburetor).

Disconnect the fuel hose from the fuel valve.

Swing the rear end of the fuel tank and disconnect the fuel tank drain hose and fuel tank breather hose.

Disconnect the fuel reserve sensor 2P (Natural) connector.

Be careful not to damage the No.1 carburetor vacuum chamber with the fuel valve.

Release the fuel tank from the mounting rubbers, then remove the fuel tank upward.

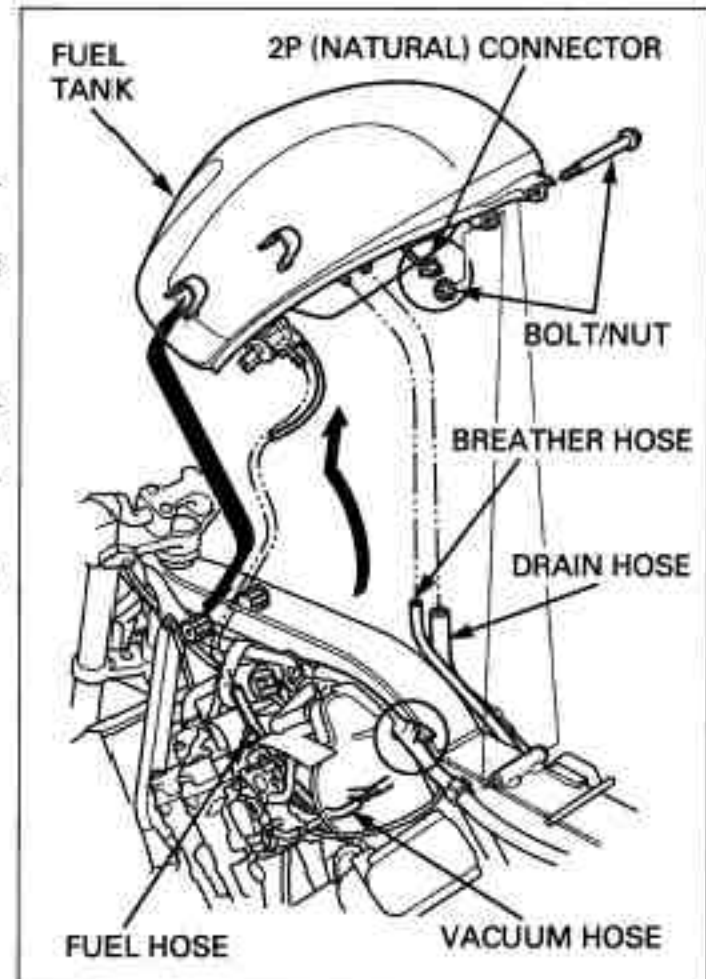

INSTALLATION

Make sure that the wire harness and hoses are routed properly (page 1-23).

Installation is in the reverse order of removal.

Tighten the fuel tank stay nut to the specified torque.

TORQUE: 12 N·m (1.2 kgf·m, 9 lbf·ft)

After installation, turn the fuel valve ON and make sure there are no fuel leaks.

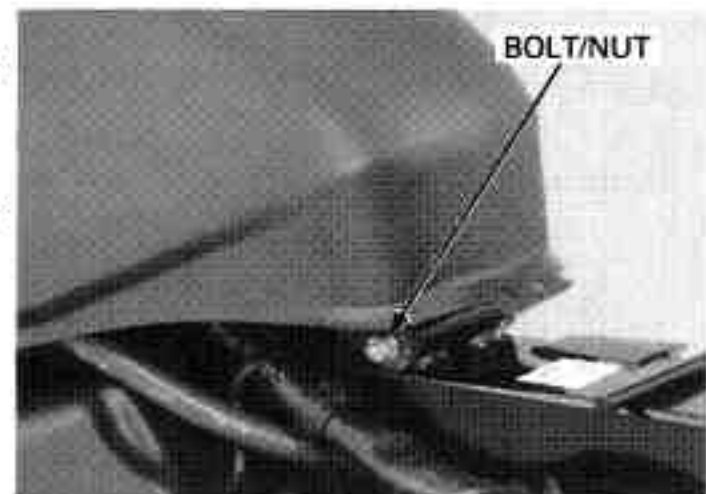

FRONT FENDER ('04 model)

REMOVAL/INSTALATION

Remove the front brake hose clamp bolts.
Remove the mounting bolts, front reflector and front fender.

Installation is in the reverse order of removal.
Install the front fender mounting bolts and new front brake hose clamp bolts.

Tighten the front fender mounting bolts to the specified torque.

TORQUE: 12 N·m (1.2 kgf·m, 9 lbf·ft)

Tighten the front brake hose clamp bolts to the specified torque.

TORQUE: 12 N·m (1.2 kgf·m, 9 lbf·ft)

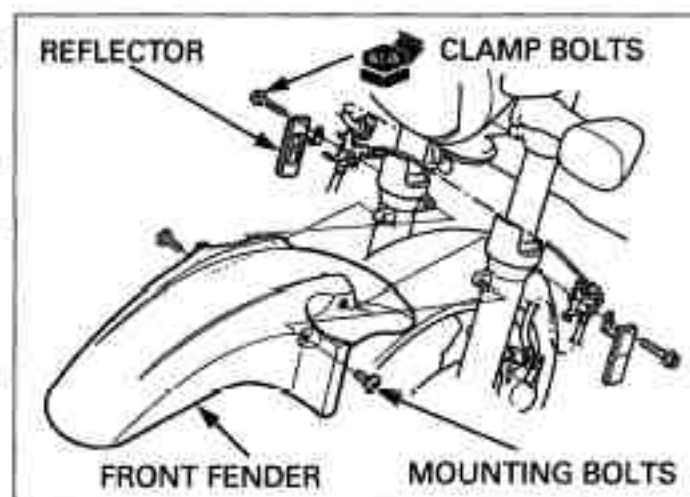

FRONT FENDER (After '04 model)

REMOVAL/INSTALLATION

Be careful not to scratch the front fender when removing it between the front forks.

Remove the front brake hose clamp cap nuts.

Remove the mounting bolts, front reflectors and front fender.

Install the front fender mounting bolts, the front reflectors and front brake hose clamp cap nuts.

Tighten the front fender mounting bolts to the specified torque.

TORQUE: 12 N·m (1.2 kgf·m, 9 lbf·ft)

Tighten the front brake hose clamp cap nuts to the specified torque.

TORQUE: 12 N·m (1.2 kgf·m, 9 lbf·ft)

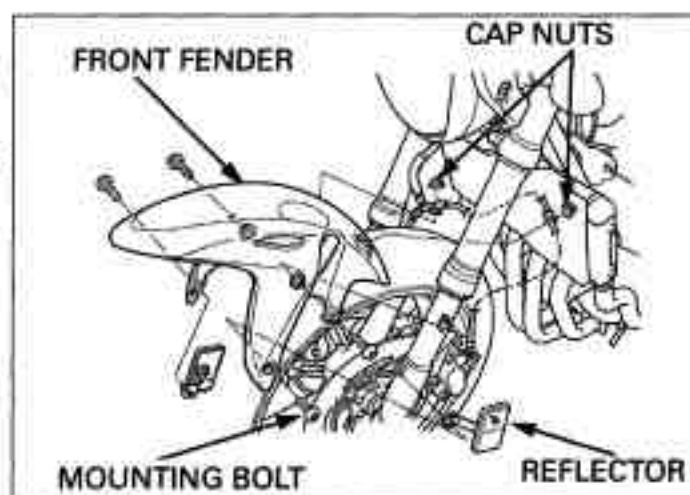

REAR FENDER

REMOVAL/INSTALLATION

Remove the following:

- Rear cowl (page 3-5)
- Muffler (page 3-9)
- ICM (page 18-12)
- Turn signal relay (page 20-31)
- Headlight relay (page 20-31)

Disconnect the license light connectors and rear turn signal connectors.

Disconnect the seat lock cable from the seat lock key cylinder.

Remove the bolts and clamp.

Release the grooves of the rear fender from the frame braces and remove the rear fender.

Installation is in the reverse order or removal.

While installing the rear fender, route the wire harness properly (page 1-23).

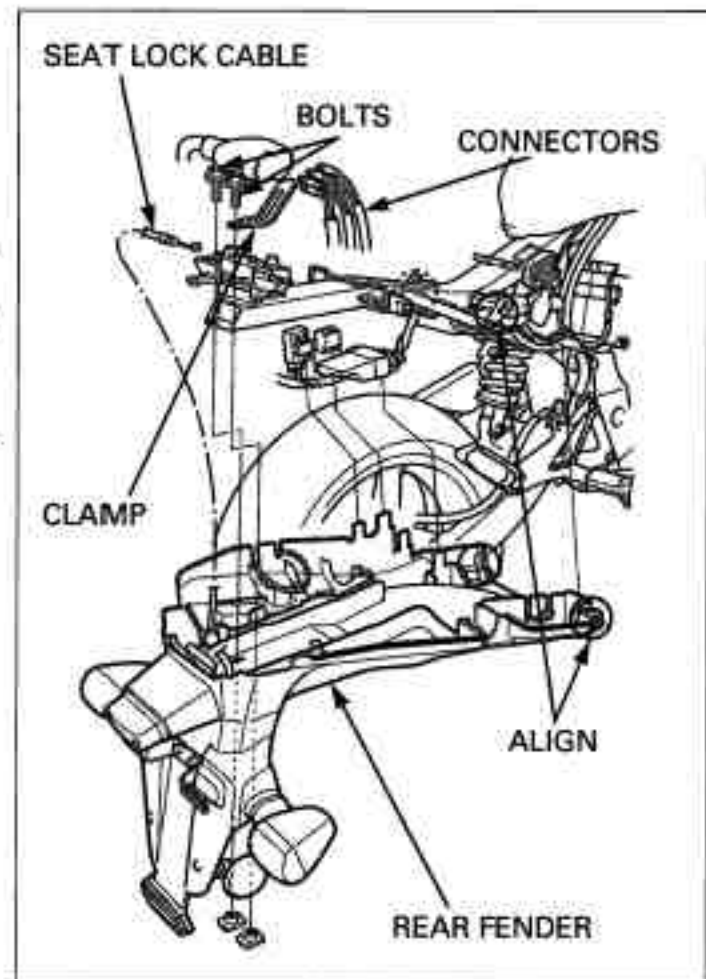

METER VISOR (After '04 model)

Loosen the headlight case bolts.

Remove the four socket bolts and meter visor.

Install the meter visor in the reverse order of removal.

Adjust the headlight beam vertically (page 4-30).

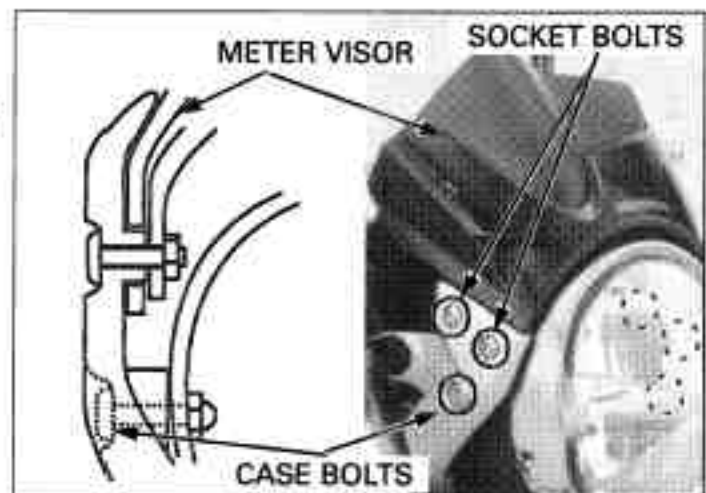

MUFFLER/EXHAUST PIPE

MUFFLER REMOVAL/INSTALLATION

Remove the rear cowl (page 3-5).

Loosen the Muffler band bolt.

Remove the muffler mounting bolt, washer and collar.

Remove the muffler and gasket.

Installation is in the reverse order of removal.

Tighten the muffler mounting bolt to the specified torque.

TORQUE: 22 N-m (2.2 kgf-m, 16 lbf-ft)

Tighten the muffler band bolt to the specified torque.

TORQUE: 22 N-m (2.2 kgf-m, 16 lbf-ft)

Always replace the gasket with a new one.

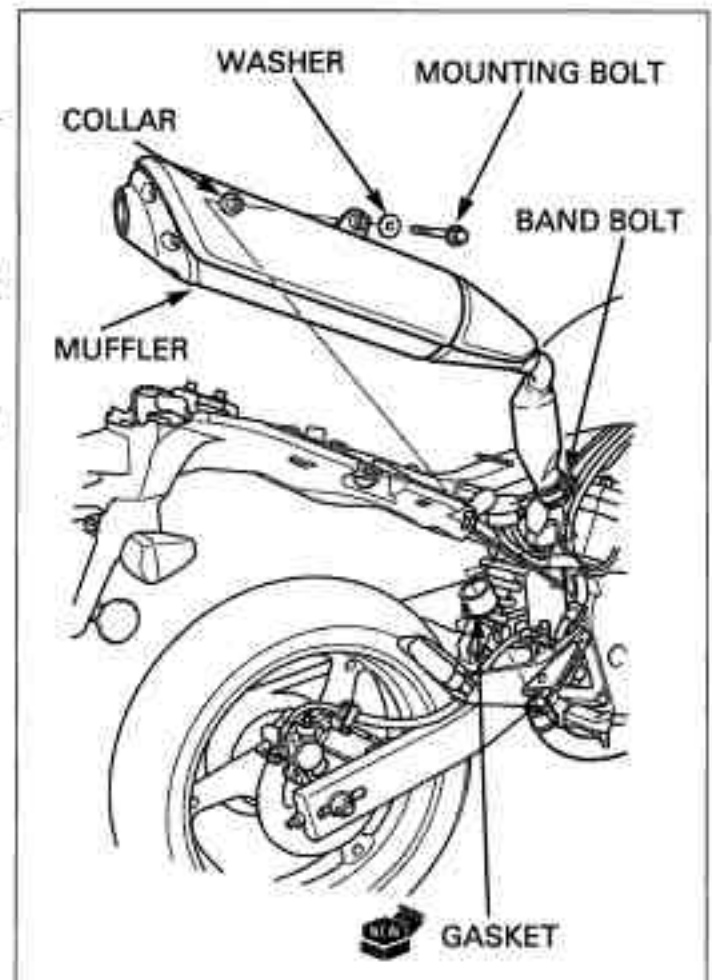

MUFFLER DISASSEMBLY/ASSEMBLY

Remove the socket bolt, collar and rubber mount. Release the grommet tabs from the hooks on the muffler and the hooks from the grommet tabs on the front protector, then remove the rear protector.

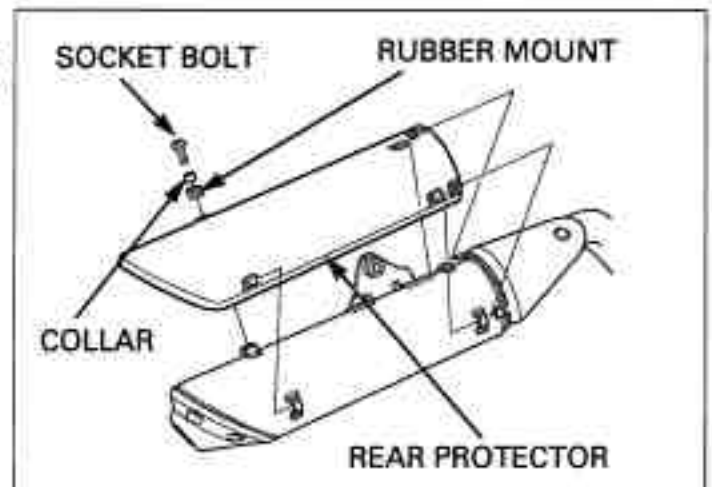

Remove the socket bolt and front protector.

Assembly is in the reverse order of disassembly.

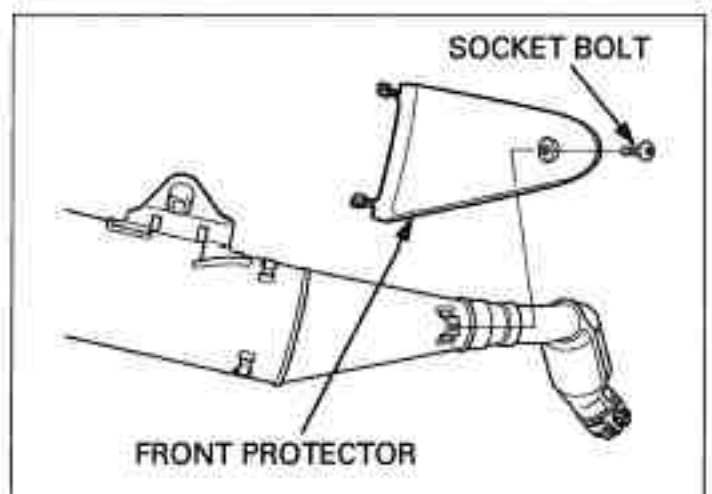

FRAME/BODY PANELS/EXHAUST SYSTEM

EXHAUST PIPE REMOVAL

Remove the muffler (page 3-9).

For ease of exhaust pipe removal, remove the radiator mounting bolts and release the radiator grommet from the tab on the frame.

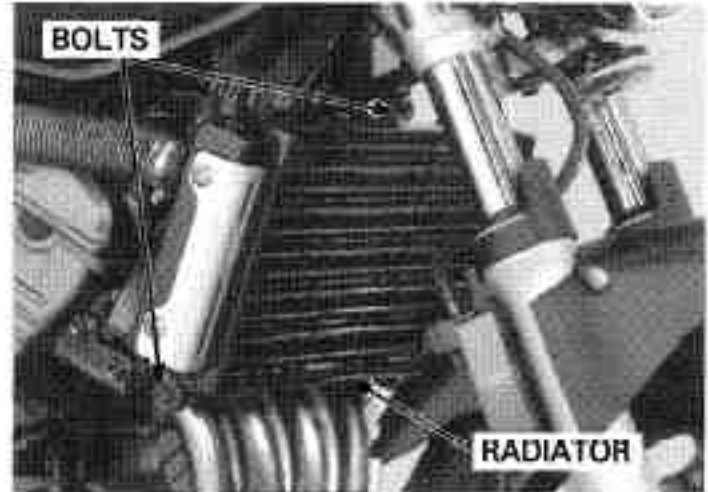

Remove the exhaust pipe joint nuts.

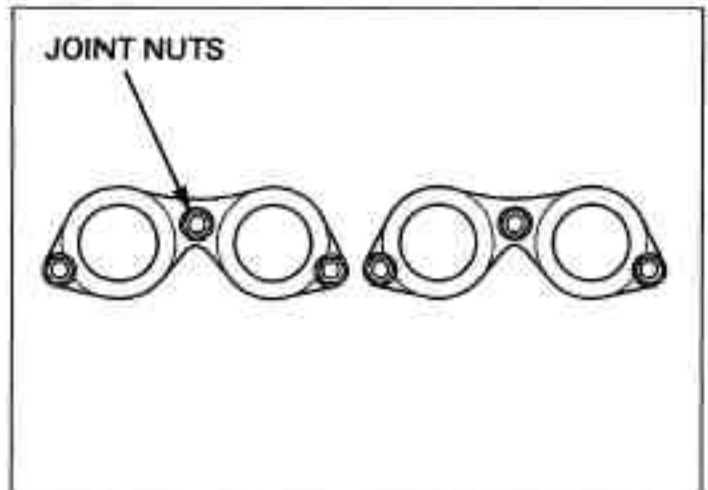

Remove the exhaust pipe mounting nut, washer, collar and bolt.
Remove the exhaust pipe and gaskets.

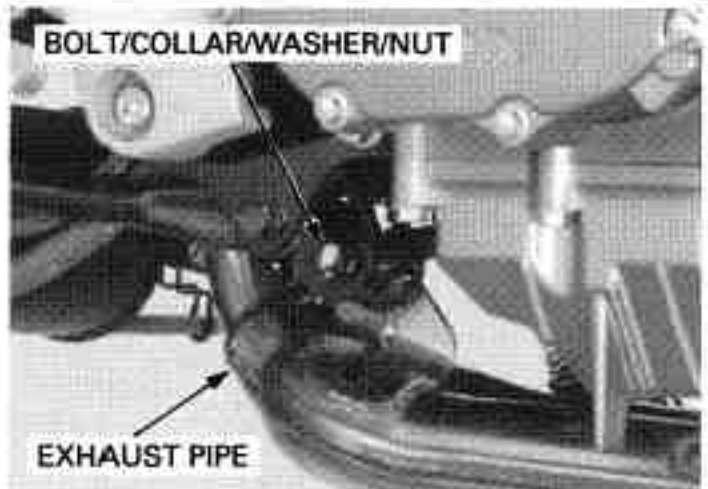

EXHAUST PIPE INSTALLATION

Always replace the gaskets with new ones.

Install the exhaust pipe and new gaskets to the cylinder head.

Temporarily install the exhaust pipe joint nuts, exhaust pipe mounting bolt, collar, washer and nut.

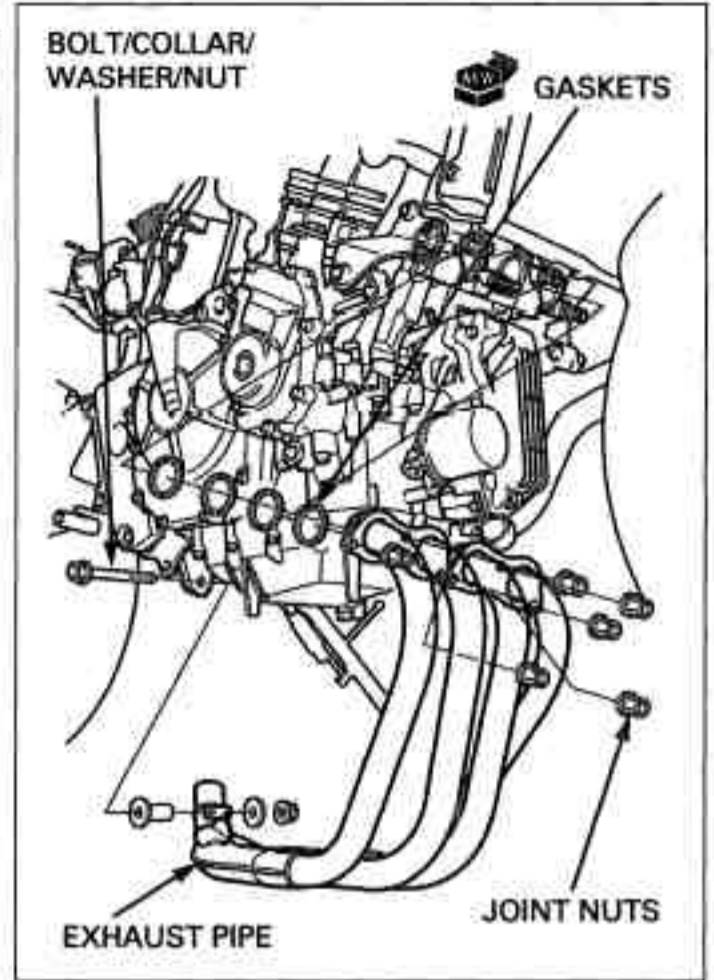

Tighten the exhaust pipe joint nuts in numerical order shown in the illustration.

First tighten the exhaust pipe joint nuts to the specified torque.

TORQUE: 20 N·m (2.0 kgf·m, 14 lbf·ft)

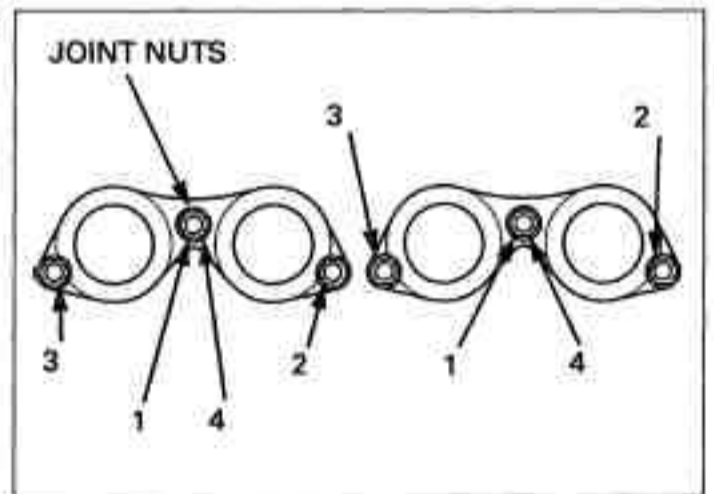

Tighten the exhaust pipe mounting nut to the specified torque.

TORQUE: 22 N·m (2.2 kgf·m, 16 lbf·ft)

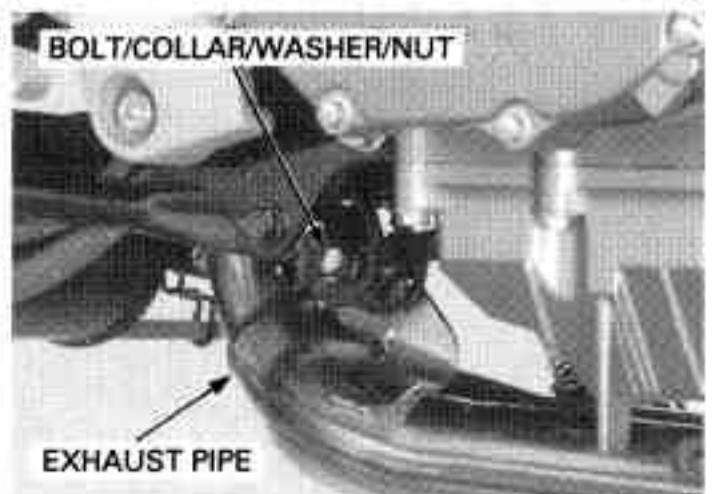

FRAME/BODY PANELS/EXHAUST SYSTEM

Align the grommet on the radiator with the tab on the frame.

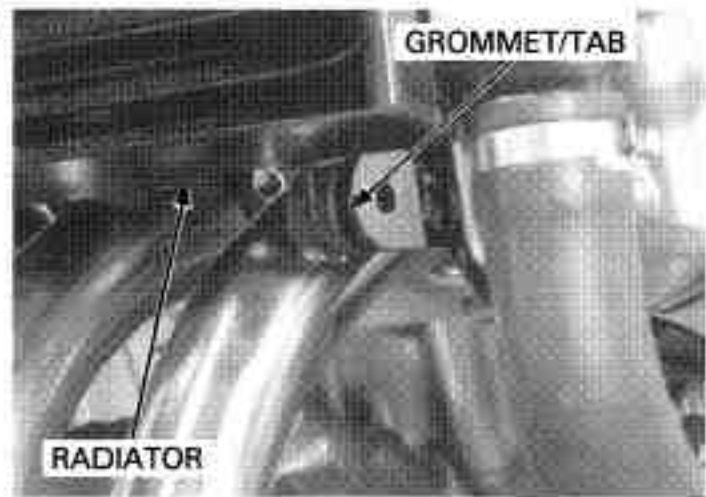

Install the radiator and tighten the mounting bolts.
Install the muffler (page 3-9).

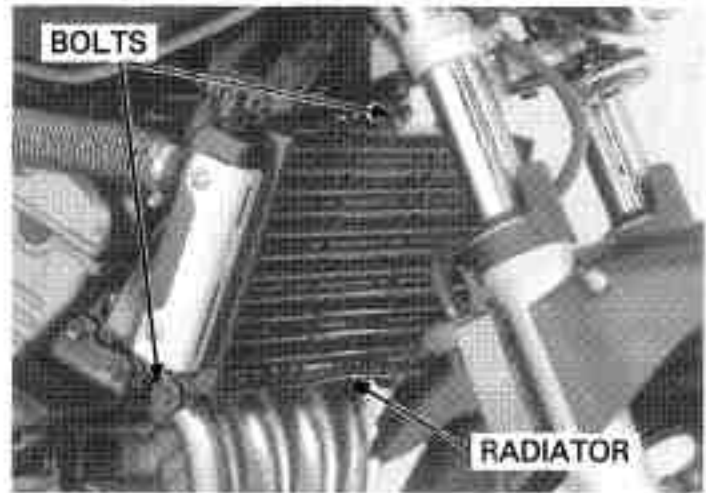

SERVICE INFORMATION	4-2	SECONDARY AIR SUPPLY SYSTEM	4-22
MAINTENANCE SCHEDULE	4-4	EVAPORATIVE EMISSION CONTROL SYSTEM	4-23
FUEL LINE	4-5	DRIVE CHAIN	4-23
THROTTLE OPERATION	4-5	BRAKE FLUID	4-27
CARBURETOR CHOKE	4-6	BRAKE PAD WEAR	4-28
AIR CLEANER	4-6	BRAKE SYSTEM	4-29
SPARK PLUG	4-7	BRAKE LIGHT SWITCH	4-29
VALVE CLEARANCE	4-9	HEADLIGHT AIM	4-30
ENGINE OIL/OIL FILTER	4-14	CLUTCH SYSTEM	4-30
CARBURETOR SYNCHRONIZATION ('04 model)	4-17	SIDE STAND	4-31
CARBURETOR SYNCHRONIZATION (After '04 model)	4-19	SUSPENSION	4-31
ENGINE IDLE SPEED	4-21	NUTS, BOLTS, FASTENERS	4-32
RADIATOR COOLANT	4-21	WHEELS/TIRES	4-33
COOLING SYSTEM	4-21	STEERING HEAD BEARINGS	4-33

MAINTENANCE

SERVICE INFORMATION

GENERAL

- Place the motorcycle on level ground before starting any work.
- Gasoline is extremely flammable and is explosive under certain conditions.
- Work in a well ventilated area. Smoking or allowing flames or sparks in the work area or where the gasoline is stored can cause a fire or explosion.
- The exhaust contains poisonous carbon monoxide gas that may cause loss of consciousness and may lead to death. Run the engine in an open area or with an exhaust evacuation system in and enclosed area.

SPECIFICATIONS

ITEM		SPECIFICATIONS	
Throttle grip free play		2 – 6 mm (1/16 – 1/4 in)	
Spark plug	NGK	CR9EH-9	
	DENSO	U27FER9	
Spark plug gap		0.80 – 0.90 mm (0.031 – 0.035 in)	
Valve clear- ance	IN	0.16 ± 0.03 mm (0.006 ± 0.001 in)	
	EX	0.22 ± 0.03 mm (0.009 ± 0.001 in)	
Engine oil capacity	After draining	3.5 liter (3.7 US qt, 3.1 Imp qt)	
	After oil filter change	3.8 liter (4.0 US qt, 3.3 Imp qt)	
Recommended engine oil		Pro Honda GN4 or HP4 (Without molybdenum additives) 4- stroke oil or equivalent motor oil API service classification SG or Higher JASO T 903 standard: MA Viscosity: SAE 10W-40	
Engine idle speed		1,400 ± 100 rpm	
Drive chain slack		30 – 40 mm (1.2 – 1.6 in)	
Recommended brake fluid		DOT 4	
Clutch lever free play		10 – 20 mm (3/8 – 13/16 in)	
Tire size	Front	120/70 ZR 17M/C (58W)	
	Rear	180/55 ZR 17M/C (73W)	
Tire brand	Bridgestone	Front	BT-56F RADIAL N
		Rear	BT-56R RADIAL G
	Michelin	Front	Pilot ROAD S
		Rear	Pilot ROAD S
Tire air pres- sure	Driver only	Front	250 kPa (2.50 kgf/cm ² , 36 psi)
		Rear	290 kPa (2.90 kgf/cm ² , 42 psi)
	Driver and passenger	Front	250 kPa (2.50 kgf/cm ² , 36 psi)
		Rear	290 kPa (2.90 kgf/cm ² , 42 psi)
Minimum tire tread depth	Front	1.5 mm (0.06 in)	
	Rear	2.0 mm (0.08 in)	

TORQUE VALUES

Spark plug	12 N·m (1.2 kgf·m, 9 lbf·ft)	'04 model
Spark plug	18 N·m (1.8 kgf·m, 13 lbf·ft)	After '04 model
Timing hole cap	18 N·m (1.8 kgf·m, 13 lbf·ft)	Apply grease to the threads
Engine oil drain bolt	29 N·m (3.0 kgf·m, 22 lbf·ft)	
Engine oil filter cartridge	25 N·m (2.5 kgf·m, 18 lbf·ft)	Apply oil to the threads and flange surface
Cylinder head cover bolt	10 N·m (1.0 kgf·m, 7 lbf·ft)	
Camshaft holder flange bolt	12 N·m (1.2 kgf·m, 9 lbf·ft)	Apply oil to the threads and flange surface
Rear axle nut	88 N·m (9.0 kgf·m, 65 lbf·ft)	U-nut
Drive chain adjuster lock nut	21 N·m (2.1 kgf·m, 15 lbf·ft)	

TOOLS

Oil filter wrench
07HAA-PJ70101

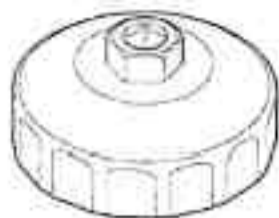

or 07HAA-PJ70100 (U.S.A. only)

Drive chain tool set
07HMH-MR10103

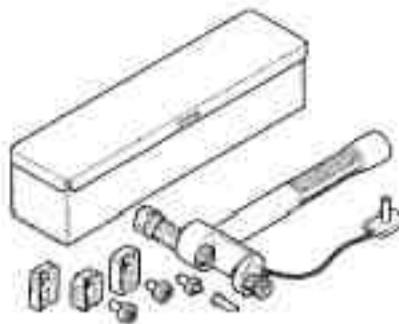

or 07HMH-MR1010C (U.S.A. only)

Tensioner stopper
07NMG-MY90101



Not available in U.S.A.

Vacuum gauge set
07LMJ-001000A (U.S.A. only)

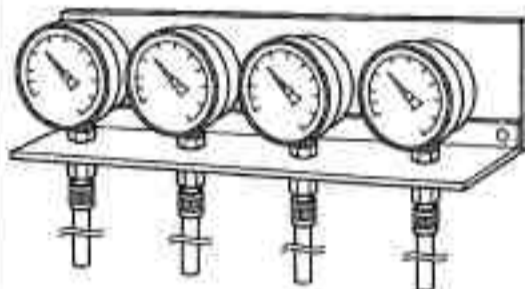

or 07LMJ-001000B (U.S.A. only)

MAINTENANCE

MAINTENANCE SCHEDULE

Perform the Pre-ride inspection in the Owner's Manual at each scheduled maintenance period.

I: Inspect and Clean, Adjust, Lubricate or Replace if necessary. C: Clean. R: Replace. A: Adjust. L: Lubricate.

The following items require some mechanical knowledge. Certain items (particularly those marked * and **) may require more technical information and tools. Consult their authorized Honda dealer.

ITEMS	FREQUENCY	NOTE ↓	ODOMETER READING (NOTE 1)								REFER TO PAGE		
			X1,000 mi	0.6	4	8	12	16	20	24			
			X1,000 km	1.0	6.4	12.8	19.2	25.6	32.0	38.4			
EMISSION RELATED ITEMS	* FUEL LINE					I			I		I	4-5	
	* THROTTLE OPERATION					I			I		I	4-5	
	* CHOKE OPERATION					I			I		I	4-6	
	AIR CLEANER	NOTE2						I			I	4-6	
	SPARK PLUG				I	R	I	R	I	R		4-7	
	* VALVE CLEARANCE								I			4-9	
	ENGINE OIL	'04 model		R		R		R		R		4-14	
		After '04 model		INITIAL = 600 mi (1,000 km) or 1 month: R REGULAR = Every 8,000 mi (12,800 km) or 12 months: R									
	ENGINE OIL FILTER			R		R		R		R		4-14	
	* CARBURETOR SYNCHRONIZATION						I			I		I	4-17
	* ENGINE IDLE SPEED			I	I	I	I	I	I	I	I		4-21
	RADIATOR COOLANT	NOTE3					I			I		R	4-21
	* COOLING SYSTEM						I			I		I	4-21
* SECONDARY AIR SUPPLY SYSTEM						I			I		I	4-22	
* EVAPORATIVE EMISSION CONTROL SYSTEM	NOTE 4						I				I	4-23	
DRIVE CHAIN			Every 500 mi (800 km) I, L								4-23		
BRAKE FLUID	NOTE3				I	I	R	I	I		R	4-27	
BRAKE PAD WEAR					I	I	I	I	I	I	I	4-28	
BRAKE SYSTEM			I			I			I		I	4-29	
* BRAKE LIGHT SWITCH						I			I		I	4-29	
* HEADLIGHT AIM						I			I		I	4-30	
CLUTCH SYSTEM			I	I	I	I	I	I	I	I	I	4-30	
SIDE STAND						I			I		I	4-31	
* SUSPENSION						I			I		I	4-31	
* NUTS, BOLTS, FASTENERS			I			I			I		I	4-32	
** WHEELS/TIRES						I			I		I	4-33	
** STEERING HEAD BEARINGS			I			I			I		I	4-33	

* Should be serviced by an authorized Honda dealer, unless the owner has proper tools and service data and is mechanically qualified.

** In the interest of safety, we recommended these items be serviced only by an authorized Honda dealer.

NOTES:

- At higher odometer readings, repeat at the frequency interval established here.
- Service more frequently if the motorcycle is ridden in unusually wet or dusty areas.
- Replace every 2 years, or at indicated odometer interval, whichever comes first. Replacement requires mechanical skill.
- California type only.

FUEL LINE

Check the fuel lines for deterioration, damage or leakage.
 Replace the fuel line if necessary.
 Also check the fuel line fittings for leakage.

Check the fuel valve vacuum hose for damage or pinched hose.



THROTTLE OPERATION

Check for smooth throttle grip full opening and automatic full closing in all steering positions.
 Check the throttle cables and replace them if they are deteriorated, kinked or damaged.
 Lubricate the throttle cables, if throttle operation is not smooth.

Measure the free play at the throttle grip flange.

FREE PLAY: 2 – 6 mm (1/16 – 1/4 in)

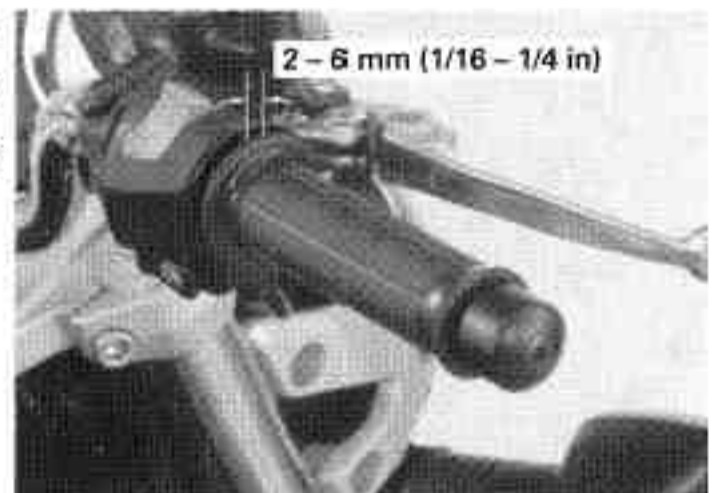

Throttle grip free play can be adjusted at either end of the throttle cable.

Minor adjustments are made with the upper adjuster.
 Adjust the free play by loosening the lock nut and turning the adjuster.

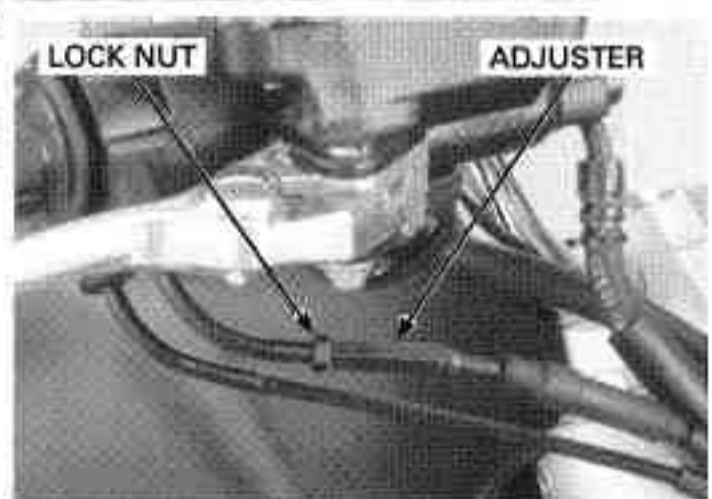

Major adjustments are made with the lower adjuster.

Adjust the free play by loosening the lock nut and turning the adjuster.
 After adjustment, tighten the lock nut securely.
 Recheck the throttle operation.
 Replace any damaged parts, if necessary.

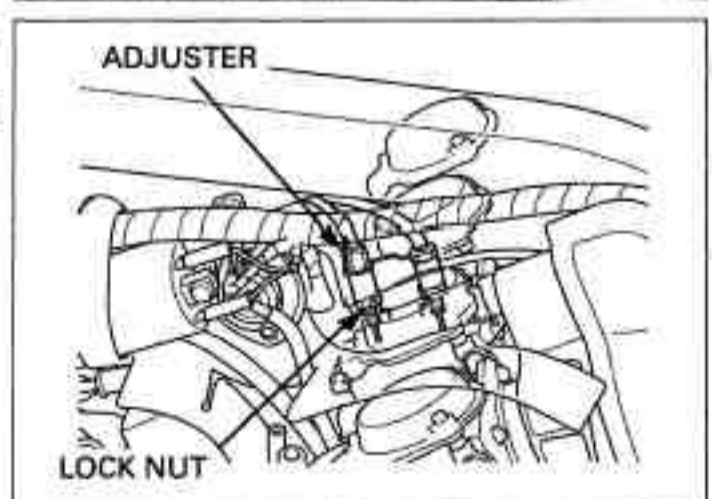

MAINTENANCE

CARBURETOR CHOKE

Check for smooth operation of the choke lever.

Lubricate the choke cable if the operation is not smooth.



AIR CLEANER

Remove the left side cover (page 3-4).

Remove the screws and air cleaner housing cover.

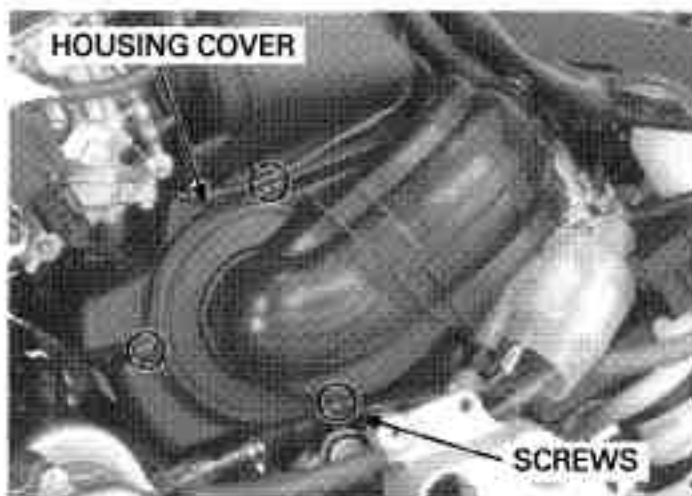

Remove and inspect the air cleaner element.

Clean the air cleaner element from the carburetor side by compressed air.

Install the removed parts in the reverse order of removal.

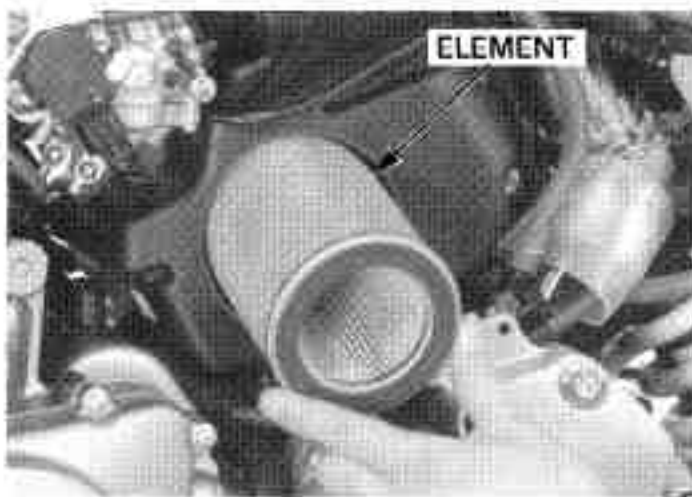

SPARK PLUG

REMOVAL

Be careful not to damage the radiator fins.

Remove the radiator mounting bolts, then release the grommet of the radiator from the tab on the frame.

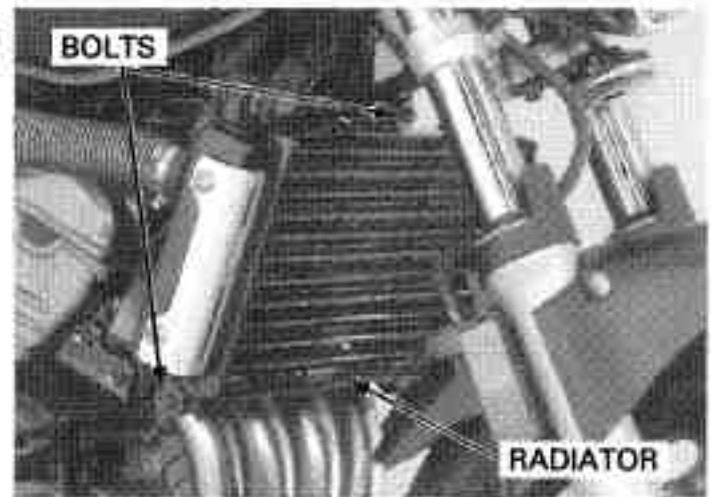

Remove the seat (page 3-4).
Remove the side cover (page 3-4).

Remove the fuel tank stay nut/bolt, then release the fuel tank hooks from the frame grommets. Place the fuel tank hooks onto the frame grommets.

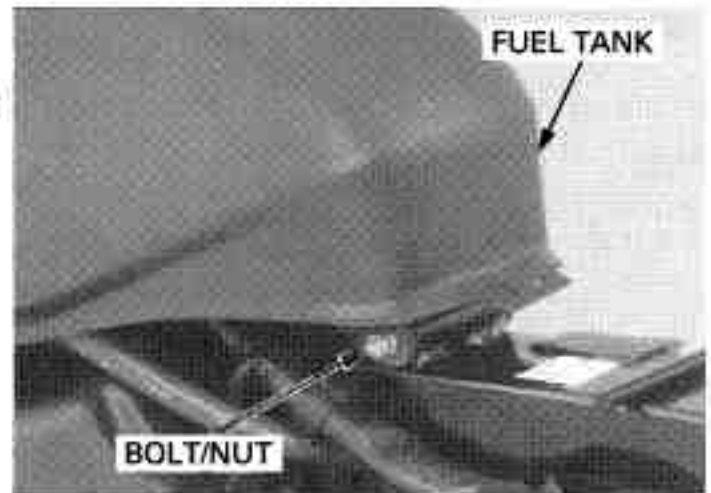

Clean around the spark plug bases with compressed air before removing, and be sure that no debris is allowed to enter the combustion chamber.

Disconnect the spark plug caps from the spark plugs.

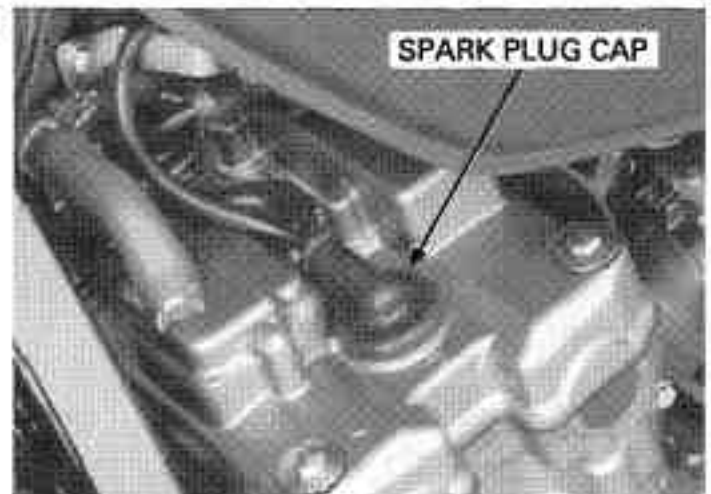

Remove the spark plug using the equipped spark plug wrench or an equivalent tool.

Inspect or replace as described in the maintenance schedule (page 4-4).

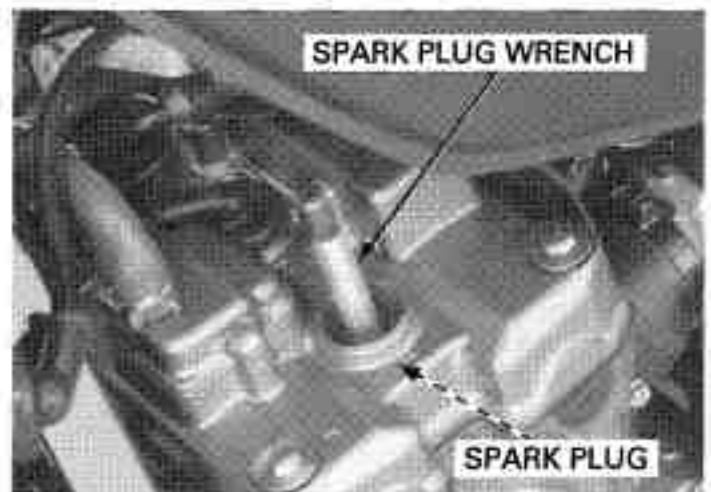

INSPECTION

Check the following and replace if necessary (recommended spark plug: page 4-2)

- Insulator for damage
- Electrodes for wear
- Burning condition, coloration

If the electrodes is contaminated with accumulated objects or dirt, replace the spark plug.

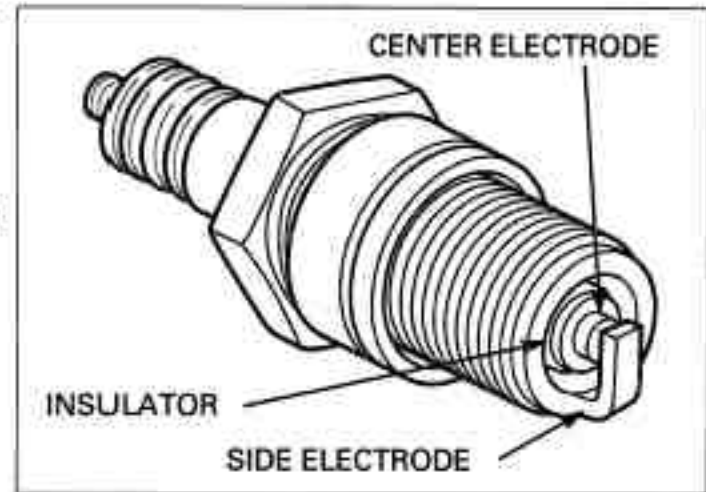

REUSING A SPARK PLUG

Clean the spark plug electrodes with a wire brush or special plug cleaner.

Check the gap between the center and side electrodes with a wire-type feeler gauge.

If necessary, adjust the gap by bending the side electrodes carefully.

SPARK PLUG GAP: 0.80 – 0.90 mm (0.031 – 0.035 in)

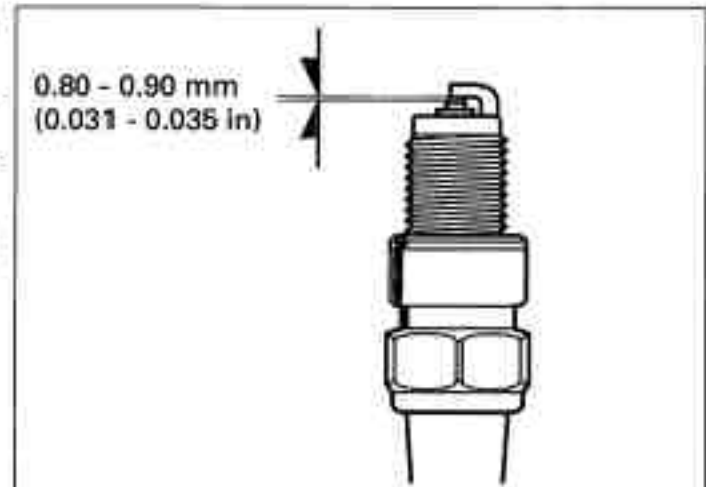

Reinstall the spark plugs in the cylinder head and hand tighten, then torque to the specification.

TORQUE:

'04 model 12 N·m (1.2 kgf·m, 9 lbf·ft)

After '04 model: 18 N·m (1.8 kgf·m, 13 lbf·ft)

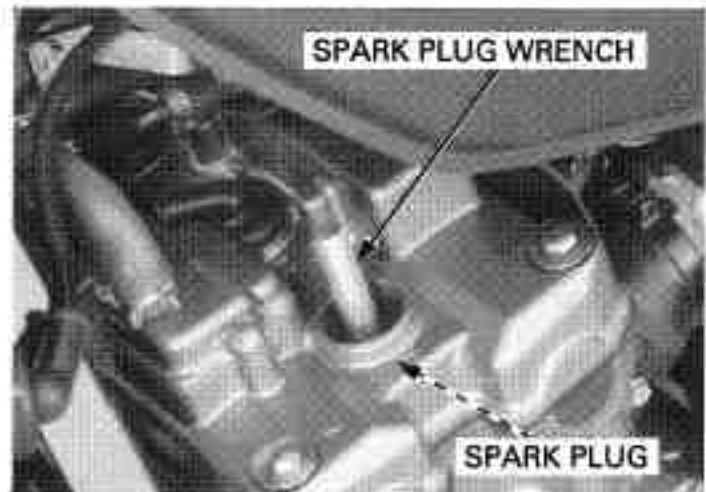

REPLACING A SPARK PLUG

Set the plug gap to specification with a wire-type feeler gauge (page 4-8).

Do not overtighten the plug.

Install and hand tighten the new spark plug, then tighten it about 1/2 turn after the sealing washer contacts the seat of the plug hole.

Install the spark plug caps.

Install the fuel tank (page 3-6).

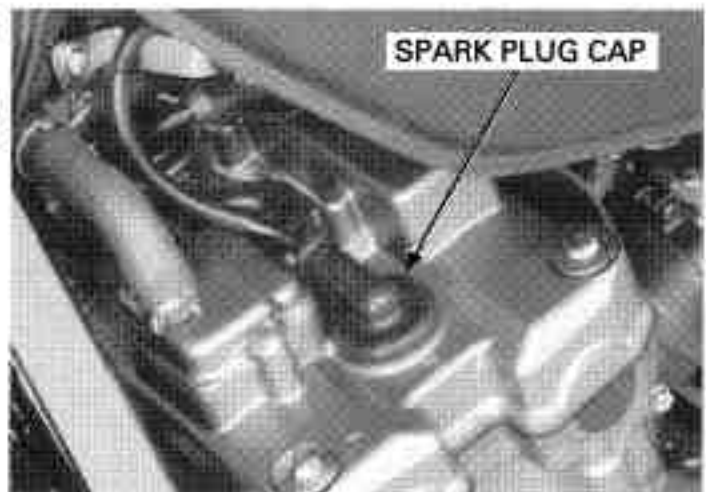

Align the radiator grommet with the tab on the frame.

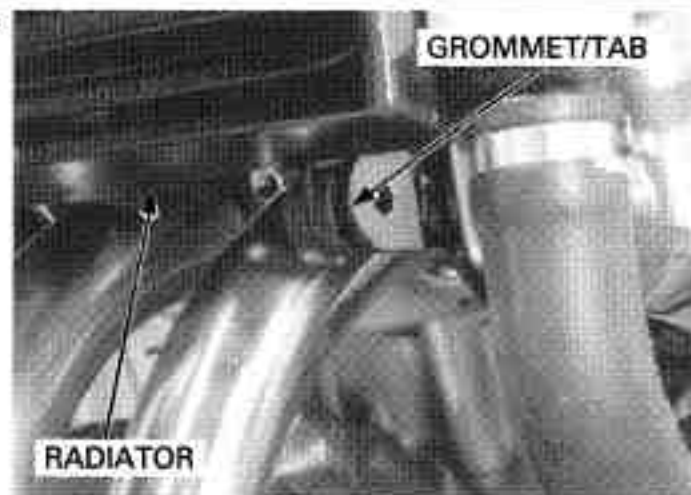

Install the radiator and tighten the bolts securely.

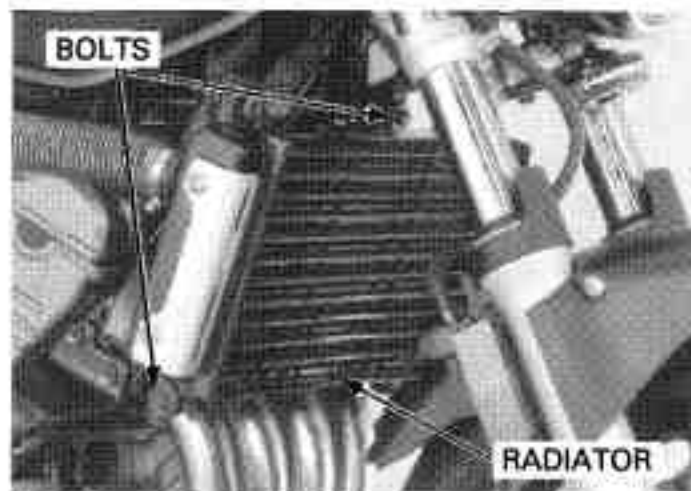

VALVE CLEARANCE

Inspect and adjust the valve clearance while the engine is cold (below 35°C/ 95°F)

INSPECTION

Remove the cylinder head cover (page 9-6).

Remove the cam chain tensioner lifter sealing bolt and sealing washer.

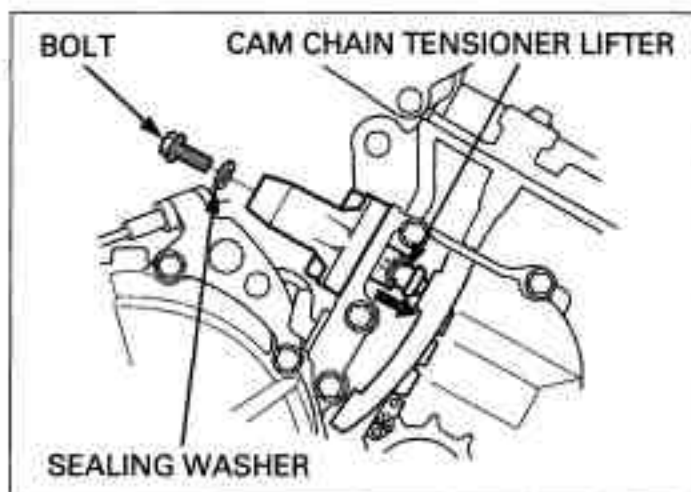

Failure to release the cam chain tensioner will result in inaccurate valve clearance reading.

Turn the cam chain tensioner lifter shaft fully and secure it using the special tool.

TOOL:
Tensioner stopper **07NMG-MY90101**
 (Not available in U.S.A.)

This tool can easily be made from a thin (1 mm thickness) piece of steel (page 9-7).

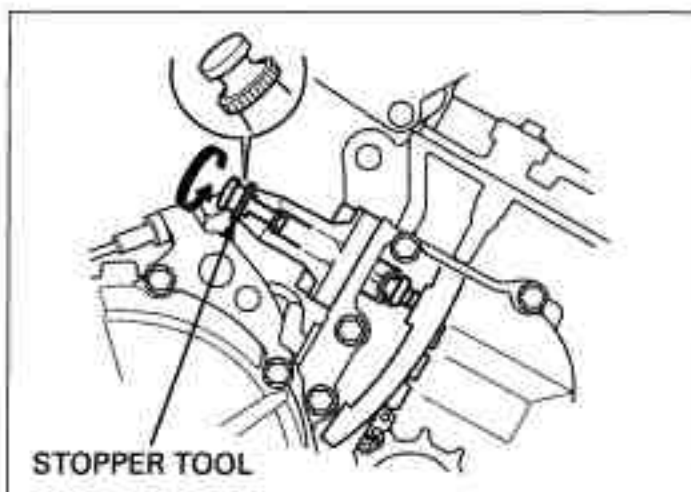

MAINTENANCE

Remove the timing hole cap and O-ring.

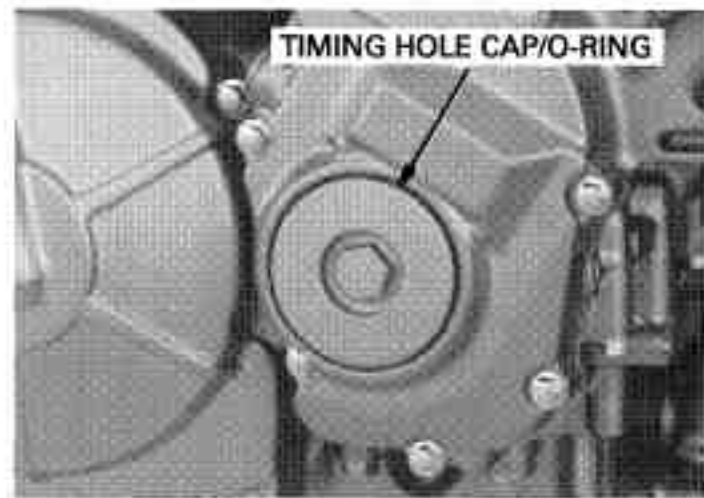

Turn the crankshaft clockwise, align the "T" mark on the ignition pulse generator rotor with the index mark on the ignition pulse generator rotor cover.

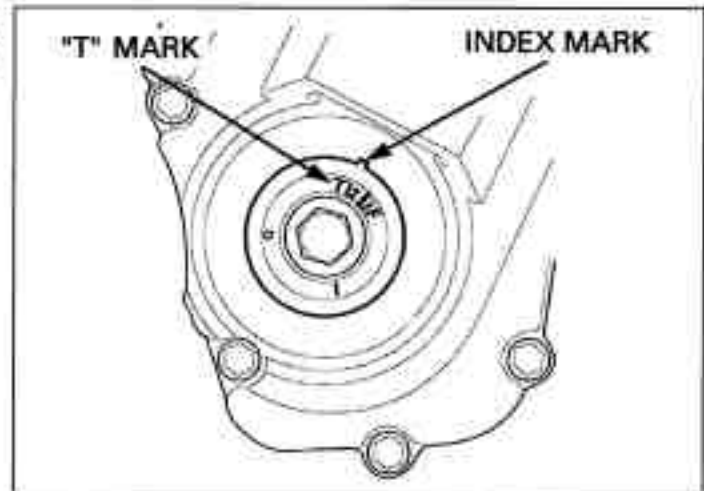

The timing marks ("IN" and "EX") on the cam sprockets must be flush with the cylinder head surface and facing outward as shown.

If the timing marks on the cam sprocket facing inward, turn the crankshaft clockwise one full turn (360°) and realign the timing marks with the cylinder head surface so they are facing outward.

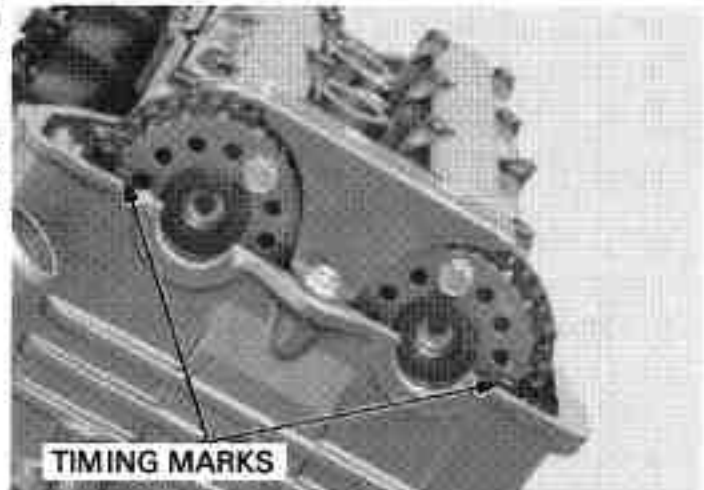

Insert the feeler gauge between the valve lifter and the cam lobe.



Record the clearance for each valve for reference in shim selection if adjustment is required.

Check the valve clearance for the No.1 and No.3 cylinder intake valves using a feeler gauge.

VALVE CLEARANCE:
IN: 0.16 ± 0.03 mm (0.006 ± 0.001 in)

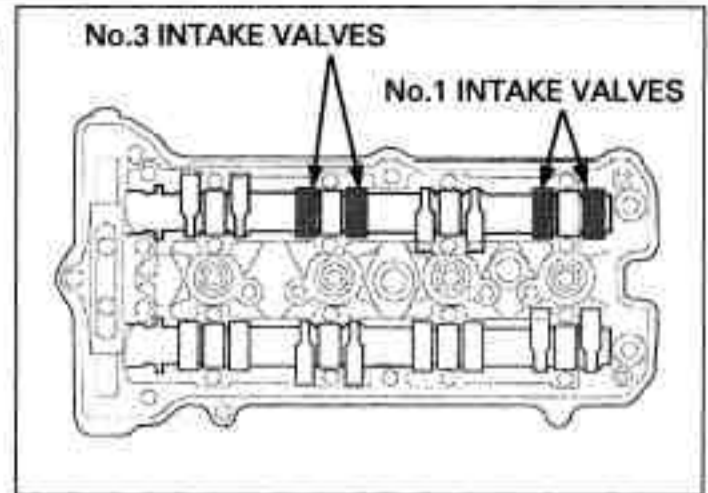

Turn the crankshaft clockwise 1/2 turn (180°), align the index line on the ignition pulse generator rotor so that it is facing up as shown.

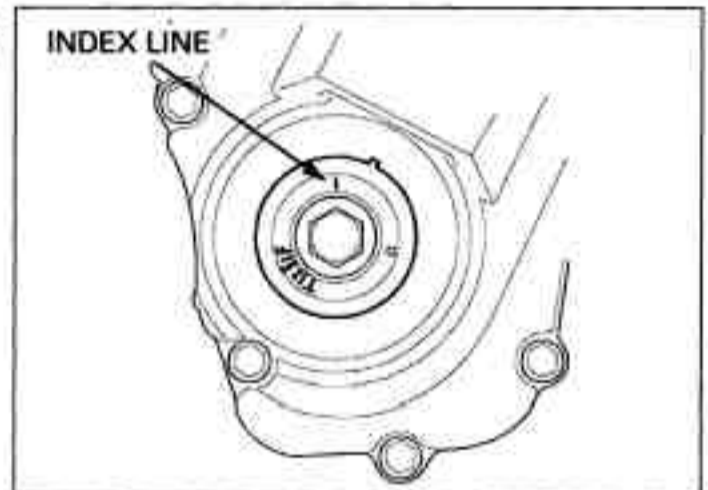

Record the clearance for each valve for reference in shim selection if adjustment is required.

Check the valve clearance for the No.2 and No.4 cylinder exhaust valves using a feeler gauge.

VALVE CLEARANCE:
EX: 0.22 ± 0.03 mm (0.009 ± 0.001 in)

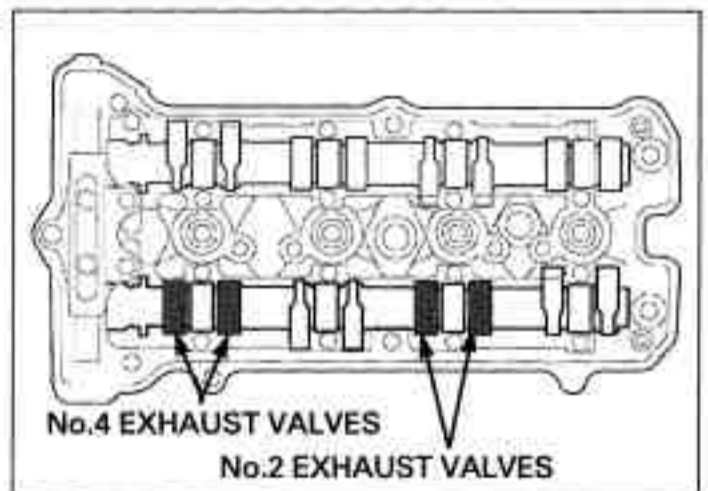

Turn the crankshaft clockwise 1/2 turn (180°), align the "T" mark on the ignition pulse generator rotor with the index mark on the right crankcase cover.

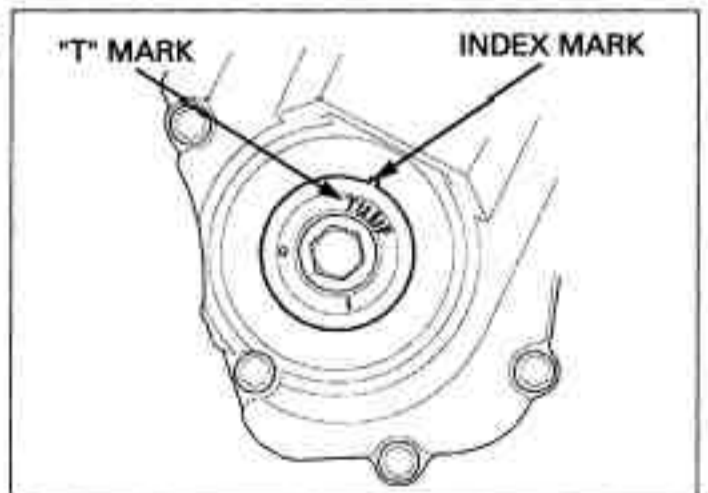

MAINTENANCE

Record the clearance for each valve for reference in shim selection if adjustment is required.

Check the valve clearance for the No.2 and No.4 cylinder intake valves using feeler gauge.

VALVE CLEARANCE:

IN: 0.16 ± 0.03 mm (0.006 ± 0.001 in)

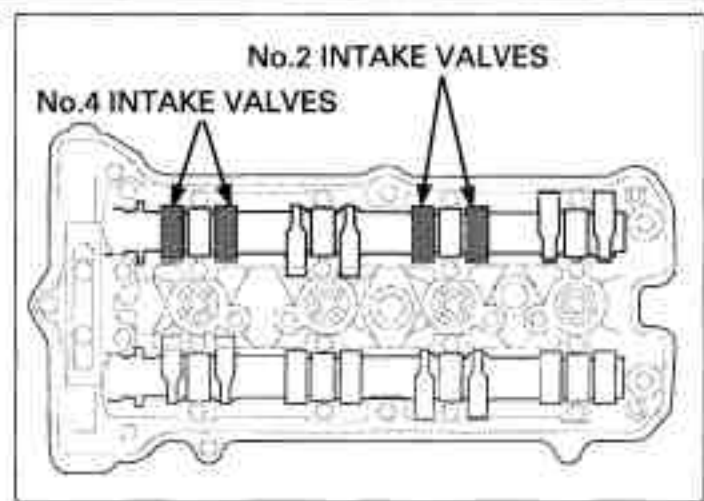

Turn the crankshaft clockwise 1/2 turn (180°), align the index line on the ignition pulse generator rotor so that it is facing up as shown.

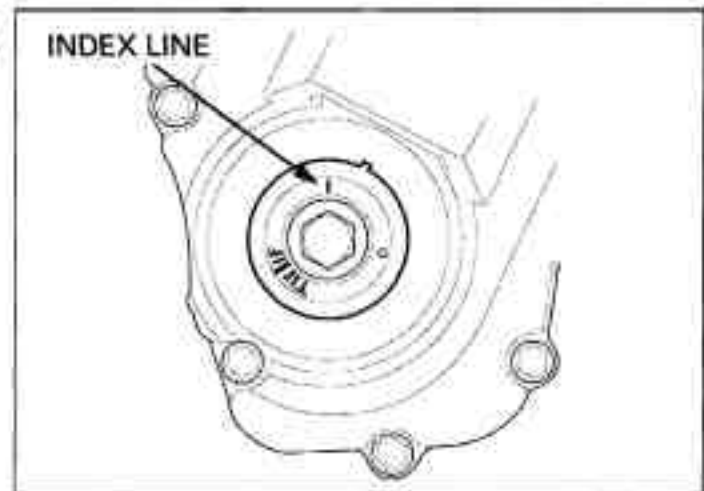

Record the clearance for each valve for reference in shim selection if adjustment is required.

Check the valve clearance for the No.1 and No.3 cylinder exhaust valves using a feeler gauge.

VALVE CLEARANCE:

EX: 0.22 ± 0.03 mm (0.009 ± 0.001 in)

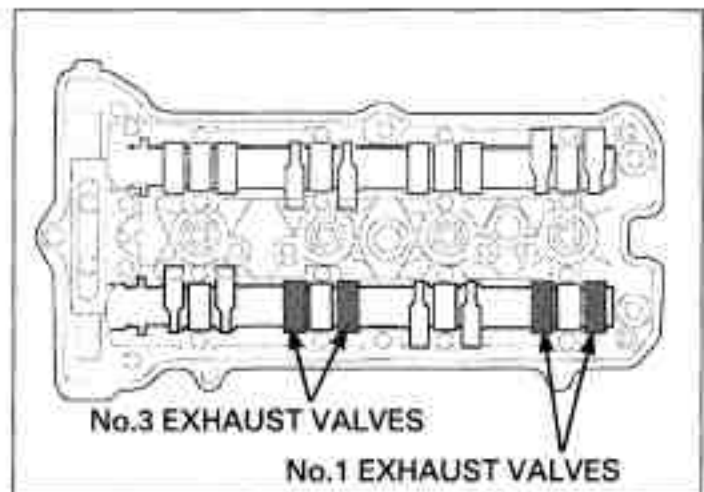

ADJUSTMENT

Remove the camshafts (page 9-7).

Remove the valve lifters and shims.

- Shim may stick to the inside of the valve lifter. Do not allow the shims to fall into the crankcase.
- Mark all valve lifters and shims to ensure correct reassembly in their original locations.
- The valve lifter can be easily removed with a valve lapping tool or magnet.
- The shims can be easily removed with a tweezers or magnet.

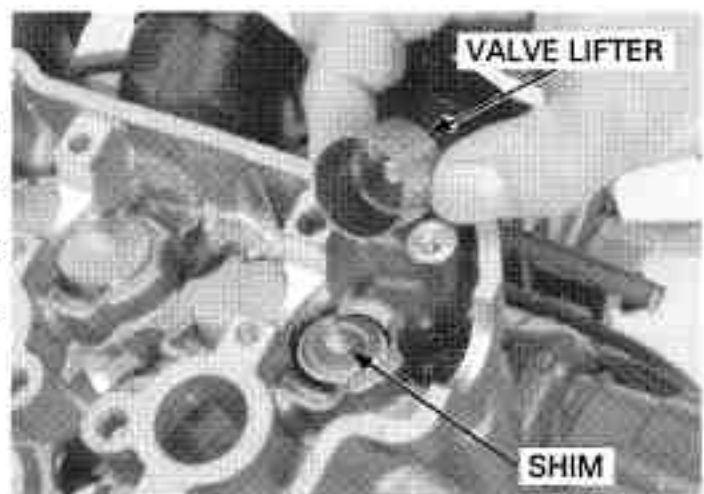

Clean the valve shim contact area in the valve lifter with compressed air.

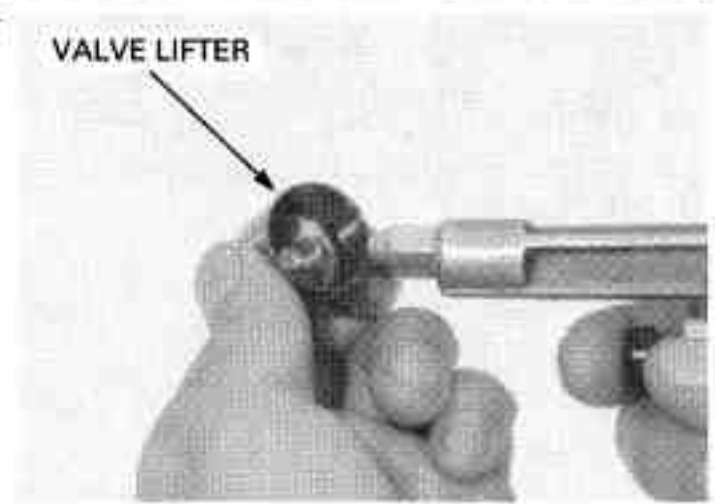

Sixty-five different thickness shims are available from the thinnest 1.200 mm thickness shim to the thickest 2.800 mm thickness shim in intervals of 0.025 mm.

Measure the shim thickness and record it.

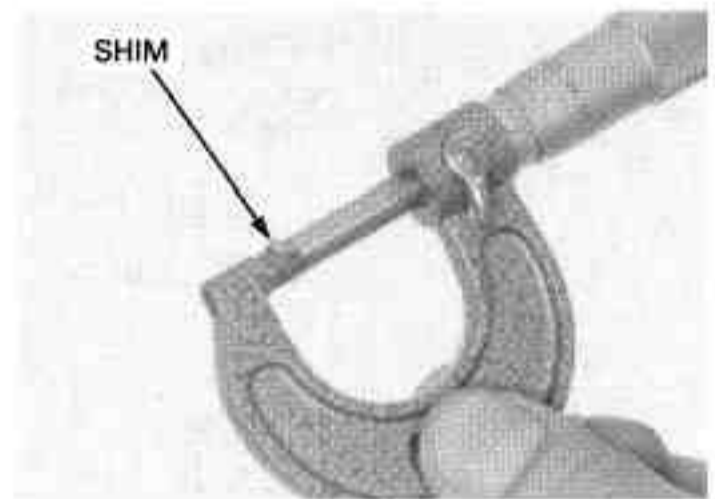

Calculate the new shim thickness using the equation below.

$$A = (B - C) + D$$

- A: New shim thickness
- B: Recorded valve clearance
- C: Specified valve clearance
- D: Old shim thickness

- Make sure of the correct shim thickness by measuring the shim by micrometer.
- Reface the valve seat if carbon deposit result in a calculated dimension of over 2.800 mm.

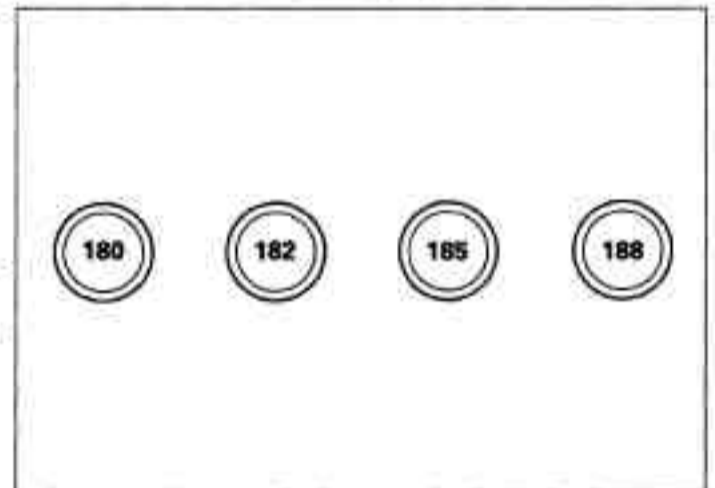

Install the shims and valve lifters in their original locations

Install the newly selected shim on the valve retainer. Apply molybdenum disulfide oil to the valve lifters. Install the valve lifters into the valve lifter holes.

Install the camshaft (page 9-27).

Rotate the camshafts by rotating the crankshaft clockwise several times.

Recheck the valve clearance.

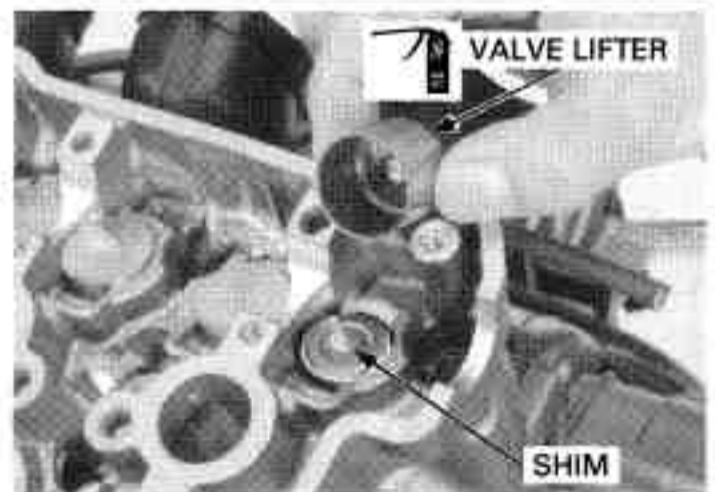

MAINTENANCE

Remove the cam chain tensioner stopper tool.
Install the new sealing washer and cam chain tensioner lifter sealing bolt.
Tighten the bolt securely.

Install the removed parts in the reverse order of removal.

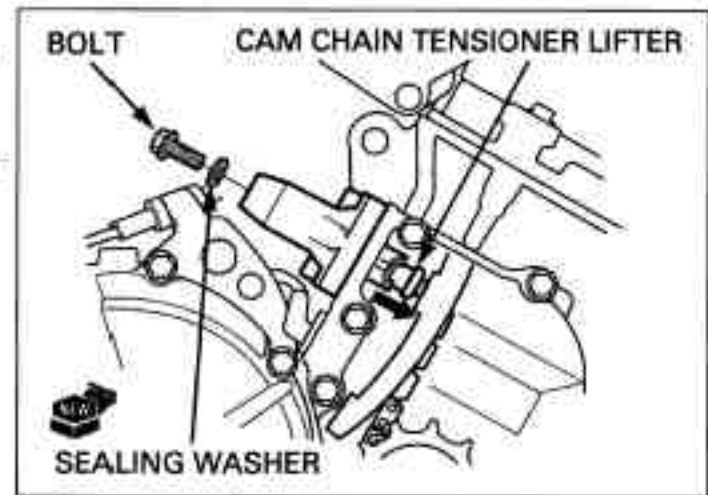

Check that the O-ring is in good condition, replace if necessary.

Apply grease to the timing hole cap threads.

Install and tighten the timing hole cap to the specified torque.

TORQUE: 18 N·m (1.8 kgf·m, 13 lbf·ft)

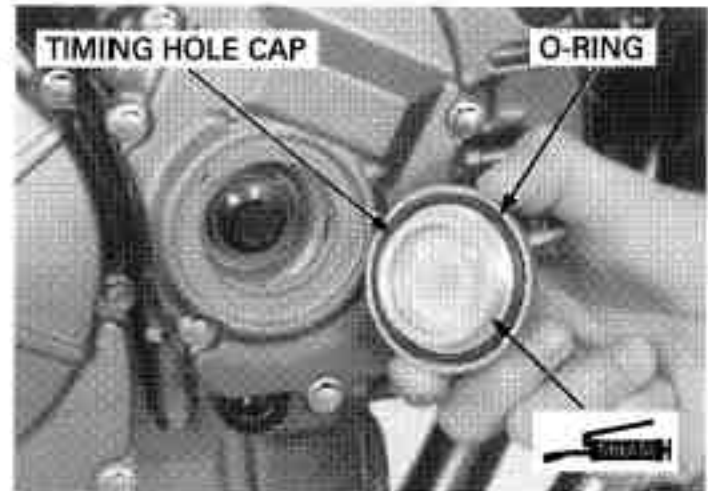

ENGINE OIL/OIL FILTER

OIL LEVEL INSPECTION

Start the engine and let it idle for 3 – 5 minutes.
Stop the engine and wait 2 – 3 minutes.
Hold the motorcycle in an upright position.

Remove the oil level dipstick and wipe the oil from the dipstick with a clean cloth.



Insert the dipstick into the stick hole without screwing it in.

Remove the dipstick and check for oil level.

If the level is below the lower line, fill the crankcase with recommended oil up to the upper level line.

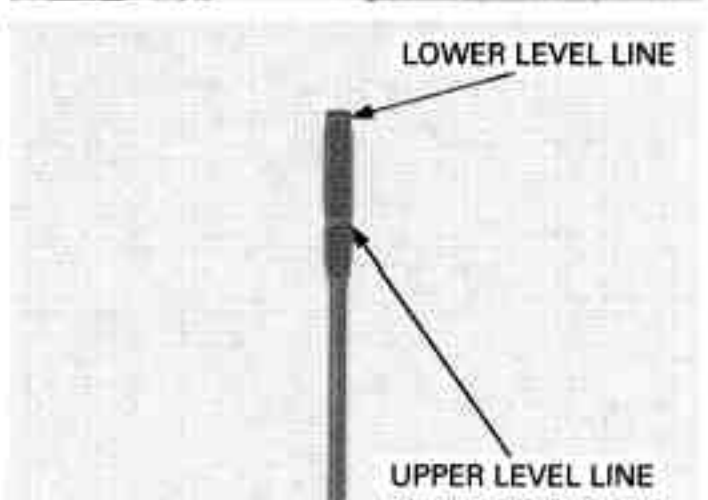

Fill the recommended engine oil up to the upper level line.

Other viscosities shown in the chart may be used when the average temperature in your riding area is within the indicated range.

RECOMMENDED ENGINE OIL:

Pro Honda GN4 or HP4 (Without molybdenum additives) 4-stroke oil or equivalent motor oil
API service classification: SG or Higher
JASO T 903 standard: MA
Viscosity: 10W-40

Reinstall the oil level dipstick.

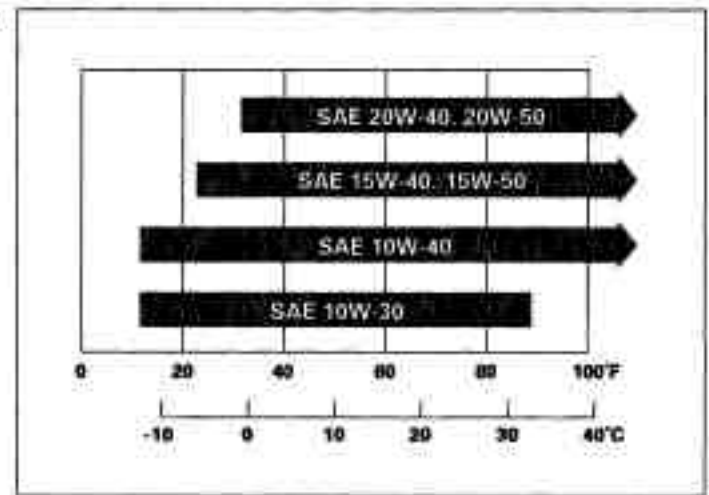

ENGINE OIL & FILTER CHANGE

Warm up the engine.

Change the oil with the engine warm and the motorcycle on level ground to assure complete draining

Stop the engine and remove the oil level dipstick.

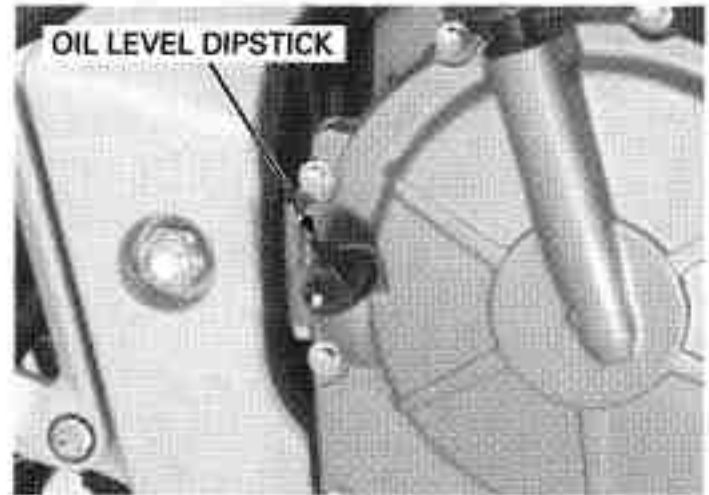

Remove the drain bolt and sealing washer, then drain the oil completely.



Remove and discard the oil filter cartridge using the special tool.

TOOL:
Oil filter wrench 07HAA-PJ70101 or 07HAA-PJ70100 (U.S.A. only)

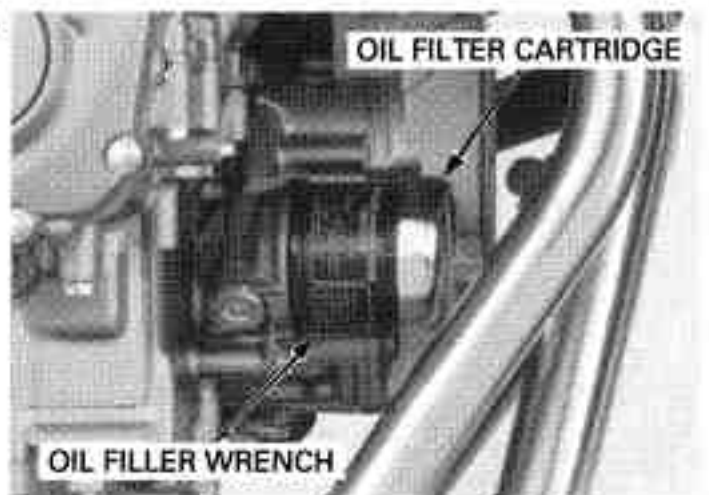

MAINTENANCE

Check that the sealing washer on the drain bolt is in good condition, and replace if necessary. Install and tighten the drain bolt.

TORQUE: 29 N·m (3.0 kgf·m, 22 lbf·ft)

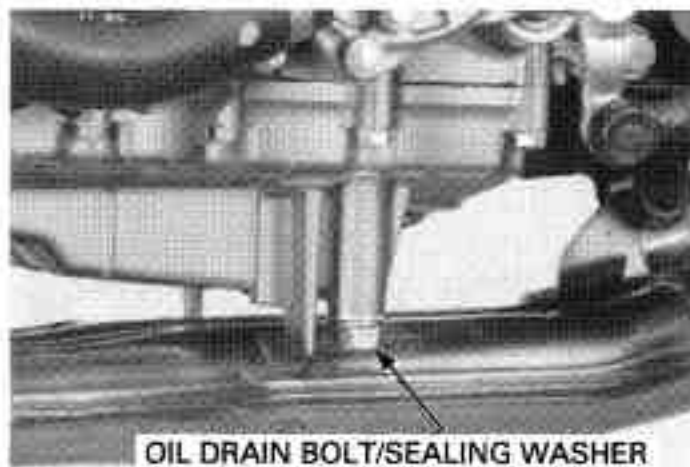

Apply clean engine oil to the new oil filter O-ring.

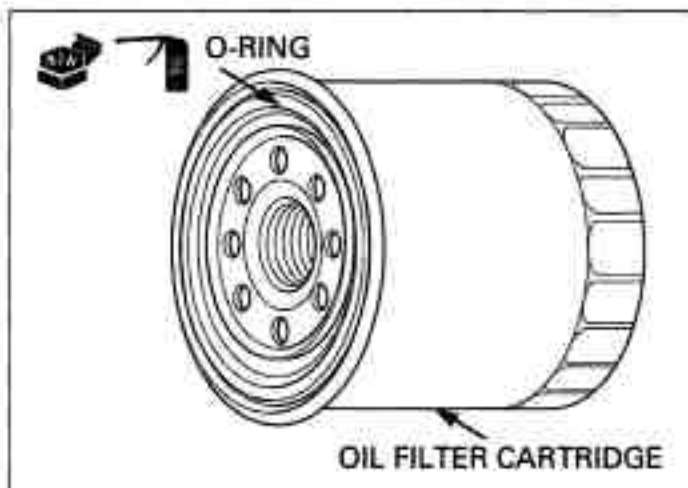

Install the new oil filter and tighten it to the specified torque.

TOOL:

Oil filter wrench 07HAA-PJ70101 or
07HAA-PJ70100 (U.S.A. only)

TORQUE: 25 N·m (2.5 kgf·m, 18 lbf·ft)

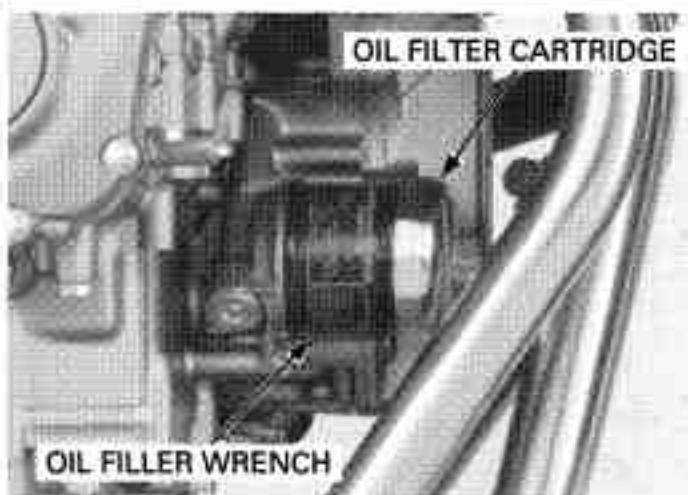

Fill the crankcase with recommended engine oil.

OIL CAPACITY:

3.5 liter (3.7 US qt, 3.1 Imp qt) after draining
3.8 liter (4.0 US qt, 3.3 Imp qt) after draining/filter
change

Install the oil level dipstick.

Start the engine and let it idle for 3 - 5 minutes.
Stop the engine and wait 2 - 3 minutes.
Recheck the oil level.
Make sure there are no oil leaks.

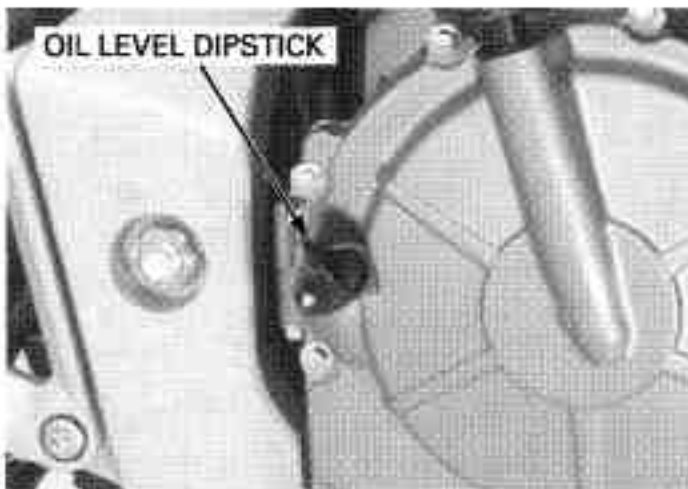

CARBURETOR SYNCHRONIZATION (‘04 model)

- Synchronize the carburetors with the engine at the normal operating temperature and with the transmission in neutral.
- Use a tachometer with graduations of 50 rpm or smaller that will accurately indicate 50 rpm change.

Place the motorcycle on a level surface, and support it in an upright position.

Remove the fuel tank (page 3-6).

Remove the plug and washer from the No.1 intake port.

Remove the rubber cap from the No.4 intake port.

Screw the adaptor into the No.1 intake port.

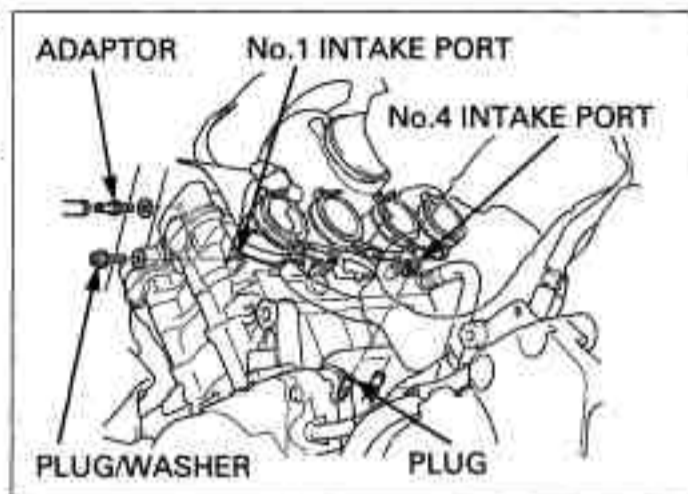

Disconnect the vacuum hoses from the No.2 and No.3 intake ports.

Connect the 3-way joint to the No.2 intake joint.

Connect the fuel hose.

Connect the fuel valve vacuum hose to the 3-way joint.

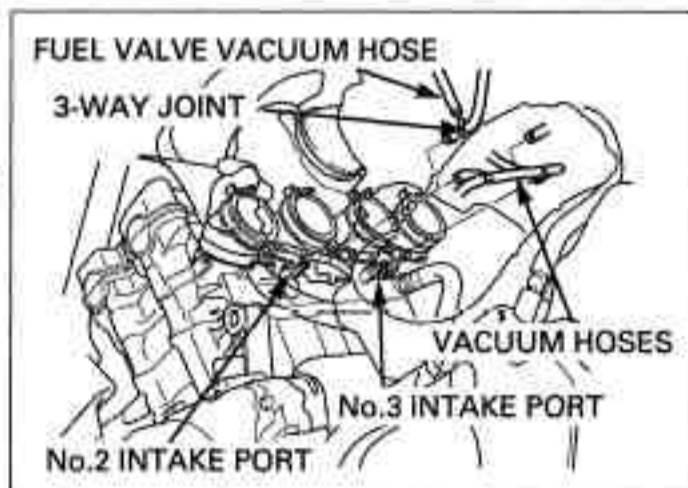

Connect the vacuum gauge hose to the adaptor and intake joints.

TOOL:

Vacuum gauge set 07LMJ-001000A (U.S.A. only) or
07LMJ-001000B (U.S.A. only)

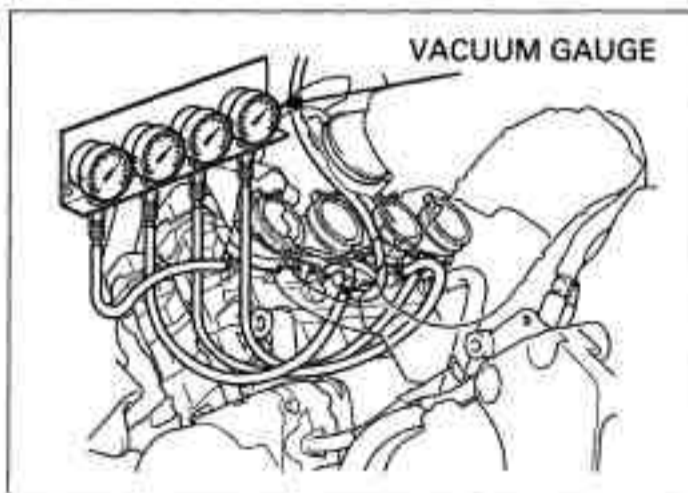

MAINTENANCE

Start the engine and adjust the idle speed by turning the throttle stop screw.

IDLE SPEED: $1,400 \pm 100$ rpm

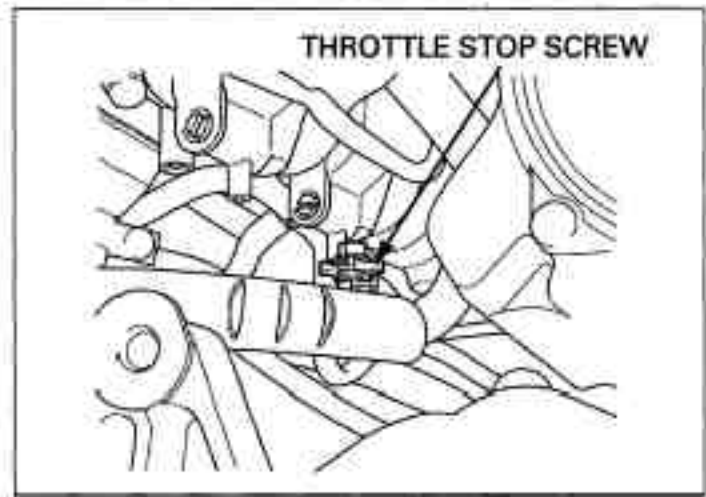

The No.3 carburetor cannot be adjusted, it is the base carburetor.

Check that each carburetor intake vacuum pressure is within 30 mm (1.2 in) Hg of the base carburetor.

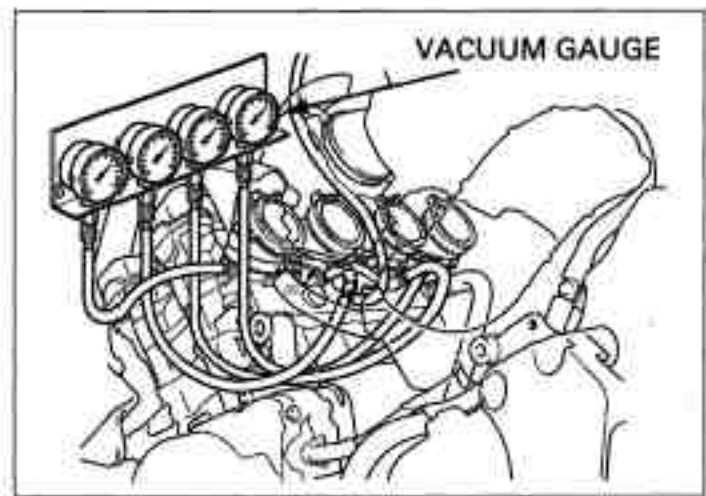

Synchronize to specification by turning the adjusting screw with the Phillips screwdriver.

Recheck the idle speed and each cylinder intake vacuum pressure so that it is within 30 mm (1.2 in) Hg of the base carburetor reading after snapping the throttle grip 3 - 4 times.

Remove the vacuum gauge hoses.
Connect the fuel valve vacuum hose and PAIR control valve hose.
Install the rubber cap to the No.4 intake port.
Install the vacuum plug into the No.1 intake port, and tighten it securely.

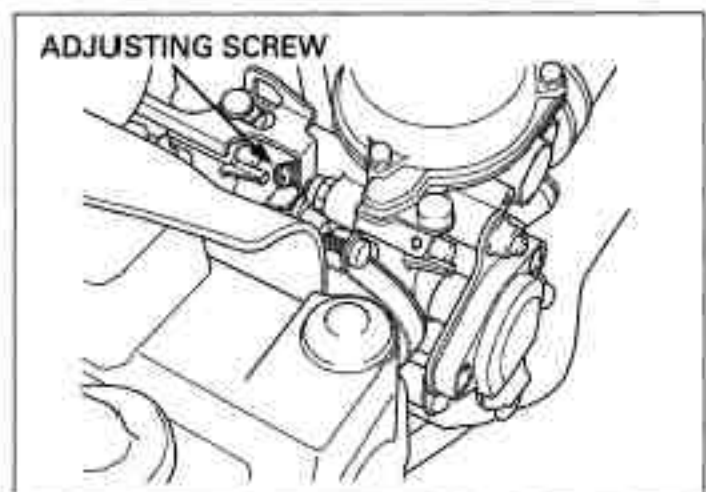

CARBURETOR SYNCHRONIZATION (After '04 model)

- Synchronize the carburetors with the engine at the normal operating temperature and with the transmission in neutral.
- Use a tachometer with graduations of 50 rpm or smaller that will accurately indicate 50 rpm change.

Place the motorcycle on a level surface and support it in an upright position.

Remove the fuel tank (page 3-6).

Remove the PAIR control valve vacuum hose and connect the vacuum gauge to the hose that is from No.1 carburetor.

Remove the rubber cap from No.2 intake port and connect the vacuum gauge hose.

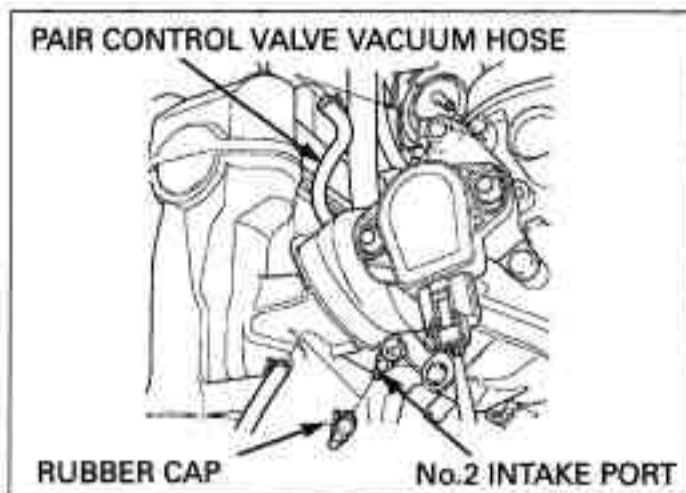

Disconnect the fuel valve vacuum hose from the fuel valve and connect the 3-way joint to the fuel valve vacuum hose.

Connect a hose between the 3-way joint and the fuel valve.

Connect the vacuum gauge hose to the 3-way joint for No.3 carburetor.

Except California type:

Remove the rubber cap from the No.4 carburetor and connect the vacuum gauge hose into the No.4 carburetor.

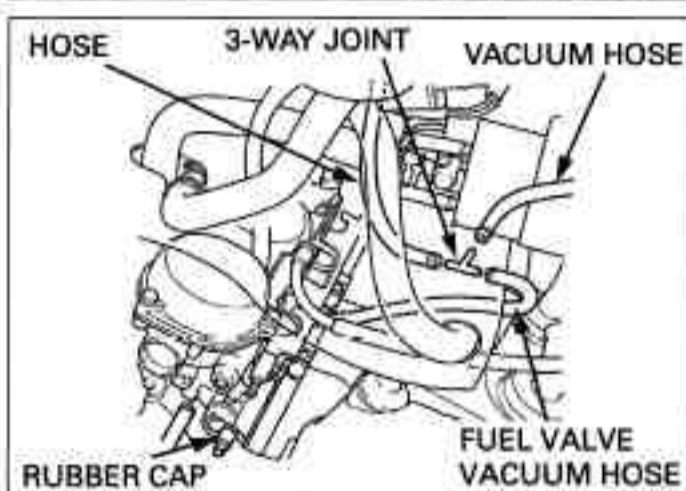

California type:

Remove the EVAP CAV control valve vacuum hose (to the EVAP CAV control valve) from the No.4 carburetor and connect the vacuum gauge hose into the No.4 carburetor.

Remove the fuel cutoff solenoid suction hose (No.6 hose) from the fuel cutoff solenoid in order to keep the float chambers in atmosphere pressure.

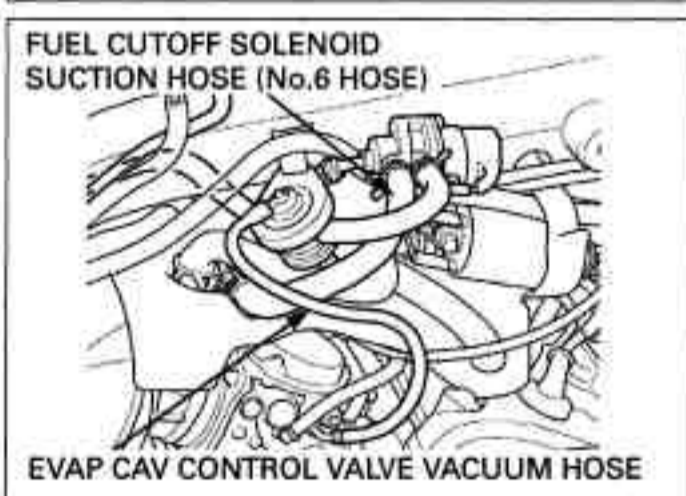

MAINTENANCE

Connect the vacuum gauge to each vacuum hose and check the connection as follows.

VACUUM GAUGE HOSE CONNECTION

- No.1 PAIR control valve vacuum hose
- No.2 Hose joint on carburetor insulator
- No.3 Fuel valve vacuum hose with 3-way joint
 - Except California type:
 - Hose joint on the carburetor
- No.4 California type:
 - EVAP CAV control valve vacuum hose

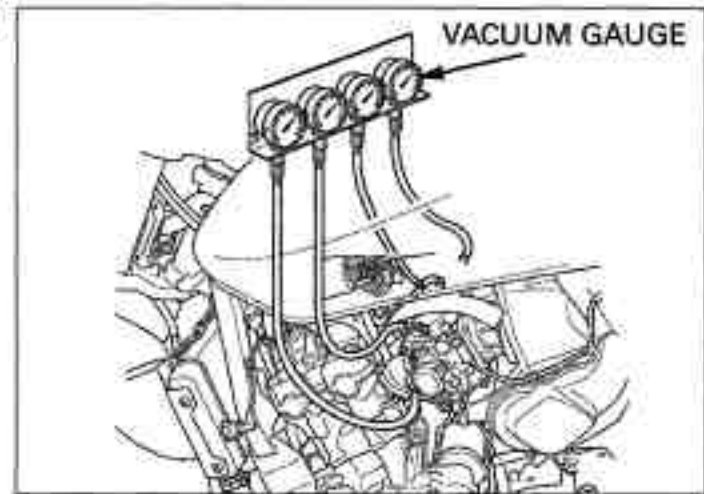

Start that engine and adjust the idle speed by turning the throttle stop screw.

IDLE SPEED: 1,400 ± 100 rpm

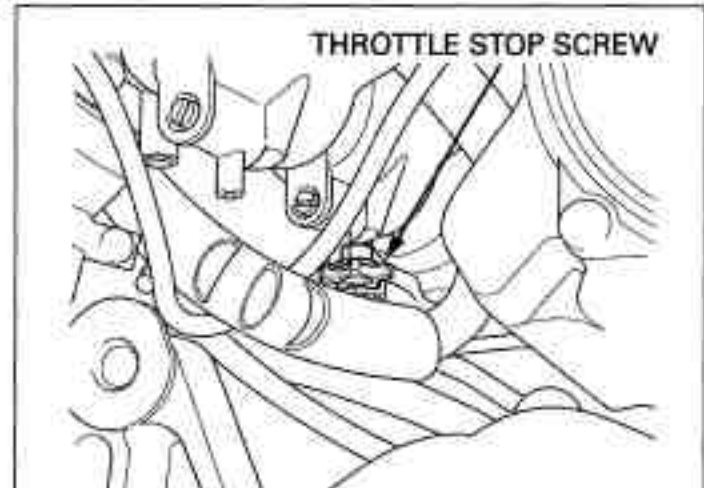

The No.3 carburetor cannot be adjusted, it is the base carburetor.

Check that each carburetor intake vacuum pressure difference is within 30 mm (1.2 in) Hg of the base carburetor.

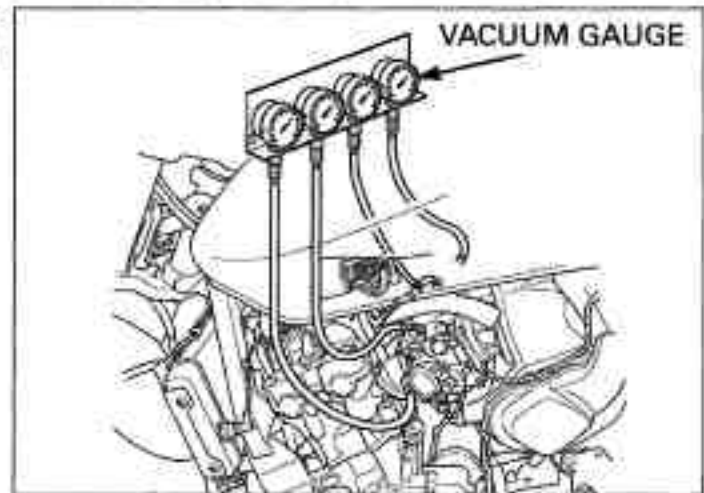

Synchronize to specification by turning the adjusting screw with the Phillips screwdriver.

Recheck the idle speed and each cylinder intake vacuum pressure difference so that it is within 30 mm (1.2 in) Hg of the base carburetor reading after snapping the throttle grip 3 - 4 times.

Remove the vacuum gauge hoses.
Connect the fuel valve vacuum hose and PAIR control valve hose.
Install the rubber cap into the No.2 carburetor insulator.

Except California type:

Install the rubber cap to the No.4 carburetor.

California type:

Install the fuel cutoff solenoid suction hose (No.6 hose) to the fuel cutoff solenoid.
Install the vacuum hose (from the No.4 carburetor) to the EVAP CAV control valve.

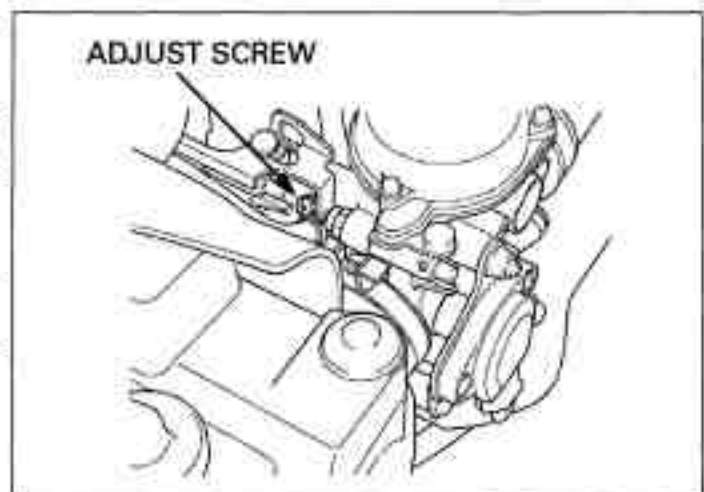

ENGINE IDLE SPEED

- Inspect and adjust the idle speed after all other engine maintenance items have been performed and are within specifications.
- The engine must be warm for accurate idle speed inspection and adjustment.

Warm up the engine.

Turn the throttle stop screw as required to obtain the specified idle speed.

IDLE SPEED: 1,400 ± 100 rpm

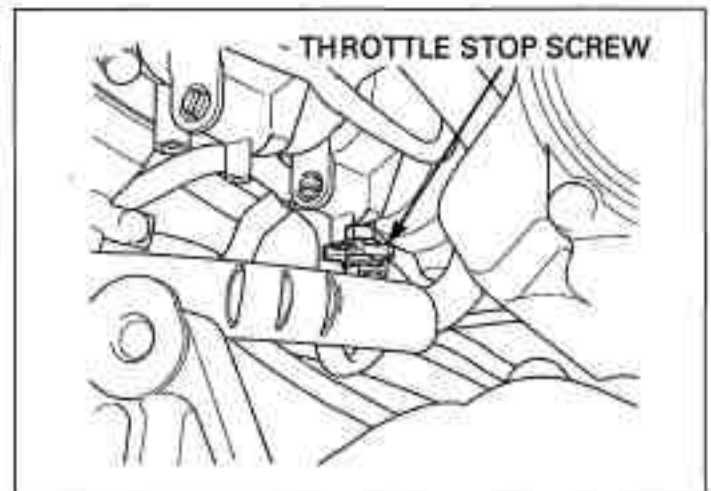

RADIATOR COOLANT

Check the coolant level of the reserve tank with the engine running at normal operating temperature.

The level should be between the "UPPER" and "LOWER" level lines.

If necessary, add recommended coolant.

RECOMMENDED ANTIFREEZE:

High quality ethylene glycol antifreeze containing corrosion protection inhibitors.

Remove the seat (page 3-4).

Remove the reserve tank filler cap and fill to the "UPPER" level line with 50/50 mixture of distilled water and antifreeze.

Reinstall the filler cap.

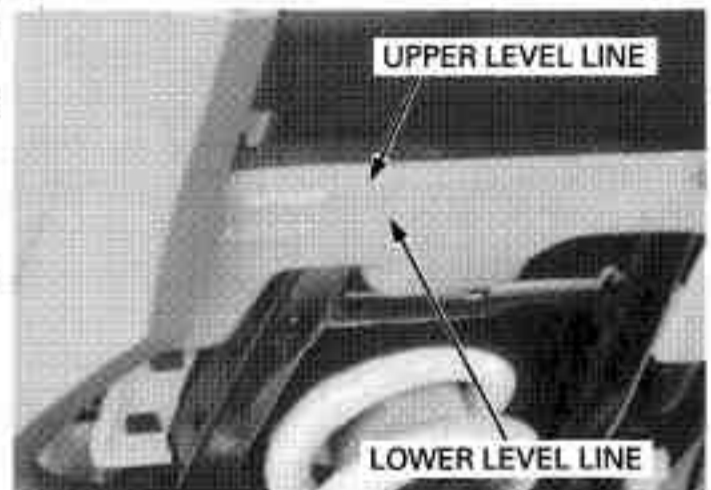

COOLING SYSTEM

Check the radiator air passages for clogging or damage.

Straighten bend fins, and remove insects, mud or other obstructions with compressed air or low water pressure.

Replace the radiator if the air flow is restricted over more than 20% of the radiating surface.



MAINTENANCE

Inspect the radiator hoses for cracks or deterioration, and replace if necessary. Check the tightness of all hose clamps and fasteners.

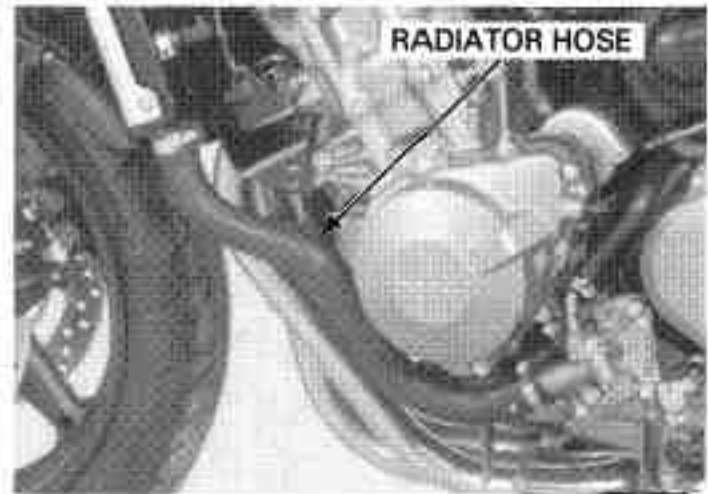

SECONDARY AIR SUPPLY SYSTEM

- This model is equipped built-in secondary air supply system. The pulse secondary air supply system is located on the cylinder head cover.
- The secondary air supply system introduces filtered air into exhaust gases in the exhaust port. The secondary air is drawn into the exhaust port whenever there is negative pressure pulse in the exhaust system. This charged secondary air promotes burning of the unburned exhaust gases and changes a considerable amount of hydrocarbons and carbon monoxide into relatively harmless carbon dioxide and water.

Remove the fuel tank (page 3-6).

If the hoses show any signs of heat damage, inspect the PAIR check valve in the PAIR read valve cover for damage.

Check the PAIR (pulse secondary air injection) hoses between the PAIR control valve and cylinder head cover for deterioration, damage or loose connections. Make sure that the hoses are not cracked.



Check the air suction hose between the air cleaner housing and PAIR control valve for deterioration, damage or loose connections. Make sure that the hoses are not kinked, pinched or cracked.

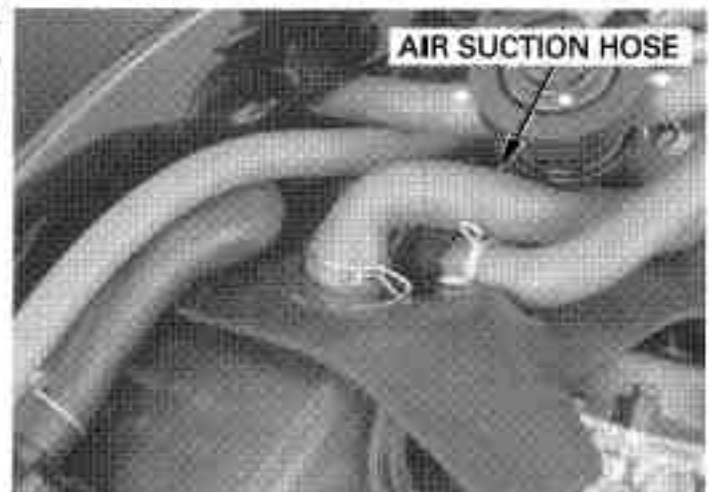

EVAPORATIVE EMISSION CONTROL SYSTEM

Check the hoses between the fuel tank, EVAP canister, EVAP purge control valve for deterioration, damage or loose connections.

Check the EVAP canister for cracks or other damage.

Refer to the Vacuum Hose Routing Diagram Label (page 1-52) and cable & Harness Routing (page 1-23) for hose connections.

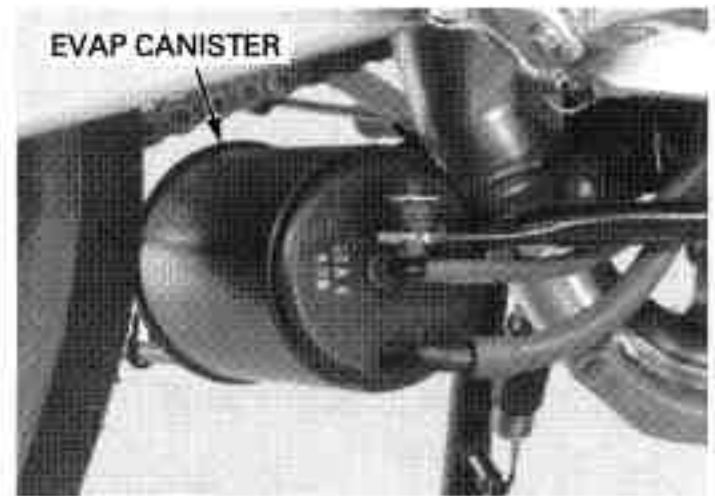

DRIVE CHAIN

Never inspect and adjust the drive chain while the engine is running.

DRIVE CHAIN SLACK INSPECTION

Turn the ignition switch OFF, place the motorcycle on its side stand and shift the transmission into neutral.

Check the slack in the drive chain lower run midway between the sprockets.

CHAIN SLACK: 30 – 40 mm (1.2 – 1.6 in)

NOTICE

Excessive chain slack, 50 mm (2.0 in) or more, may damage the frame.

Lubricate the drive chain with #80 – 90 gear oil or chain lubricant designed specifically for use with O-ring chains. Wipe off the excess oil or chain lubricant.

ADJUSTMENT

Loosen the rear axle nut and adjuster lock nuts.

Turn both adjusting nuts until the correct drive chain slack is obtained.

Make sure the index marks on the both axle washers are aligned with the index marks of the swing-arm.

Tighten the both drive chain adjuster lock nuts to the specified torque.

TORQUE: 21 N·m (2.1 kgf·m, 15 lbf·ft)

Tighten the rear axle nut to the specified torque.

TORQUE: 88 N·m (9.0 kgf·m, 65 lbf·ft)

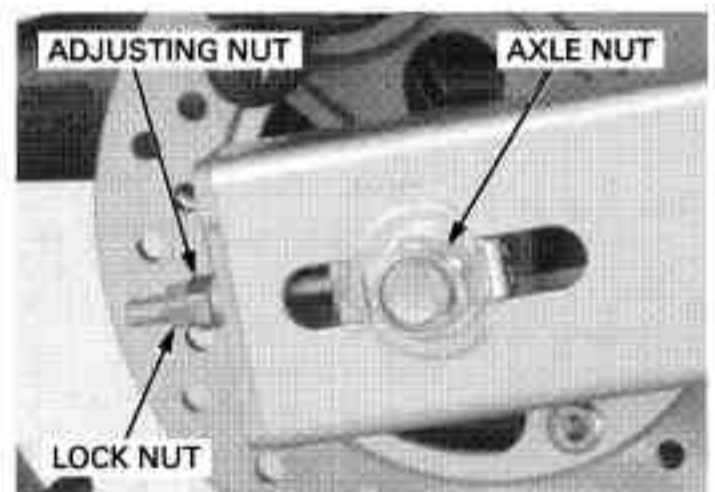
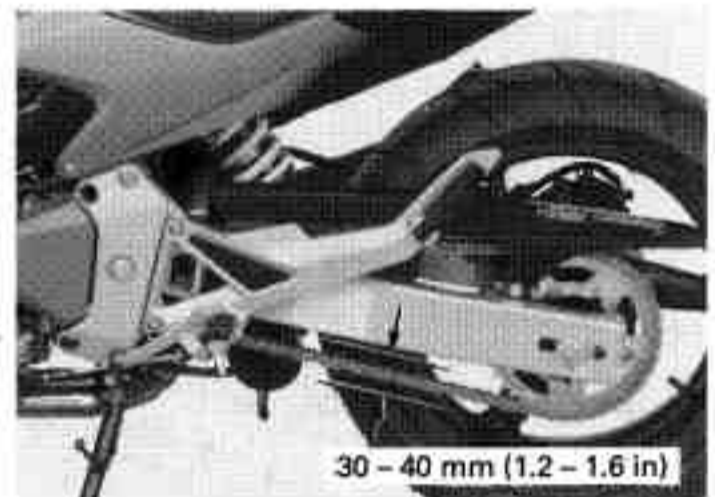

MAINTENANCE

Recheck the drive chain slack and free wheel rotation.

Lubricate the drive chain with #80 – 90 gear oil or drive chain lubricant designed specifically for use with O-ring chains. Wipe off the excess oil or chain lubricant.

Check the drive chain wear indicator label attached on the swingarm.

If the rear axle washer index mark reaches red zone of the indicator label, replace the drive chain with a new one (page 4-25).

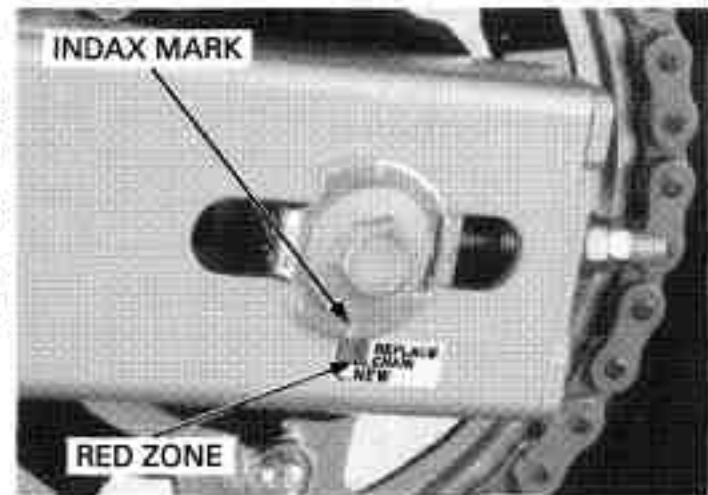

CLEANING AND LUBRICATION

Clean the chain with non-flammable or high flash point solvent and wipe it dry.

Be sure the chain has dried completely before lubricating.

Inspect the drive chain for possible damage or wear. Replace any chain that has damaged rollers, loose fitting links, or otherwise appears unserviceable.

Installing a new chain on badly worn sprockets will cause the new chain to wear quickly.

Inspect and replace sprocket as necessary.

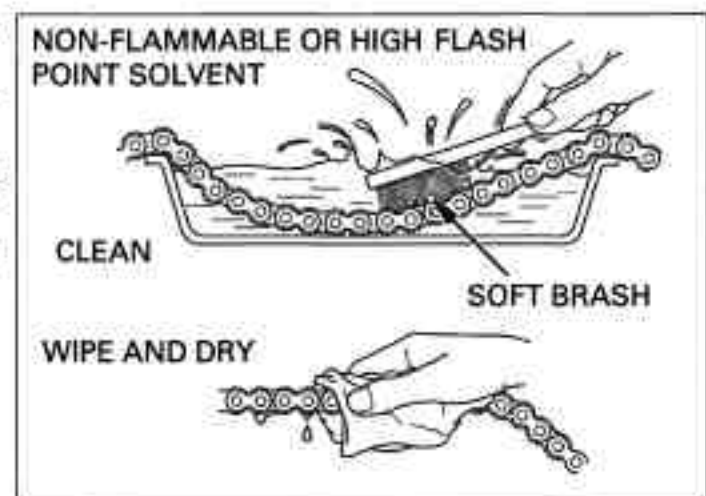

Lubricate the drive chain with #80 – 90 gear oil or drive chain lubricant designed specifically for use with O-ring chains. Wipe off the excess oil or chain lubricant.

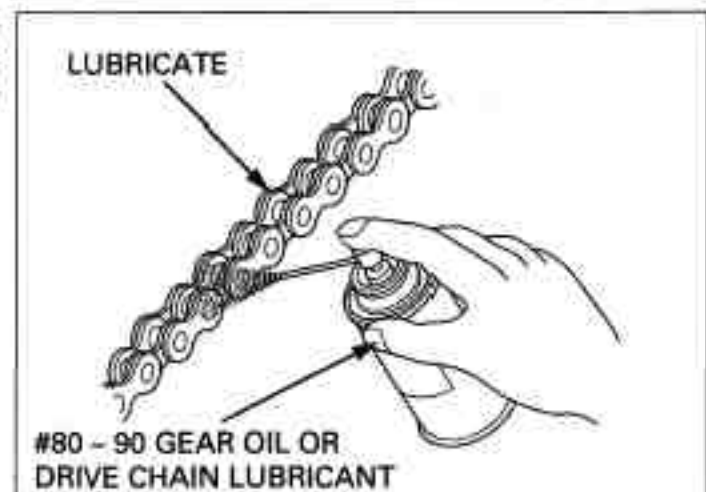

SPROCKETS INSPECTION

Inspect the drive and driven sprocket teeth for wear or damage, replace if necessary.

Never use a new drive chain on worn sprockets.

Both chain and sprockets must be in good condition, or the new replacement chain will wear rapidly.

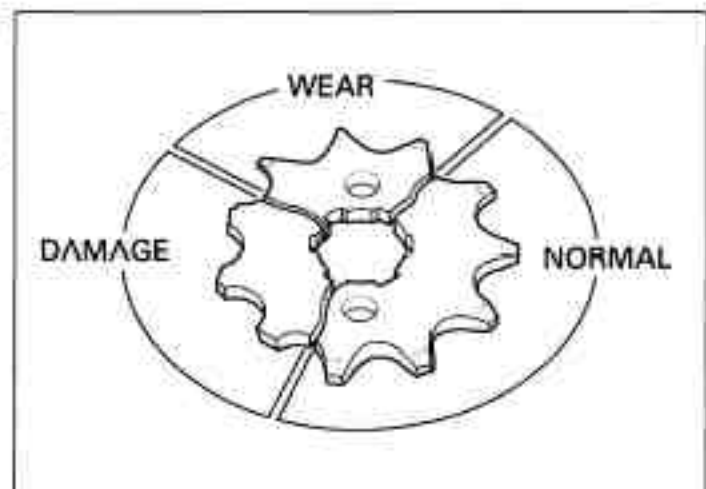

Check the attaching bolts and nuts on the drive and driven sprockets.
If any are loose, torque them.

TORQUE:

Drive sprocket special bolt:
54 N·m (5.5 kg·m, 40 lbf·ft)

Final driven sprocket nut:
108 N·m (11.0 kgf·m, 80 lbf·ft)

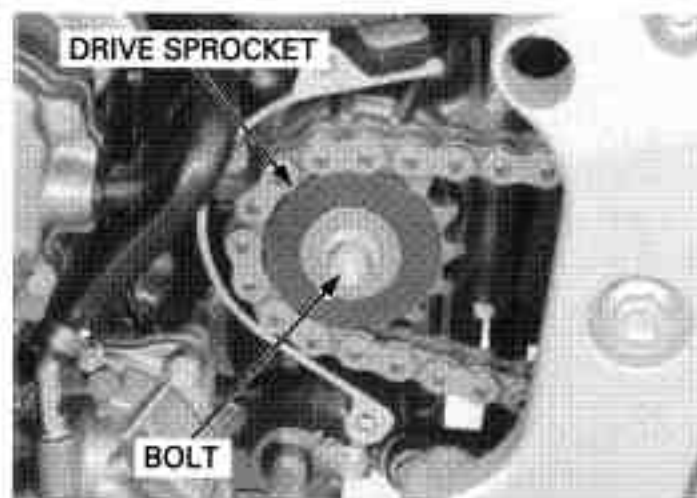

REPLACEMENT

This motorcycle uses a drive chain with a staked master link.

Loosen the drive chain (page 4-23).

Assemble the special tool as shown.

TOOL:

Drive chain tool set 07HMH-MR10103 or 07HMH-MR1010C (U.S.A. only)

When using the special tool, follow the manufacturer's instruction.

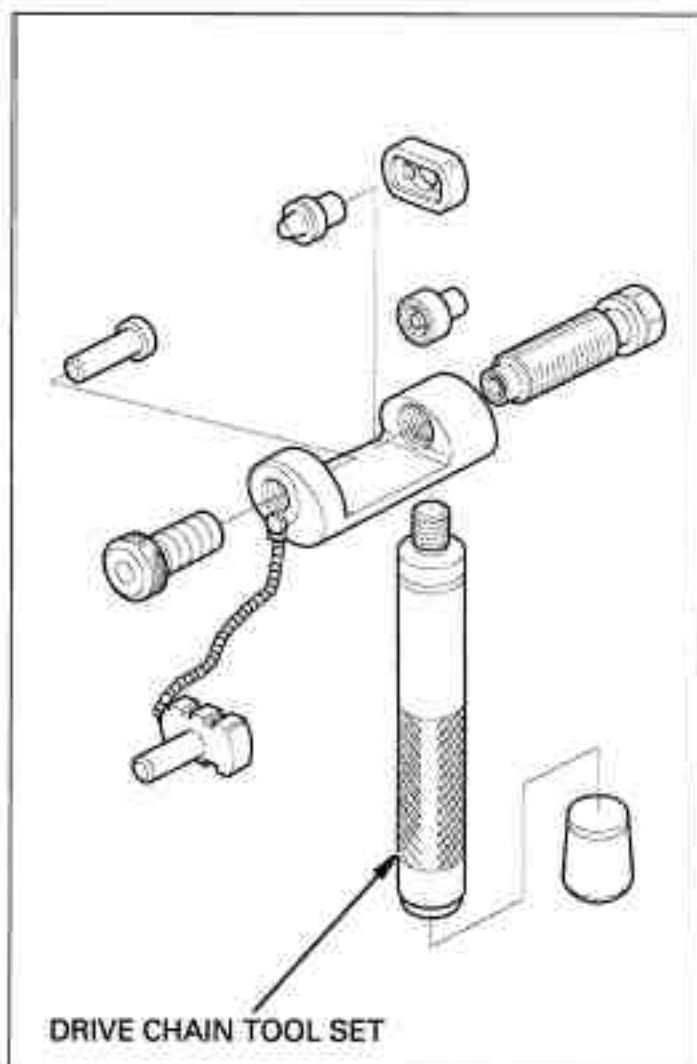

Locate the crimped pin ends of the master link from the outside of the chain, and remove the link with the drive chain tool set.

TOOL:

Drive chain tool set 07HMH-MR10103 or 07HMH-MR1010C (U.S.A. only)

Remove the drive chain.

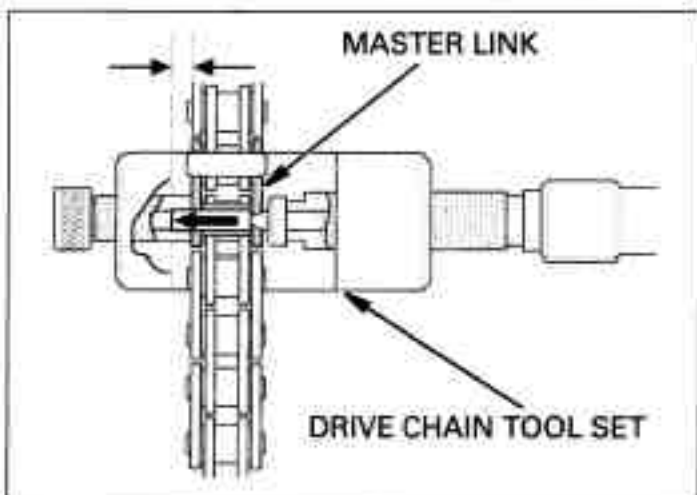

MAINTENANCE

Include the master link when you count the drive chain links.

Remove the excess drive chain links from the new drive chain with the drive chain tool set.

STANDARD LINKS: 110 LINKS

REPLACEMENT CHAIN

DID: 525VM2-120ZB

RK: 525RO-120LJ-FZ

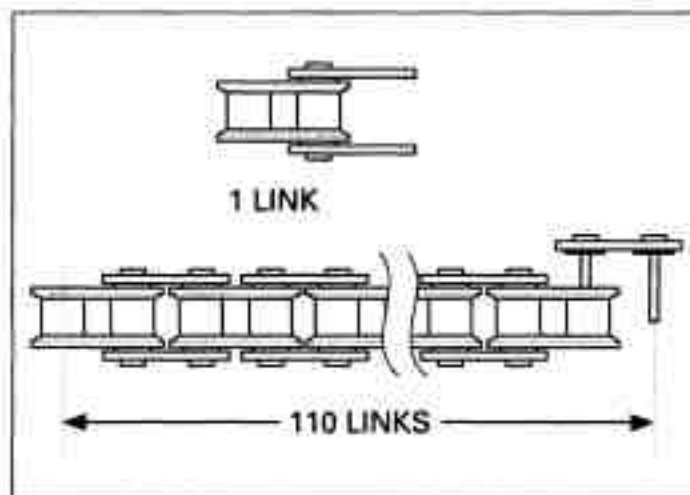

Never reuse the old drive chain, master link, master link plate and O-rings.

Insert the new master link with new O-rings from the inside of the drive chain, and install the new plate and O-rings with the identification mark facing the outside.

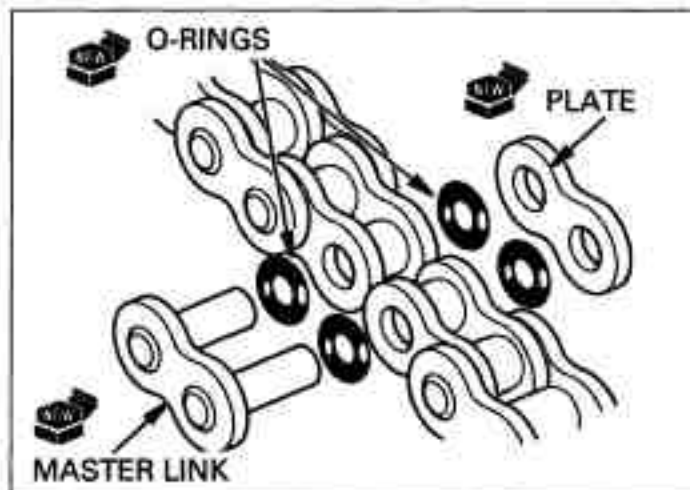

Assemble and set the drive chain tool set.

TOOL:

Drive chain tool set 07HMH-MR10103 or 07HMH-MR1010C (U.S.A. only)

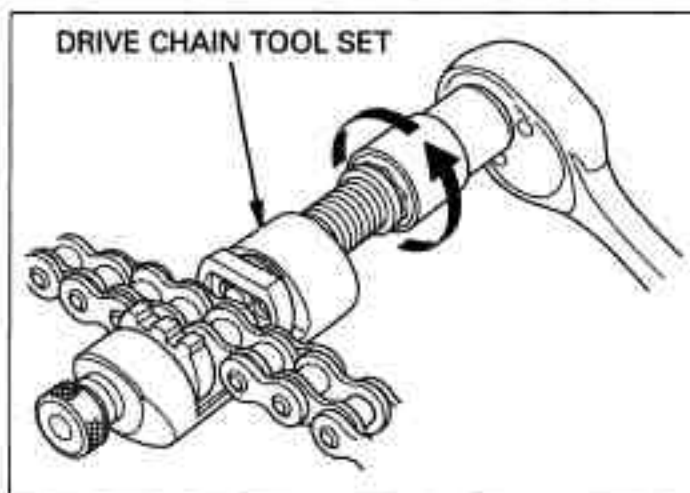

Make sure that the master link pins are installed properly.

Measure the master link pin length projected from the plate.

STANDARD LENGTH::

DID: 1.15 – 1.55 mm (0.045 – 0.061 in)

RK: 1.2 – 1.4 mm (0.05 – 0.06 in)

Stake the master link pins.

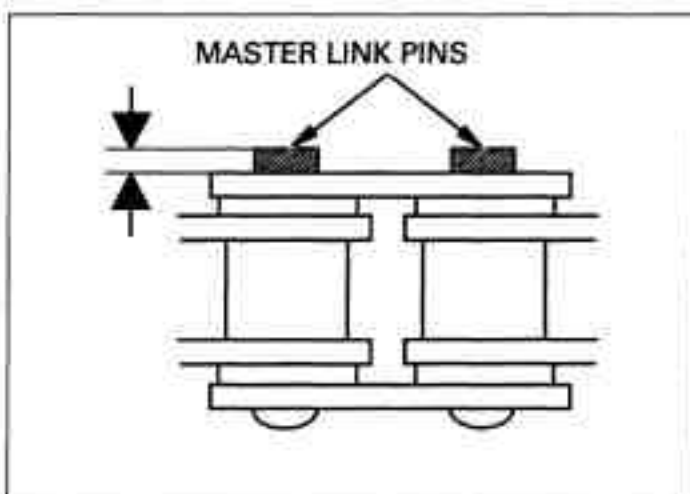

Make sure that the pins are staked properly by measuring the diameter of the staked area using a slide caliper.

DIAMETER OF THE STAKED AREA:

DID: 5.50 – 5.80 mm (0.217 – 0.228 in)

RK: 5.50 – 5.80 mm (0.217 – 0.228 in)

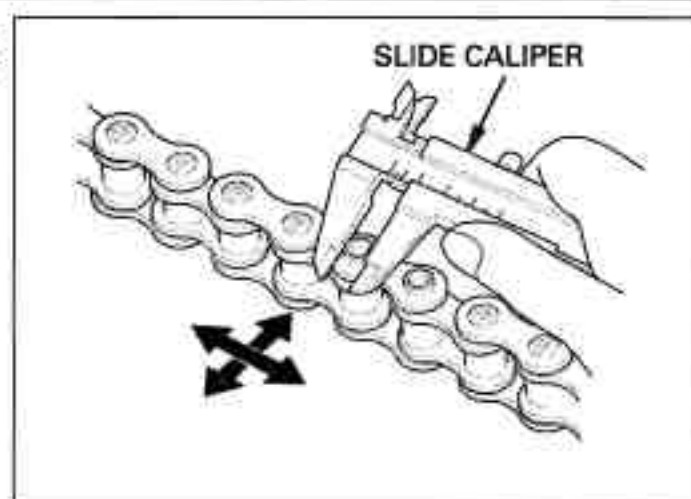

A drive chain with a clip-type master link must not be used.

After staking, check the staked area of the master link for cracks.

If there is any cracking, replace the master link, O-rings and plate.

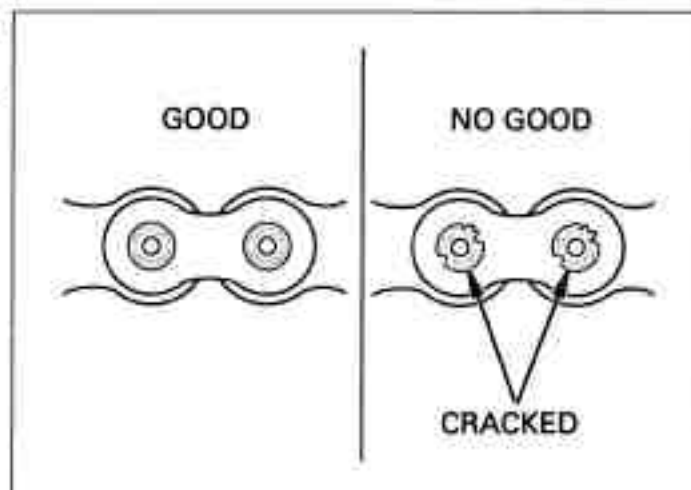

BRAKE FLUID

NOTICE

- Do not mix different types of fluid, as they are not compatible with each other.
- Do not allow foreign material to enter the system when filling the reservoir.
- Avoid spilling fluid on painted, plastic or rubber parts. Place a rag over these parts whenever the system is serviced.

When the fluid level is low, check the brake pads for wear (page 4-28). A low fluid level may be due to wear of the brake pads. If the brake pads are worn, the caliper piston is pushed out, and this accounts for a low reservoir level. If the brake pads are not worn and the fluid level is low, check entire system for leaks (page 4-28).

FRONT BRAKE

Turn the handlebar to the left so that the reservoir is level and check the front brake fluid reservoir level. If the level is near the lower level line, check the brake pad wear (page 4-28).



MAINTENANCE

REAR BRAKE

Remove the side cover (page 3-4).

Place the motorcycle on a level surface, and support it upright position.

Check the rear brake fluid reservoir level.

If the level is near the lower level line, check the brake pad wear (page 4-28).

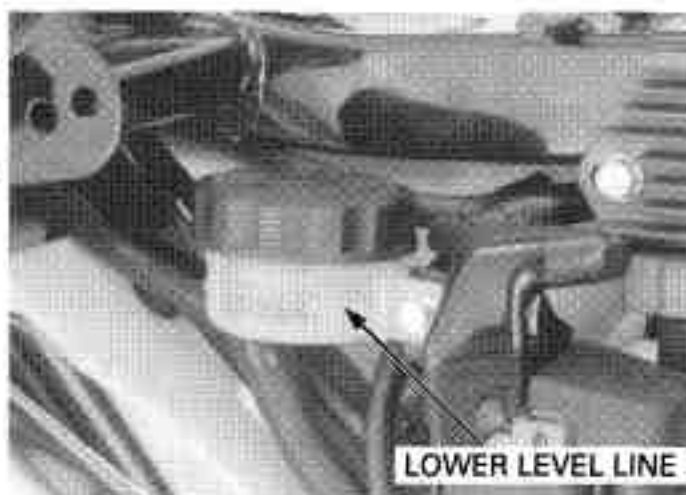

BRAKE PAD WEAR

FRONT BRAKE PADS

Check the brake pad for wear.

Replace the brake pads if either pad is worn to the bottom of wear limit groove.

Refer to brake pad replacement (page 16-9).



REAR BRAKE PADS

Check the brake pad for wear.

Replace the brake pads if either pad is worn to the bottom of wear limit groove.

Refer to brake pad replacement (page 16-10).



BRAKE SYSTEM

INSPECTION

Firmly apply the brake lever or pedal, and check that no air has entered the system.

If the lever or pedal feels soft or spongy when operated, bleed the air from the system.

Inspect the brake hose and fittings for deterioration, cracks and signs of leakage.

Tighten any loose fittings.

Replace hoses and fittings as required.

Refer the procedure for brake bleeding (page 16-7).

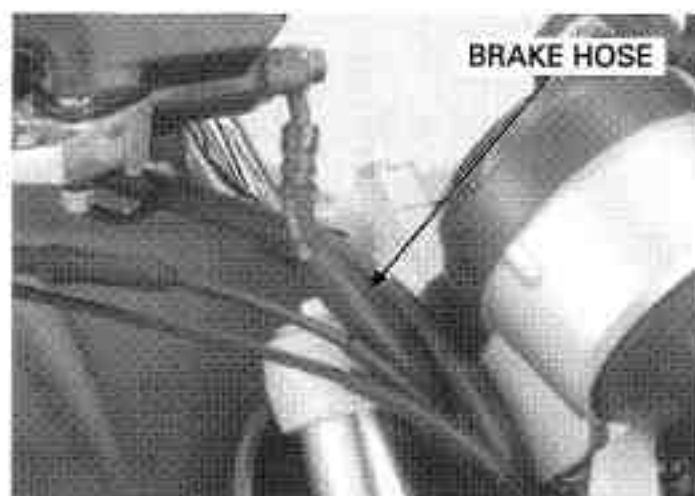

BRAKE LEVER ADJUSTMENT

Align the arrow on the brake lever with the index number on the adjuster.

The distance between the top of the brake lever and the grip can be adjusted by turning the adjuster.

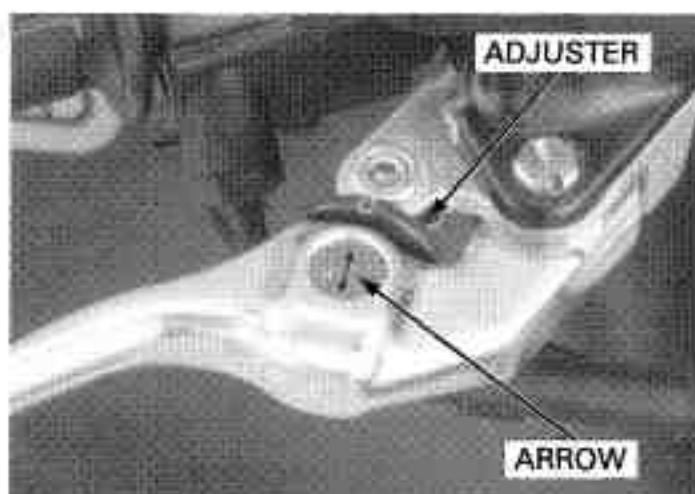

BRAKE LIGHT SWITCH

The front brake light switch does not require adjustment.

Adjust the brake light switch so that the brake light comes on just prior to the brake actually being engaged.

If the light fails to come on, adjust the switch so that the light comes on at the proper time.

Hold the switch body and turn the adjuster. Do not turn the switch body.

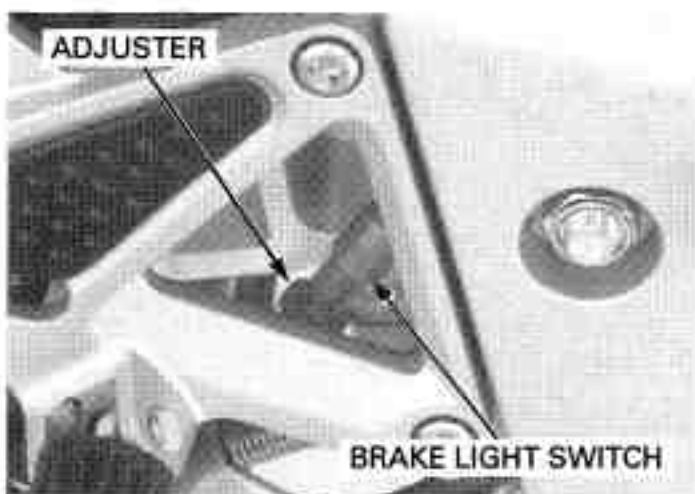

MAINTENANCE

HEADLIGHT AIM

Place the motorcycle on a level surface.

Adjust the headlight beam as specified by local laws and regulations.

Adjust the headlight beam horizontally by turning the horizontal beam adjusting screw. A clockwise rotation moves the beam toward the right side of the rider.



Adjust the headlight beam vertically by moving the headlight case assembly.

Loosen the headlight case mounting bolts and adjust the vertical beam by moving the headlight case assembly.

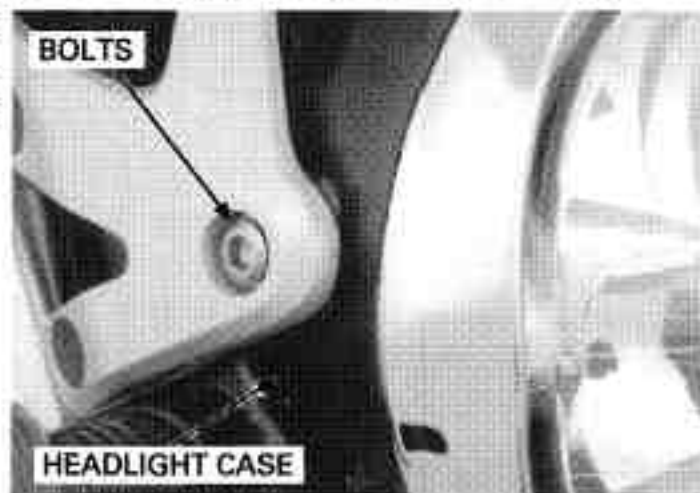

CLUTCH SYSTEM

Measure the clutch lever free play at the end of the clutch lever.

FREE PLAY: 10 – 20 mm (3/8 – 13/16 in)

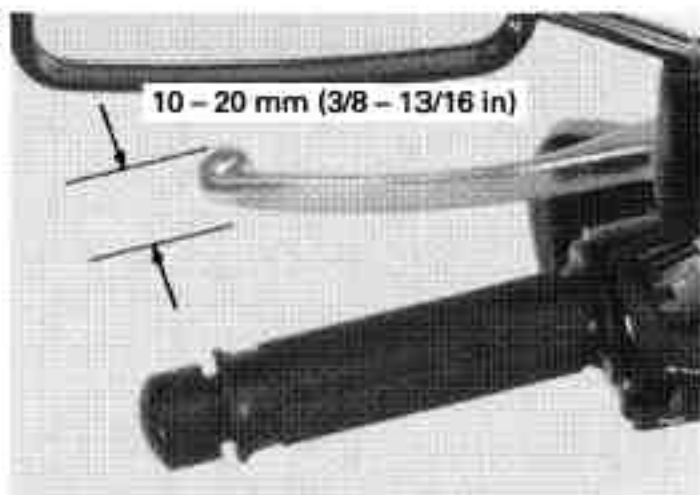

Minor adjustments are made using the upper adjuster at the clutch lever.

Loosen the lock nut and turn the adjuster.

NOTICE

The adjuster may be damaged if it is positioned too far out, leaving minimal thread engagement.

If the adjuster is threaded out near its limit and the correct free play cannot be obtained, turn the adjuster all the way in and back out one turn.

Tighten the lock nut and make a major adjustment as described as follow.

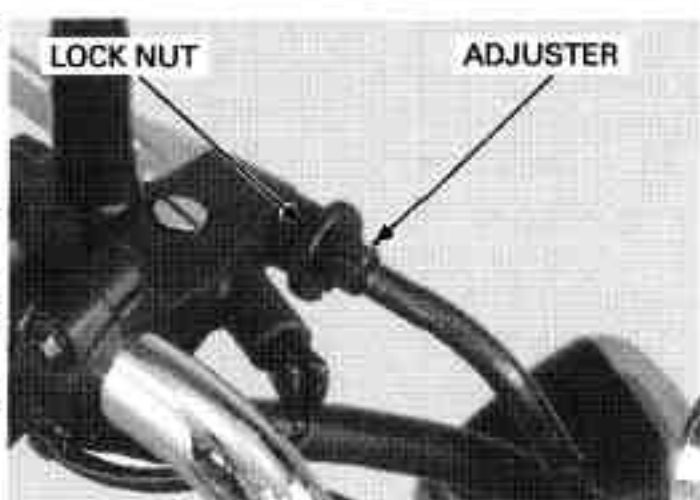

Major adjustments are performed at the clutch arm. Loosen the lock nut and turn the adjusting nut to adjust free play. Hold the adjusting nut securely while tightening the lock nut.

If proper free play cannot be obtained, or the clutch slips during test ride, disassemble and inspect the clutch (page 10-7).

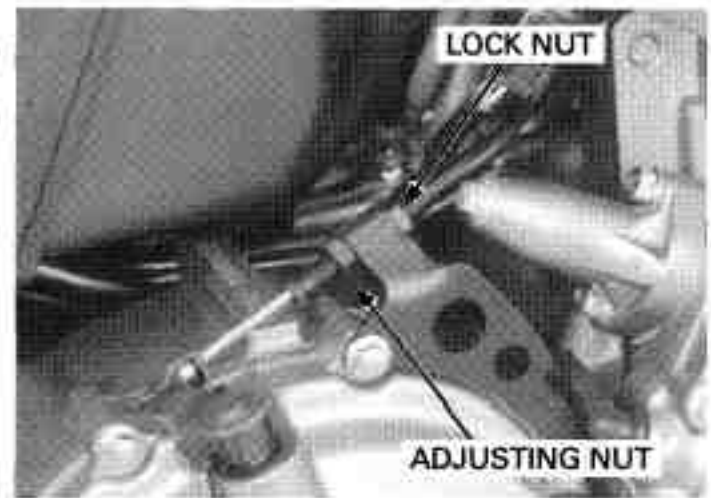

SIDE STAND

Support the motorcycle on a level surface.

Check the side stand spring for damage or loss of tension.

Check the side stand assembly for freedom of movement and lubricate the side stand pivot if necessary.

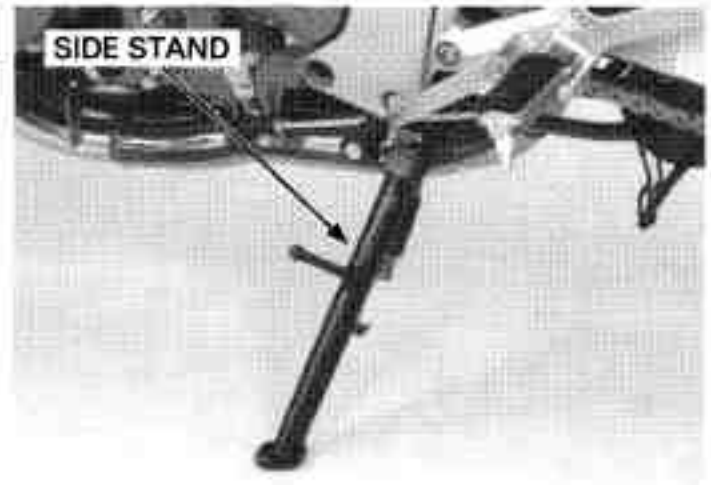

Check the side stand ignition cut-off system:

- Sit astride the motorcycle and raise the side stand.
- Start the engine with the transmission in neutral, then shift the transmission into gear, with the clutch lever squeezed.
- Move the side stand full down.
- The engine should stop as the side stand is lowered.

If there is a problem with the system, check the side stand switch.

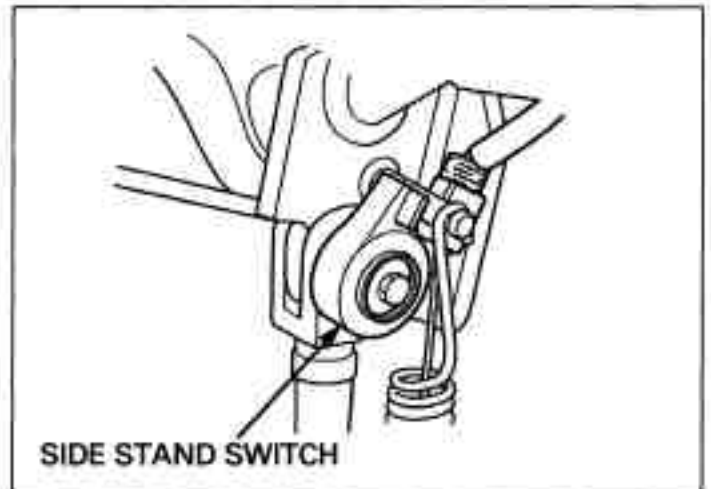

SUSPENSION

FRONT SUSPENSION INSPECTION

Check the action of the forks by operating the front brakes and compressing the front suspension several times.

Check the entire assembly for signs of leaks, damage or loose fasteners.

Replace damaged components which cannot be repaired.

Tighten all nuts and bolts.

Refer to the fork service (page 14-21).



REAR SUSPENSION INSPECTION

Support the motorcycle using a hoist or equivalent and raise the rear wheel off the ground.

Hold the swingarm and move the rear wheel sideways with force to see if the wheel bearings are worn.

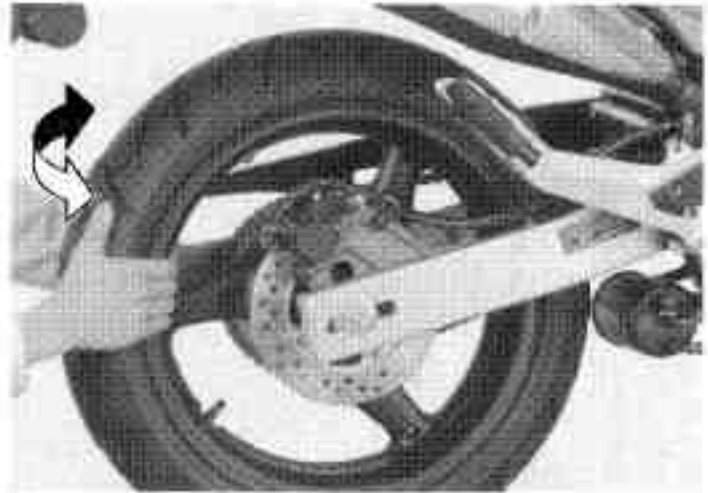

Check for worn swingarm bearings by grabbing the rear swingarm and attempting to move the swingarm side to side.
Replace the bearings if any looseness is noted.



Check the action of the shock absorber by compressing it several times.
Check the entire shock absorber assembly for signs of leaks, damage or loose fasteners.
Replace damaged components which cannot be repaired.
Tighten all nuts and bolts.

Refer to the shock absorber service (page 15-13).

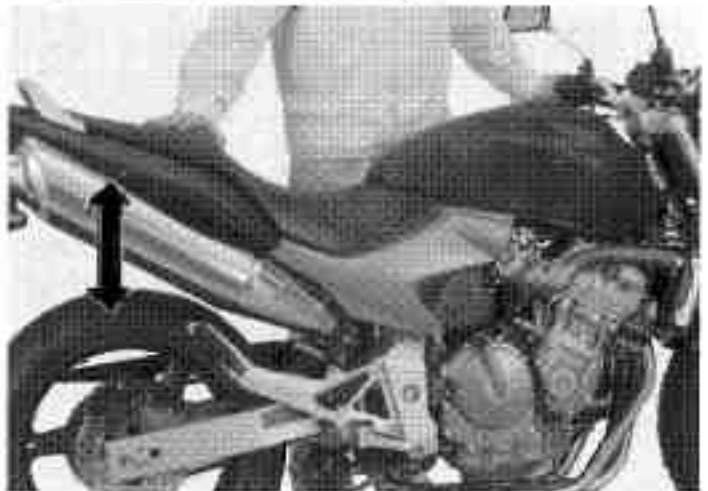

NUTS, BOLTS, FASTENERS

Check that all chassis nuts and bolts are tightened to their correct torque values (page 1-13).
Check that all safety clips, hose clamps and cable stays are in place and properly secured.

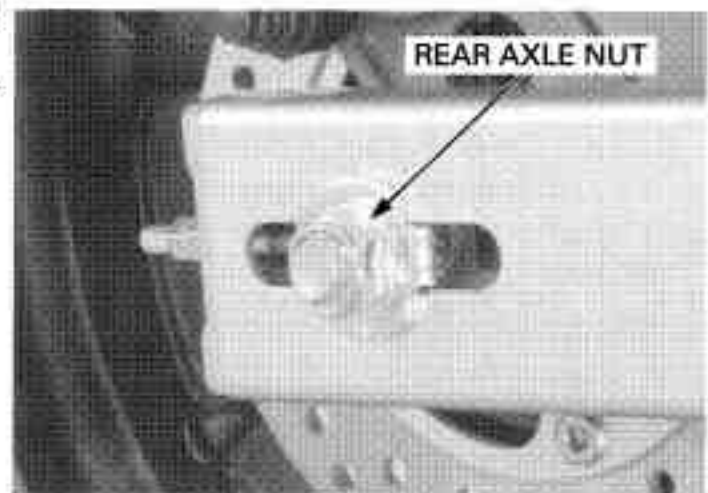

WHEELS/TIRES

Tire pressure should be checked when the tires are COLD.

RECOMMENDED TIRE PRESSURE AND TIRE SIZE:

		FRONT	REAR
Tire pressure kPa (kgf/cm ² , psi)		250 (2.50, 36)	290 (2.90, 42)
Tire size		120/70 ZR 17M/C (58W)	180/55 ZR 17M/C (73W)
Tire brand	Bridgestone	BT-56F RADIAL N	BT-56R RADIAL G
	Michelin	Pilot ROAD S	Pilot ROAD S

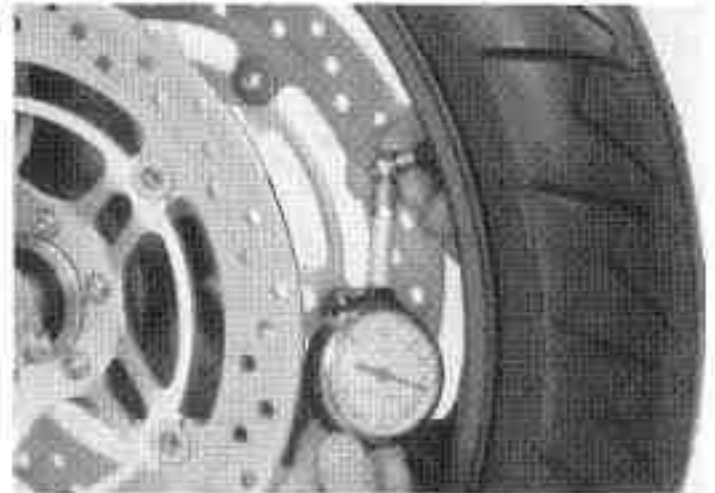

Check the tires for cuts, embedded nails, or other damage.

Check the front wheel (page 14-15) and rear wheel (page 15-6) for trueness.

Measure the tread depth at the center of the tires. Replace the tires when the tread depth reaches the following limits.

MINIMUM TREAD DEPTH:

FRONT: 1.5 mm (0.06 in)

REAR: 2.0 mm (0.08 in)



STEERING HEAD BEARINGS

Check that the control cables do not interfere with handlebar rotation.

Support the motorcycle using a safety stand or hoist securely and raise the front wheel off the ground. Check that the handlebar moves freely from side to side.

If the handlebar moves unevenly, binds, or has vertical movement, inspect the steering head bearings (page 14-41).



5. LUBRICATION SYSTEM

LUBRICATION SYSTEM DIAGRAM	5-2	OIL STRAINER/PRESSURE RELIEF VALVE ..	5-6
SERVICE INFORMATION	5-3	OIL PUMP.....	5-8
TROUBLE SHOOTING	5-4	OIL COOLER.....	5-14
OIL PRESSURE INSPECTION.....	5-5		

LUBRICATION SYSTEM

LUBRICATION SYSTEM DIAGRAM

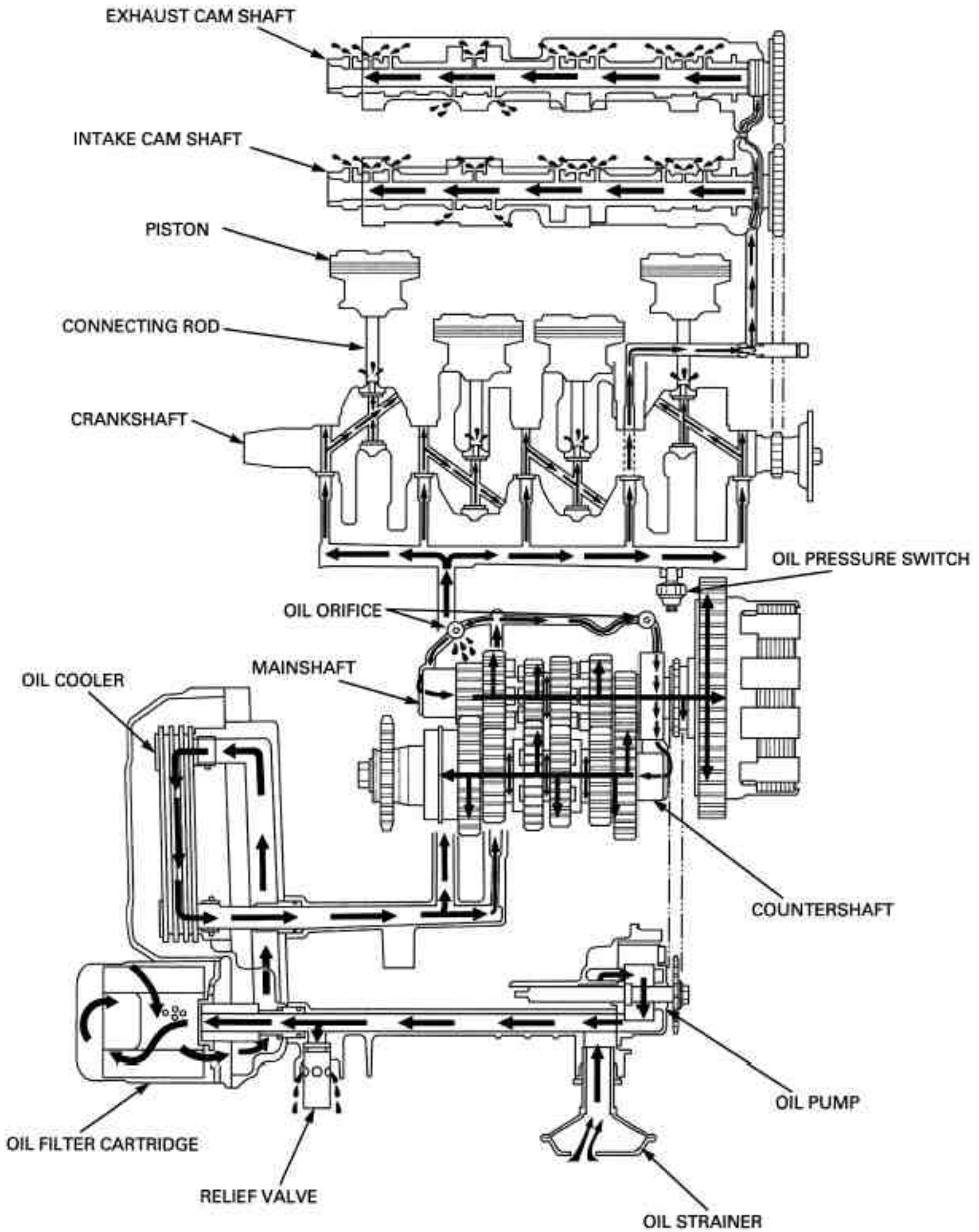

SERVICE INFORMATION

GENERAL

▲ CAUTION

Used engine oil may cause skin cancer if repeatedly left in contact with the skin for prolonged periods. Although this is unlikely unless you handle used oil on a daily basis, it is still advisable to thoroughly wash your hands with soap and water as soon as possible after handling used oil.

- The oil pump can be serviced with the engine installed in the frame.
- The service procedures in this section must be performed with the engine oil drained.
- When removing and installing the oil pump, use care not to allow dust or dirt to enter the engine.
- If any portion of the oil pump is worn beyond the specified service limits, replace the oil pump as an assembly.
- After the oil pump has been installed, check that there are no oil leaks and that oil pressure is correct.

SPECIFICATIONS

ITEM		STANDARD	SERVICE LIMIT
Engine oil capacity	After draining	3.5 liter (3.7 US qt, 3.1 Imp qt)	-
	After draining/filter change	3.8 liter (4.0 US qt, 3.3 Imp qt)	-
	After disassembly	4.2 liter (4.4 US qt, 3.7 Imp qt)	-
Recommended engine oil		Pro Honda GN4 or HP4 (Without molybdenum additives) 4-stroke oil or equivalent motor oil API service classification SG or Higher JASO T 903 standard: MA Viscosity: SAE 10W-40	-
Oil pressure at oil pressure switch		490 kPa (5.0 kgf/cm ² , 71 psi) at 6,000 rpm/(80°C/176°F)	-
Oil pump rotor	Tip clearance	0.15 (0.006)	0.20 (0.008)
	Body clearance	0.15 – 0.22 (0.006 – 0.009)	0.35 (0.014)
	Side clearance	0.02 – 0.07 (0.001 – 0.003)	0.10 (0.004)
Oil pump drive sprocket collar O.D.		34.050 – 34.075 (1.3405 – 1.3415)	34.03 (1.340)
Oil pump drive sprocket I.D.		35.025 – 35.075 (1.3789 – 1.3809)	35.10 (1.382)

TORQUE VALUES

Engine oil drain bolt	29 N·m (3.0 kgf·m, 22 lbf·ft)	
Engine oil filter cartridge	25 N·m (2.5 kgf·m, 18 lbf·ft)	Apply oil to the threads and flange surface
Oil filter boss	18 N·m (1.8 kgf·m, 13 lbf·ft)	Apply locking agent to the threads
Oil pump driven sprocket bolt	15 N·m (1.5 kgf·m, 11 lbf·ft)	Apply locking agent to the threads
Oil pump assembly bolt	7.8 N·m (0.80 kgf·m, 5.8 lbf·ft)	CT bolt
Oil cooler sealing bolt	49 N·m (5.0 kgf·m, 36 lbf·ft)	Apply locking agent to the threads
Oil pressure switch	12 N·m (1.2 kgf·m, 9 lbf·ft)	Apply sealant to the threads
Oil pressure switch terminal screw	2.0 N·m (0.20 kgf·m, 1.4 lbf·ft)	

LUBRICATION SYSTEM

TOOLS

<p>Oil pressure gauge 07506-3000001</p>  <p>or equivalent commercially available in U.S.A.</p>	<p>Oil pressure gauge attachment 07510-4220100</p>  <p>or equivalent commercially available in U.S.A.</p>	<p>Oil filter wrench 07HAA-PJ70101</p>  <p>or 07HAA-PJ70100 (U.S.A. only)</p>
---	---	--

TROUBLE SHOOTING

Oil level too low

- Oil consumption
- External oil leak
- Worn piston rings
- Improperly installed piston rings
- Worn cylinders
- Worn stem seals
- Worn valve guide

Low oil pressure

- Oil level low
- Clogged oil strainer
- Internal oil leak
- Incorrect oil being used

No oil pressure

- Oil level too low
- Oil pressure relief valve stuck open
- Broken oil pump drive chain
- Broken oil pump drive or driven sprocket
- Damaged oil pump
- Internal oil leak

High oil pressure

- Oil pressure relief valve stuck closed
- Clogged oil filter, gallery or metering orifice
- Incorrect oil being used

Oil contamination

- Oil or filter not changed often enough
- Worn piston rings

Oil emulsification

- Blown cylinder head gasket
- Leaky coolant passage
- Entry of water

OIL PRESSURE INSPECTION

If the oil pressure indicator light remains on, check the indicator system before checking the oil pressure.

Check the oil level (page 4-14).
Remove the bolts and clutch cable guide.

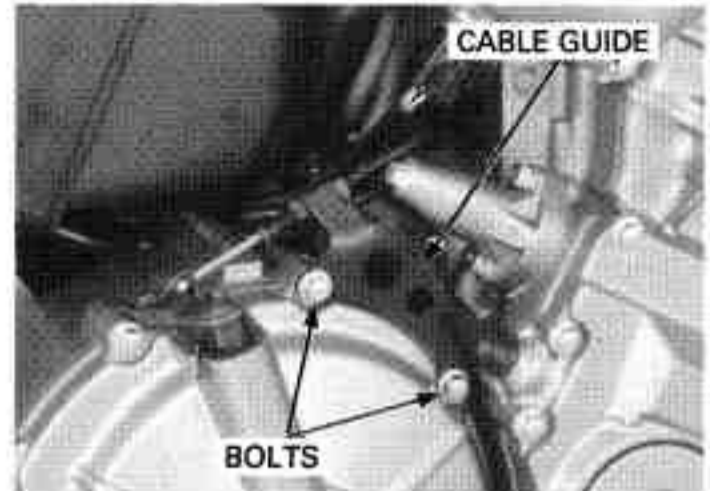

Remove the rubber cap.
Remove the oil pressure terminal switch screw and terminal eyelet.
Remove the oil pressure switch.

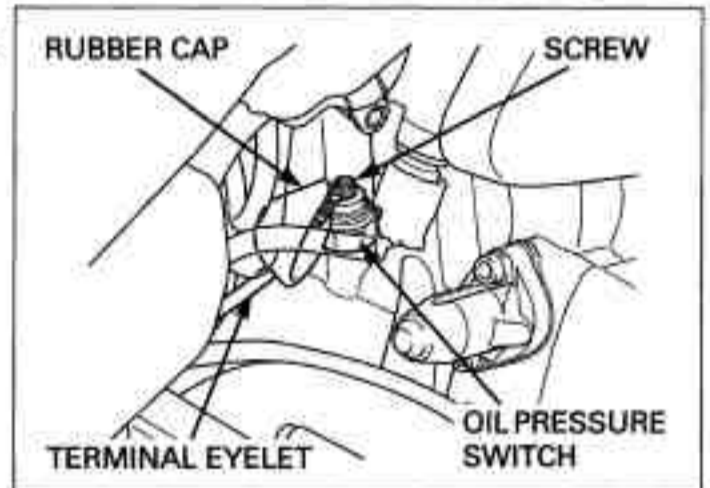

Connect an oil pressure gauge and attachment to the oil pressure switch hole.

- TOOLS:**
- Oil pressure gauge **07506-3000001 or equivalent commercially available in U.S.A.**
 - Oil pressure gauge attachment **07510-4220100 or equivalent commercially available in U.S.A.**

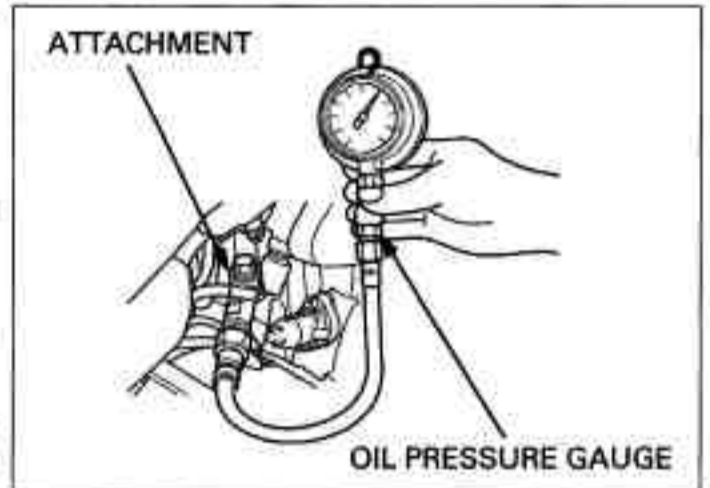

Warm up the engine to normal operating temperature (approximately 80°C/176°F) and increase the rpm to 6,000 rpm and read the oil pressure.

OIL PRESSURE:
490 kPa (5.0 kgf/cm², 71 psi) at 6,000 rpm/ (80°C/176°F)

Stop the engine and remove the tools.
Apply a sealant to the oil pressure switch threads as shown.
Install and tighten the oil pressure switch to the specified torque.

TORQUE: 12 N-m (1.2 kgf-m, 9 lbf-ft)

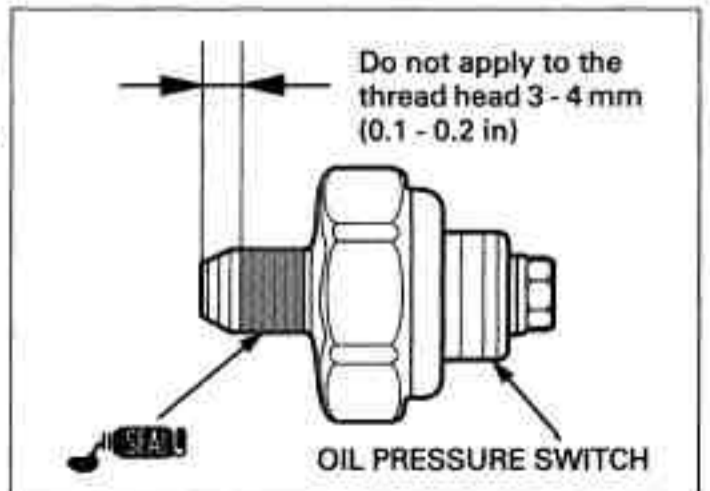

LUBRICATION SYSTEM

Connect the oil pressure switch wire and tighten the oil pressure switch terminal screw to the specified torque.

TORQUE: 2.0 N-m (0.20 kgf-m, 1.4 lbf-ft)

Instal the rubber cap securely.

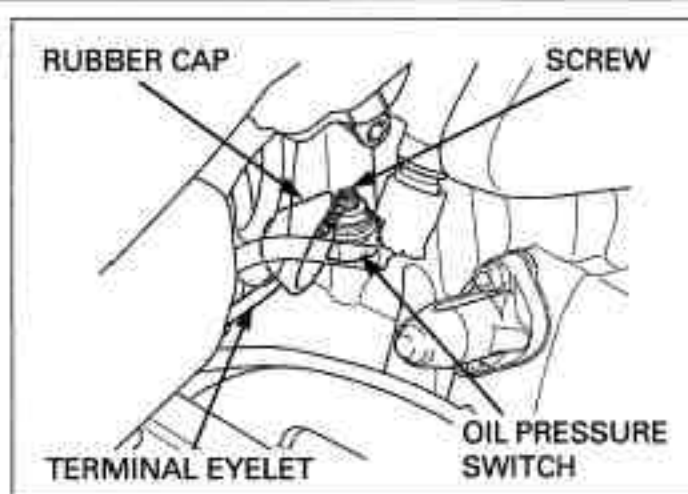

Instal the clutch cable guide and tighten the bolts securely.

Start the engine.

Check that the oil pressure indicator goes out after one or two seconds. If the oil pressure indicator stays on, stop the engine immediately and determine the cause.

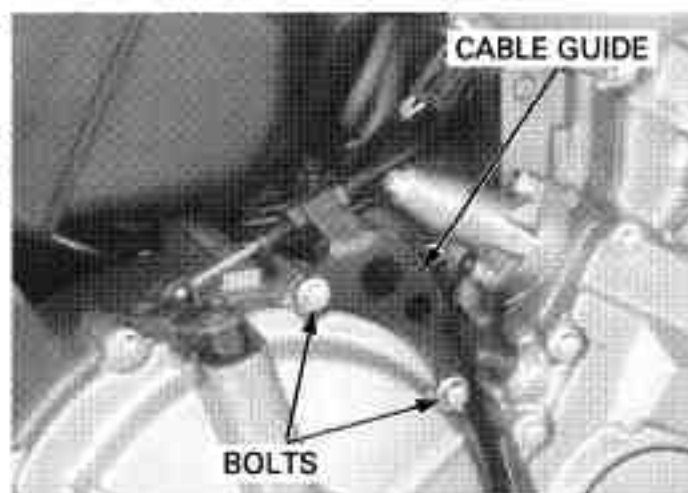

OIL STRAINER/PRESSURE RELIEF VALVE

REMOVAL

Drain the engine oil (page 4-15).
Remove the exhaust pipe (page 3-10).
Remove the bolts and oil pan.

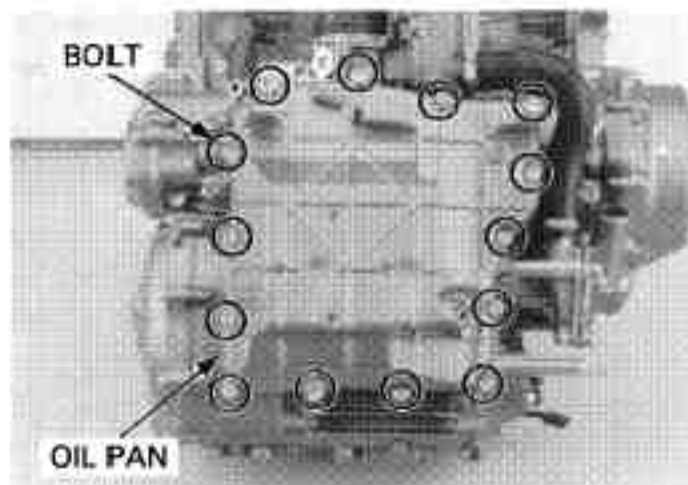

Remove the pressure relief valve and O-ring.
Remove the oil strainer and packing.

Check the oil strainer for damage or clogging.
Clean the oil strainer screen.



INSPECTION

Check the operation of the pressure relief valve by pushing on the piston.

Disassemble the relief valve by removing the snap ring.

Inspect the piston for wear, sticking or damage.
Inspect the spring for weakness or damage.

Assemble the relief valve in the reverse order of disassembly.

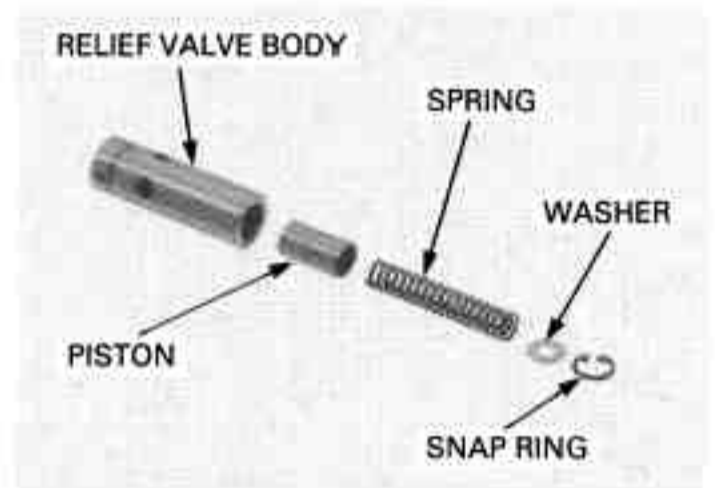

INSTALLATION

Apply oil to the new O-ring and install it to the relief valve groove.

Install the relief valve into the crankcase.

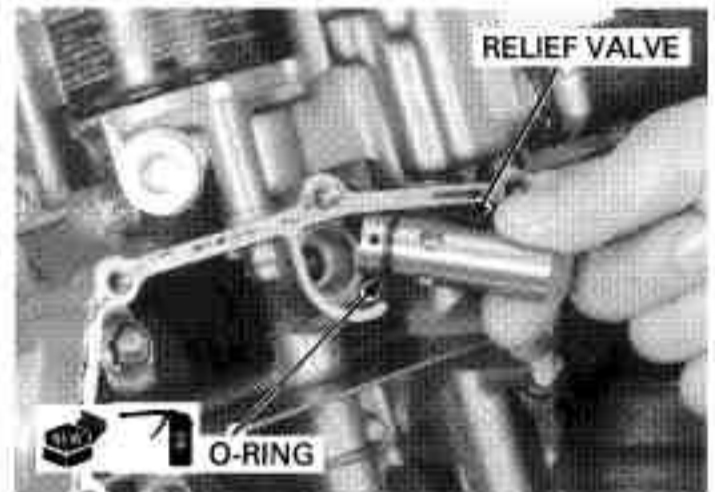

Apply oil to the new packing and install it onto the oil strainer.

Install the oil strainer into the crankcase while aligning its boss with the groove of the crankcase.

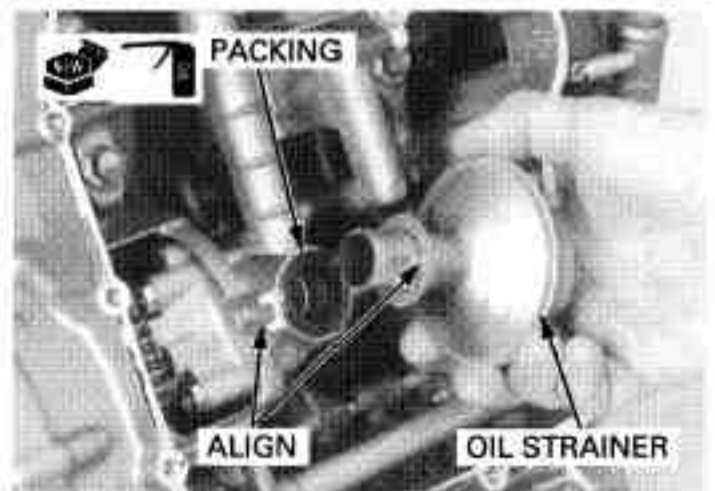

LUBRICATION SYSTEM

Clean the oil pan mating surface thoroughly.

Do not apply sealant more than necessary.

Apply Three Bond 1207B or an equivalent to the mating surface.

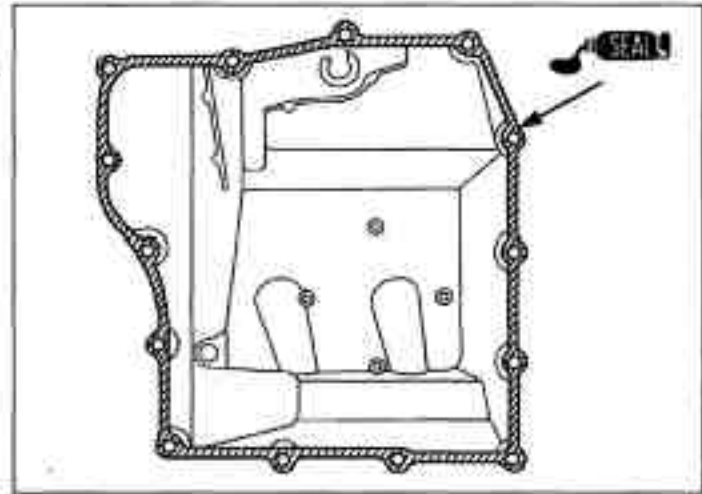

Carefully install the oil pan onto the lower crankcase.

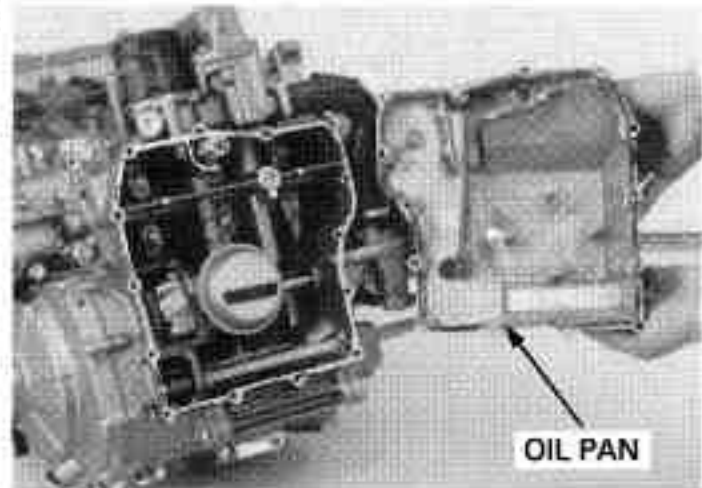

Install and tighten the bolts in a crisscross pattern in 2 - 3 steps.

Install the exhaust pipe (page 3-10).

Fill the crankcase with recommended oil (page 4-14).

After installation, check that there are no oil leaks.

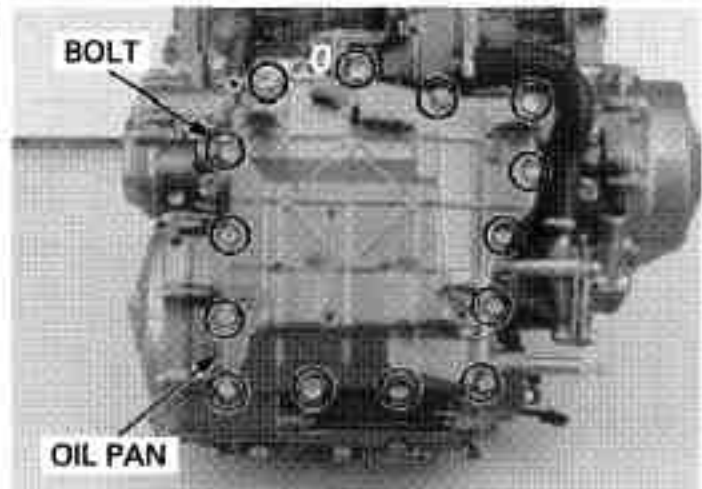

OIL PUMP

REMOVAL

Remove the oil strainer and pressure relief valve (page 5-6).

Remove the clutch assembly (page 10-7).

Remove the bolt/washer, then remove the oil pump drive/driven sprocket and drive chain as an assembly.

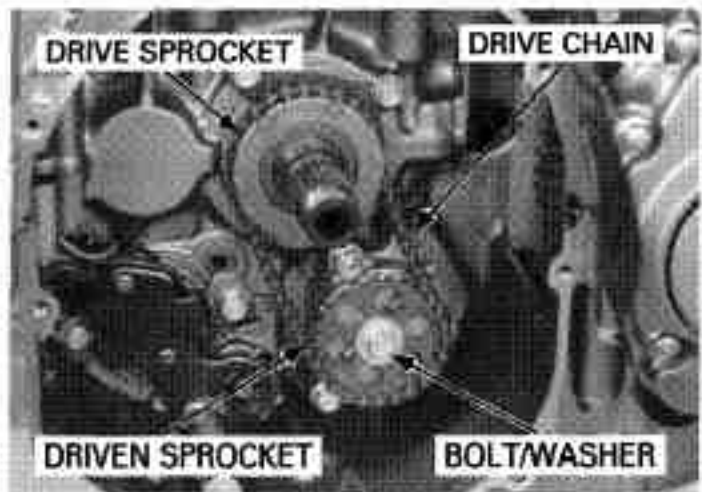

Remove the drive sprocket collar from the mainshaft.

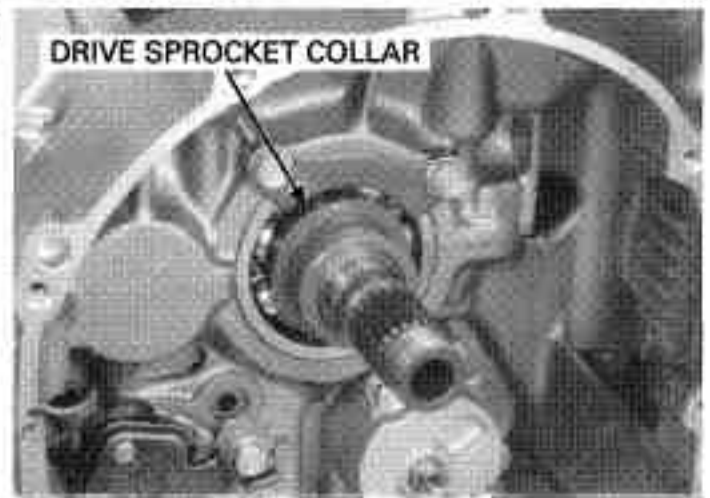

Remove the bolts and oil pump assembly.

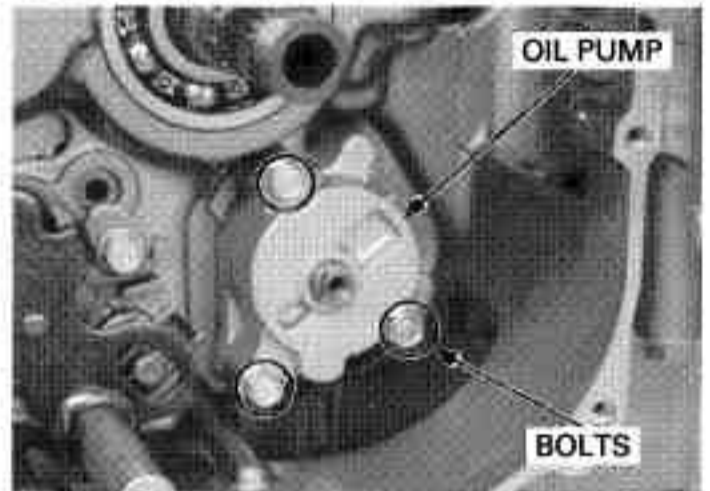

DISASSEMBLY

Remove the oil pump assembly bolt.

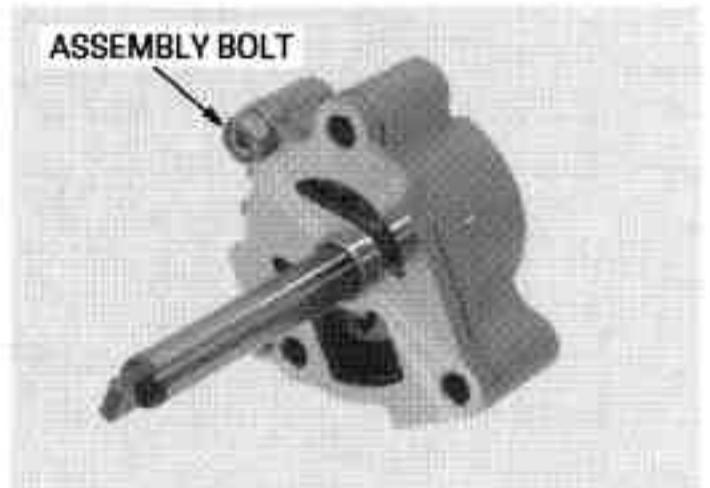

Remove the oil pump cover and dowel pin.

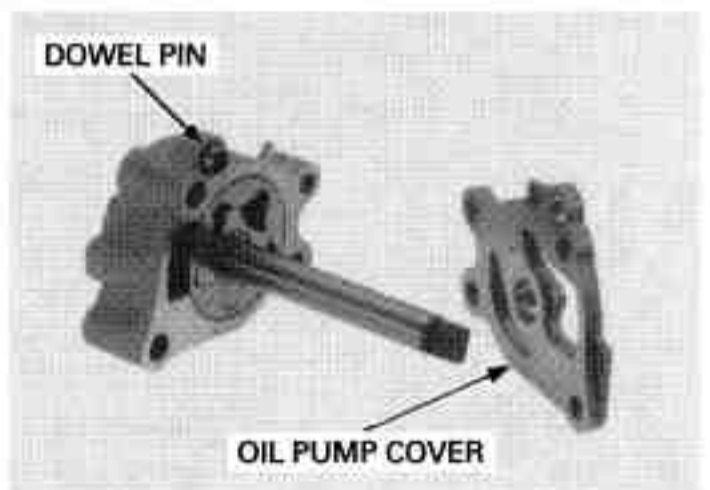

LUBRICATION SYSTEM

Remove the thrust washer, drive pin, oil pump shaft, outer rotor and inner rotor from the oil pump body.

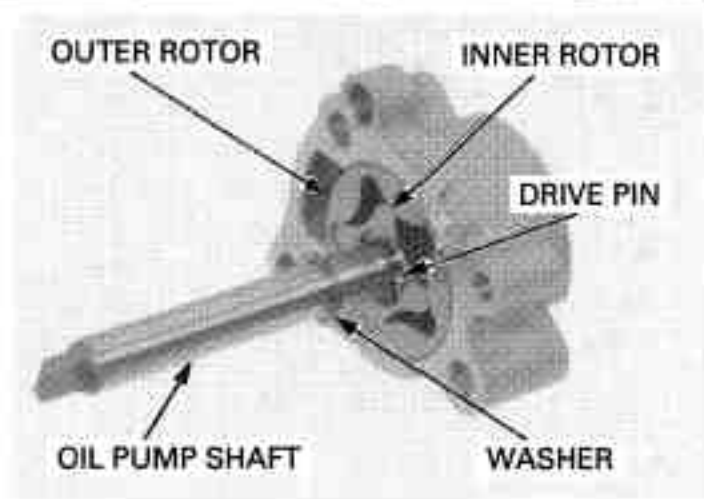

INSPECTION

If any portion of the oil pump is worn beyond the service limit, replace the oil pump as an assembly.

Temporarily install the oil pump shaft. Install the outer and inner rotors into the oil pump body.

Measure the rotor tip clearance.

SERVICE LIMIT: 0.20 mm (0.008 in)

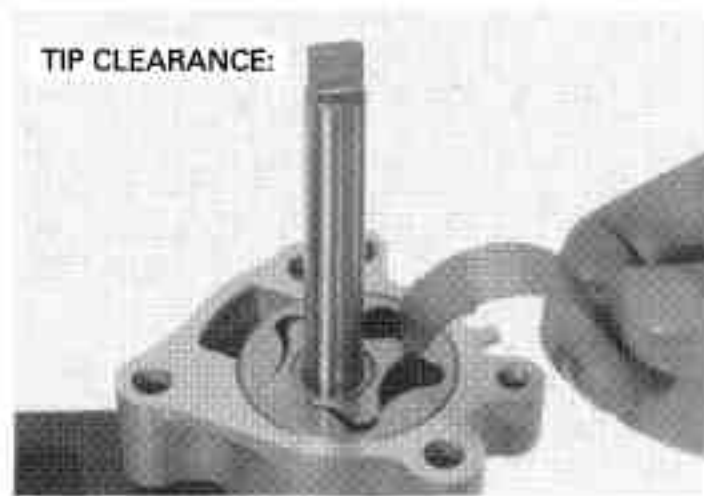

Measure the pump body clearance.

SERVICE LIMIT: 0.35 mm (0.014 in)

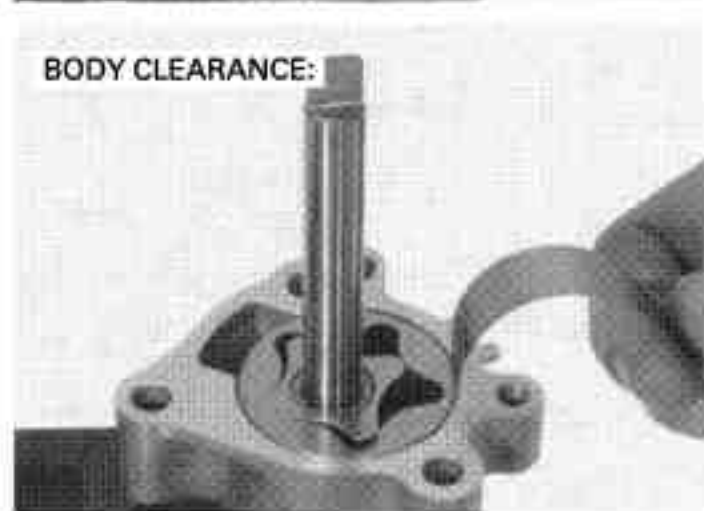

Measure the side clearance using a straight edge and feeler gauge.

SERVICE LIMIT: 0.10 mm (0.004 in)

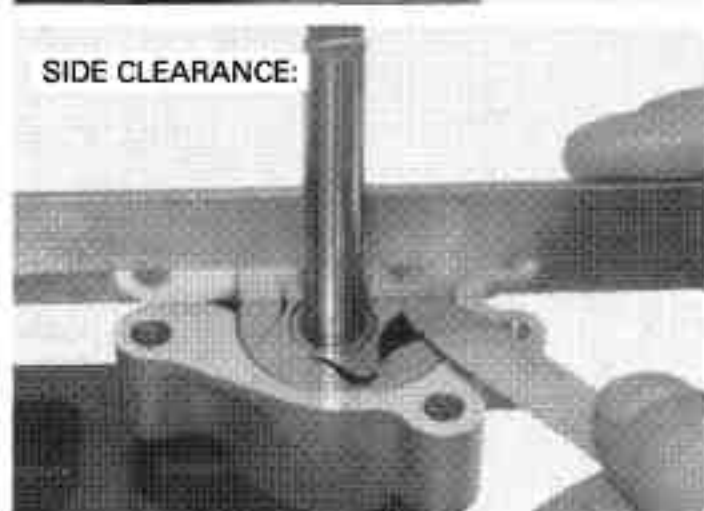

Measure the oil pump drive sprocket collar O.D.

SERVICE LIMIT: 34.03 mm (1.340 in)

Measure the oil pump drive sprocket I.D.

SERVICE LIMIT: 35.10 mm (1.382 in)

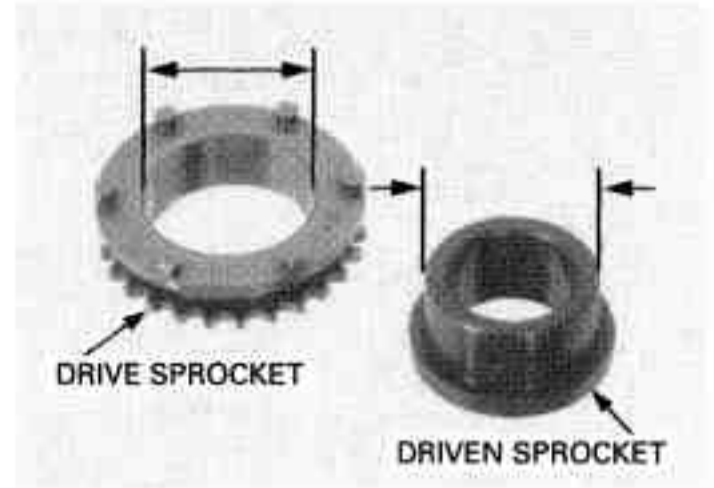

ASSEMBLY

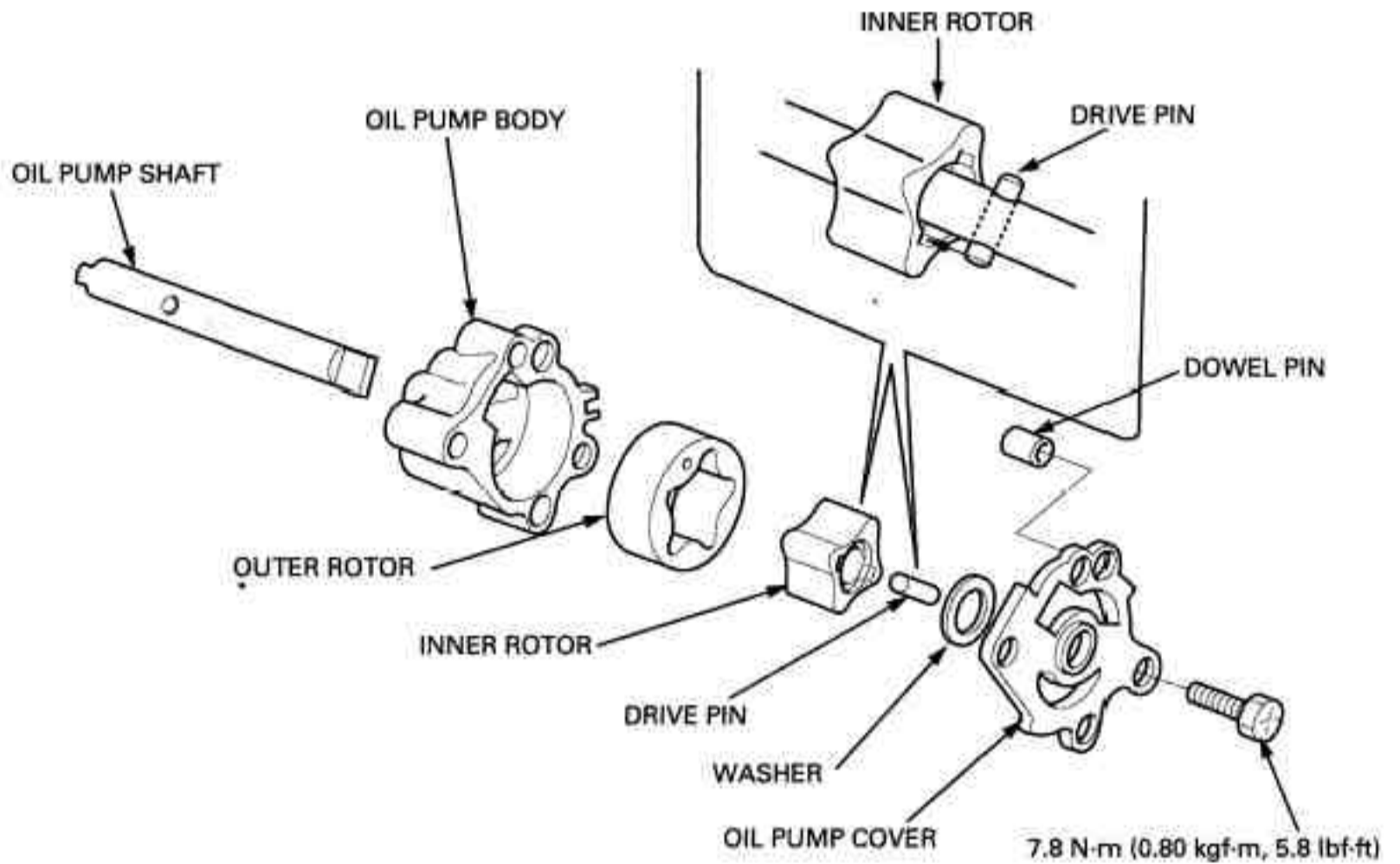

Install the outer rotor into the oil pump body.
Install the inner rotor into the outer rotor with its drive pin groove facing the oil pump cover.

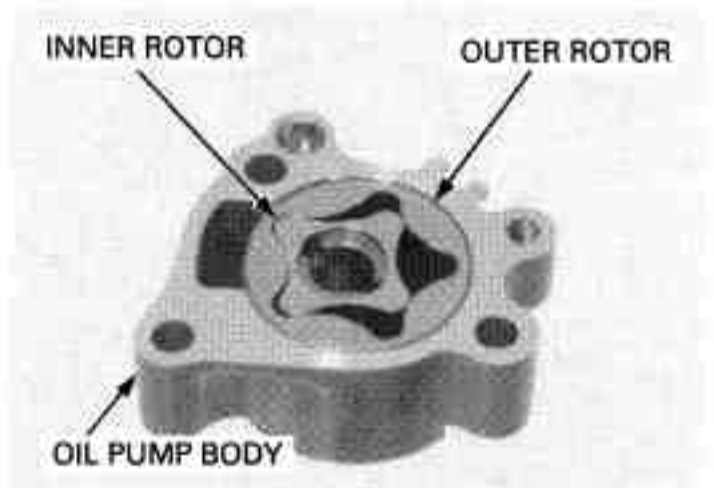

LUBRICATION SYSTEM

Install the oil pump shaft through the inner rotor and oil pump body.
Install the drive pin into the hole in the pump shaft and align the pin with the groove in the inner rotor as shown.
Install the thrust washer.

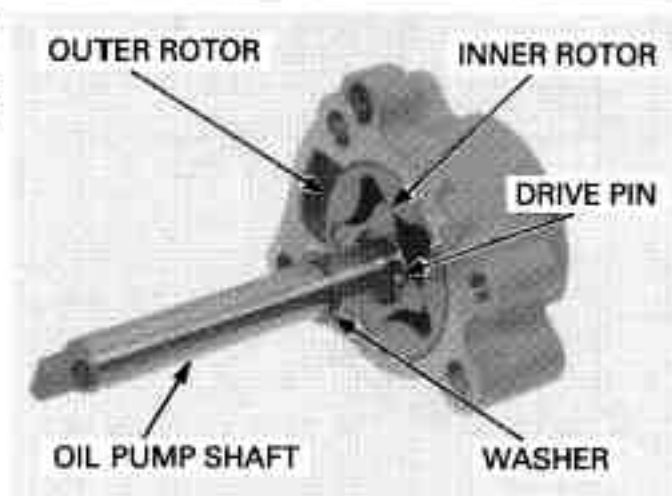

Install the dowel pin.
Install the oil pump cover.

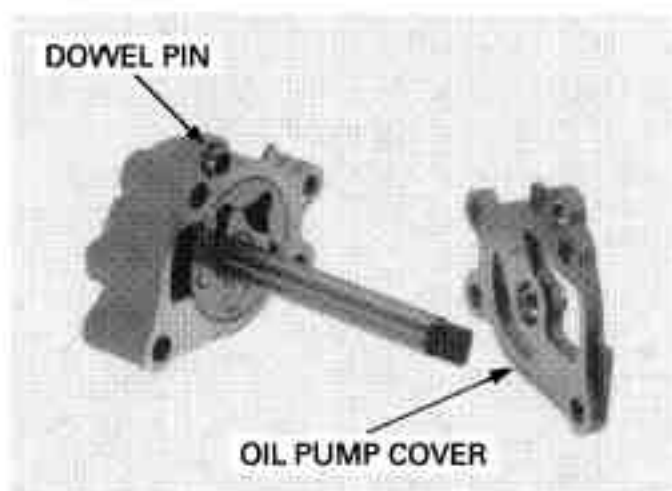

Install and tighten the bolt to the specified torque.

TORQUE: 7.8 N·m (0.80 kgf·m, 5.8 lbf·ft)

Check the oil pump operation by turning the pump shaft.

If necessary, reassemble the oil pump.

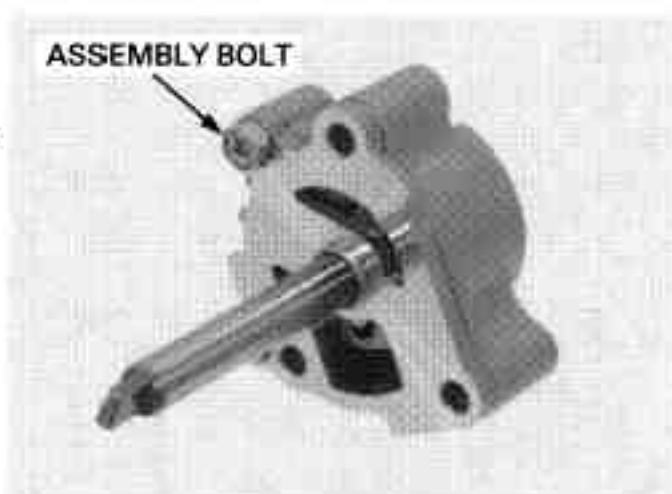

INSTALLATION

Install the oil pump onto the crankcase while aligning the pump shaft lug with the water pump shaft groove by turning the oil pump shaft.

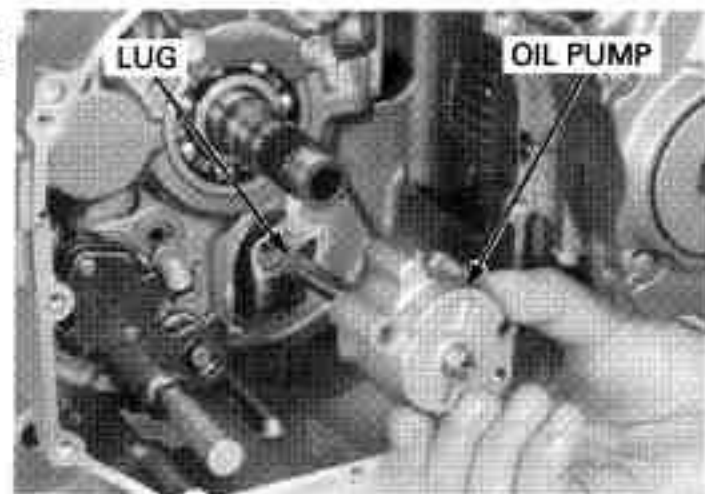

Install and tighten the bolts securely.

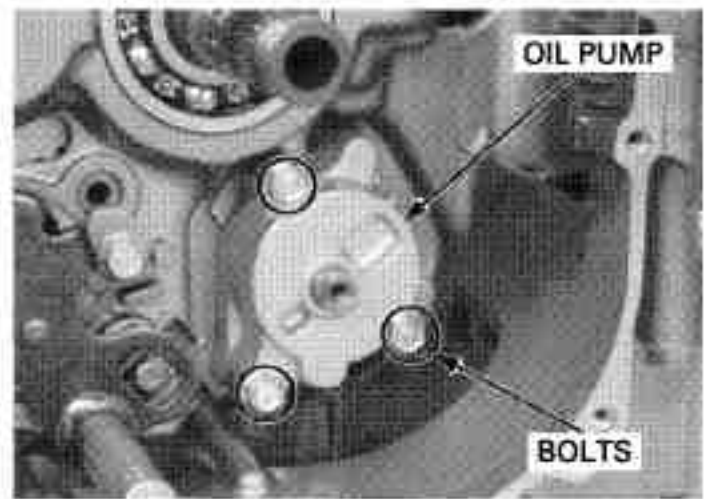

Apply oil to the oil pump drive sprocket collar. Install the drive sprocket collar onto the mainshaft.



Apply oil to the drive sprocket and drive chain.

Align the flat surfaces of the driven sprocket with the oil pump drive shaft end.

Install the drive/driven sprocket and drive chain as an assembly with the "OUT" mark on the driven sprocket facing out.

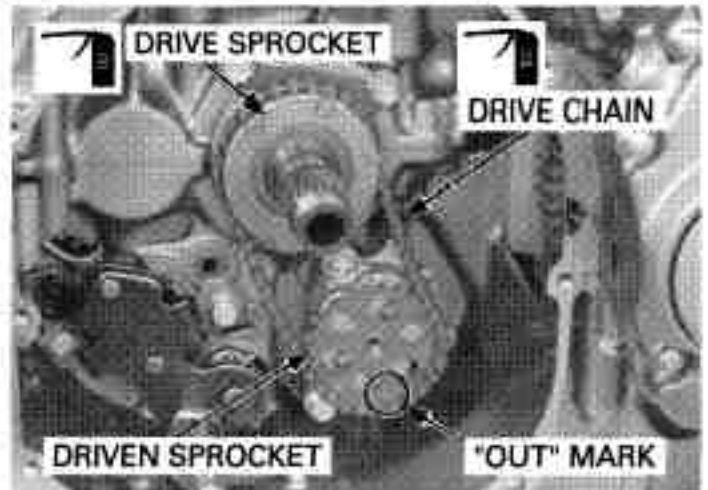

Apply a locking agent to the oil pump driven sprocket bolt threads.

Install and tighten the driven sprocket bolt/washer to the specified torque.

TORQUE: 15 N·m (1.5 kgf·m, 11 lbf·ft)

Install the clutch assembly (page 10-12)
After installation, fill the crankcase with recommended oil and check that there is no oil leaks.
Check the oil pressure (page 5-5).



OIL COOLER

REMOVAL

Remove the exhaust pipe (page 3-10).
Drain the engine oil and remove the oil filter cartridge (page 4-15)
Drain the coolant from the system (page 7-7).
Loosen the hose band screw and disconnect the oil cooler water hose from the cooler.

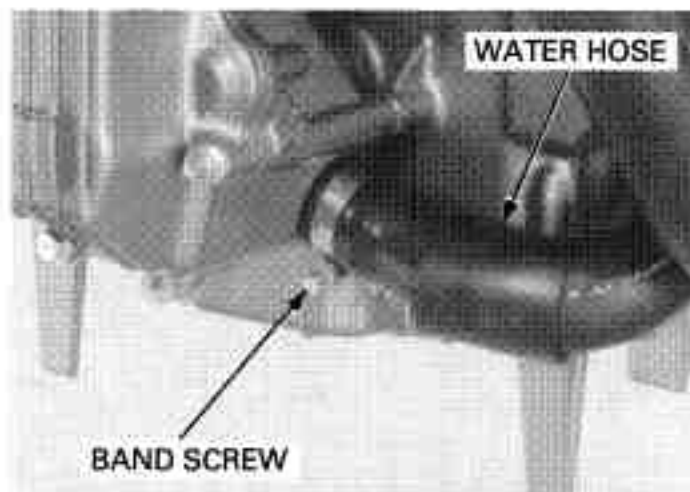

Remove the bolts and oil cooler.

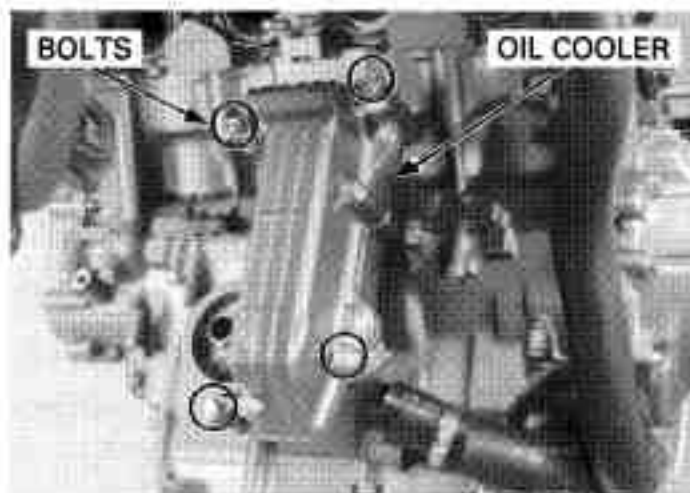

Remove the joint collars/O-rings from the crankcase.

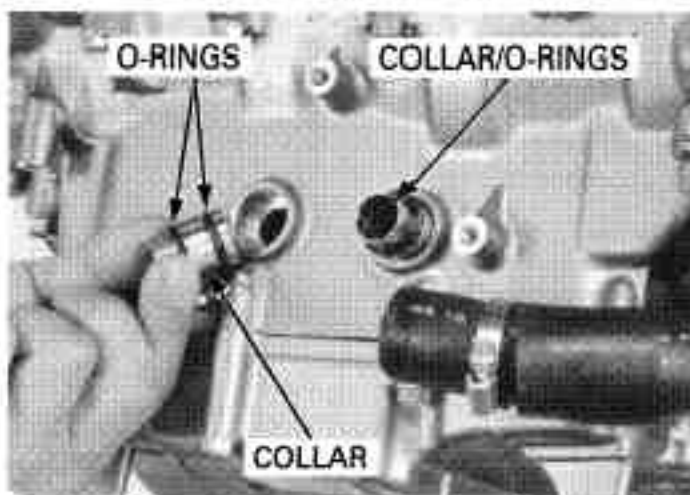

Remove the O-ring from the oil cooler.



DISASSEMBLY

Remove the oil cooler cover bolts and sealing washer.
Remove the oil cooler cover and O-ring.

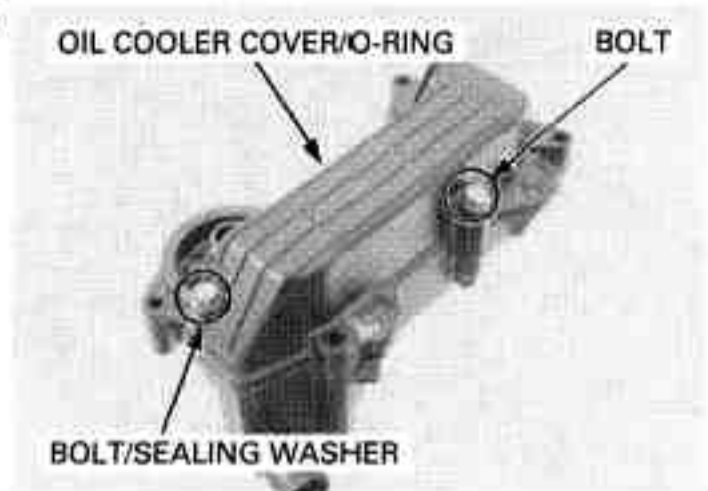

Remove the bolts, washers and oil cooler.

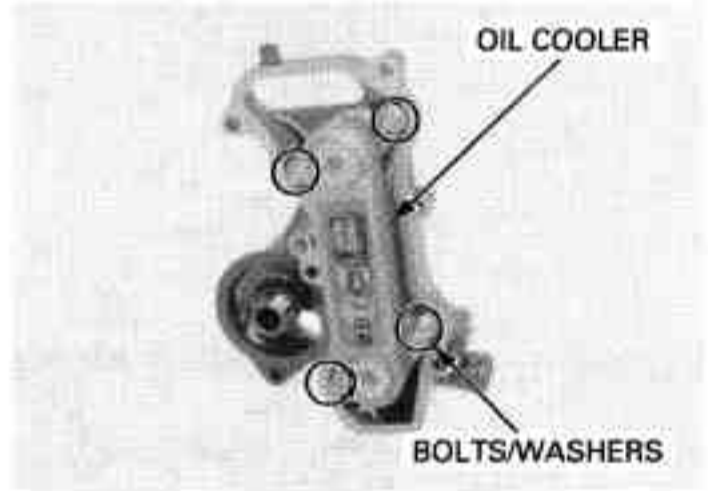

Remove the O-rings and joint collars from the oil cooler base.

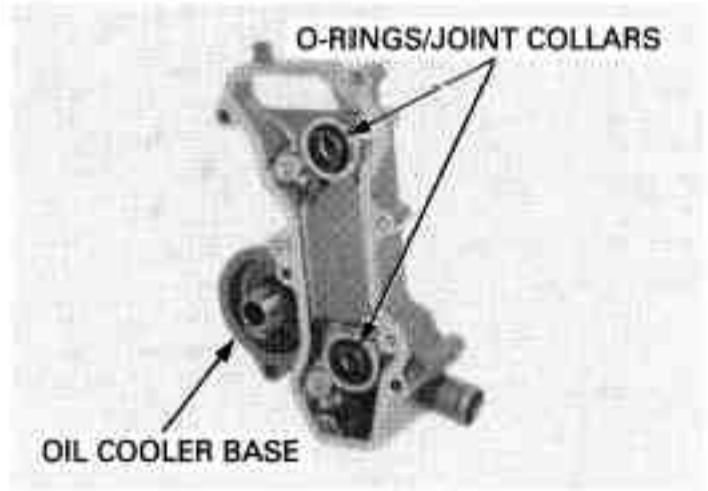

LUBRICATION SYSTEM

ASSEMBLY

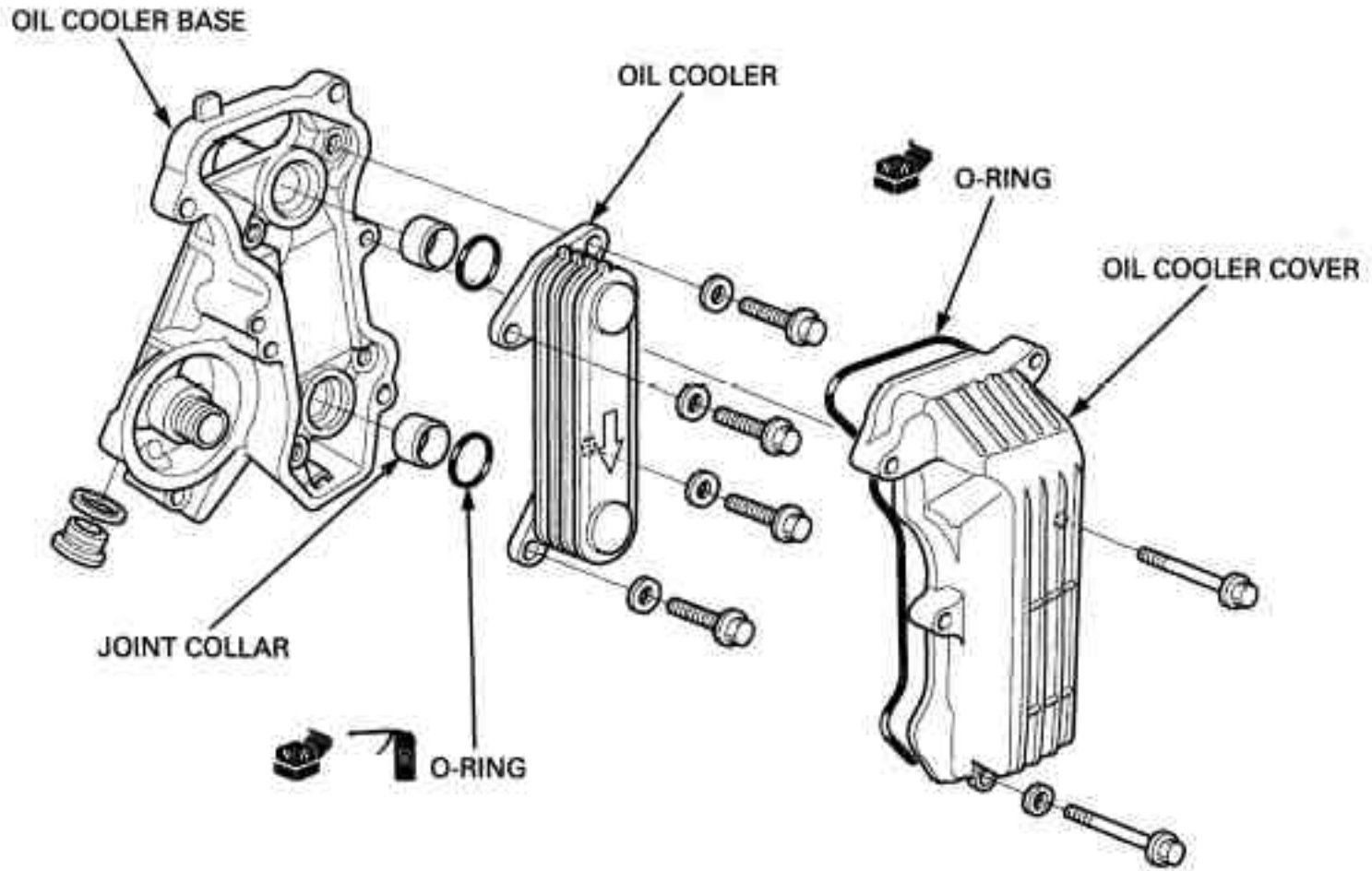

Install the joint collars into the oil cooler base holes. Apply clean engine oil to the new O-rings and install them into the oil cooler base.

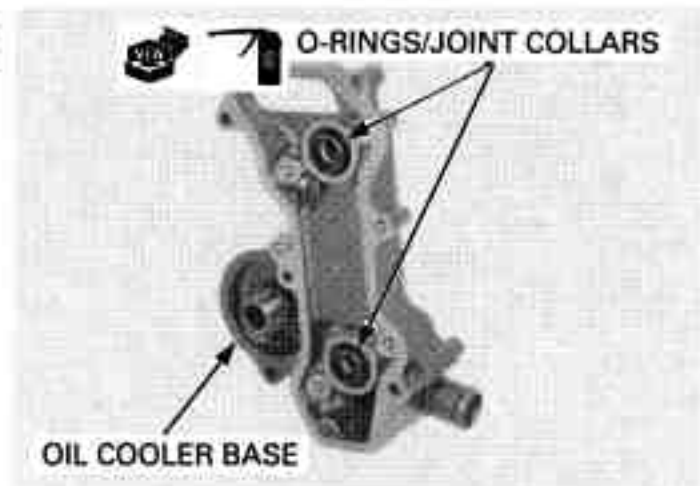

Install the oil cooler with its arrow mark facing down. Install the washers and bolts, then tighten the bolts securely.

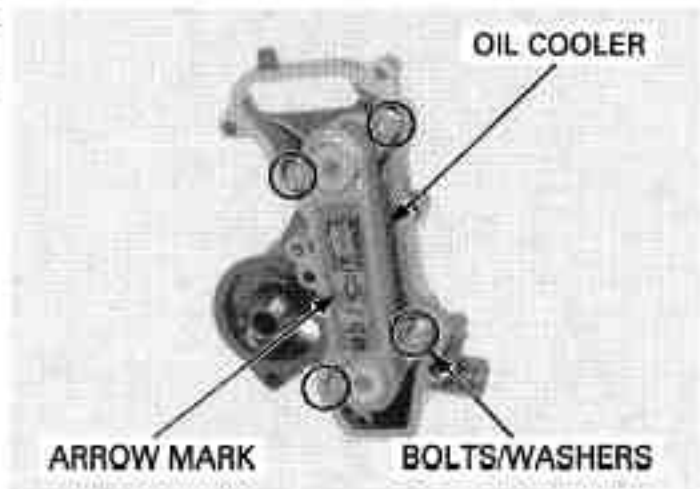

Instal a new O-ring to the oil cooler case groove.



Assemble the oil cooler case and base, then install the sealing washer and bolts. Tighten the bolts securely.



INSTALLATION

Install a new O-ring into the groove of the oil cooler base.

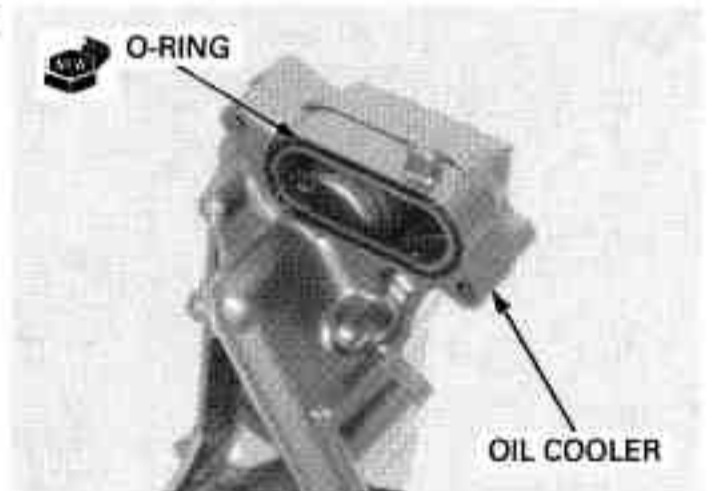

Apply clean engine oil to the new O-rings, and install them onto the joint collars. Install the joint collars to the crankcase with its large O.D. side facing the crankcase.

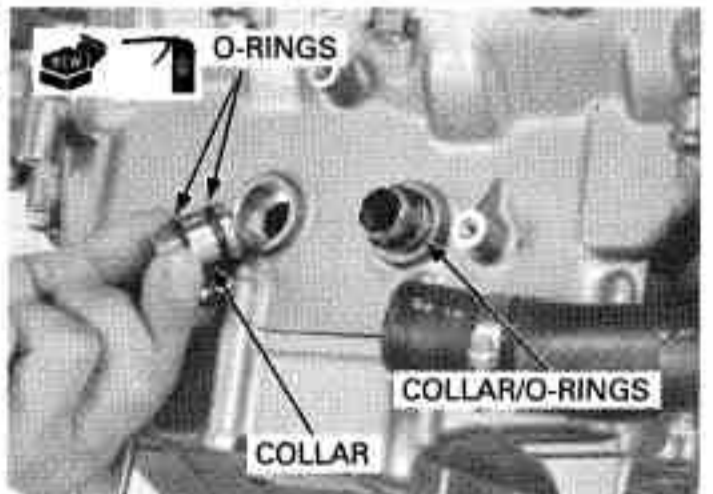

LUBRICATION SYSTEM

Install the oil cooler assembly onto the crankcase.
Install and tighten the oil cooler assembly mounting bolts.

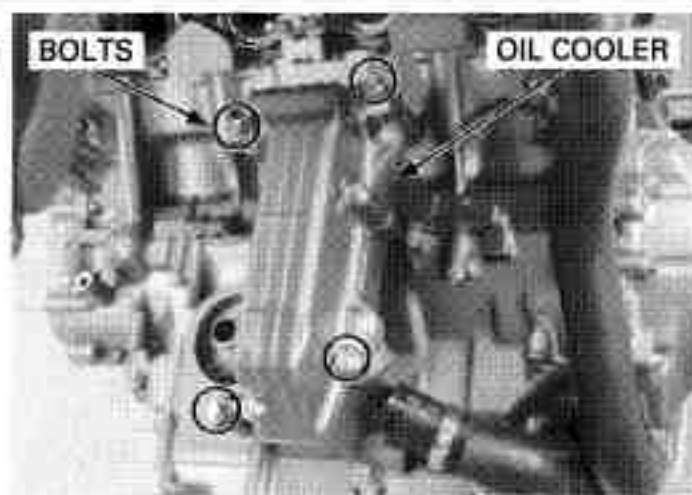

Connect the water hose to the oil cooler and tighten the band screw securely.

Install the exhaust pipe (page 3-10).
Install the oil filter cartridge and fill the crankcase with recommended oil (page 4-15).
Fill the cooling system and bleed air (page 7-7).

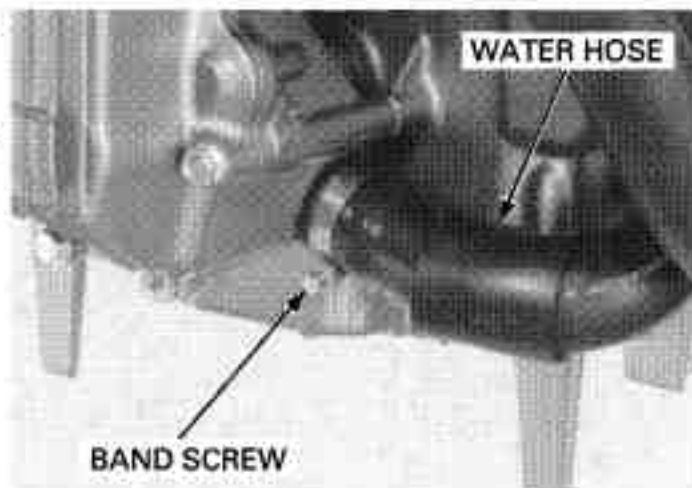

6. FUEL SYSTEM

COMPONENT LOCATION	6-2	CARBURETOR COMBINATION	6-25
SERVICE INFORMATION	6-4	CARBURETOR INSTALLATION	6-34
TROUBLESHOOTING	6-6	PILOT SCREW ADJUSTMENT	6-35
AIR CLEANER HOUSING	6-7	HIGH ALTITUDE ADJUSTMENT	6-36
CARBURETOR REMOVAL	6-10	SECONDARY AIR SUPPLY SYSTEM	6-37
CARBURETOR SEPARATION	6-12	EVAPORATIVE EMISSION CONTROL SYSTEM (California type only)	6-39
CARBURETOR DISASSEMBLY	6-15	FUEL VALVE	6-44
CARBURETOR ASSEMBLY	6-20		

FUEL SYSTEM

COMPONENT LOCATION

'04 model:

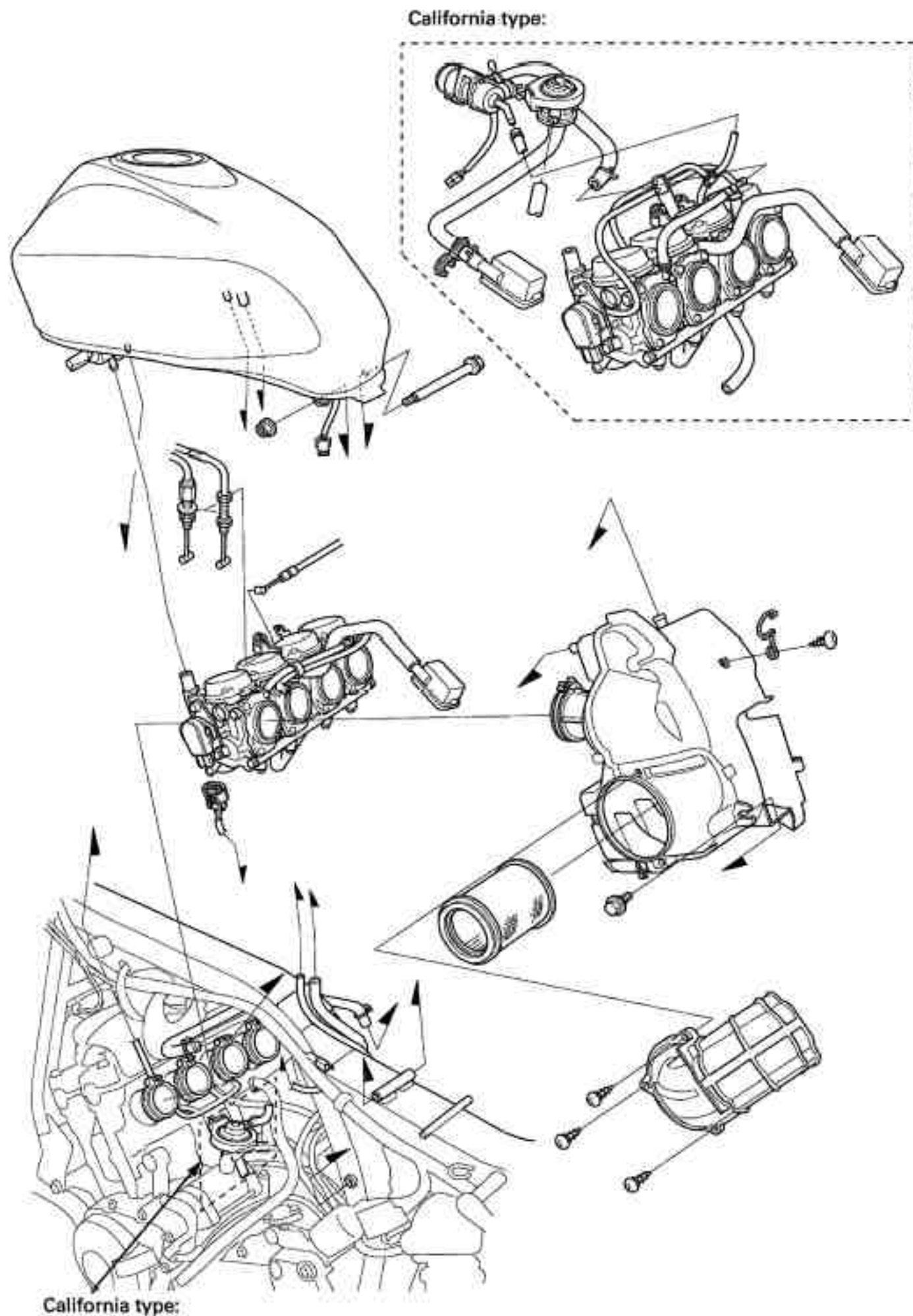

After '04 model:

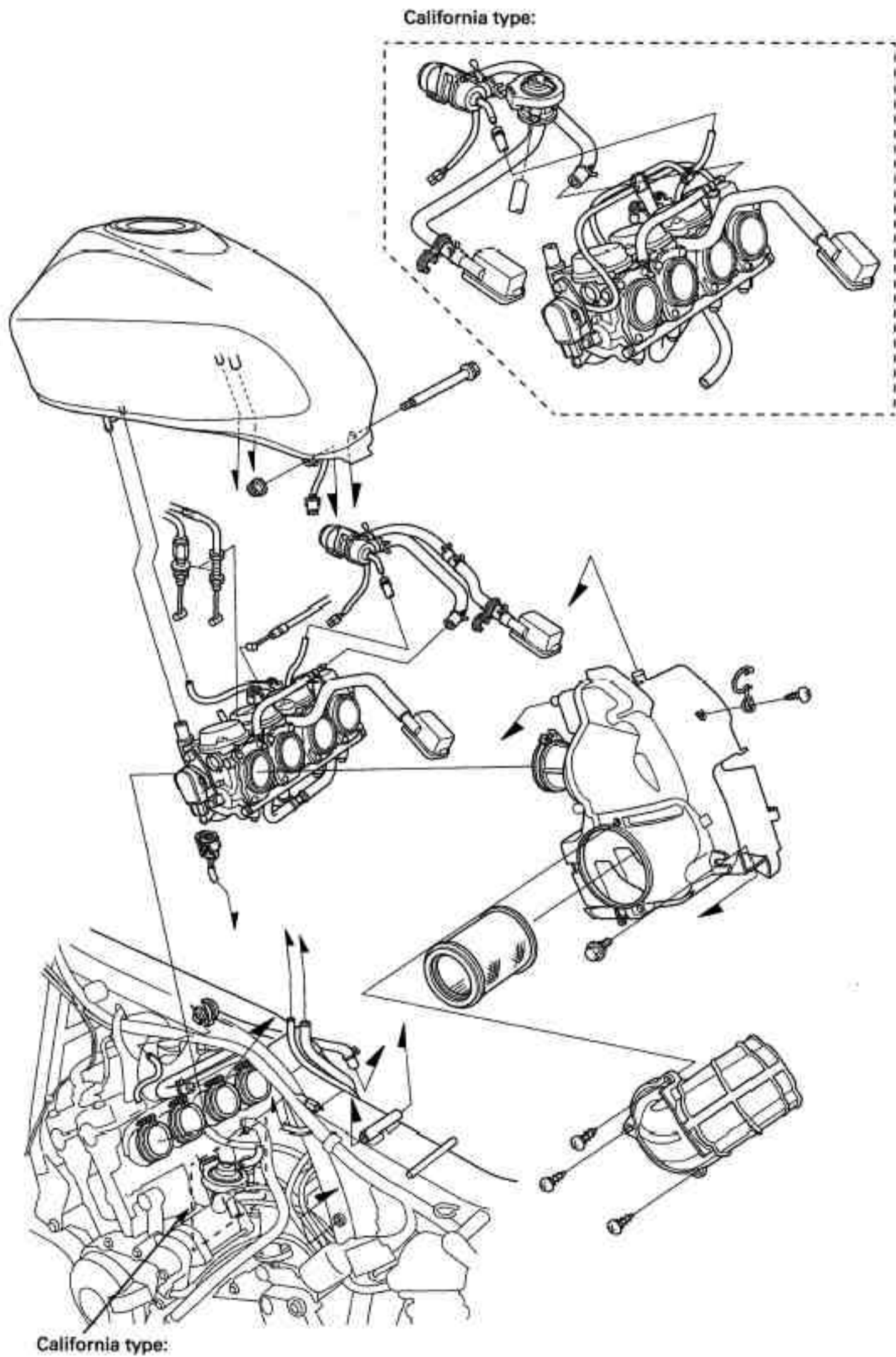

FUEL SYSTEM

SERVICE INFORMATION

GENERAL

- Bending or twisting the control cables will impair smooth operation and could cause the cables to stick or bind, resulting in loss of vehicle control.
- Work in a well ventilated area. Smoking or allowing flames or sparks in the work area or where gasoline is stored can cause a fire or explosion.
- Seal the cylinder head intake ports with tape or a clean cloth to keep dirt and debris from entering the intake ports after the carburetor has been removed.
- Be sure to remove the diaphragms before cleaning air and fuel passages with compressed air. The diaphragms might be damaged.
- Before disassembling carburetor, place the suitable container under the carburetor drain hose. Loosen the bolt and drain the carburetor.
- The vacuum chamber and float chamber can be serviced with the carburetors assembled.
- When disassembling fuel system parts, note the location of the O-rings. Replace them with new ones on reassembly.
- If the vehicle is to be stored for more than one month, drain the float bowls may cause clogged jets resulting in hard starting or poor driveability.
- Refer to procedures for fuel reserve sensor inspection (page 20-23).
- Refer to procedures for fuel tank removal and installation (page 3-6).
- All hoses used in the secondary air supply and evaporative emission control system (California type only) are numbered for identification. When connecting one of these hoses, compare the hose number with the Vacuum Hose Routing Diagram Label on frame or page 1-52, for its proper routing.
- The carburetor hoses routing for after '04 model are different from for '04 model. The removal/installation procedures for '04 model are described in this section basically, refer to the cable and harness routing when removing/installing the carburetor for after '04 model.

SPECIFICATIONS

ITEM		SPECIFICATIONS
Carburetor identification number ('04 model)	Except California type	VP49P
	California type	VP49Q
Carburetor identification number (After '04 model)	Except California type	VP49U
	California type	VP49T
Main jet		No.1/4; #108, No.2/3; #110
Slow jet		#40
Jet needle		B97A
Pilot screw	initial opening	See page 6-35
	high altitude adjustment	See page 6-36
Float level		13.7 mm (0.54 in)
Idle speed		1,400 ± 100 rpm
Throttle grip free play		2 - 6 mm (1/16 - 1/4 in)
Carburetor vacuum difference		Within 30 mm Hg (1.2 in Hg)
Base carburetor for synchronization		No.3 carburetor

TORQUE VALUES

Insulator band screw	See page 6-34
Carburetor drain screw	1.5 N·m (0.15 kgf·m, 1.1 lbf·ft)
Starting enrichment (SE) valve arm screw	1.8 N·m (0.18 kgf·m, 1.3 lbf·ft)
Starting enrichment (SE) valve nut	1.8 N·m (0.18 kgf·m, 1.3 lbf·ft)
Vacuum chamber cover screw	2.1 N·m (0.21 kgf·m, 1.5 lbf·ft)
Air funnel holder screw	2.1 N·m (0.21 kgf·m, 1.5 lbf·ft)
Float chamber screw	3.4 N·m (0.35 kgf·m, 2.5 lbf·ft)
Throttle cable holder screw	3.4 N·m (0.35 kgf·m, 2.5 lbf·ft)
Throttle position (TP) sensor bracket screw	3.4 N·m (0.35 kgf·m, 2.5 lbf·ft)
Carburetor connecting nut, 5 mm	5.1 N·m (0.52 kgf·m, 3.8 lbf·ft)
Carburetor connecting nut, 6 mm	10 N·m (1.0 kgf·m, 7 lbf·ft)

TOOLS

Carburetor float level gauge
07401-0010000

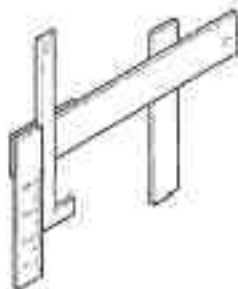

Pilot screw wrench
07KMA-MN90101



or 07MMA-MT3010B (U.S.A. only)
or 07MMA-MT3010A (U.S.A. only)
or 07PMW-MZ2011A

TROUBLESHOOTING

Engine won't start

- Too much fuel getting to the engine
 - Air cleaner clogged
 - Flooded carburetors
- Intake air leak
- Fuel contaminated/deteriorated
- No fuel to the carburetor
 - Fuel strainer clogged
 - Fuel hose clogged
 - Fuel vacuum hose clogged
 - Disconnected fuel valve vacuum hose
 - Float level misadjusted
 - Fuel tank breather hose clogged

Lean fuel mixture

- Fuel jets clogged
- Float valve faulty
- Float level too low
- Fuel line restricted
- Carburetor air vent hose clogged
- Intake air leak
- Throttle valve faulty
- Vacuum piston faulty

Rich fuel mixture

- Starting enrichment valve ON position
- Float valve faulty
- Float level too high
- Air jets clogged
- Air cleaner element contaminated
- Flooded carburetor

Engine stalls, hard to start, rough idling

- Fuel line restricted
- Ignition malfunction
- Fuel mixture too lean/rich
- Fuel contaminated/deteriorated
- Intake air leak
- Idle speed misadjusted
- Float level misadjusted
- Fuel tank breather hose clogged
- Pilot screw misadjusted
- Slow circuit or starting enrichment circuit clogged
- Emission control system malfunction

Afterburn during engine braking is used

- Lean mixture in slow circuit
- Air cut-off valve malfunction
- Emission control system is malfunction
 - Secondary air supply system faulty
 - Loose, disconnected or deteriorated hose of the emission control system

Backfiring or misfiring during acceleration

- Ignition system malfunction
- Fuel mixture too lean

Poor performance (driveability) and poor fuel economy

- Fuel system clogged
- Ignition system malfunction
- Emission control system is malfunction
 - Secondary air supply system faulty
 - Loose, disconnected or deteriorated hose of the emission control system

AIR CLEANER HOUSING

REMOVAL

Remove the following:

- Fuel tank (page 3-6)
- Air cleaner element (page 4-6)
- Battery (page 17-6)

Disconnect the TP (Throttle position) sensor 3P connector.

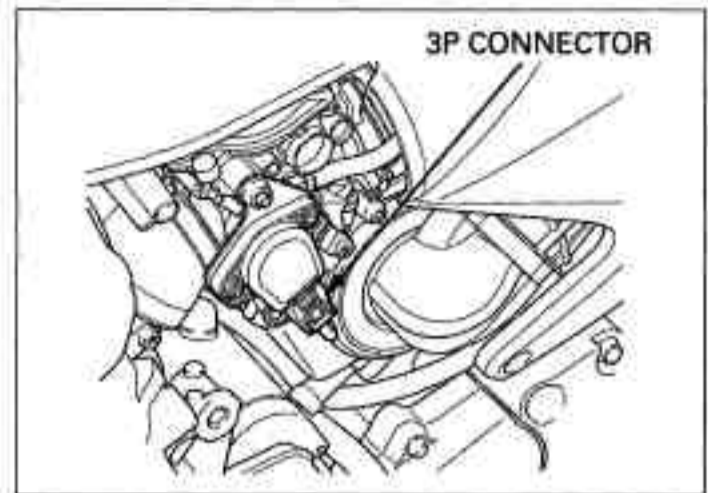

Remove the sub-air cleaner housing clamp screw.

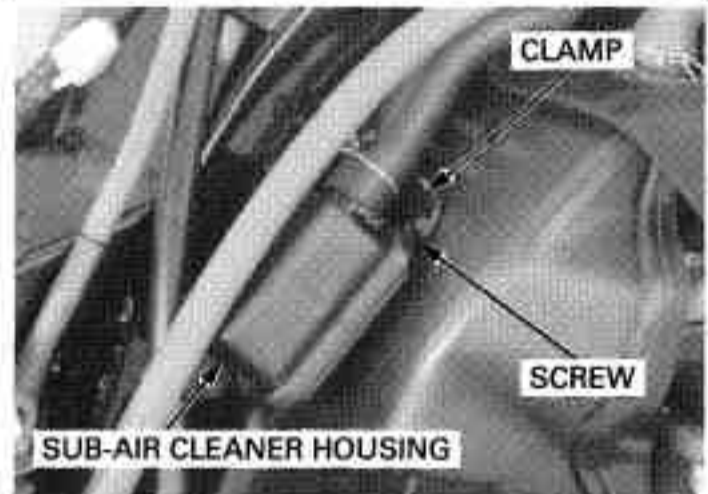

Disconnect the crankcase breather hose from the air cleaner housing.

California type only: Disconnect the No.7 hose from the sub-air cleaner housing and remove the sub-air cleaner housing.



Disconnect the PAIR (Pulse secondary air injection) air suction hose from the air cleaner housing.

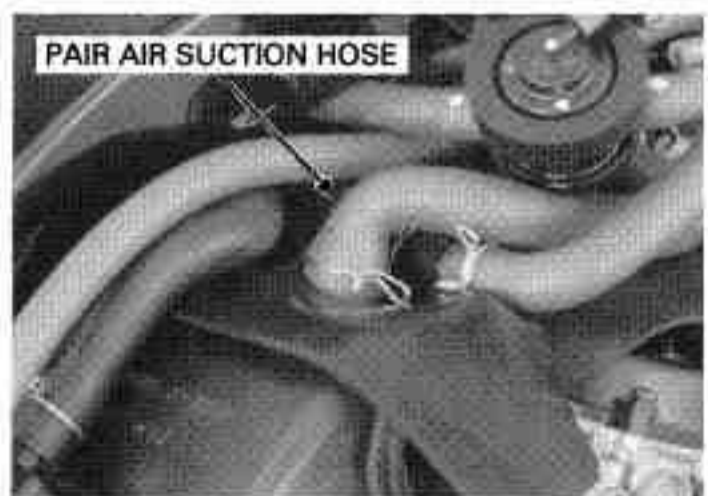

FUEL SYSTEM

Loosen the carburetor connecting boot band screws.

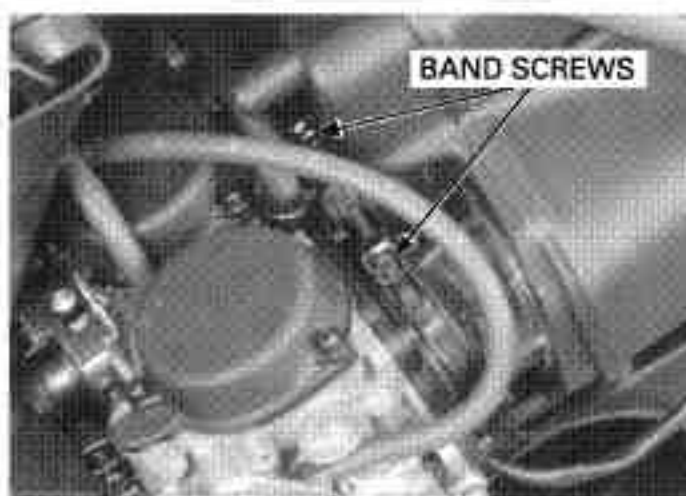

Remove the air cleaner housing mounting bolt.



Remove the air cleaner housing out of the frame to the left side.



INSTALLATION

Install the air cleaner housing into the frame from the left side.



Adjust the carburetor connecting boot band angle as shown.

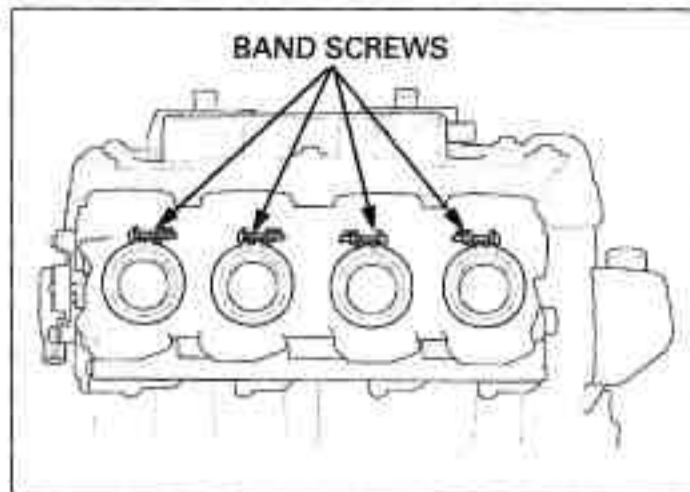

Tighten the connecting boot band screws so that the band ends clearance is 10 ± 1 mm (0.4 ± 0.04 in).

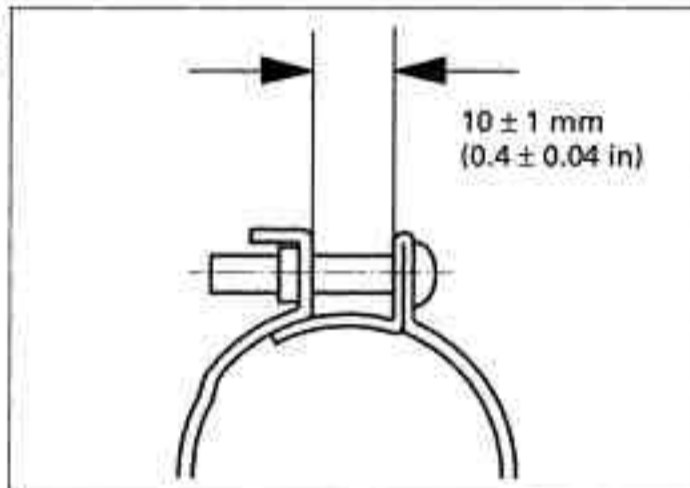

Install and tighten the air cleaner housing mounting bolt.



Connect the PAIR air suction hose to the air cleaner housing.



FUEL SYSTEM

Connect the crankcase breather hose to the air cleaner housing.

California type only:

Connect the No.7 hose to the sub-air cleaner housing and install the sub-air cleaner housing.

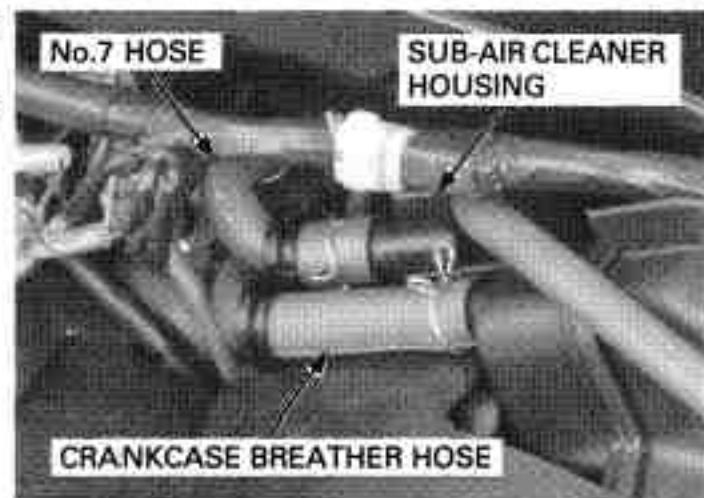

Clean the sub-air cleaner element.

Install the sub-air cleaner housing clamp and tighten the screw securely.

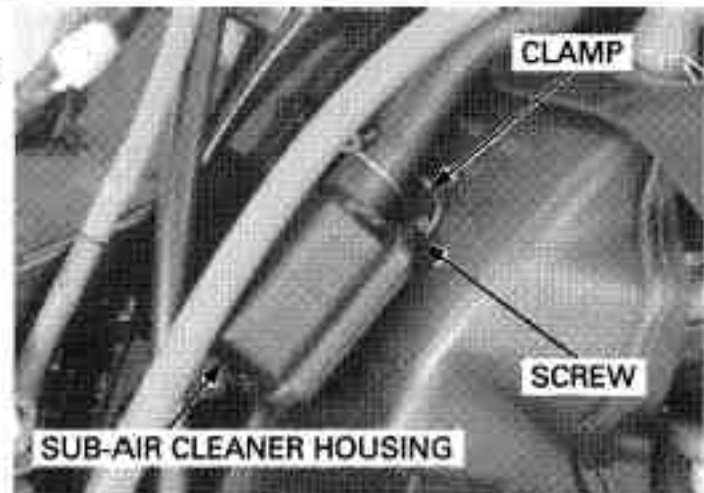

Connect the TP (Throttle position) sensor 3P connector.

Install the following:

- Battery (page 17-6)
- Air cleaner element (page 4-6)
- Fuel tank (page 3-6)

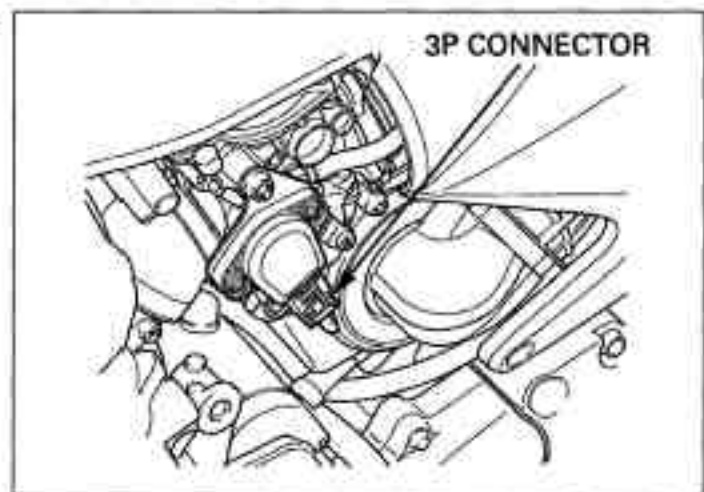

CARBURETOR REMOVAL

Remove the following:

- Air cleaner housing (page 6-7)
- EVAP CAV control valve (page 6-41)
- Fuel cutoff solenoid valve (page 6-42)

Remove the heat guard rubber.

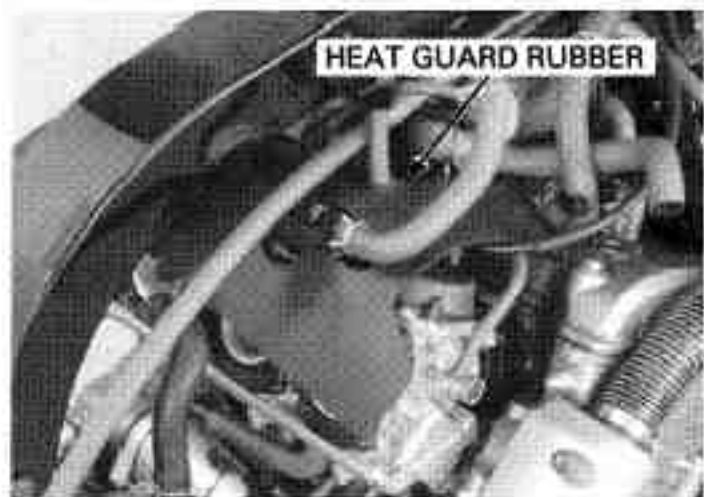

Loosen the carburetor drain screws and catch the fuel with approved gasoline container.



California type only: Disconnect the No.5 and No.11 hoses from the EVAP canister purge valve.

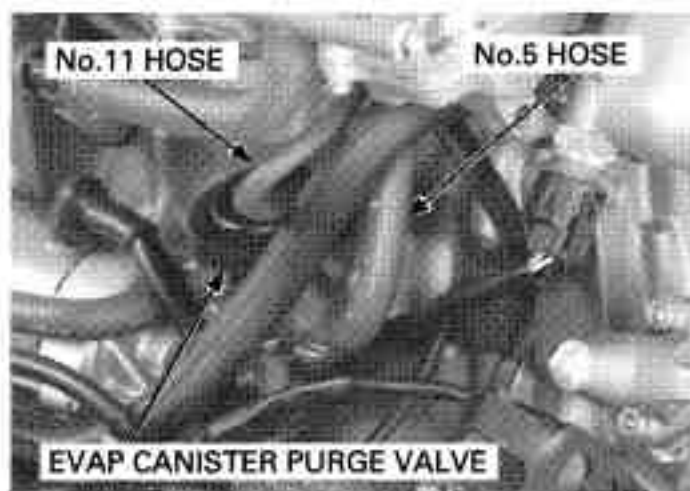

Loosen the carburetor side insulator band screws.

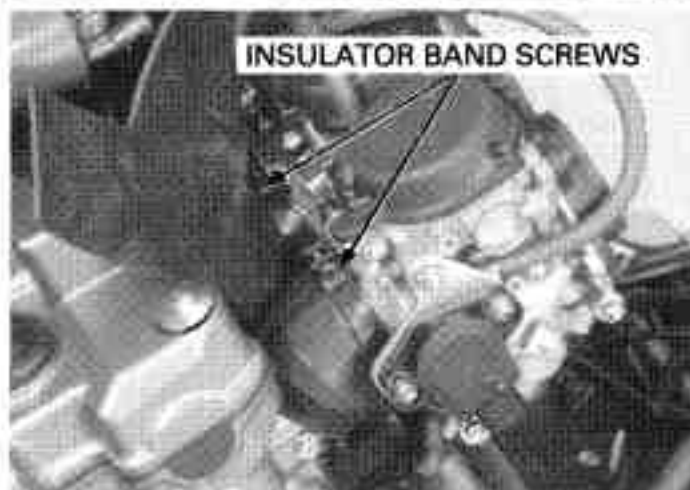

Remove the carburetor assembly from the insulators.
Remove the throttle cables from the cable holder and disconnect the throttle cables from the throttle drum.

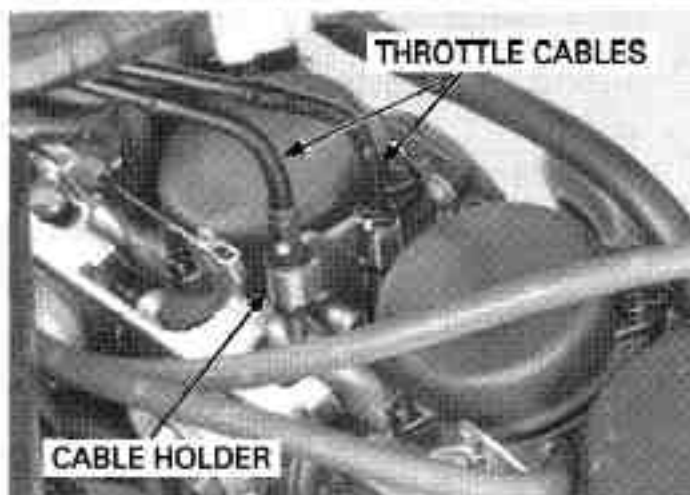

FUEL SYSTEM

Seal the cylinder head intake ports with tape or a clean cloth to keep dirt and debris from entering the intake ports after the carburetor assembly has been removed.

Disconnect the choke cable from the carburetor.

After removing carburetor assembly, do not place it up side down or the air intake might be deformed.

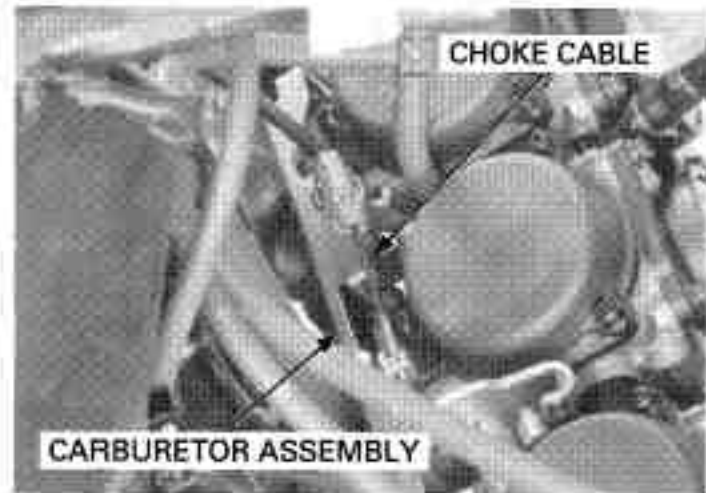

CARBURETOR SEPARATION

- The vacuum chamber and float chamber can be serviced without separating the carburetors.

Disconnect the fuel hose from the fuel joint.
Disconnect the sub-air cleaner hose from the fuel joints.

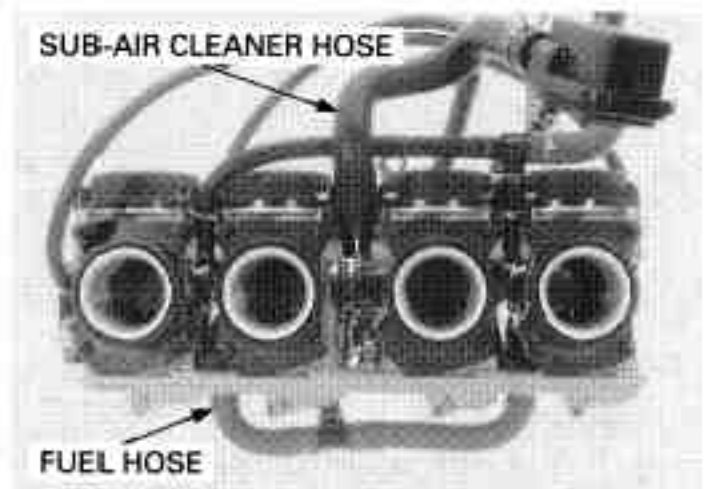

Disconnect the air vent hoses from the air vent joints.

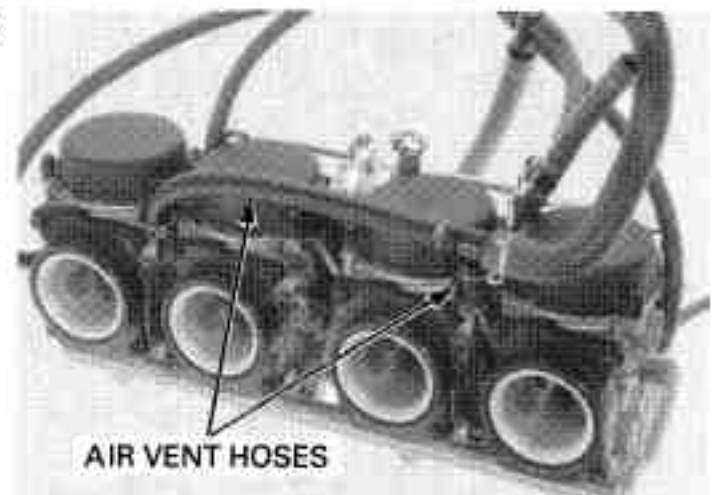

California type only:

Disconnect the No.5 hoses/5-way joint/3-way joint from the carburetor following:

- Disconnect the to No.1 and No.4 carburetors hoses from carburetor hose joints.
- Disconnect the to No.2 carburetor hose from the 5-way joint.
- Disconnect the to No.3 carburetor hose from the 3-way joint.

Disconnect the No.11 hose (to the EVAP canister purge valve) from No.3 carburetor.

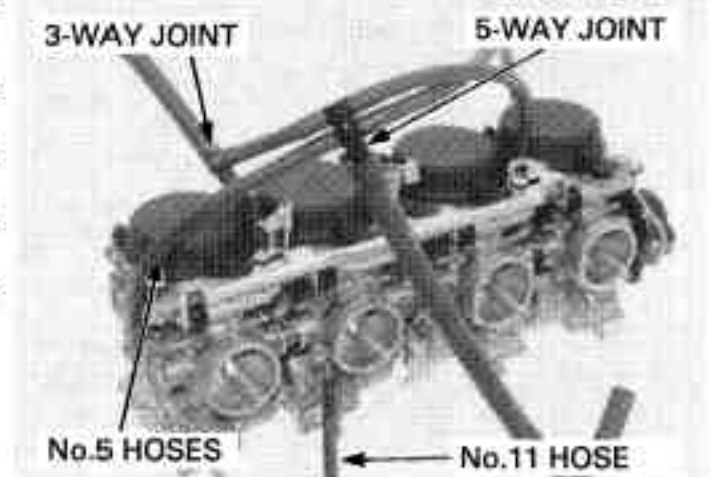

After '04 model only:

Disconnect the PAIR control valve vacuum hose from the No.1 carburetor.

Disconnect the fuel valve vacuum hose from the No.3 carburetor.

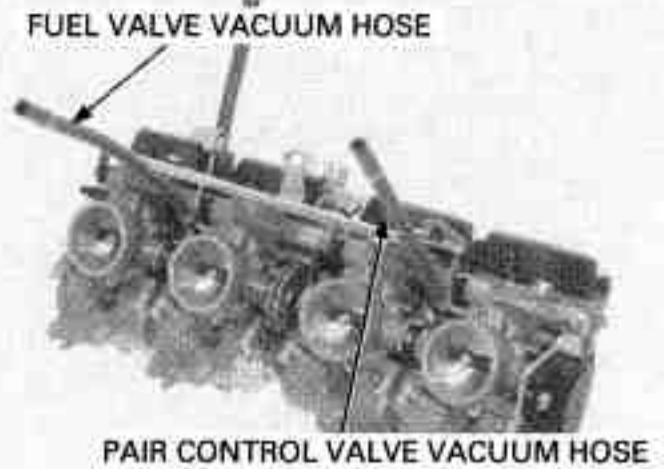

Remove the starting enrichment (SE) valve arm screws, washers and spring. Remove the SE valve arm and plastic collars.

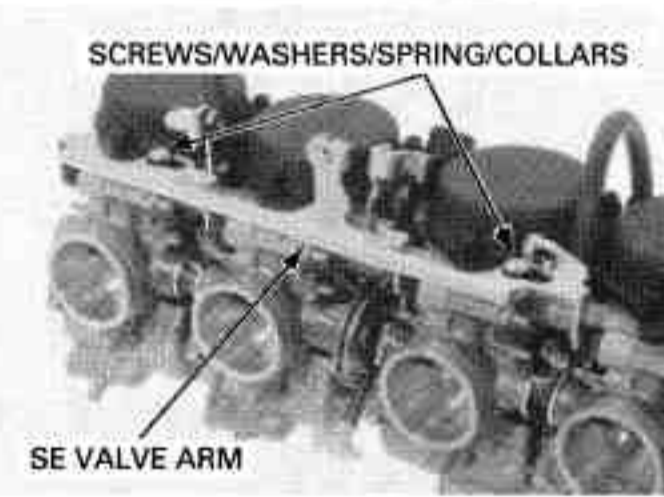

Loosen the nuts gradually and alternately.

Loosen and remove the carburetor connecting 6 mm nut and 5 mm nut.

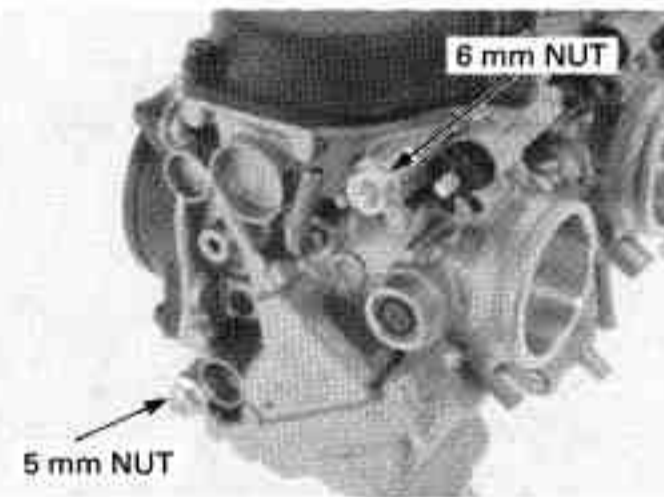

Separate the No.3/4 carburetors from the No.1/2 carburetors.

Remove the following:

- No.2 carburetor synchronization spring
- 3-way air joint pipe/O-rings
- Dowel pin (5 mm bolt side)
- Dowel pin (6 mm bolt side)

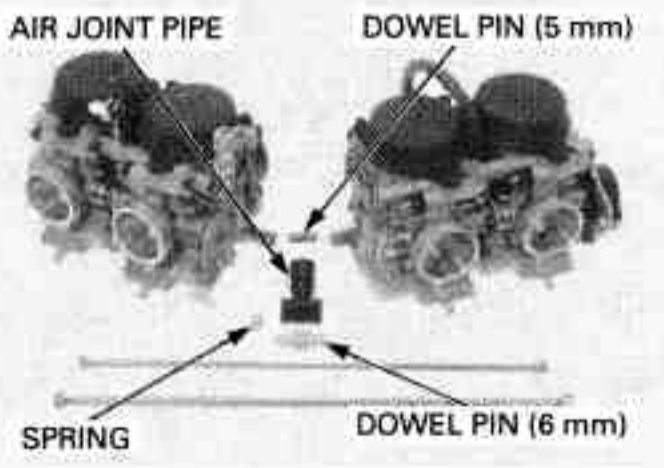

FUEL SYSTEM

Separate the No.1 carburetor from the No.2 carburetor.

Remove the following:

- No.1 carburetor synchronization spring
- Thrust spring
- Air joint rubber pipe
- 3-way air vent joint pipe/O-rings
- 3-way fuel joint pipe/O-rings
- Dowel pin (5 mm bolt side)
- Dowel pin (6 mm bolt side)

Do not disassemble the TP sensor or more.

Remove the screw and TP (Throttle position) sensor from the No.1 carburetor.

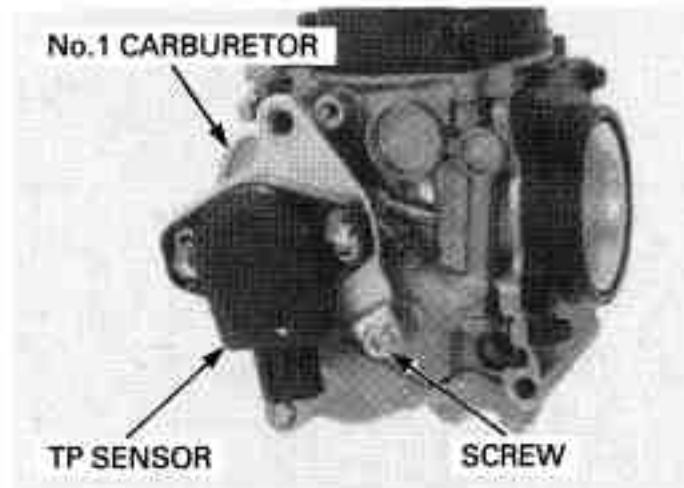
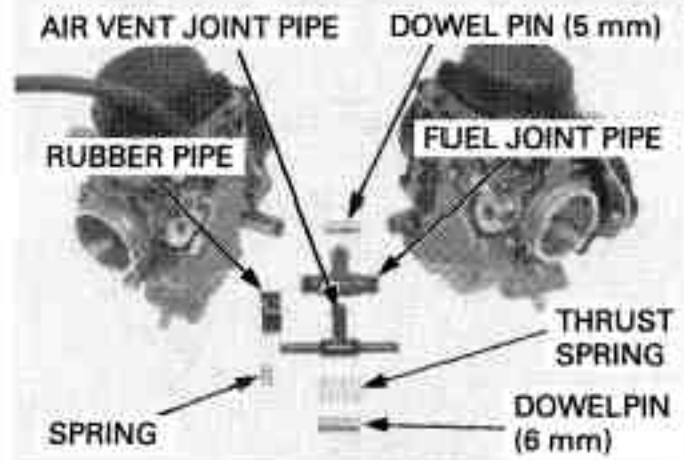

California type only:

Disconnect the No.5 hose from the No.2 carburetor hose joint.

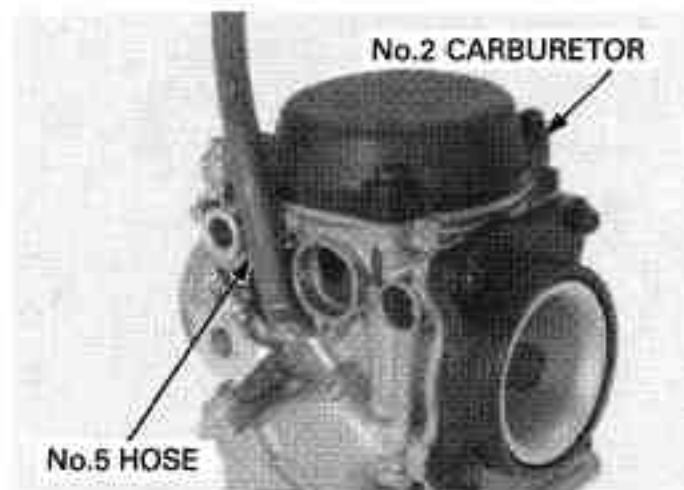

Separate the No.3 carburetor from the No.4 carburetor.

Remove the following:

- Choke cable holder
- No.4 carburetor synchronization spring
- Thrust spring
- Air joint rubber pipe
- 3-way air vent joint pipe/O-rings
- 3-way fuel joint pipe/O-rings
- Dowel pin (5 mm bolt side)
- Dowel pin (6 mm bolt side)

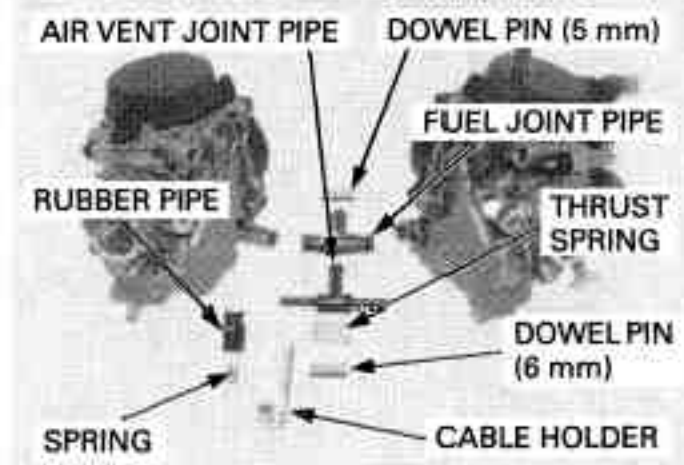

'04 California type
and after '04 model
only:

Disconnect the No.5 hose from the No.3 carburetor
hose joint.

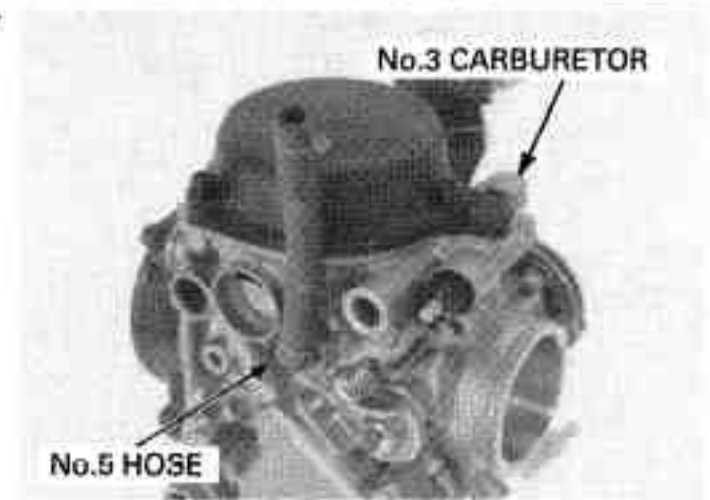

Remove the screws and throttle cable holder from
the No.3 carburetor.

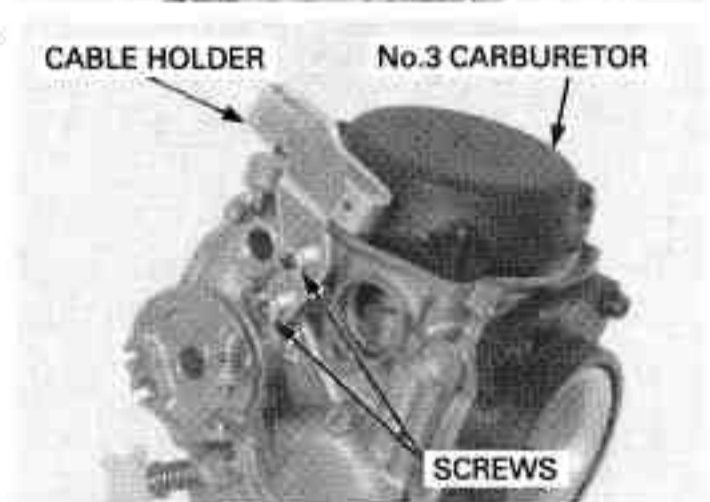

CARBURETOR DISASSEMBLY

AIR FUNNEL

*Note the location of
each carburetor part
so they can be
replaced in their
original location.*

Remove the screws and air funnel holder.

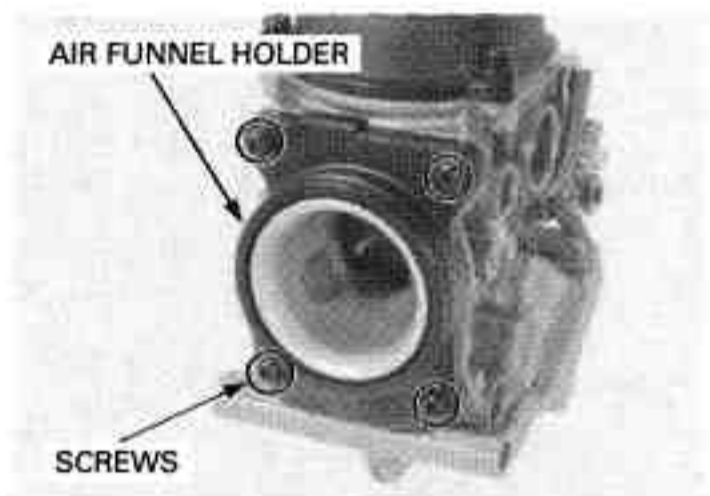

Remove the air funnel from the holder.
Remove the O-ring from the carburetor body.

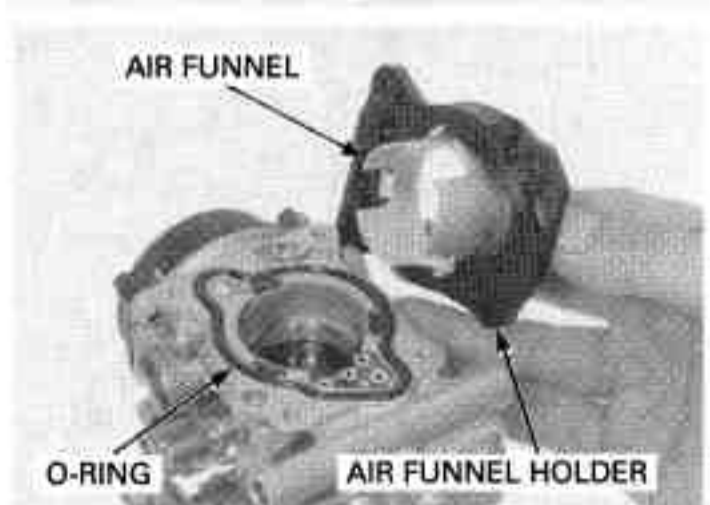

FUEL SYSTEM

SE (STARTING ENRICHMENT) VALVE

Remove the SE valve nut.

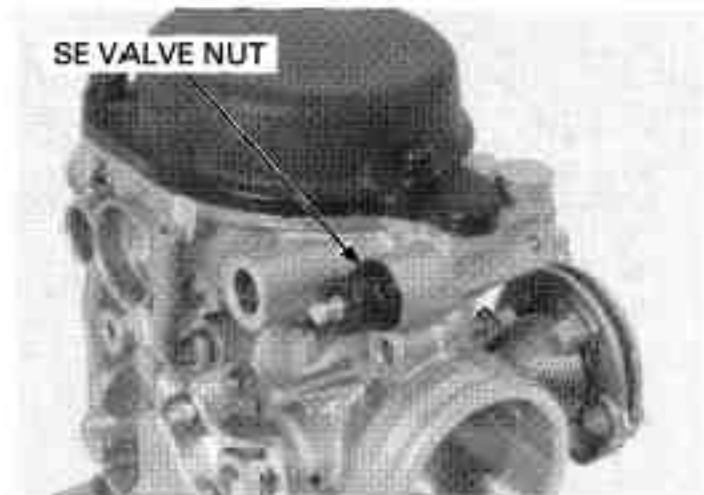

Remove the SE valve and spring.

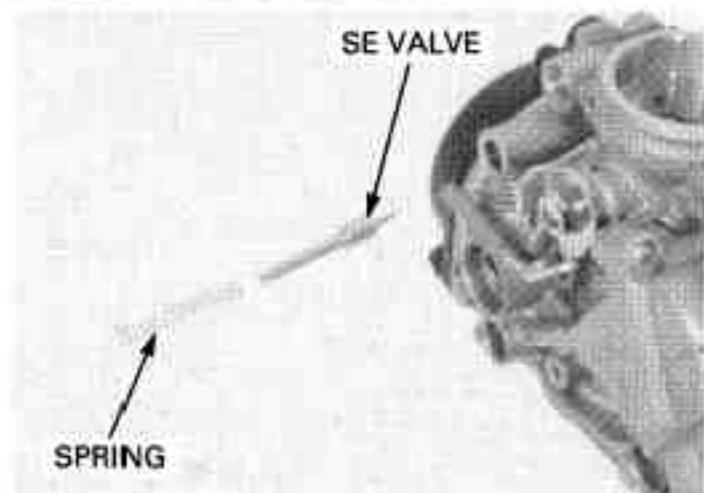

DIAPHRAGM/VACUUM PISTON

Remove the screws and vacuum chamber cover.

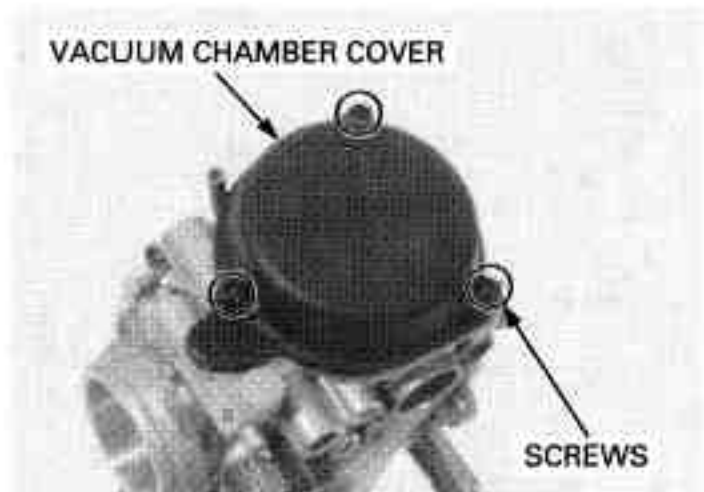

Remove the diaphragm spring and diaphragm/vacuum piston from the carburetor body.

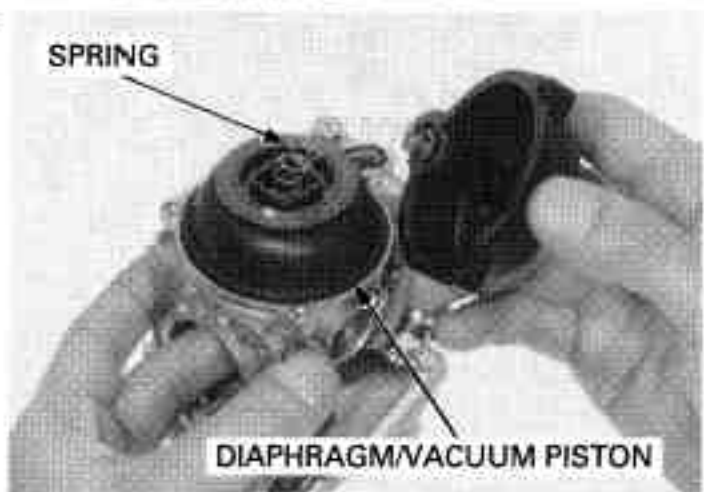

Temporarily install a 4 mm screw (example; vacuum chamber screw) into the jet needle holder. Pull the screw and remove the jet needle holder.

- Be careful not to damage the diaphragm.
- Do not remove the jet needle holder by pushing the jet needle.

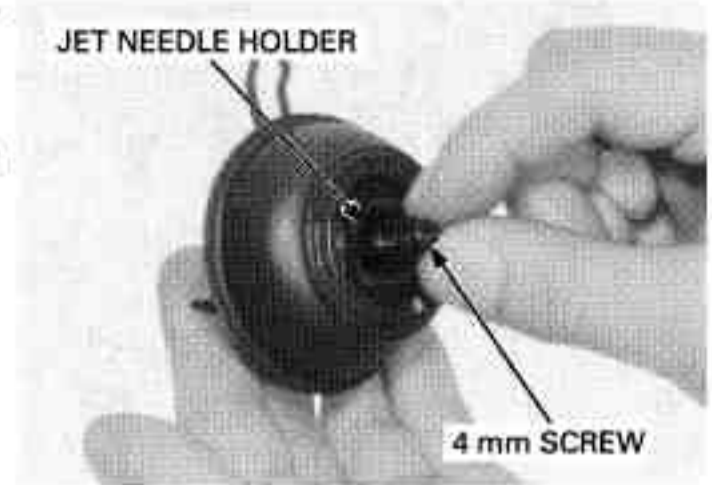

Remove the spring, jet needle and washer from the vacuum piston.

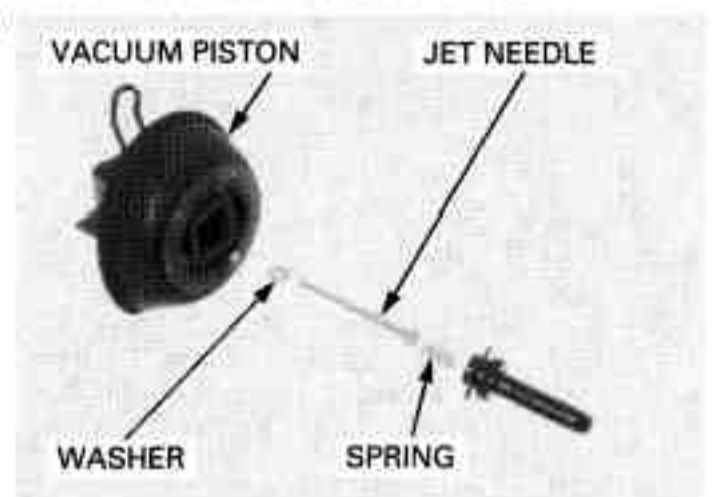

FLOAT AND JETS

Remove the screws and float chamber/O-ring.

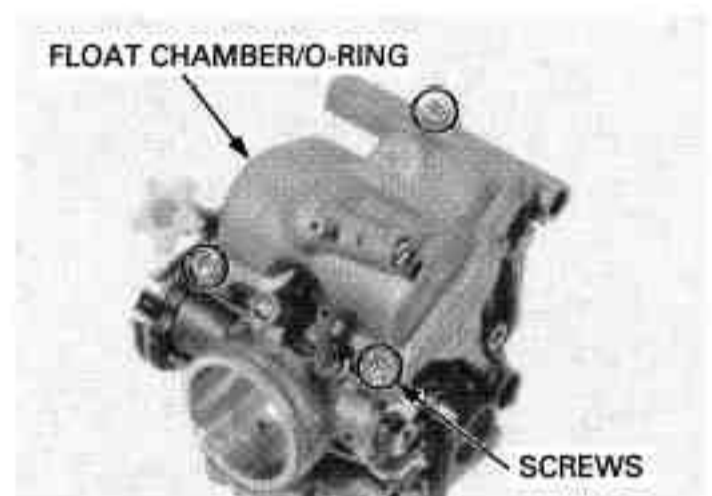

Remove the float pin, float and float valve. Inspect the float for deformation or damage.

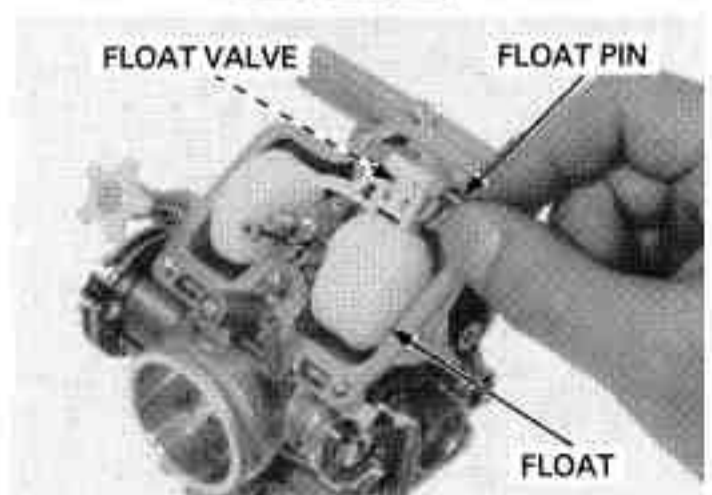

FUEL SYSTEM

Inspect the float valve seat for scores, scratches, clogging and damage.
Check the tip of the float valve where it contacts the valve seat for stepped wear or contamination.
Replace the valve if the tip is worn or contaminated.
Check the operation of the float valve.

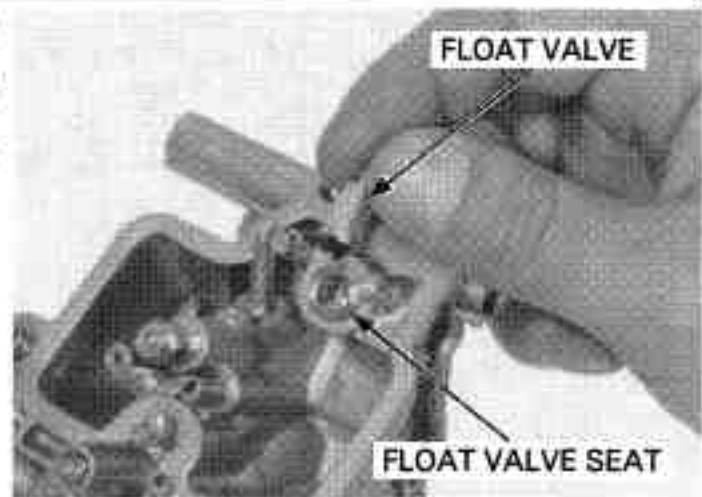

Remove the following:

- Main jet
- Needle jet holder
- Slow jet

Damage to the pilot screw seat will occur if the pilot screw is tightened against the seat.

Turn the pilot screw in and record the number of turns it takes before it seats lightly.

Remove the pilot screw, spring, washer and O-ring.

TOOL:

Pilot screw wrench 07KMA-MN90100 or
07PMA-MZ2011A or
07MMA-MT3010B (U.S.A. only) or
07MMA-MT3010A (U.S.A. only)

MAIN JET/NEEDLE JET HOLDER

SLOW JET

PILOT SCREW/SPRING/WASHER/O-RING

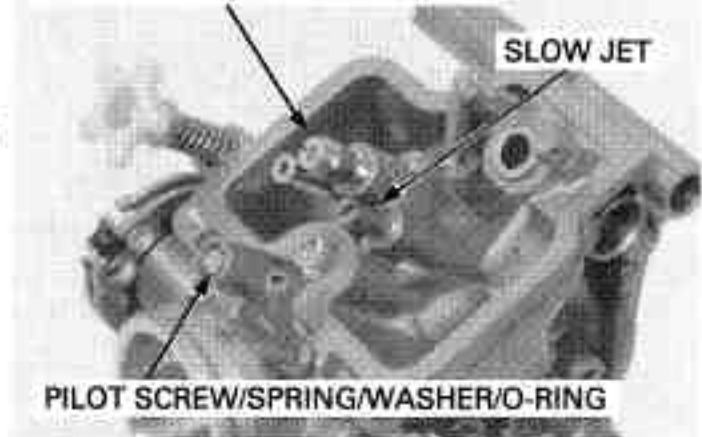

Inspect the each jet for wear or damage and replace if necessary.

PILOT SCREW/SPRING/WASHER/O-RING

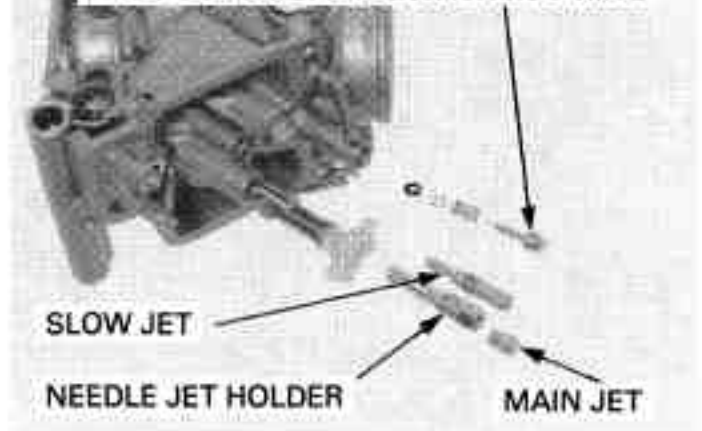

AIR CUT-OFF VALVE (Except '04 California type and after '04 model)

Disconnect the air cut-off valve hose.
Remove the air cut-off valve screw.

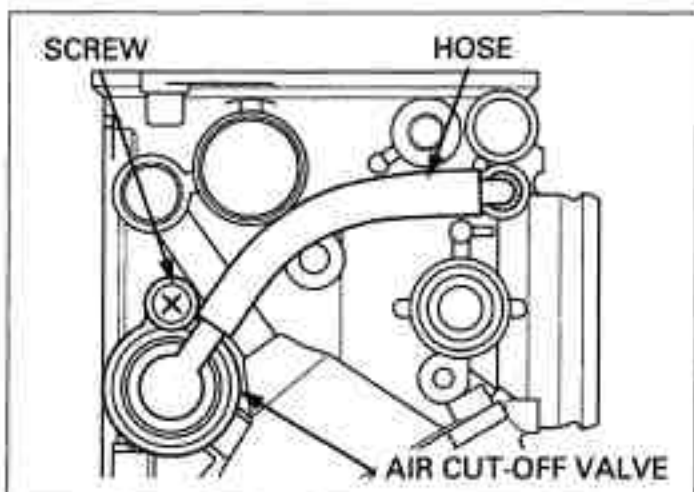

Remove the air cut-off valve, air jet and O-rings.

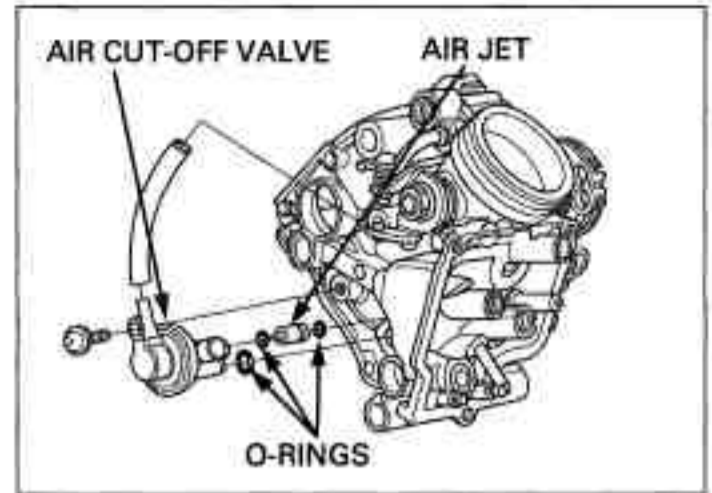

Clean the fuel strainer in the float valve seat using compressed air from the float valve seat side.

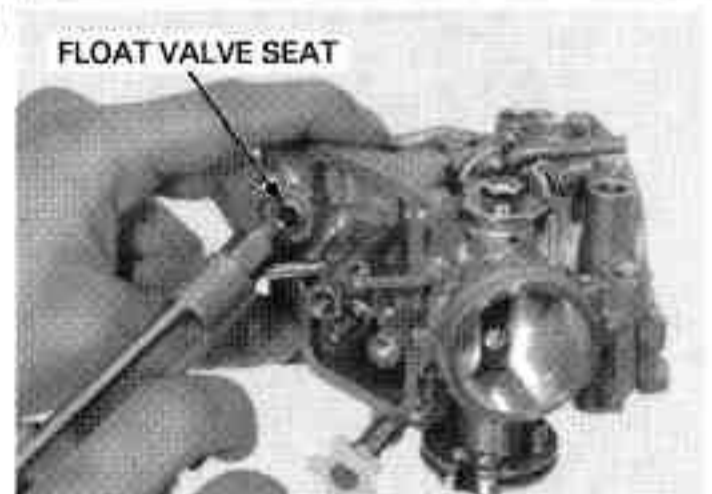

Blow open each air and fuel passages in the carburetor body with compressed air.

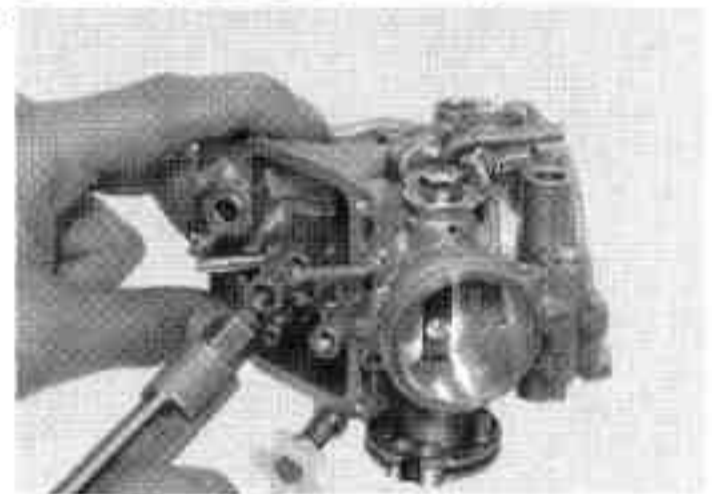

CARBURETOR ASSEMBLY

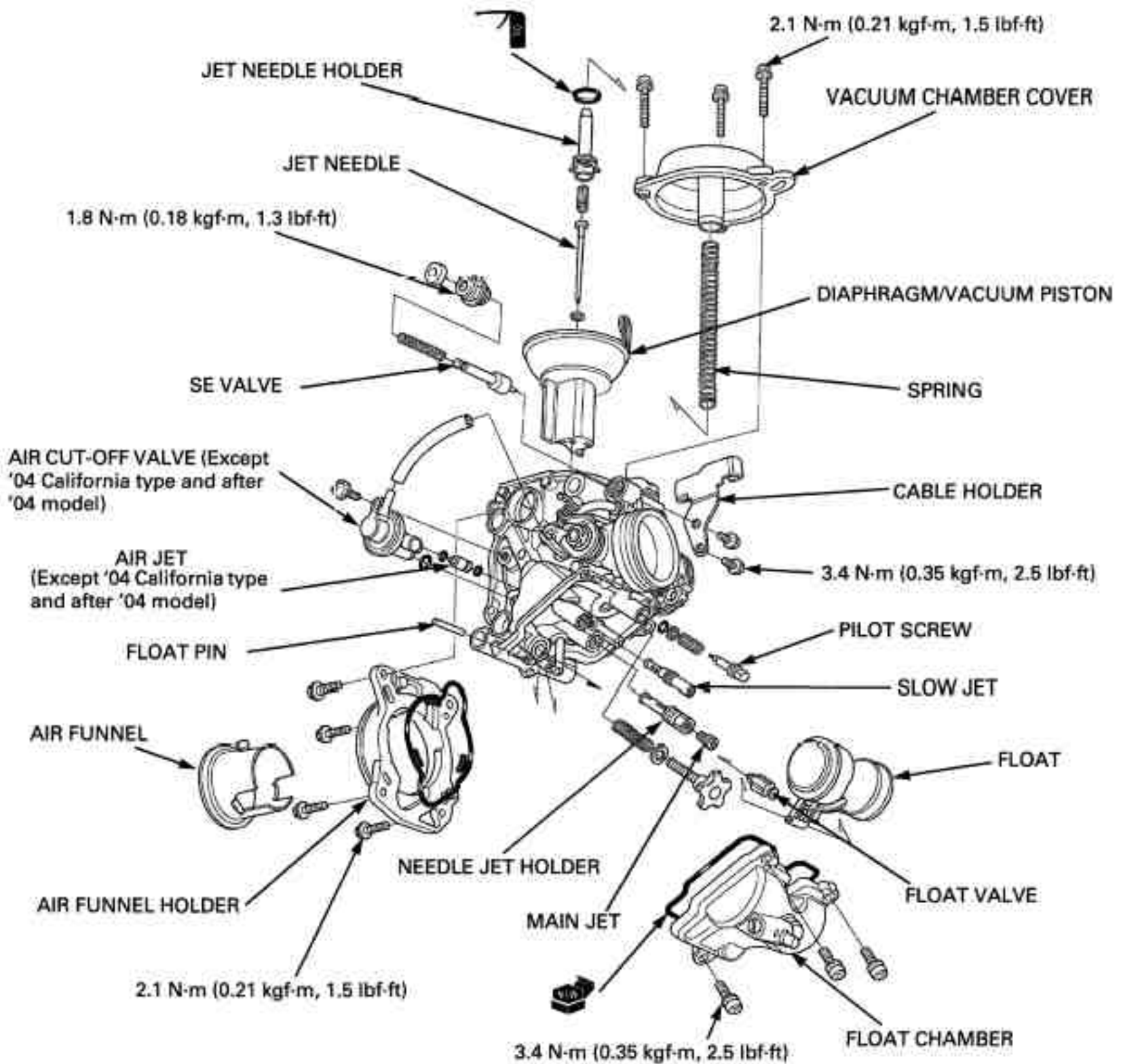

AIR CUT-OFF VALVE (Except '04 California type and after '04 model)

Install the O-ring onto the air jet and air cut-off valve as shown.

Install the air jet with its small end facing the air cut-off valve.

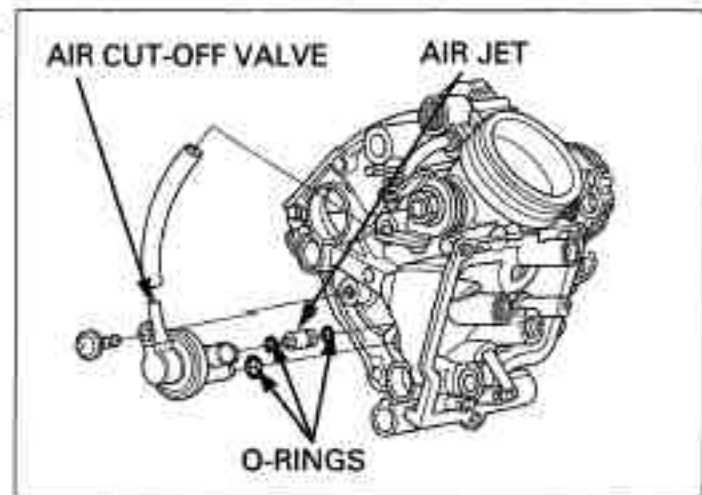

Install the air jet and air cut-off valve onto the carburetor body.

Install and tighten the screw securely.
Connect the air cut off valve hose.

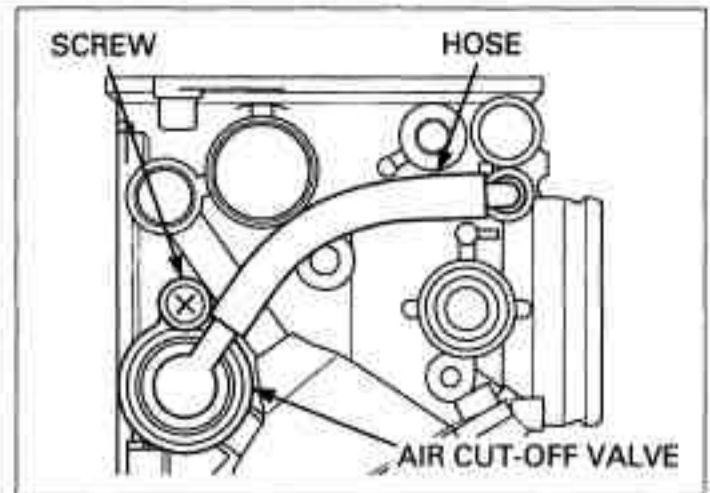

FLOAT AND JETS

Handle all jets with care. They can easily be scored or scratched.

Install the following:

- Slow jet
- Needle jet holder
- Main jet

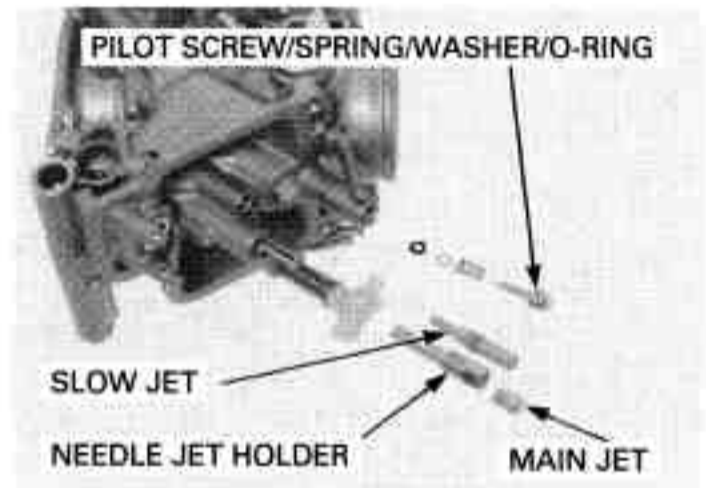

Install the pilot screw and return it to its original position as noted during removal.

TOOL:

- Pilot screw wrench** 07KMA-MN90100 or
 07PMA-MZ2011A or
 07MMA-MT3010B (U.S.A. only) or
 07MMA-MT3010A (U.S.A. only)

Perform the pilot screw adjustment procedure (page 6-35) if a new pilot screw is installed.

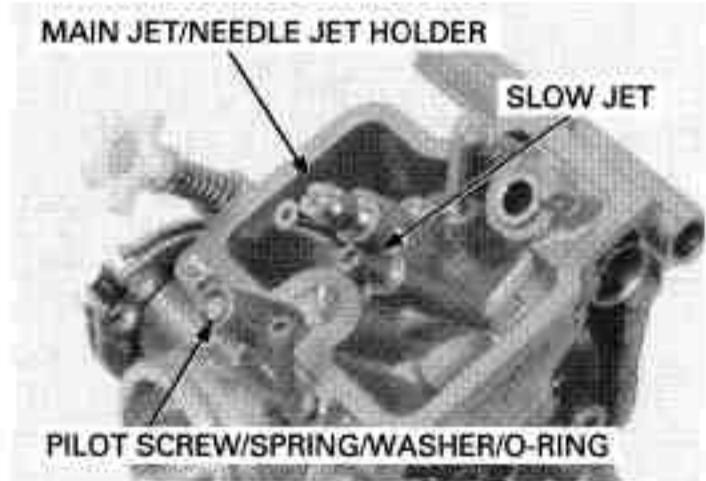

Install the float and float valve in the carburetor body, then install the float pin through the body and float.

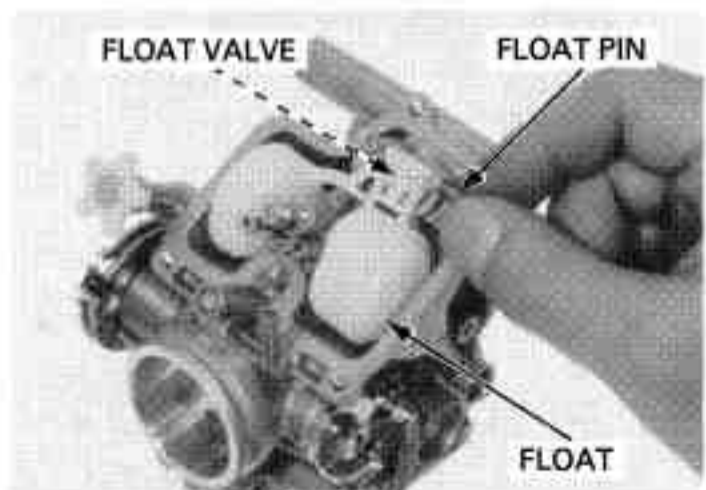

FUEL SYSTEM

FLOAT LEVEL INSPECTION

With the float valve seated and the float arm just touching the valve, measure the float level with the special tool as shown.

FLOAT LEVEL: 13.7 mm (0.54 in)

TOOL:

Carburetor float level gauge 07401-0010000

The float cannot be adjusted.

Replace the float assembly if the float level is out of specification.

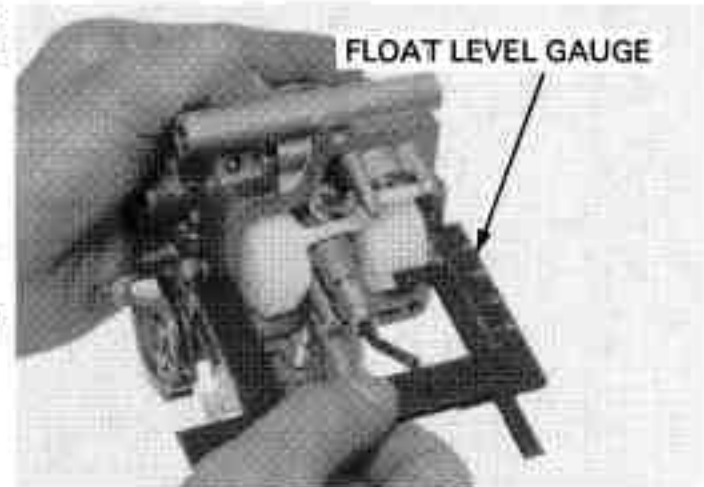

Install a new O-ring in the float chamber.
Install the float chamber.

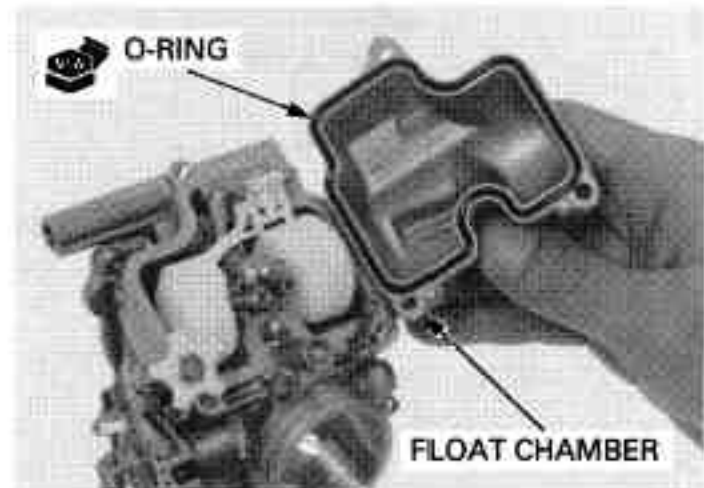

Install and tighten the float chamber screws to the specified torque.

TORQUE: 3.4 N·m (0.35 kgf·m, 2.5 lbf·ft)

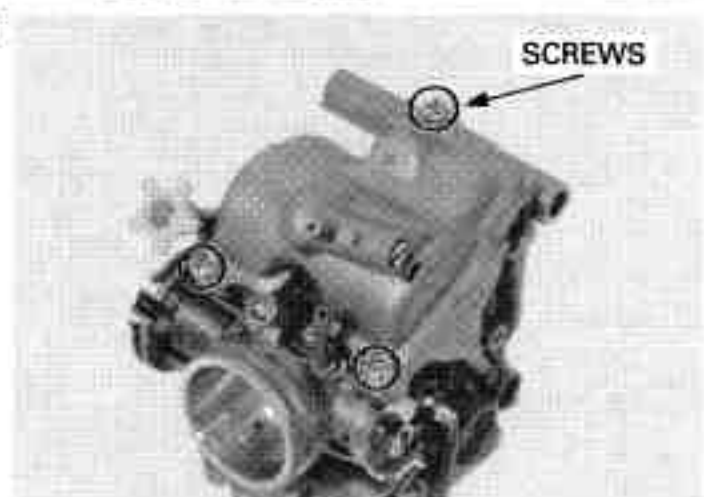

DIAPHRAGM/VACUUM PISTON

Check the condition of the O-ring on the jet needle holder, replace if necessary.
Apply oil to the O-ring.

Install the washer and jet needle holder and spring into the vacuum piston.

Press the jet needle holder into the vacuum piston until you feel a click indicating that the O-ring is seated into the groove in the vacuum piston.

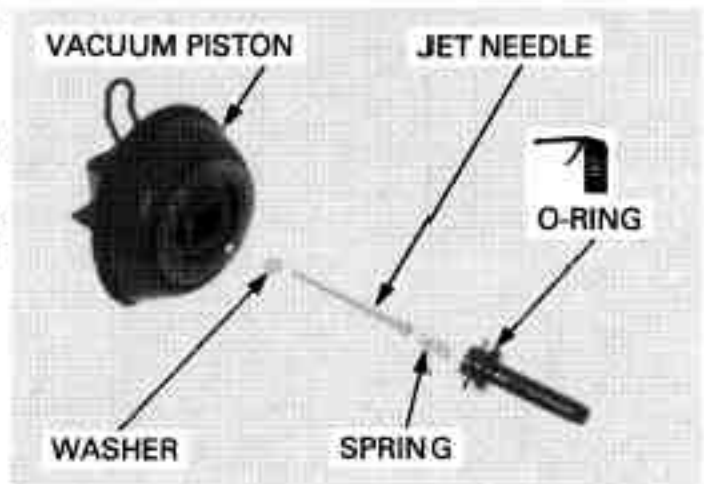

Install the diaphragm/vacuum piston in the carburetor body, aligning the diaphragm tab with the groove of the carburetor body. Hold the vacuum piston almost full open so the diaphragm is not pinched by the chamber cover.

Do not pinch the diaphragm under the chamber cover.

Install the chamber cover with the spring, being careful not to damage the spring.

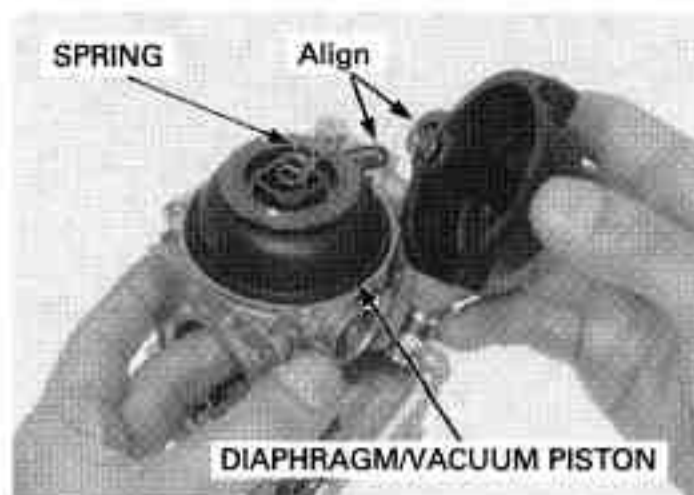

Install and tighten the vacuum chamber cover screws to the specified torque.

TORQUE: 2.1 N·m (0.21 kgf·m, 1.5 lbf·ft)

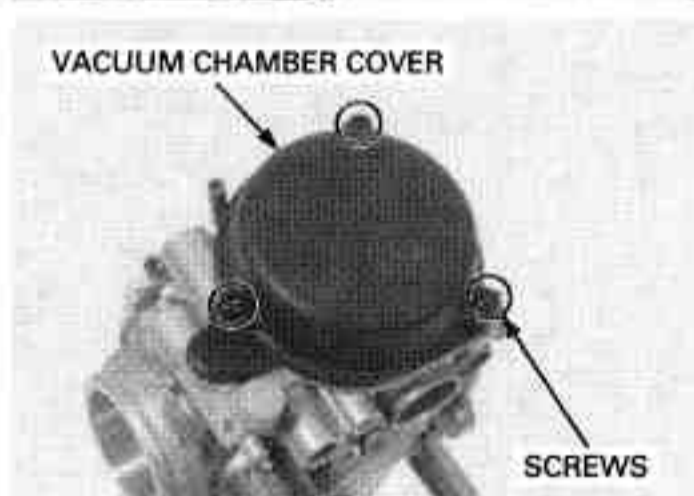

SE (STARTING ENRICHMENT) VALVE

Install the spring and SE (Starting enrichment) valve.

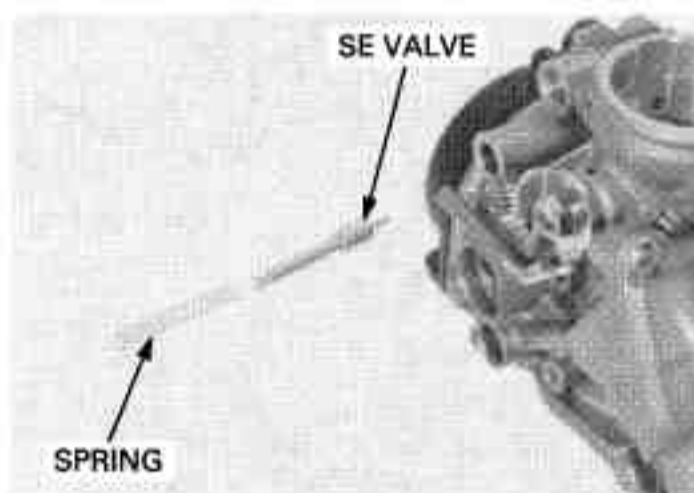

Install and tighten the SE valve nut to the specified torque.

TORQUE: 1.8 N·m (0.18 kgf·m, 1.3 lbf·ft)

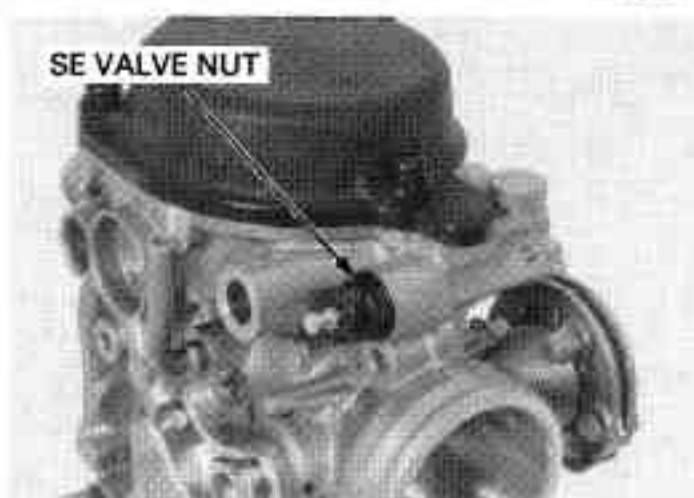

FUEL SYSTEM

AIR FUNNEL

Install the air funnel into the holder as shown.

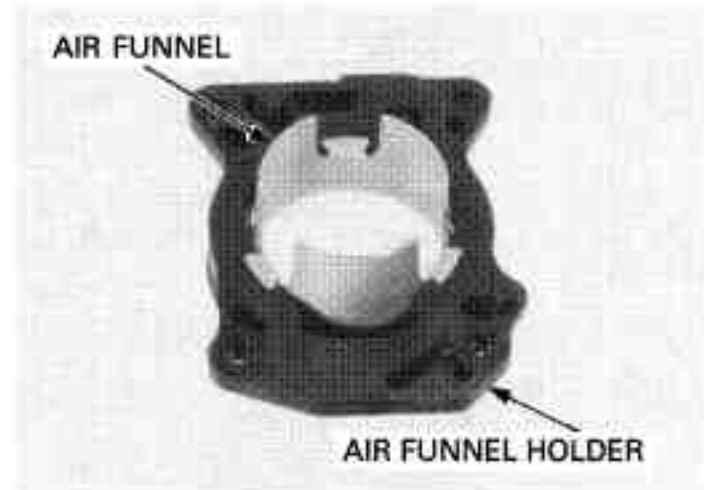

Check that the O-ring is in good condition, replace if necessary.
Install the O-ring into the groove of the carburetor body.

Align the cut-out on the air funnel with the groove in the carburetor body, then install the air funnel/holder.

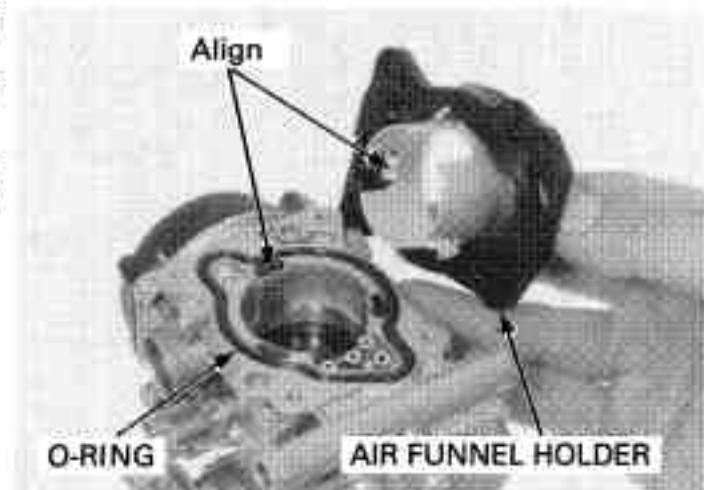

Install and tighten the air funnel holder screws to the specified torque.

TORQUE: 2.1 N-m (0.21 kgf-m, 1.5 lbf-ft)

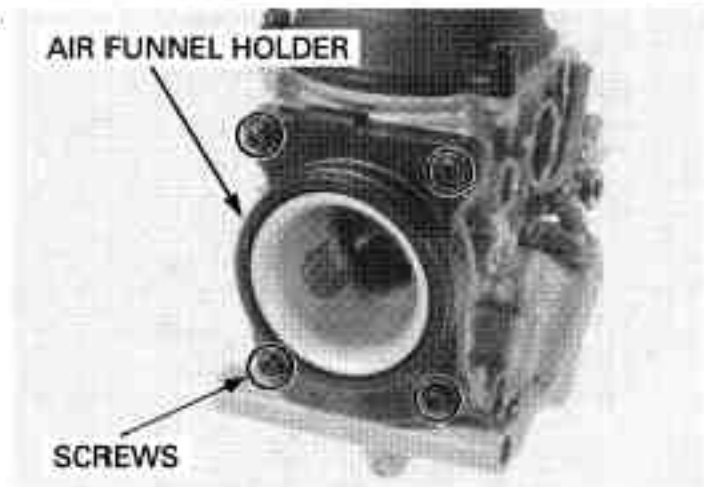

CARBURETOR COMBINATION

Always replace the O-ring with new ones.

EXCEPT CALIFORNIA TYPE:

'04 model shown:

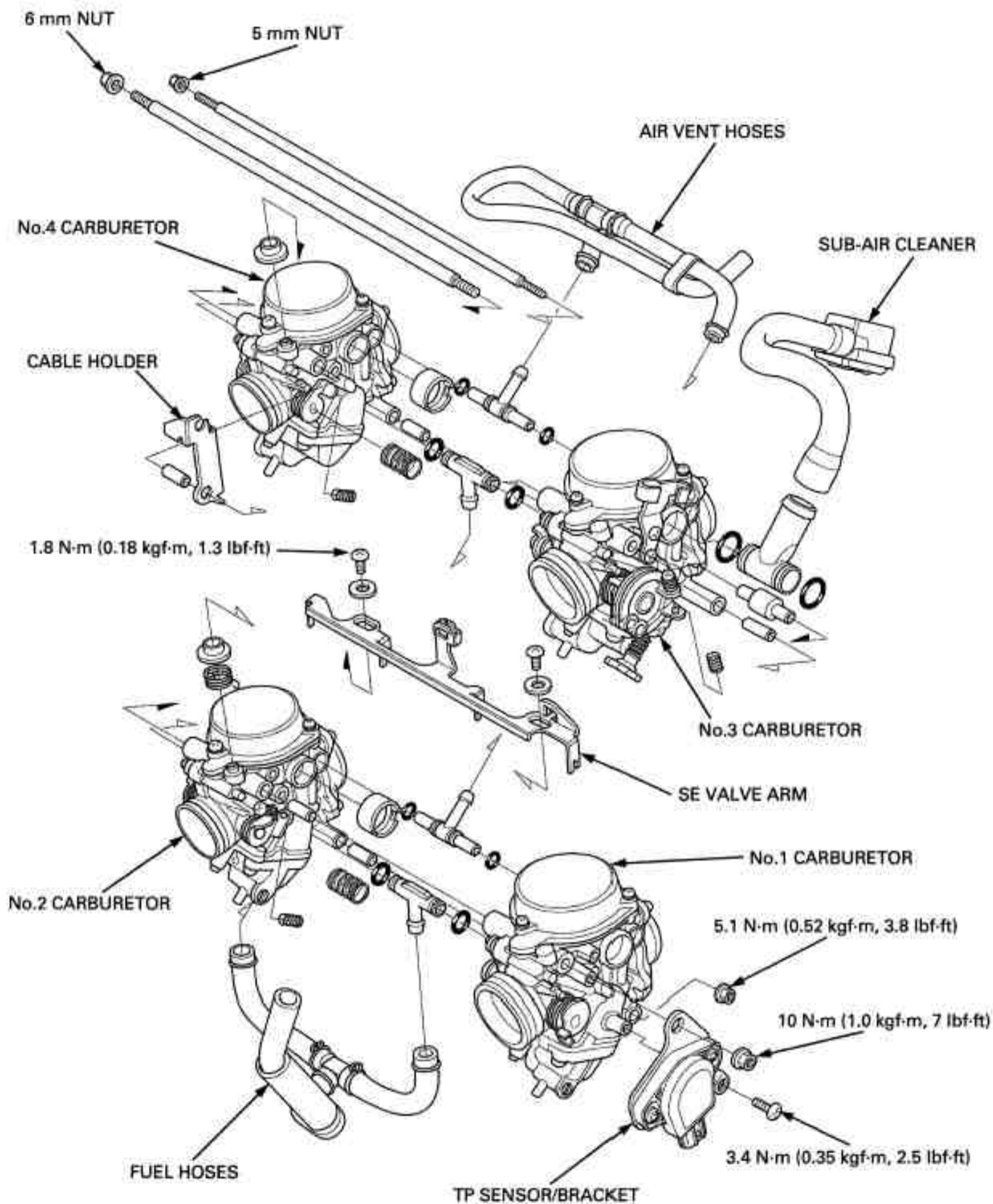

FUEL SYSTEM

CALIFORNIA TYPE:

'04 model shown:

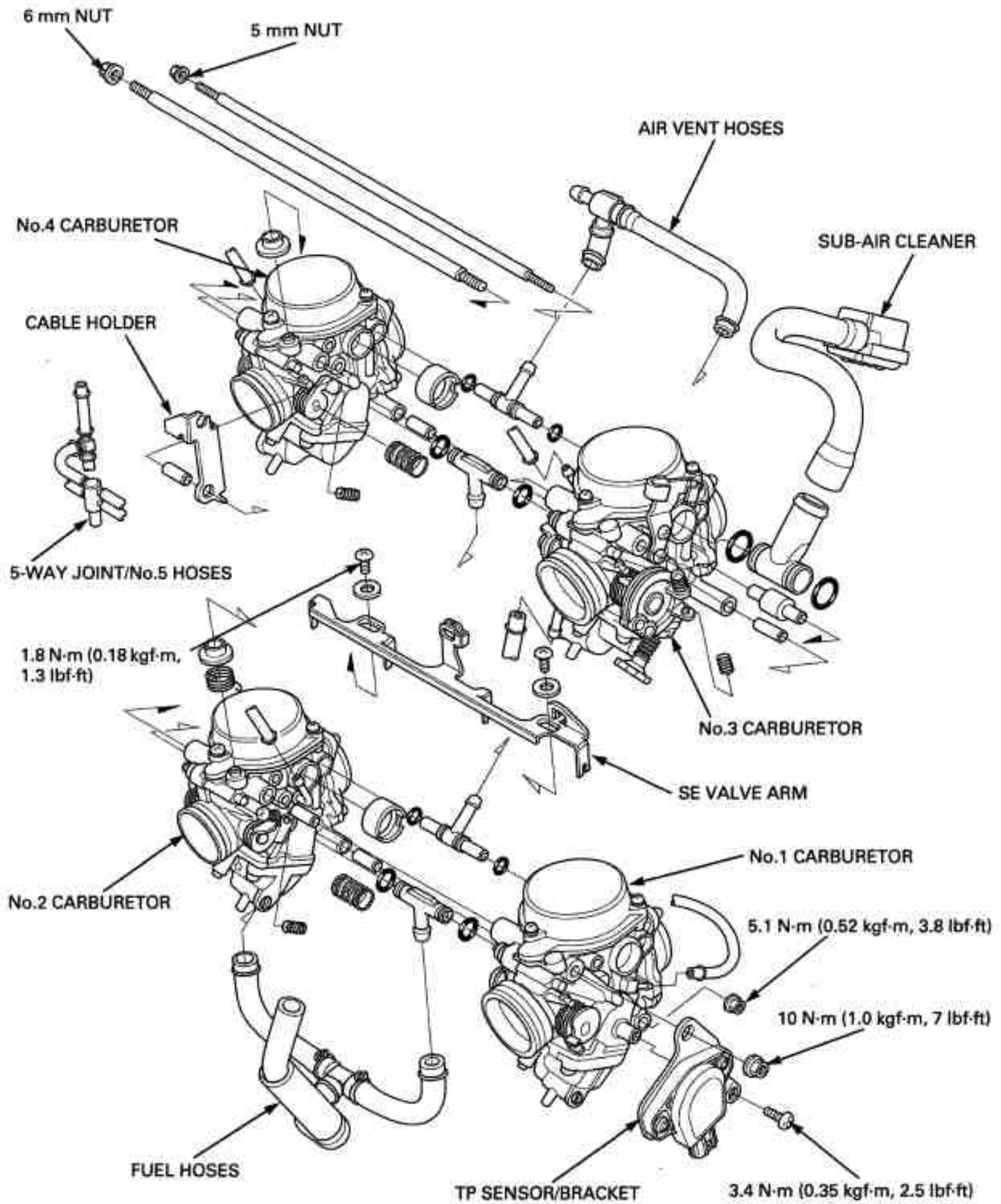

Install the throttle cable holder to the No.3 carburetor and tighten the screws to the specified torque.

TORQUE: 3.4 N-m (0.35 kgf-m, 2.5 lbf-ft)

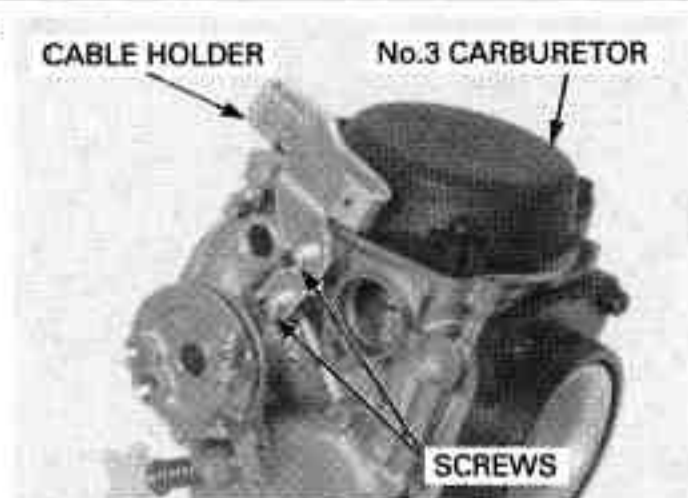

'04 California type and after '04 model only:

Connect the No.5 hose to the No.3 carburetor hose joint.

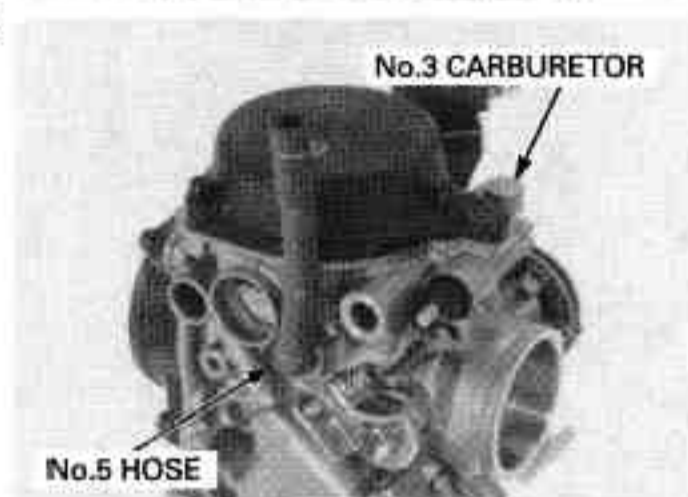

Install the following:

- Dowel pin (5 mm bolt side)
- Dowel pin (6 mm bolt side)
- 3-way fuel joint pipe/new O-rings
- 3-way air vent joint pipe/new O-rings
- Air joint rubber pipe
- Thrust spring
- No.4 carburetor synchronization spring
- Choke cable holder

Assemble the No.3 and No.4 carburetors.

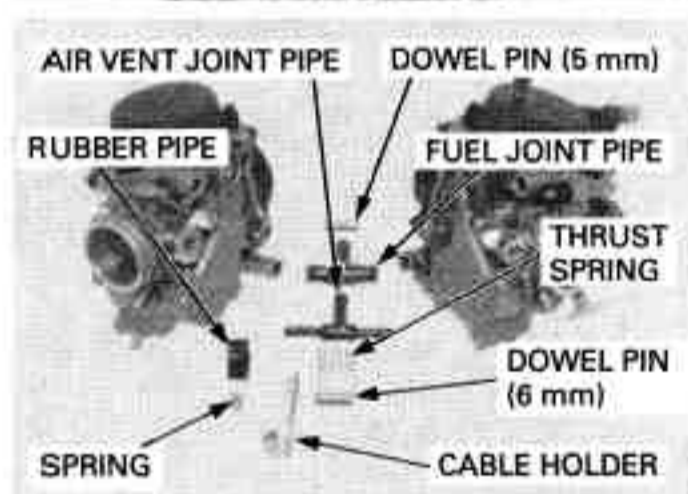

California type only:

Connect the No.5 hose to the No.2 carburetor hose joint.

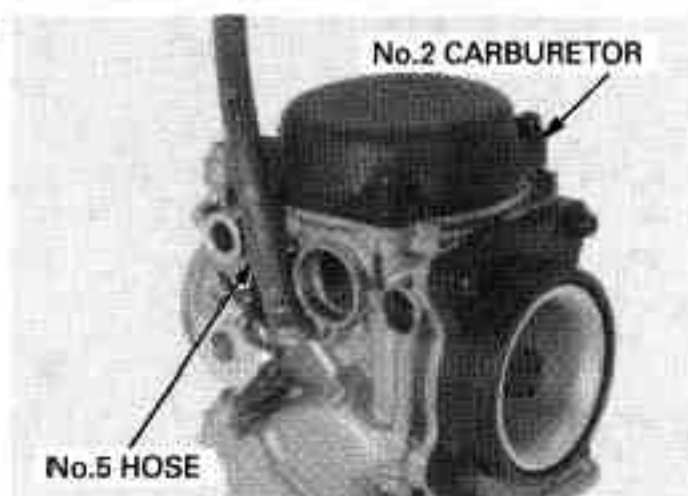

FUEL SYSTEM

Install the TP (Throttle position) sensor/bracket aligning its groove with the lug of the throttle shaft.

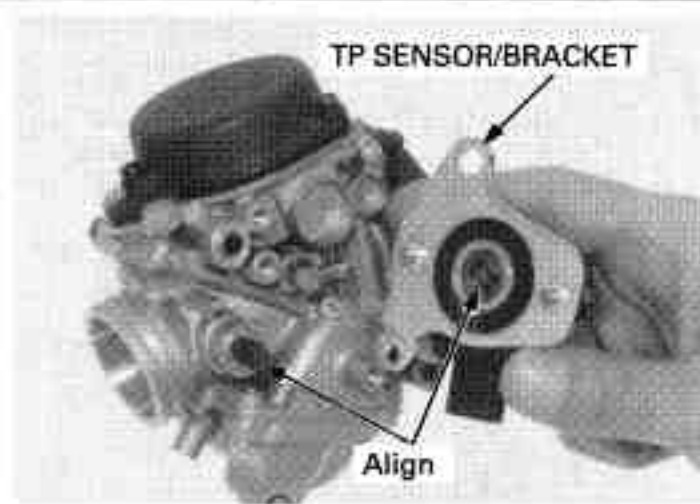

Install and tighten the screw to the specified torque.

TORQUE: 3.4 N·m (0.35 kgf·m, 2.5 lbf·ft)

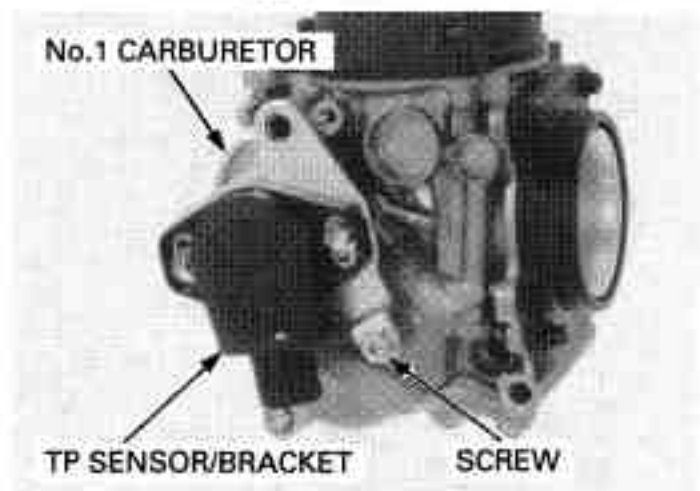

Install the following:

- Dowel pin (5 mm bolt side)
- Dowel pin (6 mm bolt side)
- 3-way fuel joint pipe/new O-rings
- 3-way air vent joint pipe/new O-rings
- Air joint rubber pipe
- Thrust spring
- No.1 carburetor synchronization spring
- Choke cable holder

Assemble the No.1 and No.2 carburetors.

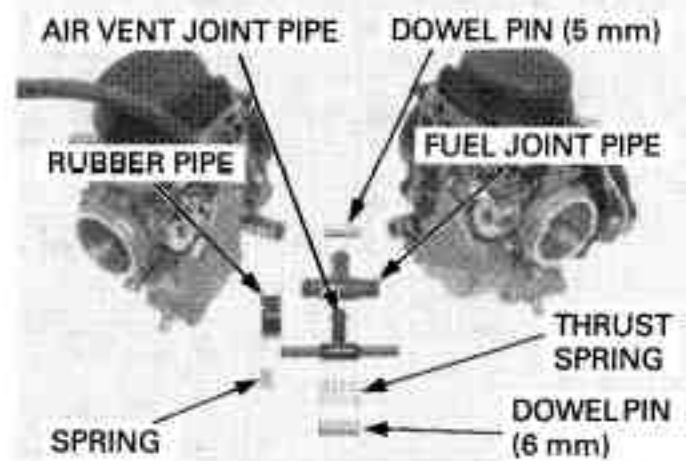

Install the following:

- No.2 carburetor synchronization spring
- 3-way air joint pipe/O-rings
- Dowel pin (5 mm bolt side)
- Dowel pin (6 mm bolt side)

Assemble the No.3/4 carburetors from the No.1/2 carburetors.

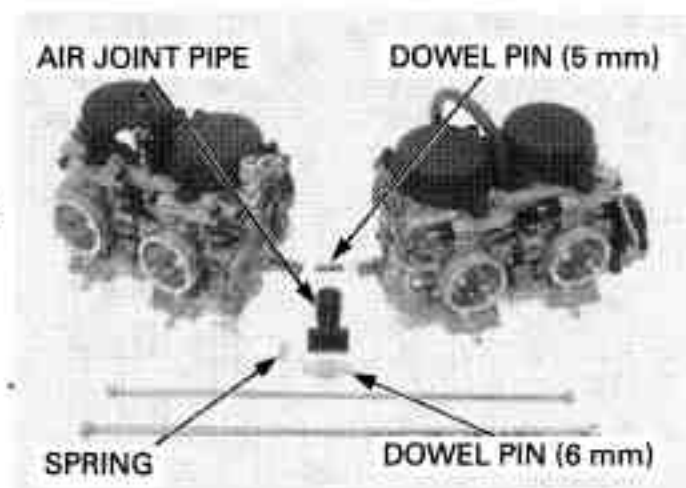

Install the 5 mm and 6 mm carburetor connecting bolts through the carburetors.

Check there is no clearance between each of the carburetor joints.

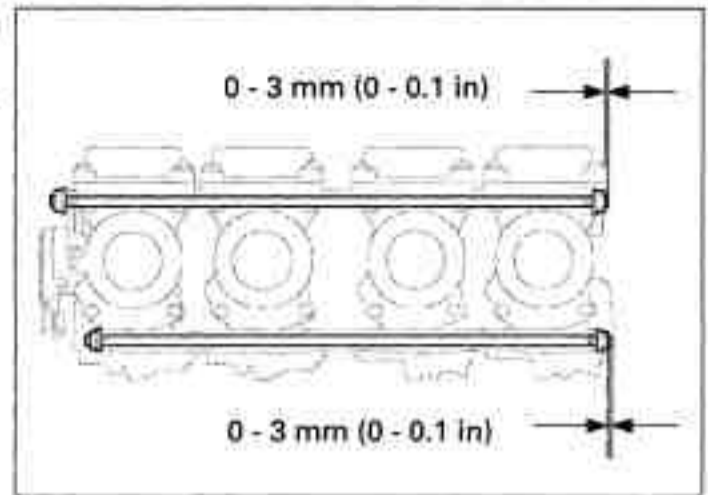

Tighten each connecting nuts gradually and alternately, be sure the bolt thread projections are equal height.

Hold the nut and tighten the nut on other side to the specified torque.

TORQUE:

5 mm nut: 5.1 N·m (0.52 kg·m, 3.8 lbf·ft)

6 mm nut: 10 N·m (1.0 kgf·m, 7 lbf·ft)

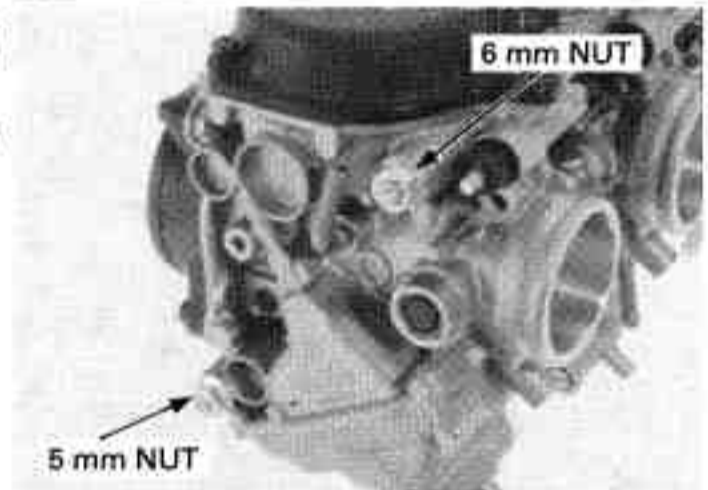

Install the spring to the No.2 carburetor body.

Install the plastic collars onto the No.2 and No.4 carburetor bodies.

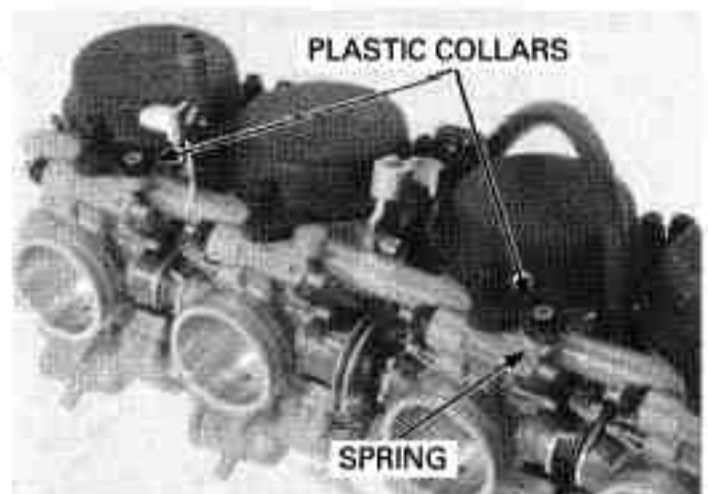

Install the SE valve arm aligning its ends with the SE valve heads.

Align the spring hook to the SE valve arm hook.

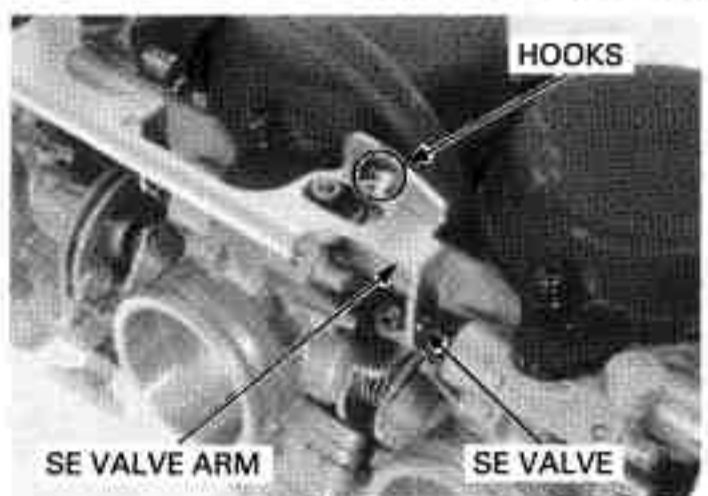

FUEL SYSTEM

Install the plastic washers and tighten the SE valve arm screws to the specified torque.

TORQUE: 1.8 N·m (0.18 kgf·m, 1.3 lbf·ft)

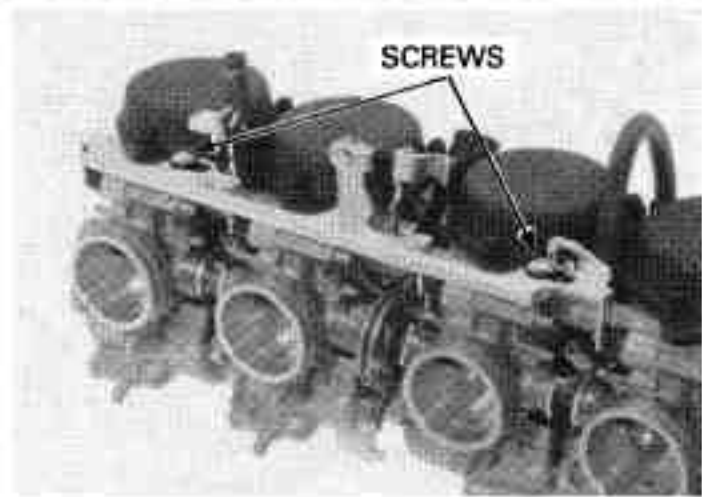

After '04 model only: Connect the PAIR control valve vacuum hose from the No.1 carburetor.

Connect the fuel valve vacuum hose from the No.3 carburetor.

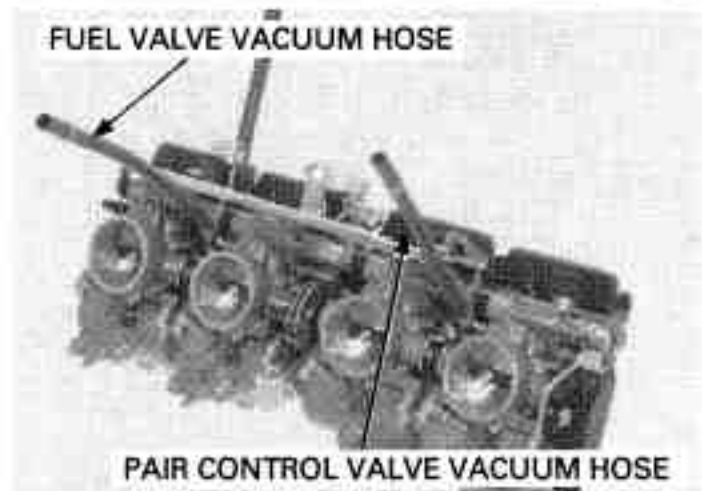

California type only: Connect the No.5 hoses/5-way joint/3-way joint from the carburetor following:

- Disconnect the to No.1 and No.4 carburetors hoses from carburetor hose joints.
- Disconnect the to No.2 carburetor hose from the 5-way joint.
- Disconnect the to No.3 carburetor hose from the 3-way joint.

Connect the No.11 hose (to the EVAP canister purge valve) from No.3 carburetor.

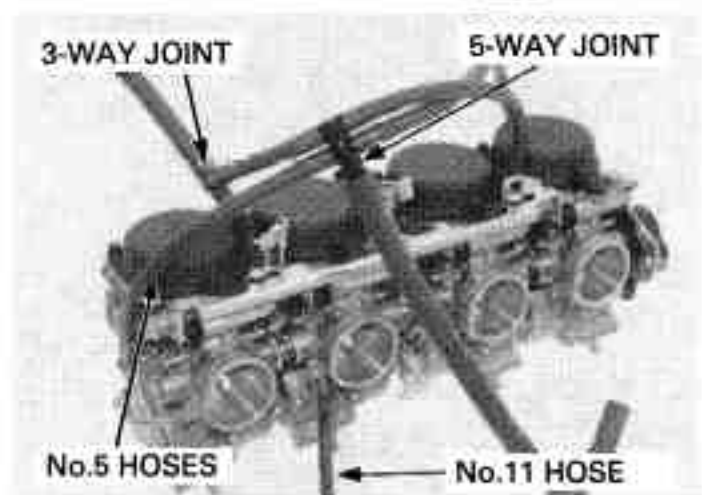

Connect the relevant hoses to the air vent joints.

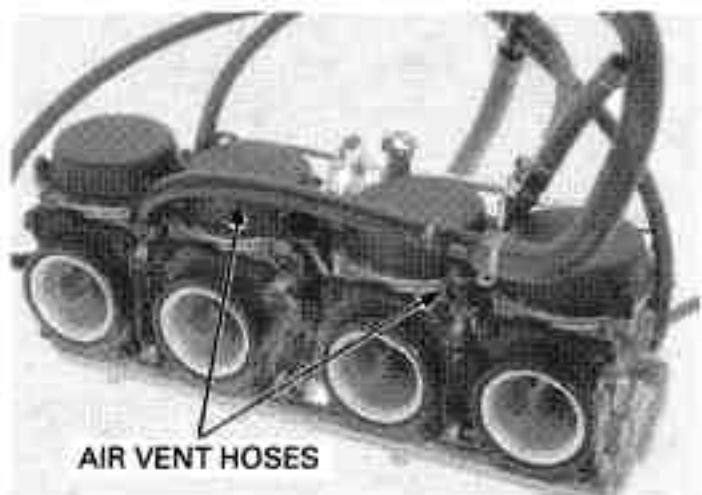

Connect the fuel hose to the fuel joint.
Connect the sub-air cleaner hose to the fuel joints.

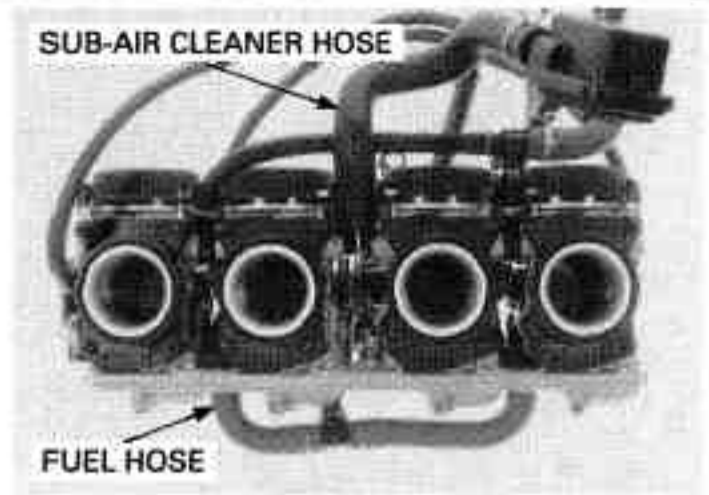

FUEL SYSTEM

CARBURETOR HOSE ROUTING ('04 MODEL, EXCEPT CALIFORNIA TYPE)

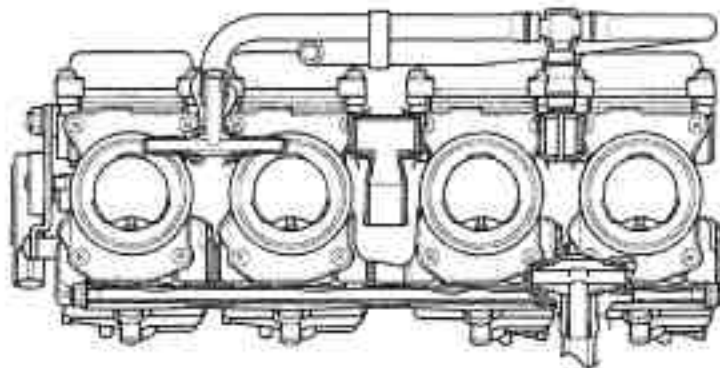
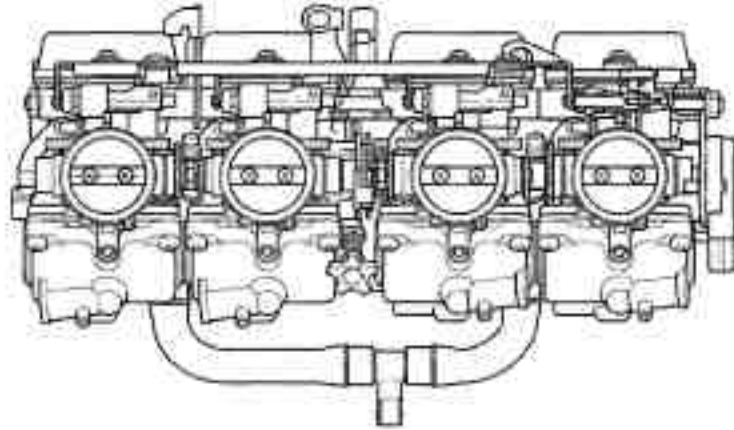

CARBURETOR HOSE ROUTING (AFTER '04 MODEL, EXCEPT CALIFORNIA TYPE)

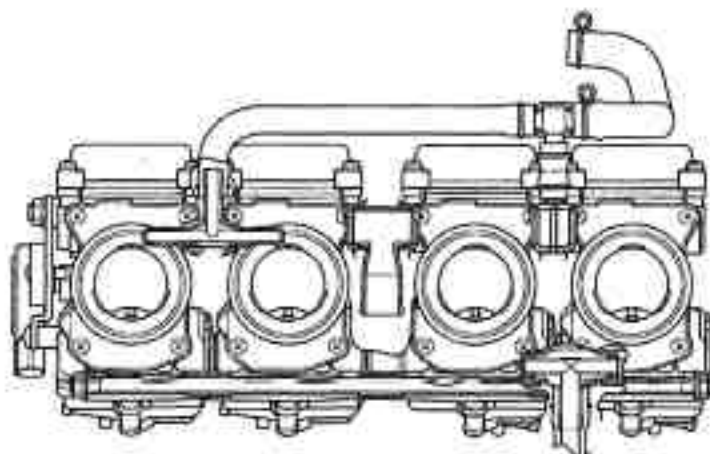
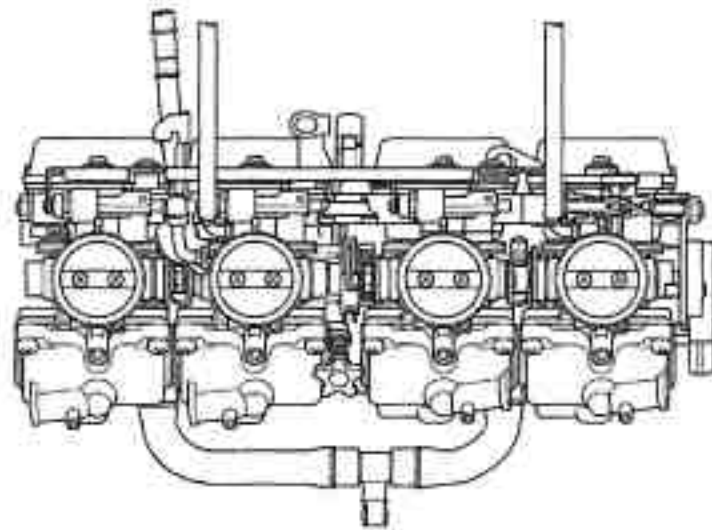

CARBURETOR HOSE ROUTING ('04 MODEL, CALIFORNIA TYPE)

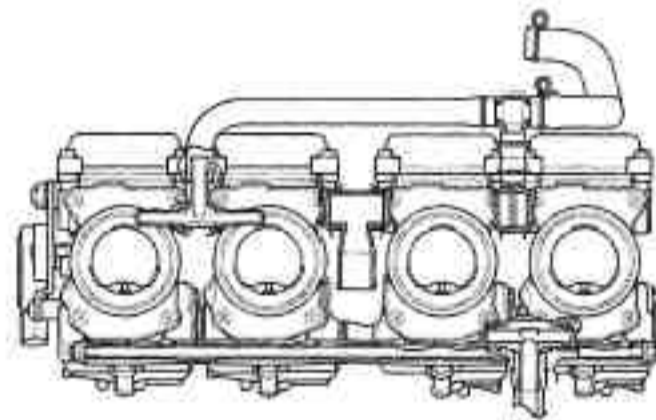
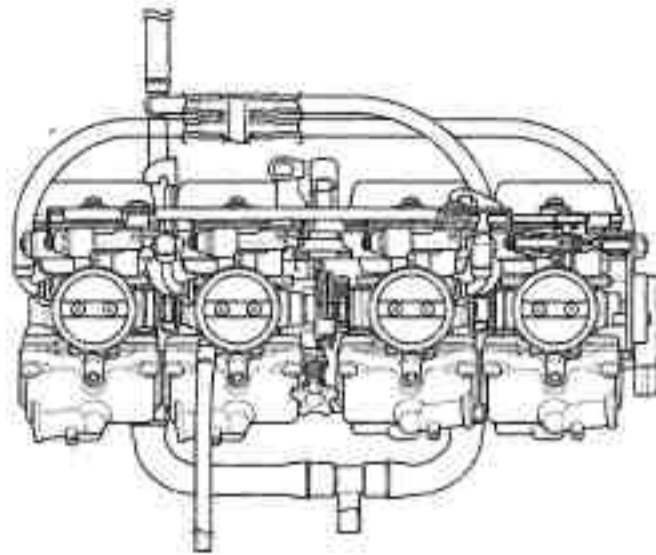

CARBURETOR HOSE ROUTING (AFTER '04 MODEL, CALIFORNIA TYPE)

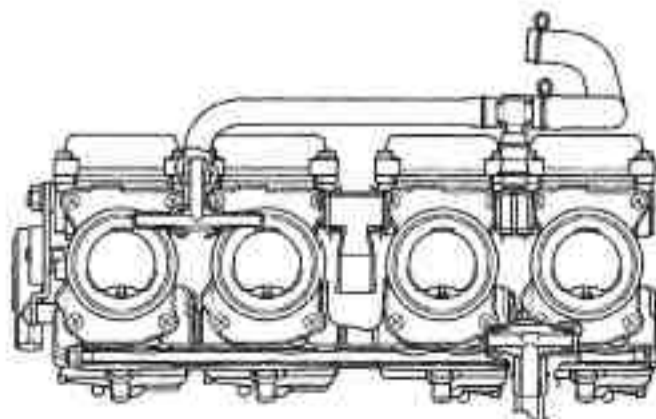
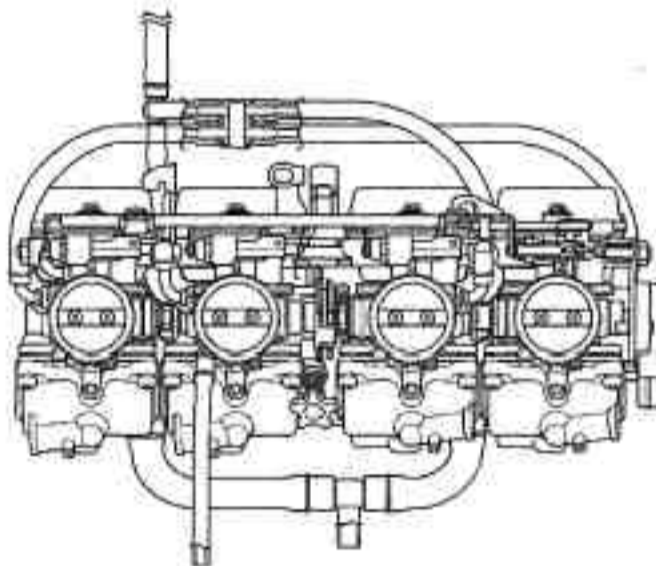

FUEL SYSTEM

CARBURETOR INSTALLATION

Connect the choke cable end to the end to the starting enrichment valve arm.

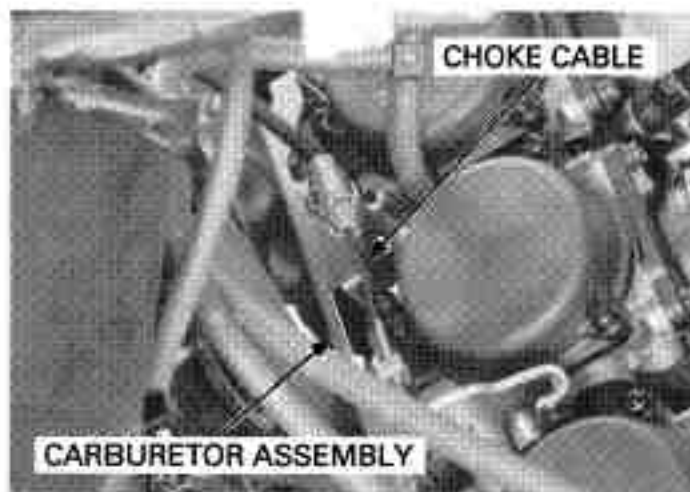

Connect the throttle cable end to the throttle drum and install the throttle cables on to the cable holder.

Coat the inside of the carburetor insulators with clean engine oil for ease of installation.

Install the carburetor assembly onto the carburetor insulators.

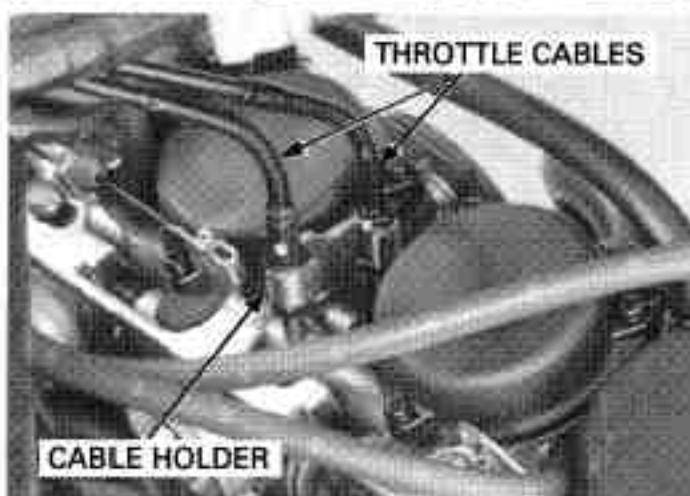

'04 model: Adjust the carburetor insulator band angle as shown.

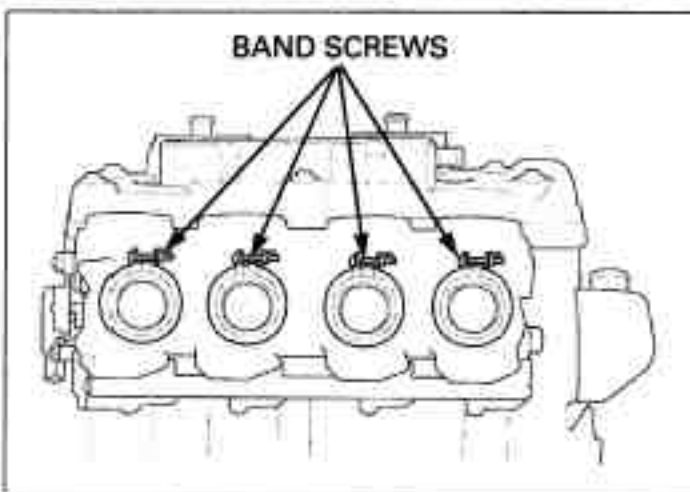

After '04 model: Adjust the carburetor insulator band angle as shown.

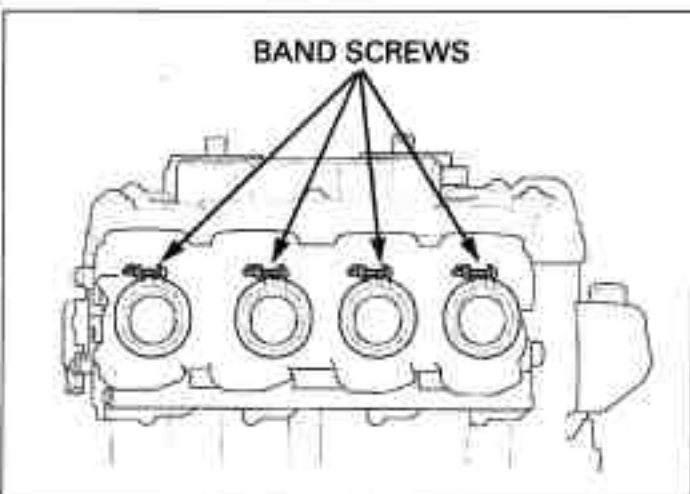

Tighten the connecting boot band screws so that the band ends clearance is 10 ± 1 mm (0.4 ± 0.04 in).

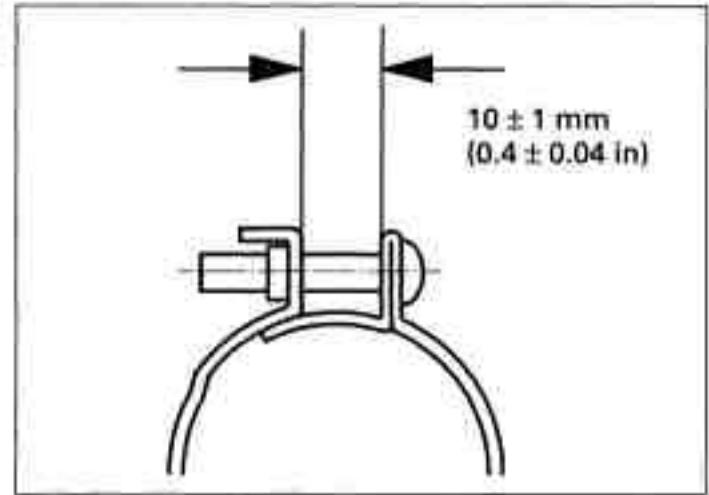

California type only: Connect the No.5 and No.11 hoses to the EVAP canister purge valve.

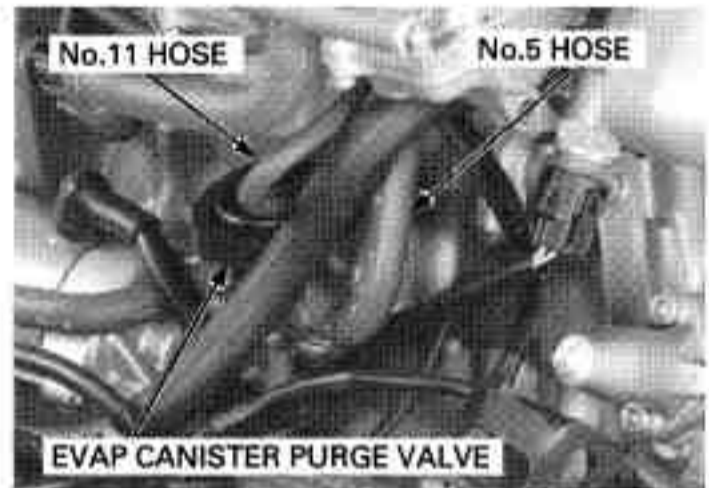

Remove the heat guard rubber.

Install the following:

- Fuel cutoff solenoid valve (page 6-42)
- EVAP CAV control valve (page 6-41)
- Air cleaner housing (page 6-7)

Perform following inspections and adjustments

- Throttle operation (page 4-5)
- Carburetor choke (page 4-6)
- Carburetor synchronization (page 4-17)
- Engine idle speed (page 4-21)
- Pilot screw (page 6-35)



PILOT SCREW ADJUSTMENT

IDLE DROP PROCEDURE

- Make sure the carburetor synchronization is within specification before pilot screw adjustment (page 4-17).
- The pilot screw are factory pre-set. Adjustment is not necessary unless the carburetors are overhauled or new pilot screws are installed.
- Use a tachometer with graduations of 50 rpm or smaller that will accurately indicate 50 rpm change.

FUEL SYSTEM

Damage to the pilot screw seat will occur if the pilot screw is tightened against the seat.

1. Turn each pilot screws clockwise until it seats lightly, then back it out the specified number of turn. This is an initial setting prior to the final pilot screw adjustment.

TOOL:

Pilot screw wrench 07KMA-MN90101 or
07PMA-MZ2011A or
07MMA-MT3010B (U.S.A. only) or
07MMA-MT3010A (U.S.A. only)

INITIAL OPENING: 2-3/8 turns out

2. Warm up the engine to operating temperature and ride the motorcycle for approximately 10 minutes.
3. Stop the engine and connect a tachometer according to the tachometer manufacture's instruction.
4. Start the engine and adjust the idle speed with the throttle stop screw.

IDLE SPEED: 1,400 ± 100 rpm

5. Turn the No.3 pilot screw in or out slowly to obtain the highest engine speed.
6. Perform step 5 for all carburetor pilot screws.
7. Lightly open the throttle 2 - 3 times, adjust the idle speed with the throttle stop screw.
8. Turn the No.3 carburetor pilot screw in gradually until the engine speed drops 50 rpm.
9. Turn the No.3 pilot screw out to the final opening from the position in step 8.

FINAL OPENING: 7/8 turn out

10. Adjust the idle speed with the throttle stop screw.
11. Perform step 8,9 and 10 for the No.1, 2 and 4 carburetor pilot screws.

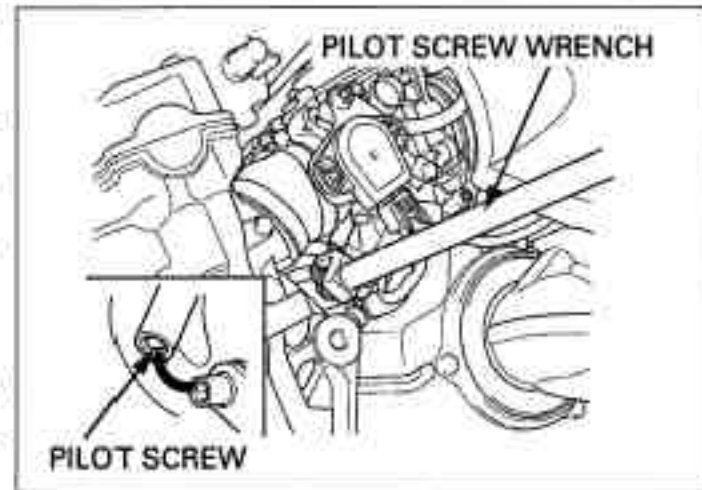
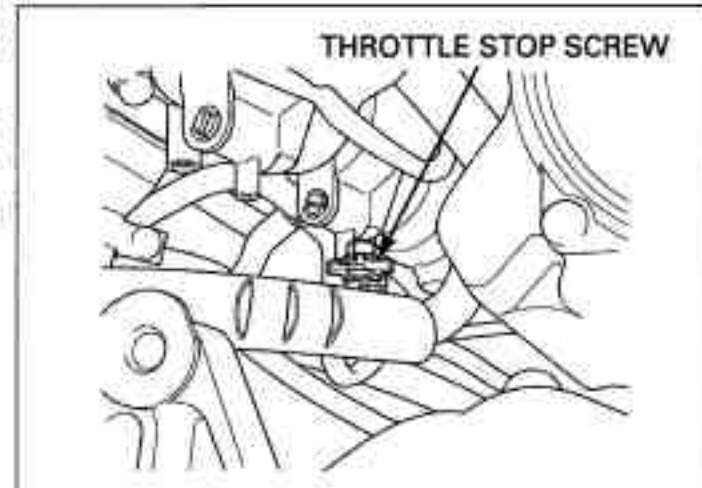
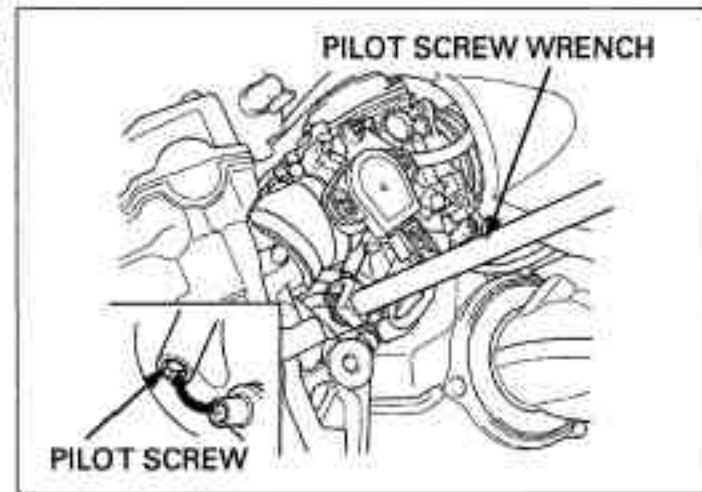

HIGH ALTITUDE ADJUSTMENT

These adjustments must be made at high altitude to ensure proper high altitude operation.

When the vehicle is to be operated continuously above 2,000 meters (6,500 feet), the carburetor must be readjusted as described below to improve driveability and decrease exhaust emissions.

Warm up the engine to operating temperature and ride the motorcycle for approximately 10 minutes.

Turn each pilot screw to the high altitude setting specified below.

TOOL:

Pilot screw wrench 07KMA-MN90101 or
07PMA-MZ2011A or
07MMA-MT3010B (U.S.A. only) or
07MMA-MT3010A (U.S.A. only)

HIGH ALTITUDE SETTING: 1/2 turn in

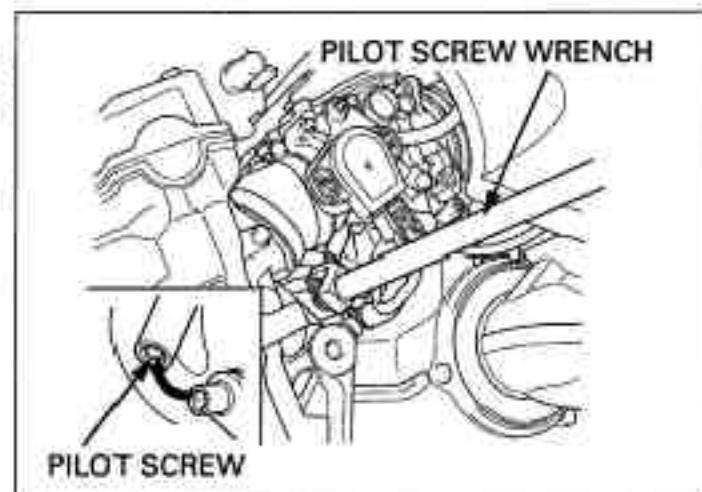

Adjust the idle speed to the specified rpm with the throttle stop screw.

IDLE SPEED: 1,400 ± 100 rpm

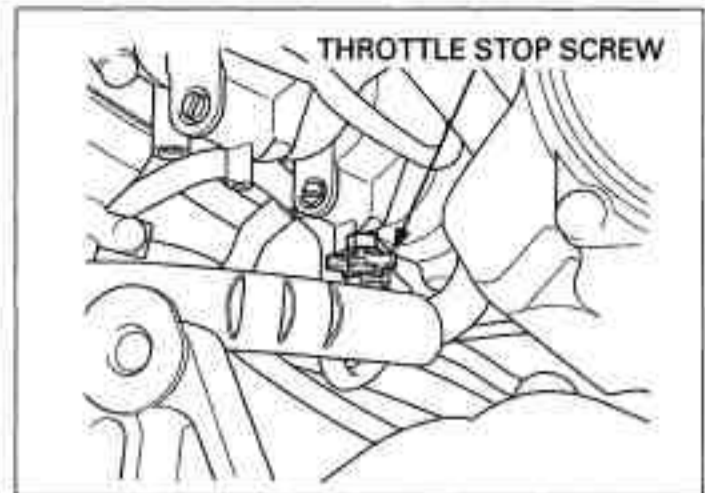

Remove the fuel tank (page 3-6).

Do not attach the label to any part that can be easily removed from the vehicle.

Attach a Vehicle Emission Control Information Update Label on the frame as shown.

NOTICE

Sustained operation at an altitude lower than 1,500 m (5,000 feet) with the carburetor adjusted for high altitude settings may cause the engine to idle roughly and stall in traffic. It may also cause engine damage due to overheating.

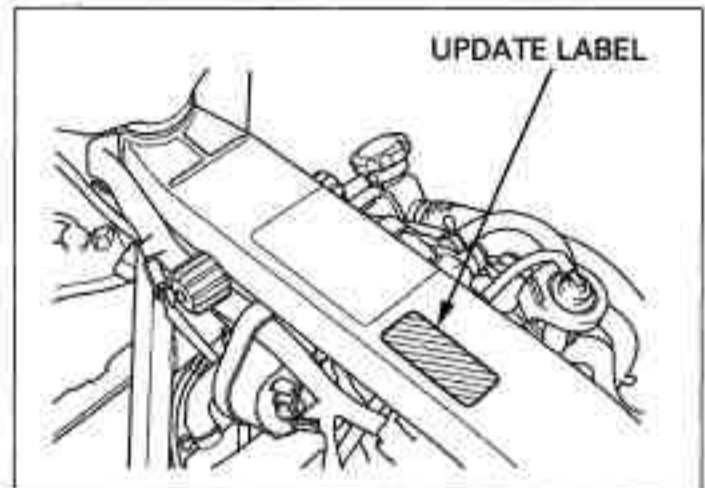

When the vehicle is to be operated continuously below 1,500 meters (5,000 feet), turn each pilot screw to be low altitude setting specified below (its original position)

LOW ALTITUDE SETTING: 1/2 turn out

Adjust the idle speed to the specified rpm (1,400 ± 100 rpm).

Be sure to do these adjustments at low altitude with the engine at normal operating temperature.

Remove the Vehicle Emission Control Information Update Label that is attached on the frame after adjusting for low altitude.

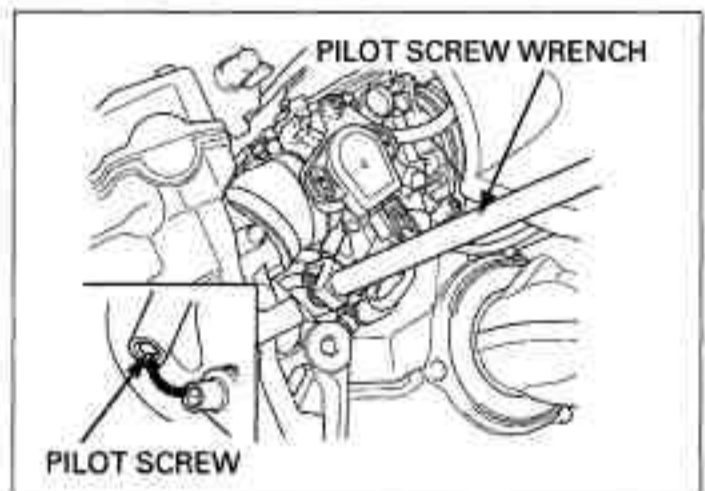

SECONDARY AIR SUPPLY SYSTEM

SYSTEM INSPECTION

Start the engine and warm it up to normal operating temperature.

Remove the air cleaner element (page 4-6).

Disconnect the PAIR air suction hose.

Check that the PAIR air suction hose port is clean and free carbon deposits.

If the port is carbon fouled, check the PAIR control valve.

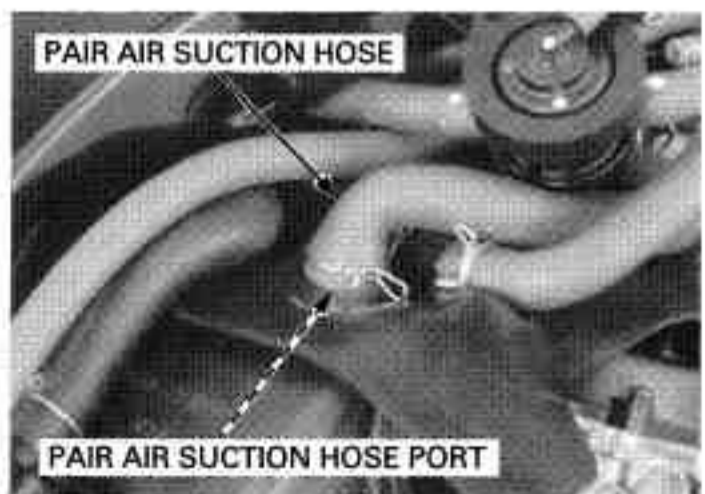

FUEL SYSTEM

Disconnect the air cleaner housing-to-PAIR control valve hose (No.15) from the air cleaner housing.

'04 model only: Disconnect the PAIR control valve vacuum hose (No.10) from the control valve and plug it to keep air from entering.

After '04 model only: Disconnect the PAIR control valve vacuum hose from the No.1 carburetor and plug it to keep air from entering.

Connect the vacuum pump to the PAIR control valve.

TOOL:

Vacuum pump **Commercially available**

Start the engine and open the throttle slightly to be certain that air is sucked in through the No.15 hose. If the air is not drawn in, check the No.15 hose for clogging.

With the engine running, gradually apply vacuum to PAIR control valve.

Check that the air intake port stops drawing air, and that the vacuum does not bleed.

SPECIFIED VACUUM: 40 mm Hg

If the air drawn in, or if the specified vacuum is not maintained, install a new PAIR control valve.

If afterburn occurs on deceleration, even when the secondary air supply system is normal, check the air cut-off valve.

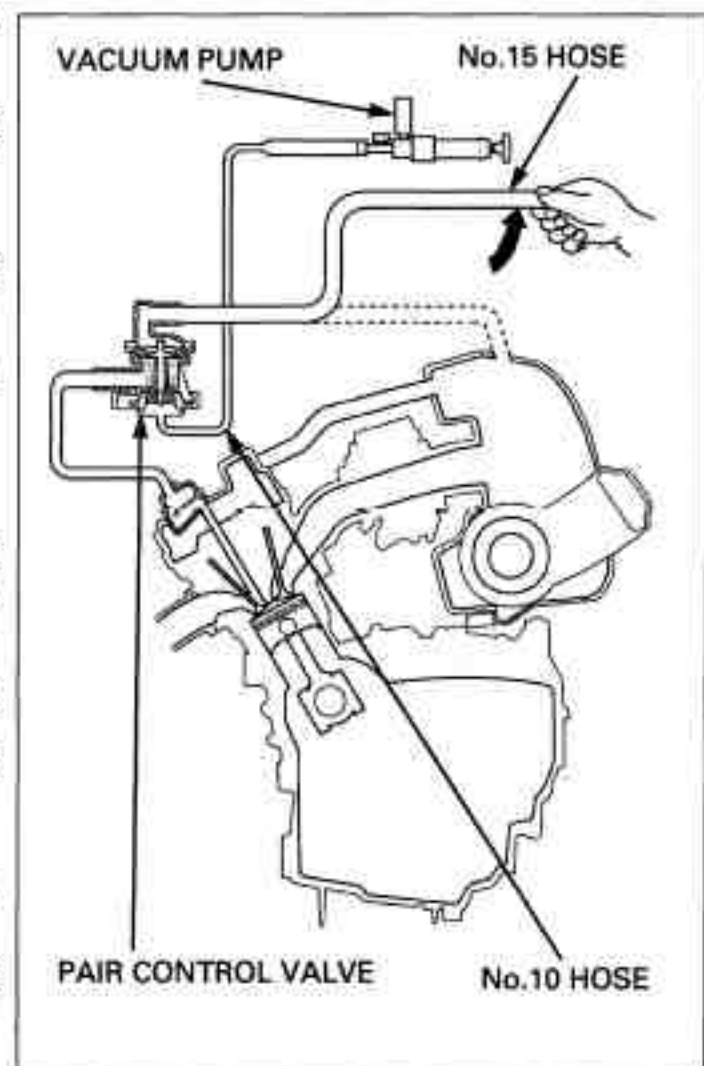

PAIR CONTROL VALVE REMOVAL/INSTALLATION

Remove the fuel tank (page 3-5).

Remove the ignition coil (page 18-10).

Disconnect PAIR control valve-to-air cleaner housing hose (No.15).

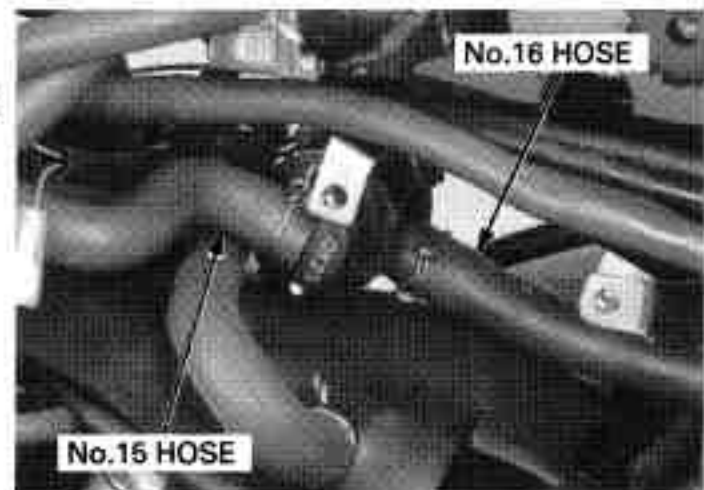

Disconnect PAIR control valve-to-cylinder head hose (No.16).

'04 model only: Disconnect PAIR control valve-to-3-way joint hose (No.10).

After '04 model only: Disconnect PAIR control valve vacuum hose from the No.1 carburetor.

Remove the PAIR control valve.

Installation is in the reverse order of removal.

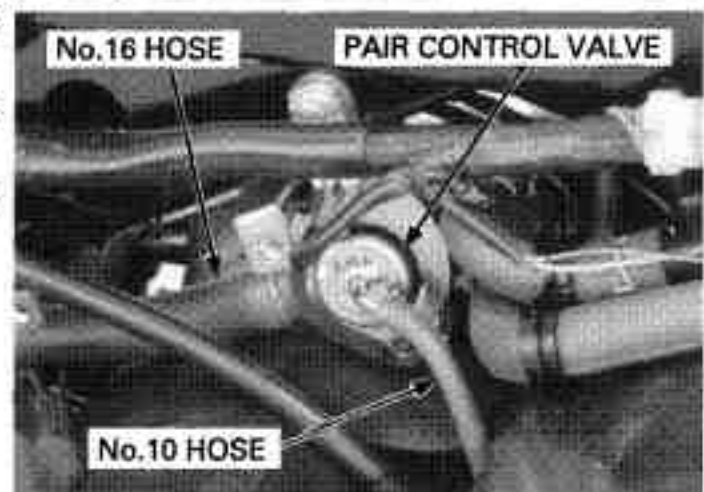

EVAPORATIVE EMISSION CONTROL SYSTEM (California type only)

- Refer to hosing diagram on page 1-40 for the hose connection.

EVAPORATIVE EMISSION (EVAP) CANISTER REMOVAL/INSTALLATION

Disconnect the EVAP purge control valve-to-canister hose (No.4).

Disconnect the fuel tank-to-Canister hose (No.1).

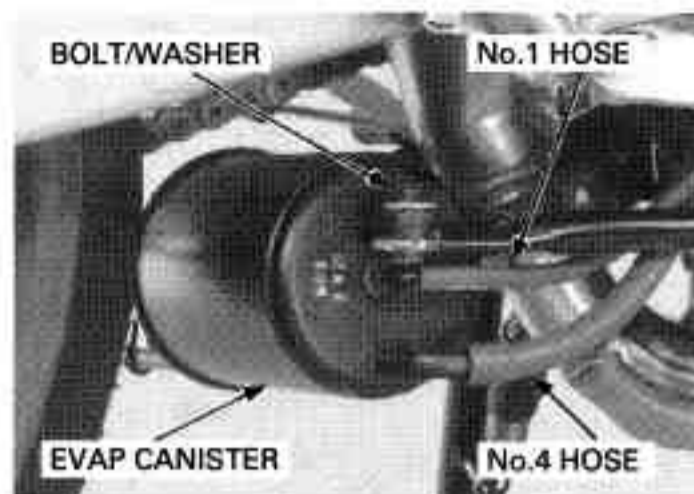

Disconnect the Canister-to-open air hose (No.2).
Remove the bolts, washers and EVAP canister.
Installation is in the reverse order of removal.

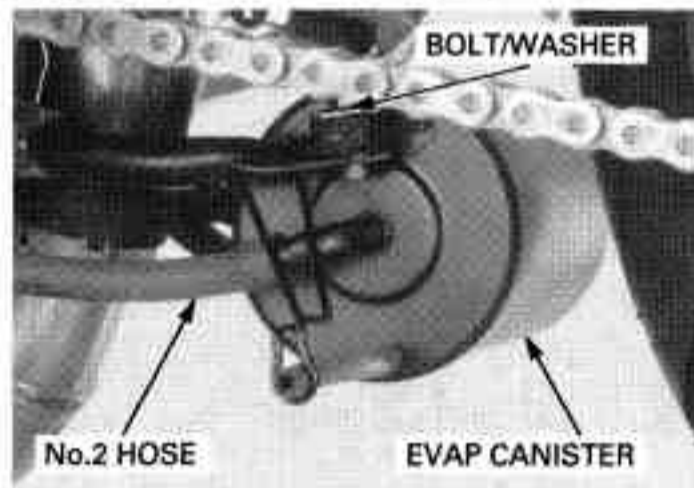

EVAPORATIVE EMISSION (EVAP) PURGE CONTROL VALVE

REMOVAL/INSTALLATION

Remove the air cleaner housing (page 6-7).
Remove the starter motor cable (page 19-6).

Disconnect the carburetor-to-EVAP purge control valve hose (No.11).

Disconnect the 5 way joint-to-EVAP purge control valve hose (No.5).

Disconnect the EVAP canister-to-EVAP purge control valve hose (No.4).

Remove the EVAP purge control valve.

Installation is in the reverse order of removal.

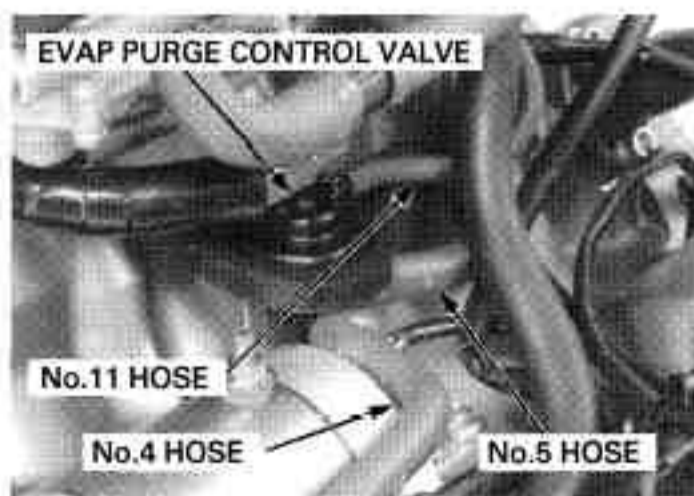

FUEL SYSTEM

INSPECTION

- The EVAP purge control valve should be inspected if hot start is difficult.

Remove the EVAP purge control valve (page 6-39).

Connect a vacuum pump to the No.5 hose fitting (output port) that goes to the 5 way joint. Apply the specified vacuum to the EVAP purge control valve.

TOOL:

Vacuum pump **Commercially available**

SPECIFIED VACUUM: 250 mm Hg

The specified vacuum should be maintained.

Replace the EVAP purge control valve if vacuum is not maintained.

Remove the vacuum pump and connect it to the No.11 hose fitting (vacuum port) which goes to the carburetor. Apply the specified vacuum to the EVAP purge control valve.

SPECIFIED VACUUM: 250 mm Hg

The specified vacuum should be maintained.

Replace the EVAP purge control valve if vacuum is not maintained.

Connect the pressure pump to the No.4 hose fitting (input port) which goes to the EVAP canister.

NOTICE

Damage to the EVAP purge control valve may result from use of a high pressure air source. Use a hand operated air pump only.

While applying the specified vacuum to the EVAP purge control valve vacuum port, pump air through the input port.

SPECIFIED VACUUM: 250 mm Hg

Air should flow through the EVAP purge control valve and out the output port that goes to the carburetors.

Replace the EVAP purge control valve if air does not flow out.

Remove the pumps and install the EVAP purge control valve in the reverse order of removal.

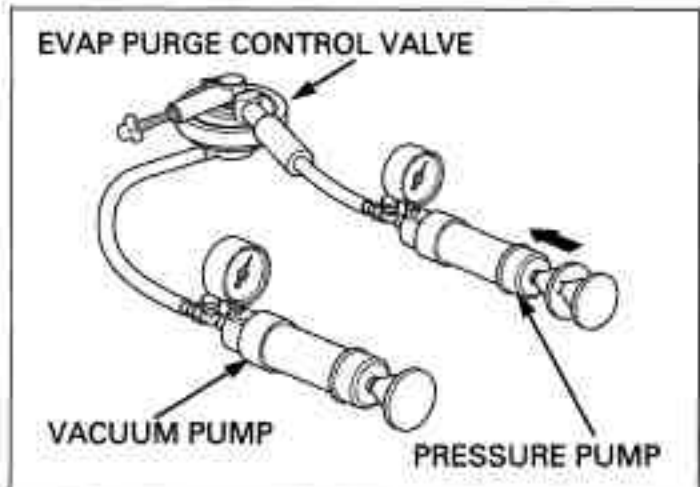
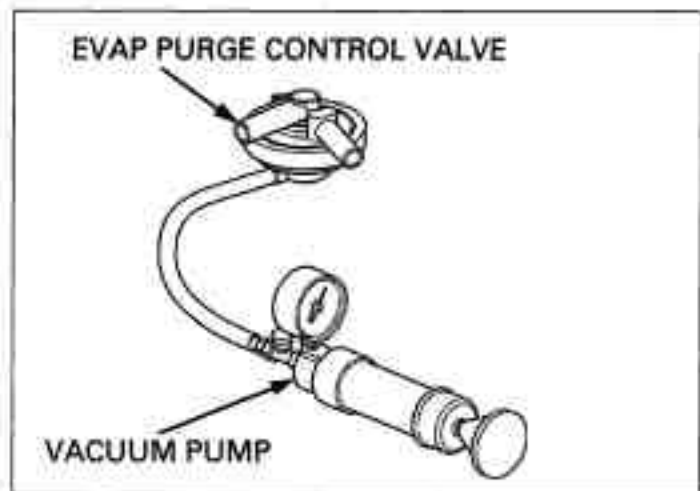
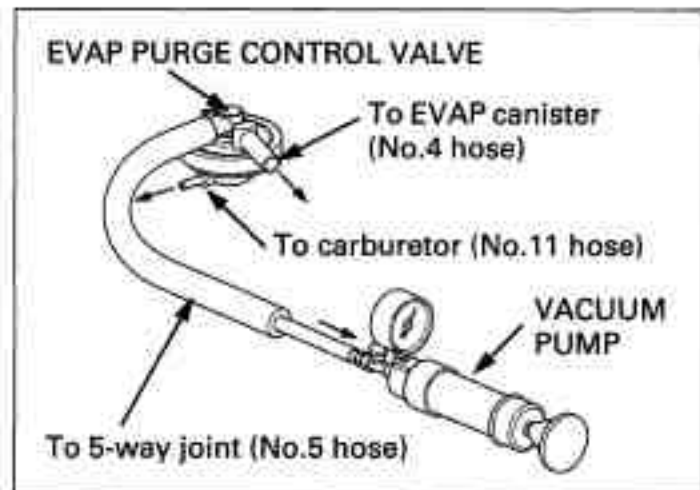

**EVAPORATIVE EMISSION
CARBURETOR AIR VENT (EVAP CAV)
CONTROL VALVE**

REMOVAL/INSTALLATION

Remove the fuel tank (page 3-6).

'04 model only: Disconnect the No.4 vacuum port-to-EVAP CAV control valve hose (No.10).

After '04 model only: Disconnect the No.4 carburetor-to-EVAP CAV control valve vacuum hose.

Disconnect the fuel cutoff solenoid valve-to-EVAP CAV control valve hose (No.6).

Disconnect the EVAP canister-to-EVAP CAV control valve hose (No.4).

Remove the EVAP CAV control valve from the frame.

Disconnect the sub-air cleaner housing-to-EVAP CAV control valve hose (No.7).

Installation is in the reverse order of removal.

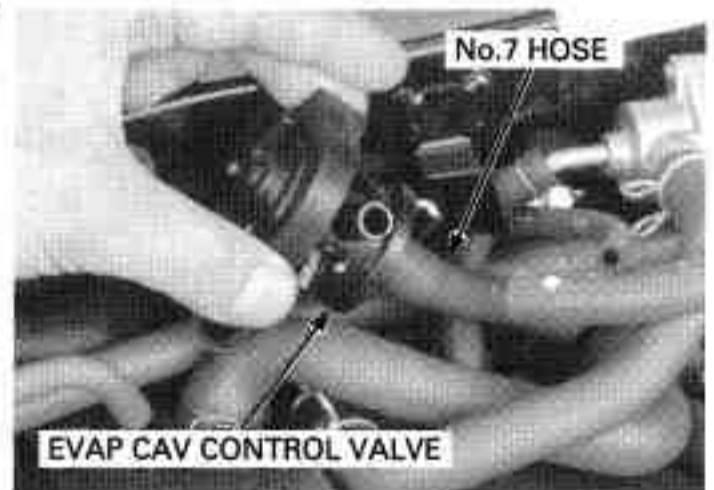
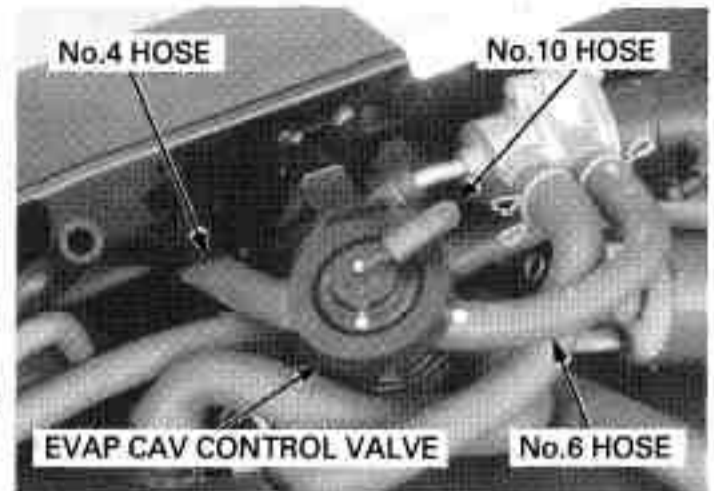

INSPECTION

- The EVAP CAV control valve should be inspected if hot start is difficult.

Remove the EVAP CAV control valve (page 6-41).

'04 model only: Connect a vacuum pump to the No.10 hose fitting (vacuum port) that goes to the No.4 vacuum port.

After '04 model only: Connect a vacuum pump to the No.10 hose fitting that goes to the No.4 carburetor.

Apply the specified vacuum to the EVAP CAV control valve.

TOOL:

Vacuum pump **Commercially available**

SPECIFIED VACUUM: 250 mm Hg

The specified vacuum should be maintained.

Replace the EVAP CAV control valve if vacuum is not maintained.

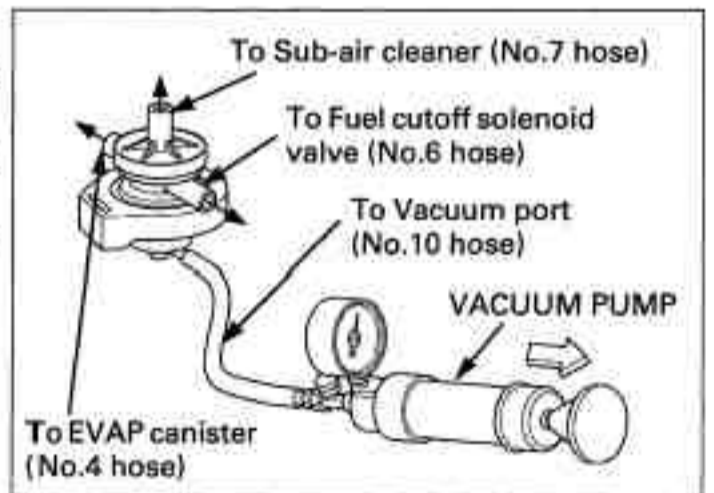

FUEL SYSTEM

Remove the vacuum pump and connect it to the No.7 hose fitting that goes to the air cleaner housing. Apply the specified vacuum to the EVAP CAV control valve. The vacuum should hold steady. Replace the EVAP CAV control valve if vacuum leaks. Remove the vacuum pump and reconnect it to the No.10 hose fitting (Vacuum port).

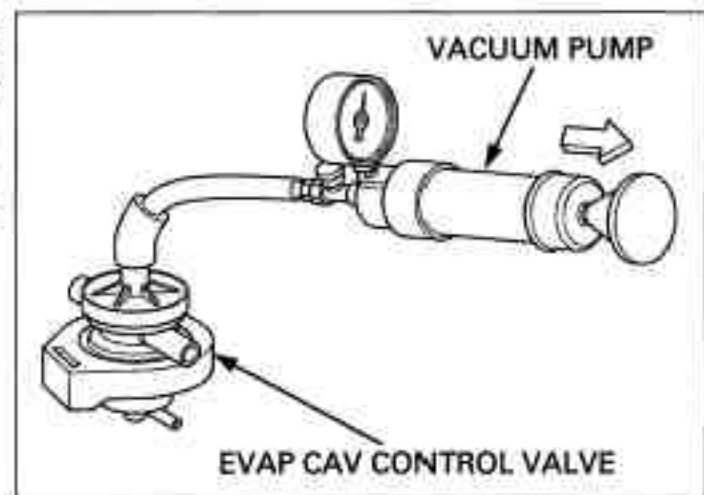

Connect the pressure pump to the No.7 hose fitting that goes to the air cleaner housing.

NOTICE

Damage to the EVAP CAV control valve may result from use of a high pressure air source. Use a hand operated air pump only.

While applying the specified vacuum to the EVAP CAV control valve vacuum port, pump air through the air cleaner housing port.

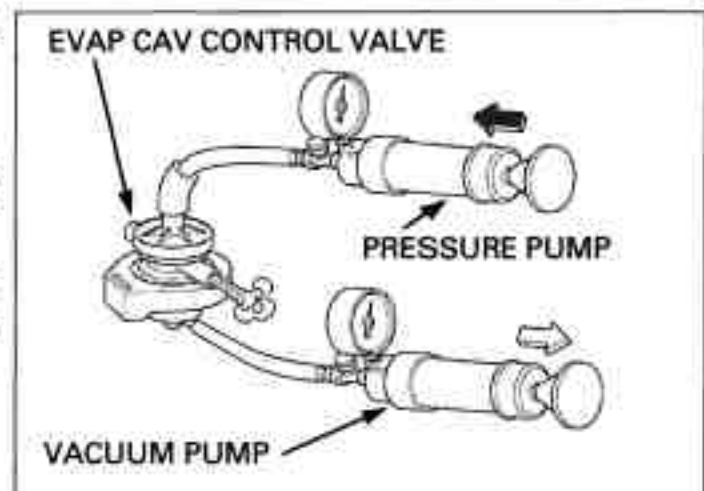

Plug the No.6 hose fitting that goes to the PAIR solenoid valve.

While applying vacuum to the vacuum port, apply air it should hold steady. Replace the EVAP CAV control valve if pressure is not retained.

Remove the pumps and install the EVAP CAV control valve in the reverse order of removal.

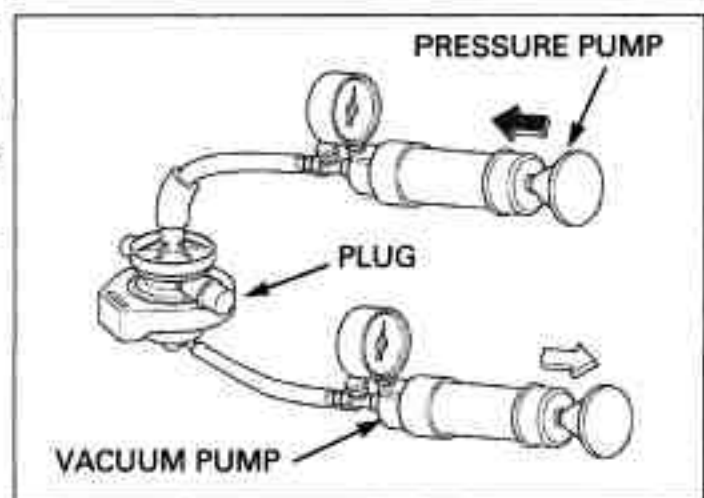

FUEL CUTOFF SOLENOID VALVE ('04 California type and after '04 model)

REMOVAL/INSTALLATION

Remove the fuel tank (page 3-6).

Disconnect the fuel cutoff solenoid valve 2P (White) connector.

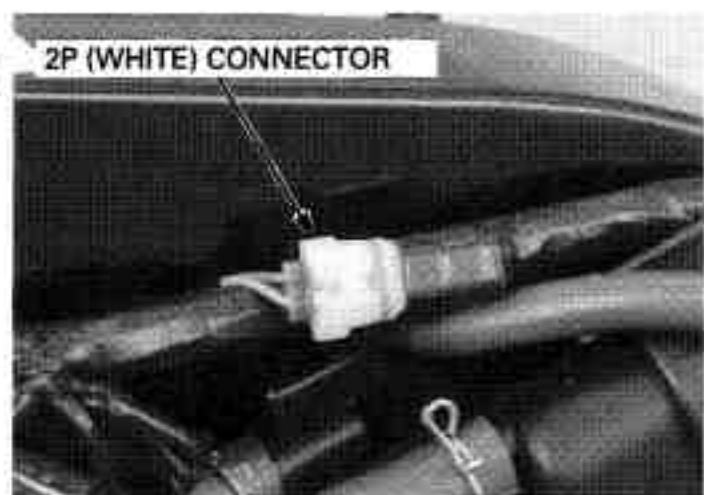

California type only: Disconnect the fuel cutoff solenoid valve-to-EVAP CAV control valve hose (No.6).

Disconnect the fuel cutoff solenoid valve-to-3-way joint (No.6).

Disconnect the fuel cutoff solenoid valve-to-5-way joint hose (No.5).

Remove the fuel cutoff solenoid valve.

Installation is in the reverse order of removal.

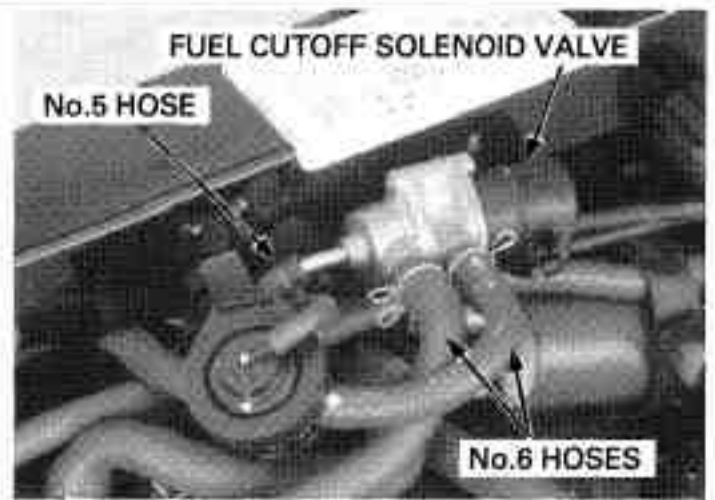

After '04 model (Except California type) only: Disconnect the fuel cutoff solenoid valve-to-the sub air cleaner hose.

Disconnect the fuel cutoff solenoid valve-to-3-way joint (No.6).

Disconnect the fuel cutoff solenoid valve-to-the No.3 carburetor hose (fuel cutoff solenoid vacuum hose).

Remove the fuel cutoff solenoid valve.

Installation is in the reverse order of removal.

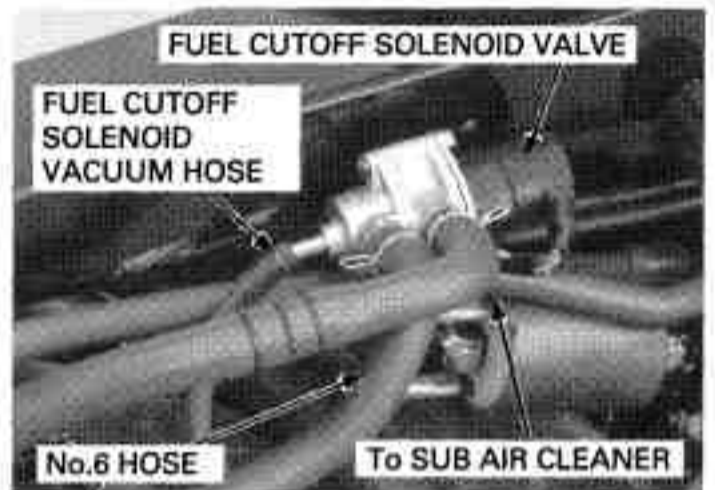

INSPECTION

Remove the fuel cutoff solenoid valve (page 6-42).

Connect a vacuum pump to the No.5 hose fitting that goes to the 5-way joint. Apply the specified vacuum to the fuel cutoff solenoid valve.

TOOL:

Vacuum pump **Commercially available**

SPECIFIED VACUUM: 250 mm Hg

The specified vacuum should be maintained.

Replace the fuel cutoff solenoid valve if vacuum is not maintained.

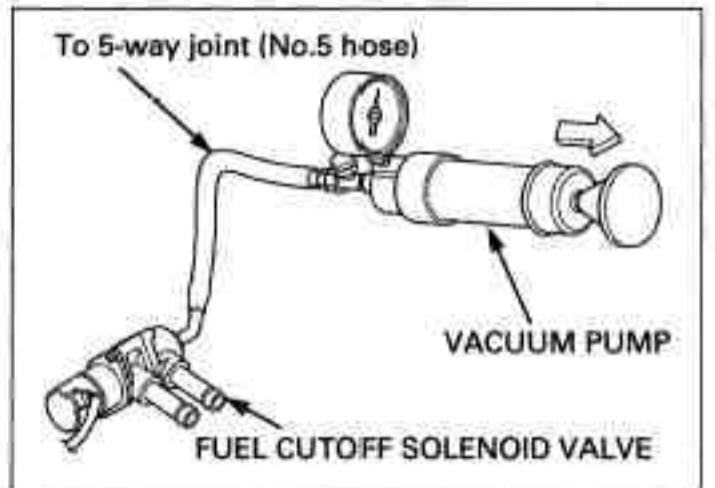

Remove the vacuum pump.

Connect the pressure pump to the No.6 hose fitting that goes to the 3-way joint.

NOTICE

Damage to the fuel cutoff solenoid valve may result from use of a high pressure air source. Use a hand operated air pump only.

Pump air through the EVAP CAV control valve port.

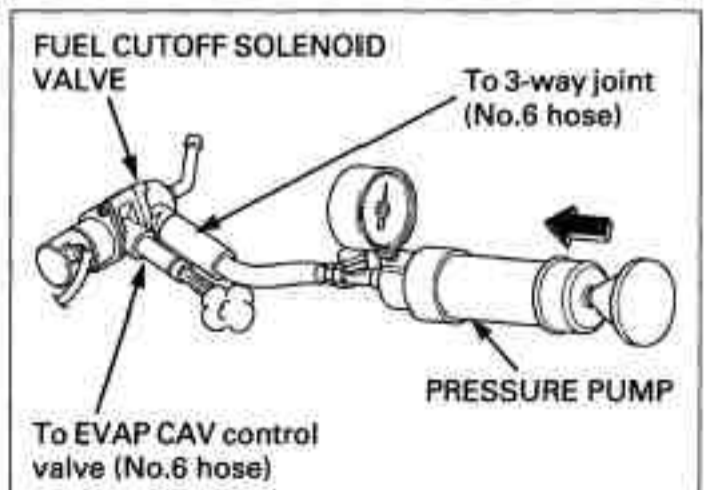

FUEL SYSTEM

Remove the pressure pump and connect it to the No.6 hose fitting that goes to the EVAP CAV control valve.

NOTICE

Damage to the fuel cutoff solenoid valve may result from use of a high pressure air source. Use a hand operated air pump only.

Pump air through the 3-way joint port.

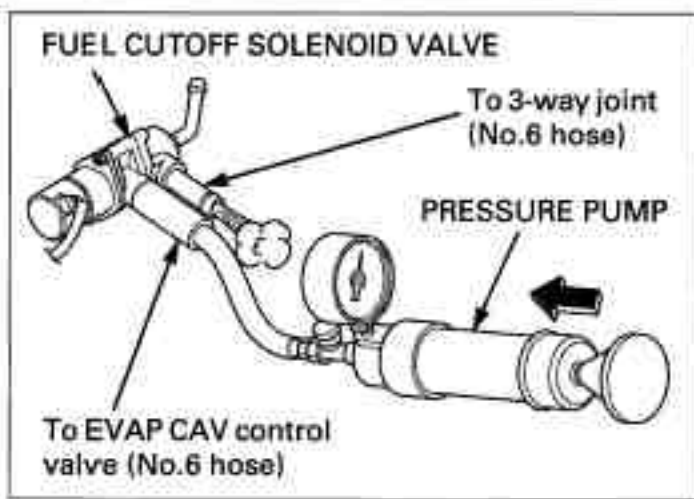

Connect the 12V battery to the fuel cutoff solenoid valve 2P (Black) connector terminals.

Connect a vacuum pump to the No.6 hose fitting that goes to the EVAP CAV control valve. Apply the specified vacuum to the fuel cutoff solenoid valve.

SPECIFIED VACUUM: 250 mm Hg

The specified vacuum should be maintained.

Replace the fuel cutoff solenoid valve if vacuum is not maintained.

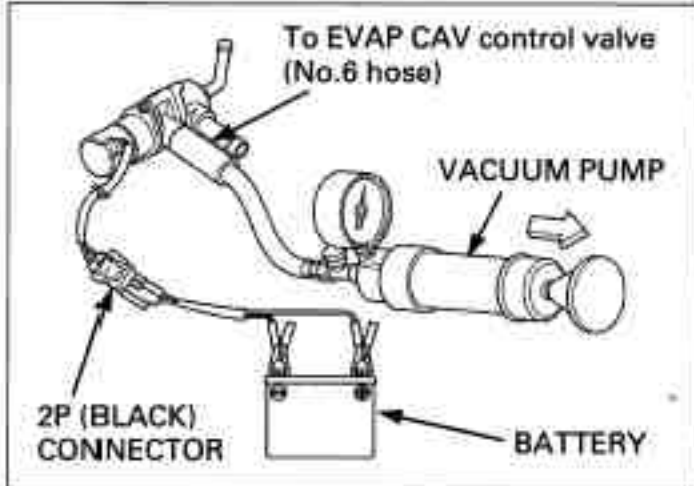

Remove the pressure pump and connect it to the No.5 hose fitting that goes to the 5-way joint.

NOTICE

Damage to the fuel cutoff solenoid valve may result from use of a high pressure air source. Use a hand operated air pump only.

Pump air through the 3-way joint port.

Replace the fuel cutoff solenoid valve if necessary.

Remove the pressure pump and install the fuel cut-off solenoid valve in the reverse order of removal.

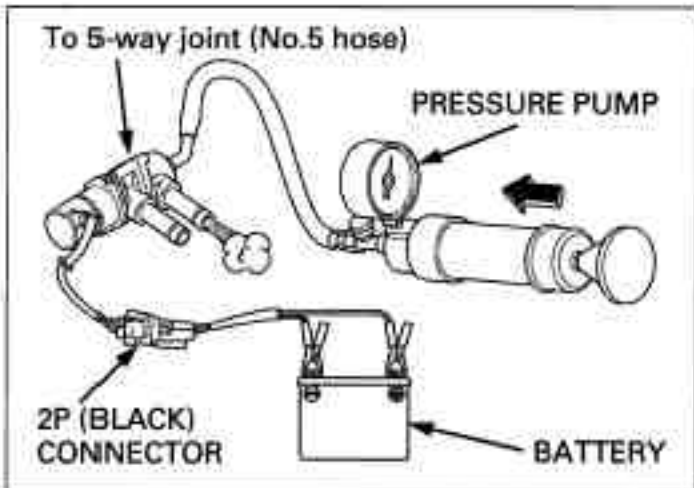

FUEL VALVE

INSPECTION

Remove the fuel tank (page 3-6).

Connect the fuel hose to the fuel valve and place a suitable gasoline container under the fuel hose.

Turn the fuel valve on.

If the fuel flows out of the fuel hose, replace the fuel valve diaphragm.

Connect a commercially available vacuum pump to the fuel valve vacuum hose.

Fuel should flow out from the fuel hose when vacuum is applied.

If the fuel flow is restricted, replace the fuel valve diaphragm.

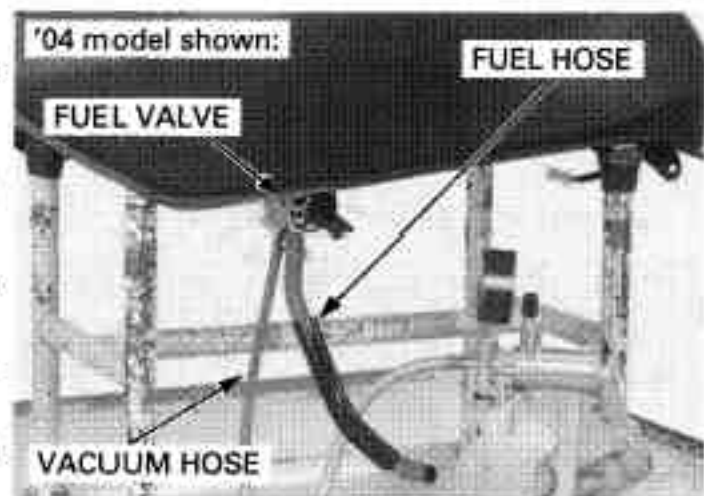

REMOVAL

Drain the fuel from the fuel tank.
Remove the screws and diaphragm cover.

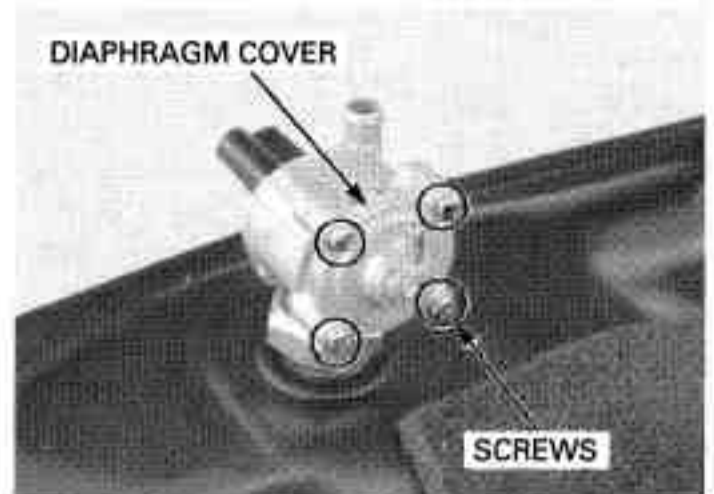

Remove the spring and diaphragm/spacer.

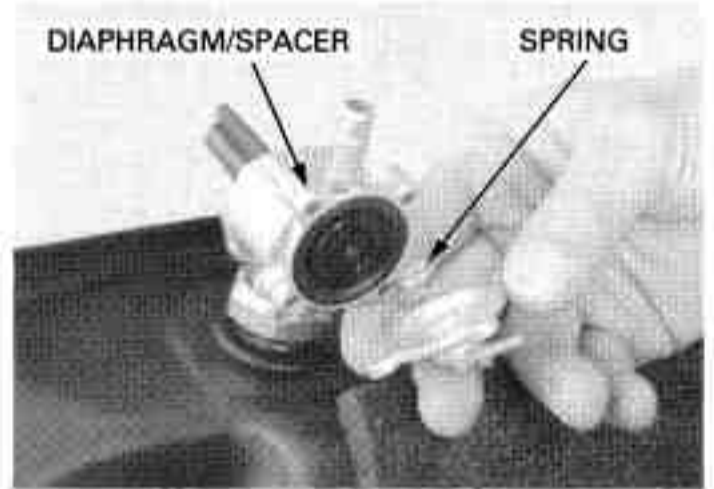

Replace the diaphragm cover, spring, diaphragm/spacer as a set.

Check the diaphragm for tears or other damage.
Replace if necessary.

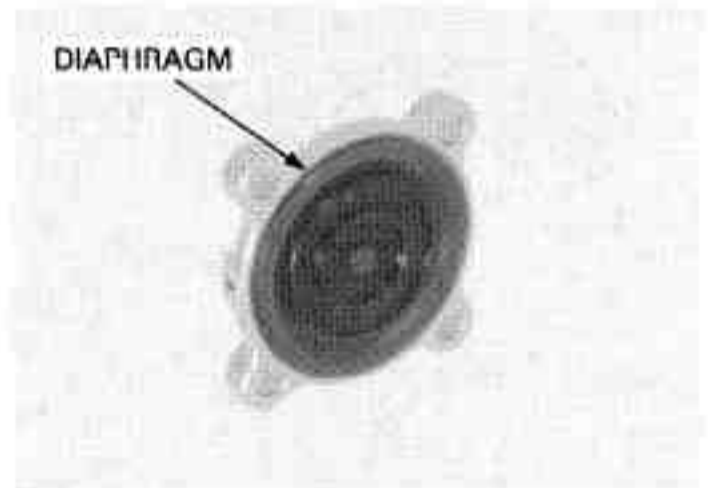

Loosen the nut and remove the fuel valve assembly from the fuel tank.

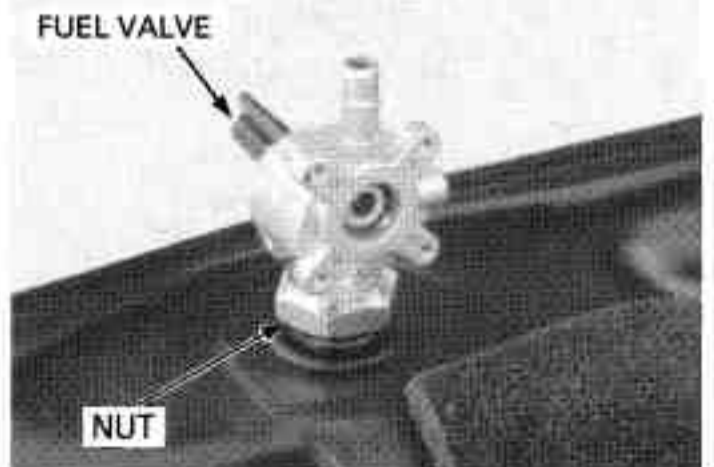

FUEL SYSTEM

Remove the fuel strainer and O-ring from the fuel valve.
Clean the fuel strainer with compressed air.

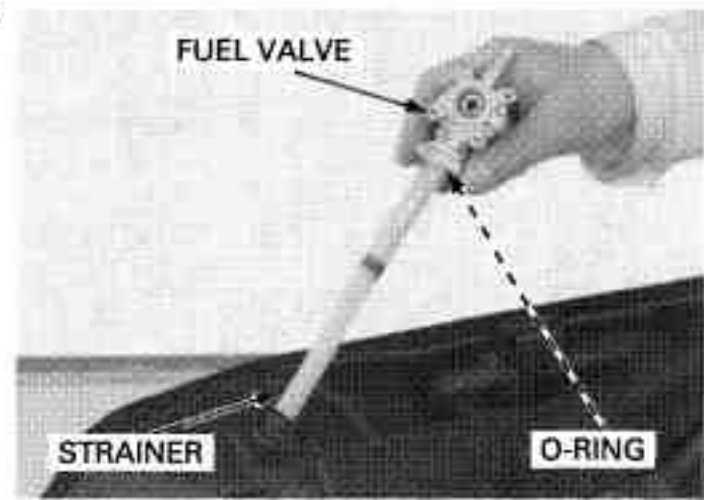

ASSEMBLY

Install a new O-ring and fuel strainer onto a fuel valve.

'04 model shown:

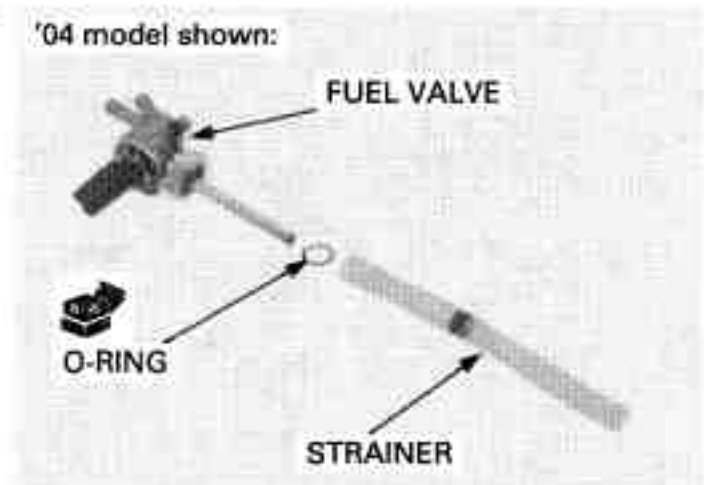

Install the fuel valve into the fuel tank.
Tighten the fuel valve nut to the specified torque.

TORQUE: 34 N·m (3.5 kgf·m, 25 lbf·ft)

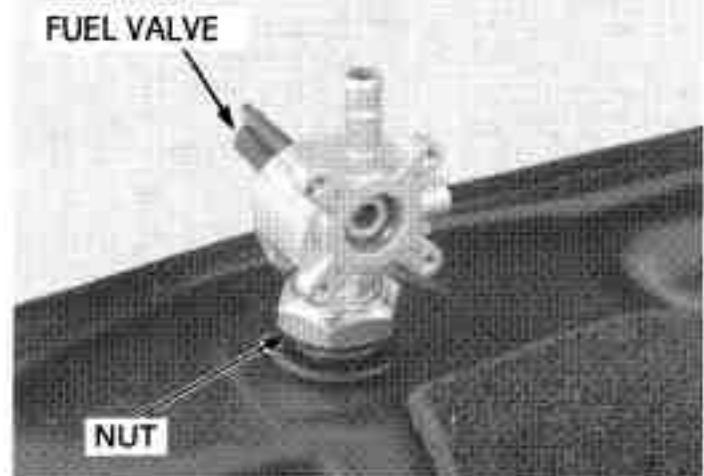

Install the diaphragm/spacer, spring and diaphragm cover so that the air vent hole of the spacer and vacuum pipe of the cover facing to the same direction as the fuel pipe of the fuel valve body.

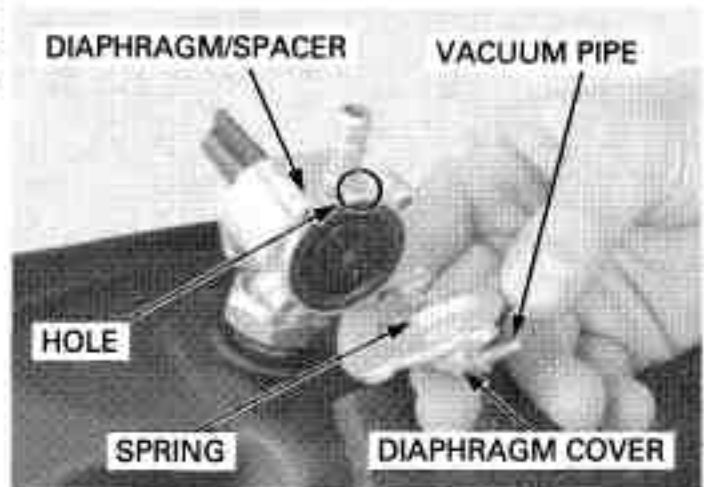

Install and tighten the screws securely.

Install the fuel tank (page 3-6).

Fill the fuel tank and make sure there are no fuel leaks.

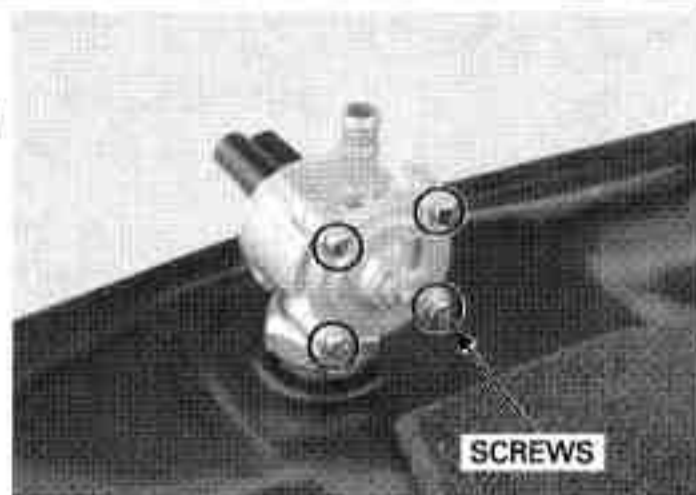

7. COOLING SYSTEM

SYSTEM FLOW PATTERN	7-2	THERMOSTAT	7-8
SERVICE INFORMATION	7-3	RADIATOR	7-10
TROUBLESHOOTING	7-4	RADIATOR RESERVE TANK	7-16
SYSTEM TESTING	7-5	WATER PUMP	7-17
COOLANT REPLACEMENT	7-6		

COOLING SYSTEM

SYSTEM FLOW PATTERN

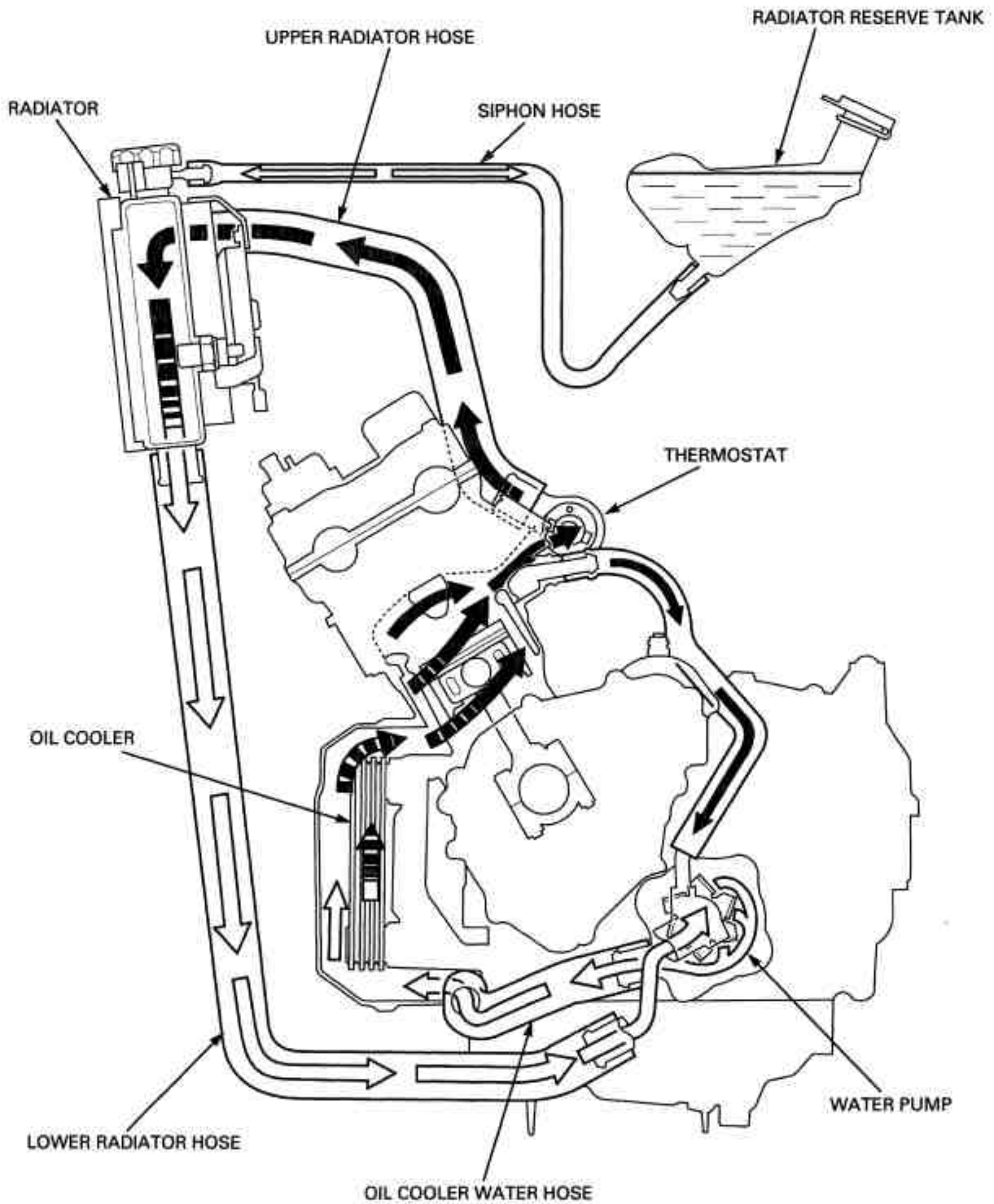

SERVICE INFORMATION

GENERAL

▲ WARNING

Removing the radiator cap while the engine is hot can allow the coolant to spray out, seriously scalding you. Always let the engine and radiator cool down before removing the radiator cap.

NOTICE

Using coolant with silicate inhibitors may cause premature wear of water pump seals or blockage of radiator passages. Using tap water may cause engine damage.

- Add cooling system at the reserve tank. Do not remove the radiator cap except to refill or drain the system.
- All cooling system services can be done with the engine in the frame.
- Avoid spilling coolant on painted surfaces.
- After servicing the system, check for leaks with a cooling system tester
- Refer to the fan motor switch inspection and ECT sensor inspection (page 20-19).

SPECIFICATIONS

ITEM		SPECIFICATIONS
Coolant capacity	Radiator and engine	2.3 liter (2.43 US qt, 2.02 Imp qt)
	Reserve tank	0.30 liter (0.32 US qt, 0.26 Imp qt)
Radiator cap relief pressure		108 – 137 kPa (1.1 – 1.4 kgf/cm ² , 16 – 20 psi)
Thermostat	Begin to open	80 – 84 °C (176 – 183 °F)
	Fully open	95 °C (203 °F)
	Valve lift	8 mm (0.3 in) minimum
Recommended antifreeze		High quality ethylene glycol antifreeze containing corrosion protection inhibitors
Standard coolant concentration		1:1 mixture with soft water

TORQUE VALUES

Water pump cover bolt	13 N·m (1.3 kgf·m, 9 lbf·ft)	CT bolt
ECT sensor	23 N·m (2.3 kgf·m, 17 lbf·ft)	
Water hose joint	29 N·m (3.0 kgf·m, 22 lbf·ft)	
Fan motor switch	18 N·m (1.8 kgf·m, 13 lbf·ft)	Apply sealant to the threads
Fan motor mounting nut	5.1 N·m (0.52 kgf·m, 3.8 lbf·ft)	
Cooling fan nut	2.7 N·m (0.28 kgf·m, 2.0 lbf·ft)	Apply a locking agent to the threads

COOLING SYSTEM

TROUBLESHOOTING

Engine temperature too high

- Faulty temperature gauge or ECT sensor
- Thermostat stuck closed
- Faulty radiator cap
- Insufficient coolant
- Passage blocked in radiator, hoses or water jacket
- Air in system
- Faulty cooling fan motor
- Faulty fan motor switch
- Faulty water pump

Engine temperature too low

- Faulty temperature gauge or ECT sensor
- Thermostat stuck open
- Faulty cooling fan motor switch

Coolant leak

- Faulty water pump mechanical seal
- Deteriorated O-rings
- Faulty radiator cap
- Damaged or deteriorated cylinder head gasket
- Loose hose connection or clamp
- Damaged or deteriorated hose

SYSTEM TESTING

COOLANT (HYDROMETER TEST)

Remove the screw and radiator cap.

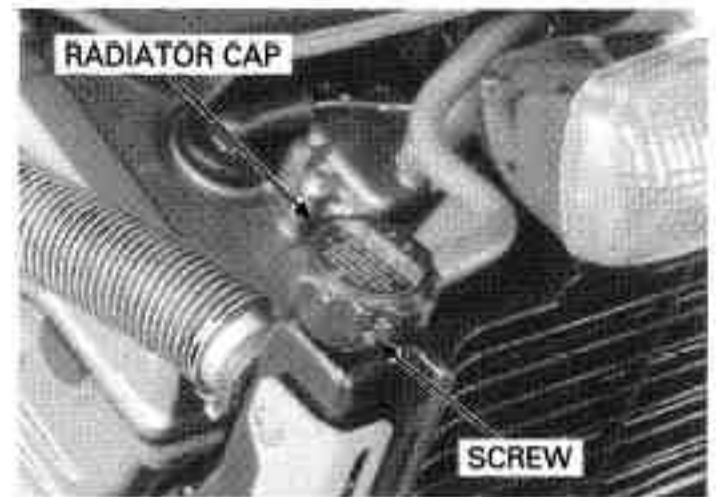

Test the coolant gravity using a hydrometer (see below for "Coolant gravity chart"). For maximum corrosion protection, a 50 – 50% solution of ethylene glycol and distilled water is recommended (page 7-6). Look for contamination and replace the coolant if necessary.



COOLANT GRAVITY CHART

		Coolant temperature °C (°F)										
		0 (32)	5 (41)	10 (50)	15 (59)	20 (68)	25 (77)	30 (86)	35 (95)	40 (104)	45 (113)	50 (122)
Coolant ratio%	5	1.009	1.009	1.008	1.008	1.007	1.006	1.005	1.003	1.001	0.999	0.997
	10	1.018	1.017	1.017	1.016	1.015	1.014	1.013	1.011	1.009	1.007	1.005
	15	1.028	1.027	1.026	1.025	1.024	1.022	1.020	1.018	1.016	1.014	1.012
	20	1.036	1.035	1.034	1.033	1.031	1.029	1.027	1.025	1.023	1.021	1.019
	25	1.045	1.044	1.043	1.042	1.040	1.038	1.036	1.034	1.031	1.028	1.025
	30	1.053	1.052	1.051	1.047	1.046	1.045	1.043	1.041	1.038	1.035	1.032
	35	1.063	1.062	1.060	1.058	1.056	1.054	1.052	1.049	1.046	1.043	1.040
	40	1.072	1.070	1.068	1.066	1.064	1.062	1.059	1.056	1.053	1.050	1.047
	45	1.080	1.078	1.076	1.074	1.072	1.069	1.066	1.063	1.060	1.057	1.054
	50	1.086	1.084	1.082	1.080	1.077	1.074	1.071	1.068	1.065	1.062	1.059
	55	1.095	1.093	1.091	1.088	1.085	1.082	1.079	1.076	1.073	1.070	1.067
	60	1.100	1.098	1.095	1.092	1.089	1.086	1.083	1.080	1.077	1.074	1.071

COOLING SYSTEM

RADIATOR CAP/SYSTEM PRESSURE INSPECTION

Before installing the cap in the tester, wet the sealing surfaces.

Remove the radiator cap (page 7-5).

Pressure test the radiator cap.

Replace the radiator cap if it does not hold pressure, or if relief pressure is too high or too low. It must hold specified pressure for at least 6 seconds.

RADIATOR CAP RELIEF PRESSURE:

108 – 137 kPa (1.1 – 1.4 kgf/cm², 16 – 20 psi)

Pressure the radiator, engine and hoses, and check for leaks.

NOTICE

Excessive pressure can damage the cooling system components. Do not exceed 137 kPa (1.4 kgf/cm², 20 psi).

Repair or replace components if the system will not hold specified pressure for at least 6 seconds.



COOLANT REPLACEMENT

PREPARATION

- The effectiveness of coolant decreases with the accumulation of rust or if there is a change in the mixing proportion during usage. Therefore, for best performance change the coolant regularly as specified in the maintenance schedule.
- Mix only distilled, low mineral water with the antifreeze.

RECOMMENDED ANTIFREEZE:

High quality ethylene glycol antifreeze containing corrosion protection inhibitors

RECOMMENDED MIXTURE:

1:1 (Distilled water and antifreeze)

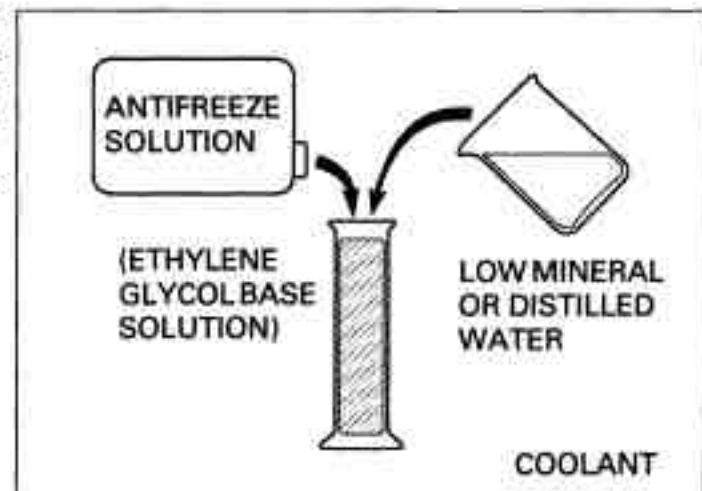

When filling the system or reserve tank with a coolant (checking coolant level), place the motorcycle in a vertical position on a flat, level surface.

REPLACEMENT/AIR BLEEDING

Remove the screw and radiator cap.

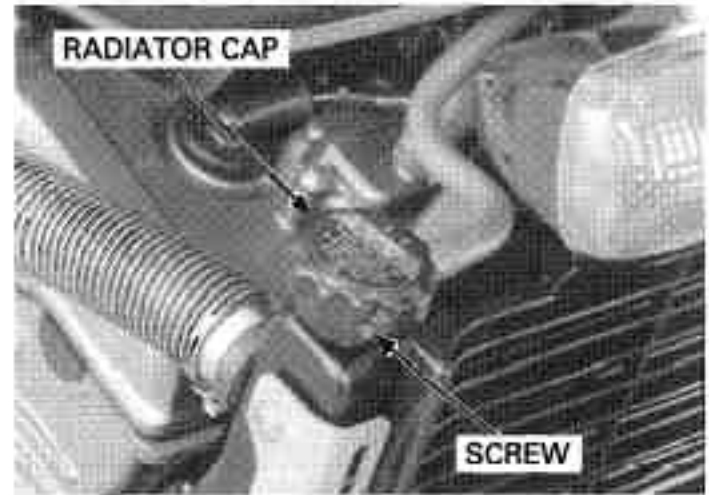

Remove the drain bolt on the water pump cover and drain the system coolant.

Reinstall the drain bolt with the new sealing washer. Tighten the water pump drain bolt securely.

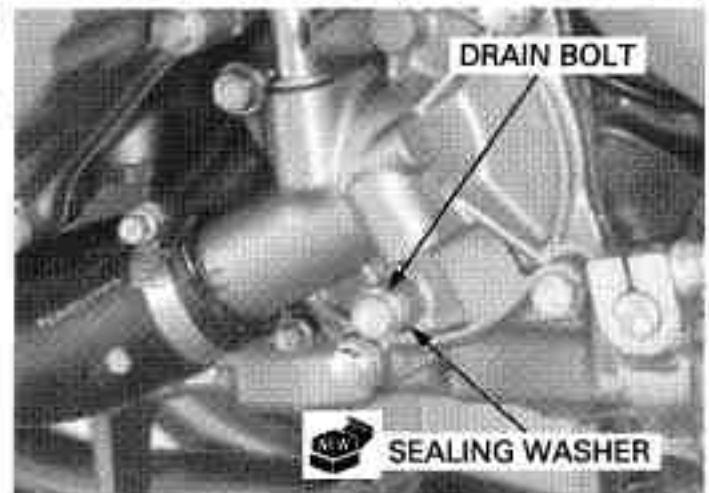

Remove the rear fender (page 3-8).

Remove the fuse box.

Disconnect the siphon hose from the reserve tank and drain the reserve tank coolant. Empty the coolant and rinse the inside of the reserve tank with water.

Connect the siphon hose to the reserve tank.



Fill the system with the recommended coolant through the filler opening up to filler neck.



COOLING SYSTEM

Remove the radiator reserve tank cap and fill the reserve tank to the upper level line.

Bleed air from the system as follow:

1. Shift the transmission into neutral. Start the engine and let it idle for 2 – 3 minutes.
2. Snap the throttle 3 – 4 times to bleed air from the system.
3. Stop the engine and add coolant up to the proper level if necessary. Reinstall the radiator cap.
4. Check the level of coolant in the reserve tank and fill to the upper level if it is low.



THERMOSTAT

REMOVAL

Drain the coolant (page 7-7).

Remove the bolts and thermostat housing protector.

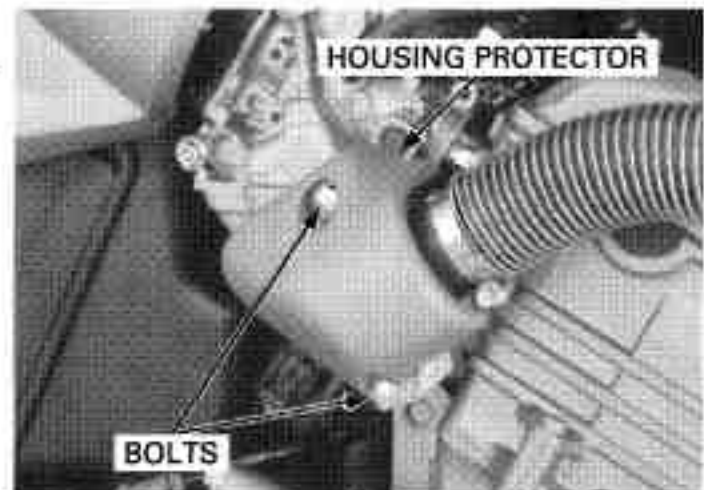

Remove the bolts, protector bracket and thermostat housing cover.

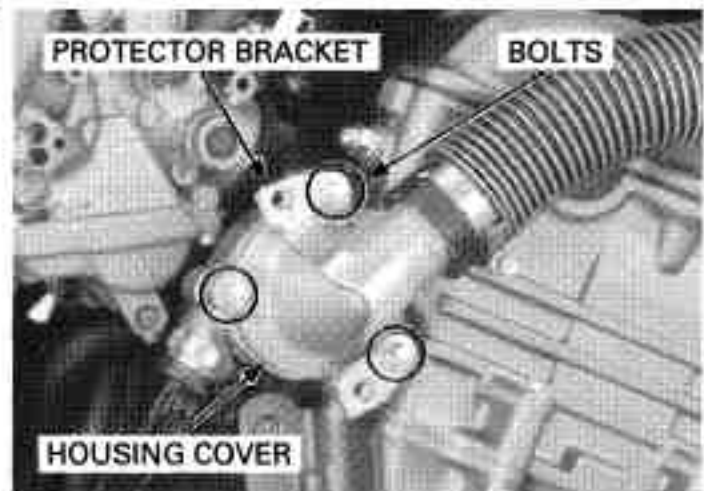

Remove the O-ring from the thermostat housing cover.

Remove the thermostat from the housing.

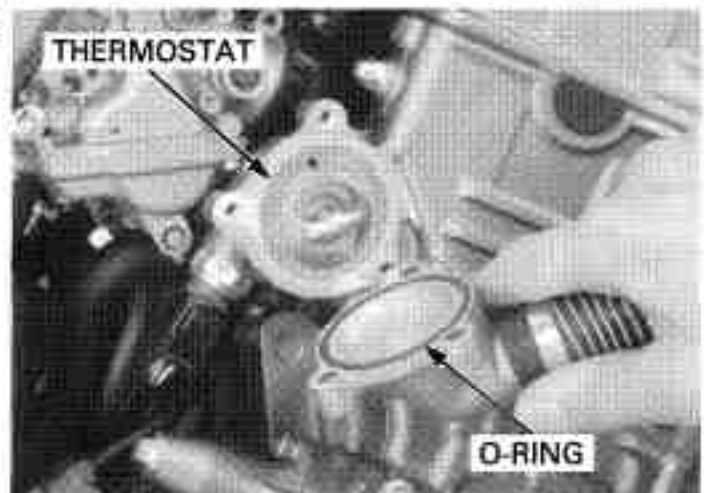

INSPECTION

Wear insulated gloves and adequate eye protection. Keep flammable materials away from the electric heating element.

Visually inspect the thermostat for damage.

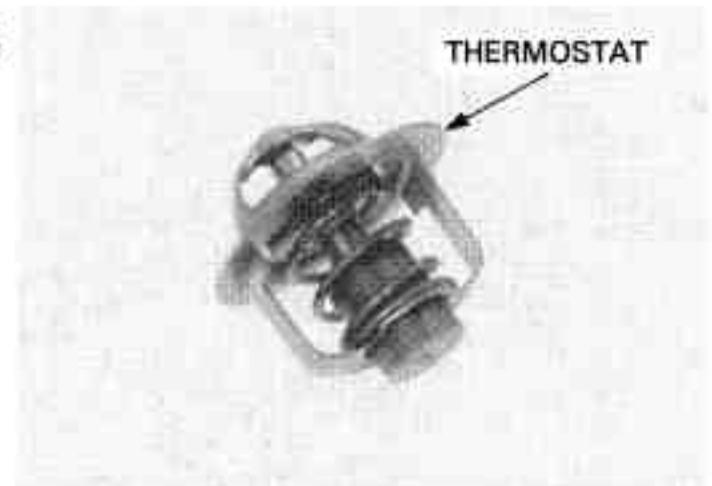

Do not let the thermostat or thermometer touch the pan, or you will get false reading.

Heat the water with an electric heating element to operating temperature for 5 minutes. Suspend the thermostat in heated water to check its operation.

Replace the thermostat if the valve stays open at room temperature, or if it responds at temperatures other than those specified.

THERMOSTAT BEGIN TO OPEN:

80 – 84 °C (176 – 183 °F)

VALVE LIFT:

8 mm (0.3 in) minimum at 95 °C (203 °F)

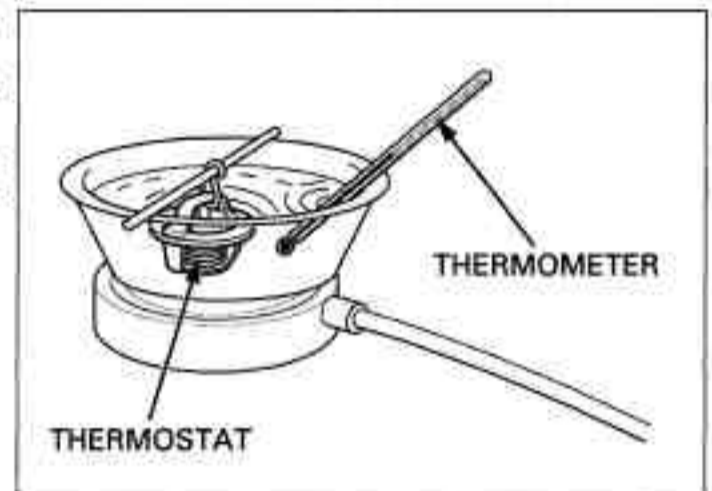

INSTALLATION

Install the thermostat into the housing by aligning the body with the groove of the housing.

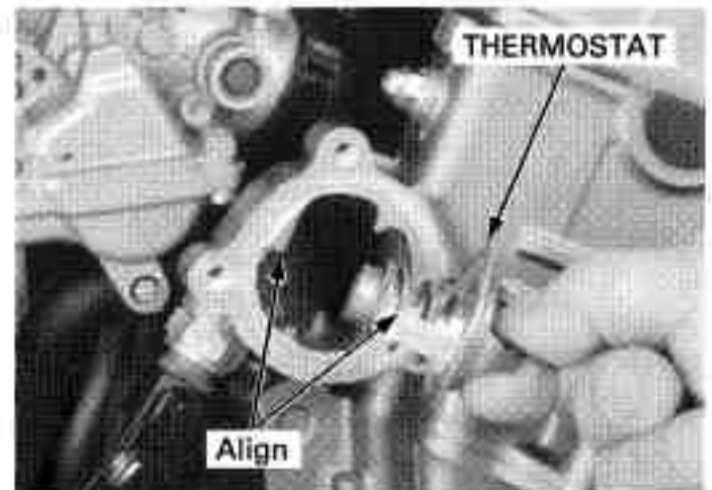

Make sure the thermostat air bleed hole facing up. Install a new O-ring to the thermostat housing cover groove.

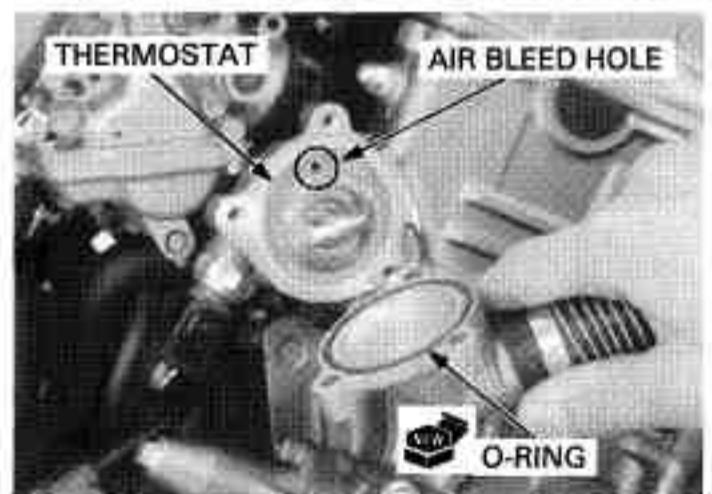

COOLING SYSTEM

Install the thermostat housing cover onto the housing.
Install the thermostat housing protector bracket.
Install and tighten the bolts securely.

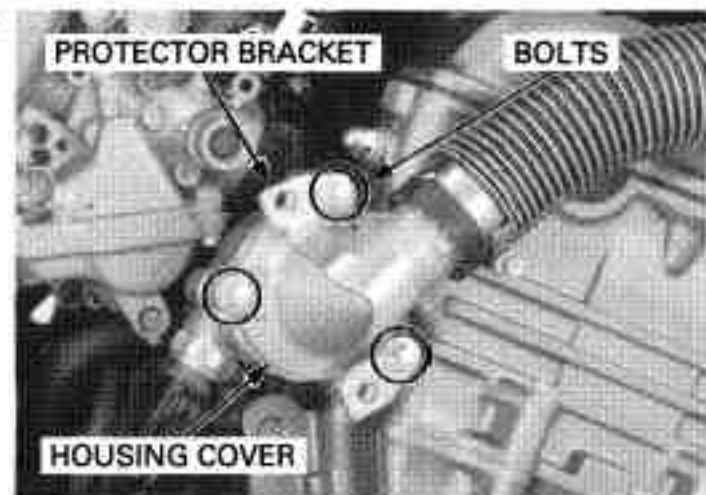

Install the thermostat housing protector and tighten the bolts securely.

Fill the system with recommended coolant and bleed the air (page 7-7).

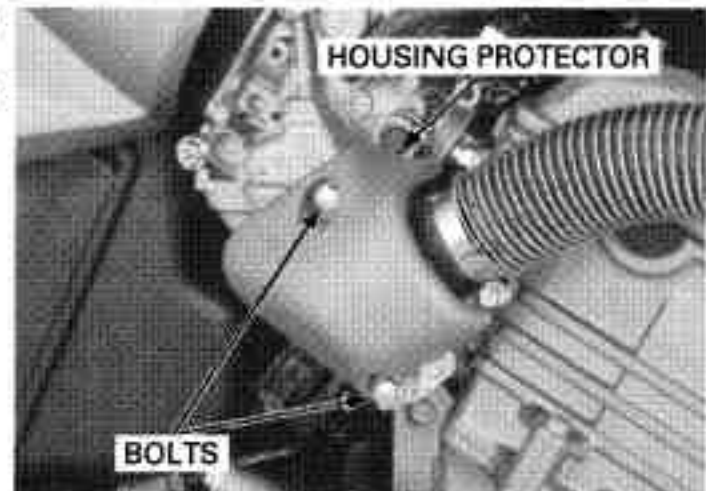

RADIATOR

REMOVAL

Remove the fuel tank (page 3-6).
Drain the coolant (page 7-7).

Disconnect the radiator sub-harness 3P (Black) connector.

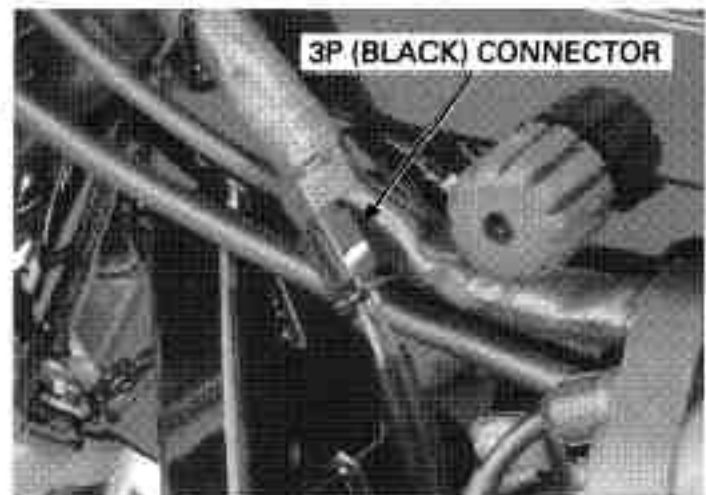

Disconnect the siphon hose.
Loosen the hose band screw and disconnect the upper radiator hose from the right side of the radiator.

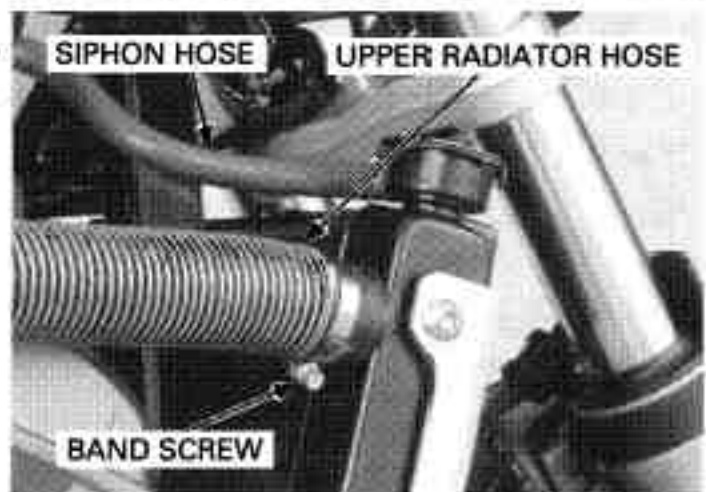

Loosen the hose band screw and disconnect the lower radiator hose from the left side of the radiator.

After '04 model only:

Disconnect the fan motor switch connector.

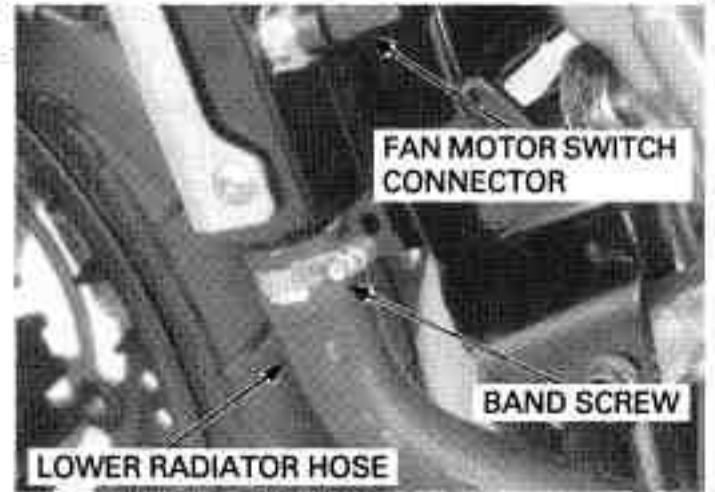

Remove the radiator mounting bolts and collars.

Slide the radiator to the right, then release the grommet from the frame boss.

Be careful not to damage the radiator core.

Remove the radiator assembly.

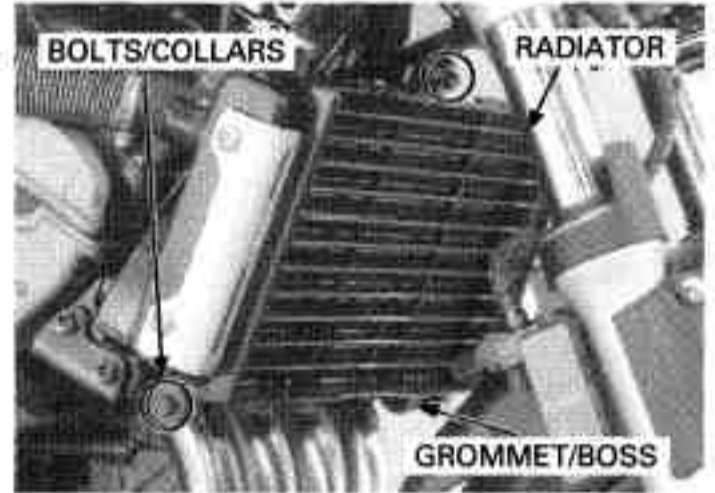

DISASSEMBLY

Release the hooks from the tabs on the radiator and remove the radiator grill.

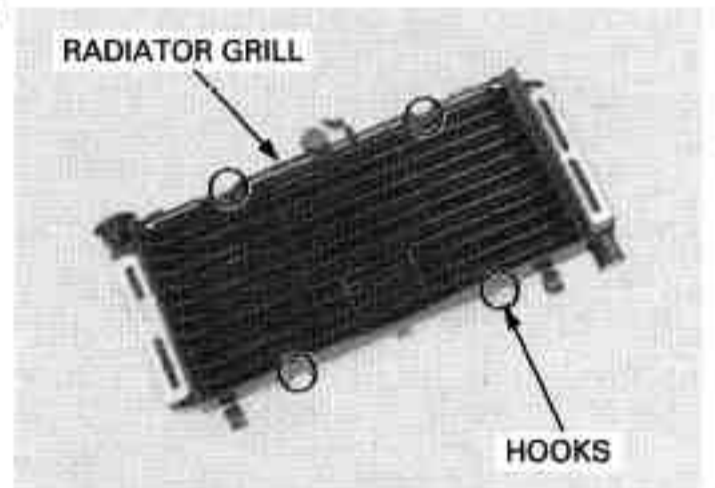

Remove the bolts and radiator grill side covers.

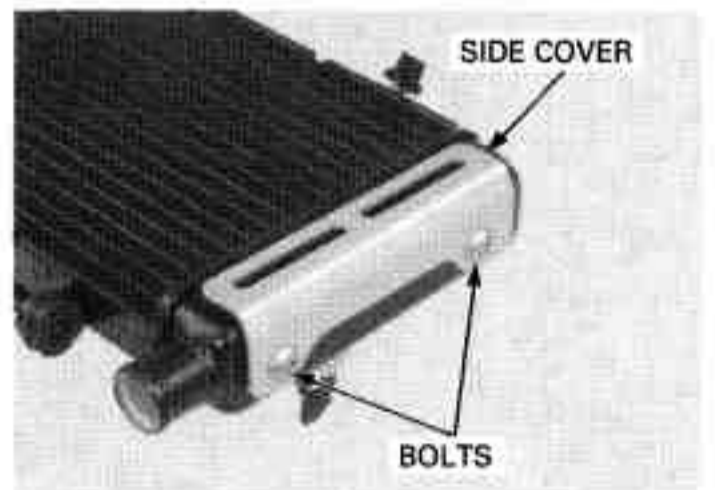

COOLING SYSTEM

'04 model only: Disconnect the fan motor switch connector and release the sub-harness from the clamp.

Remove the bolts, ground eyelet and cooling fan motor assembly.

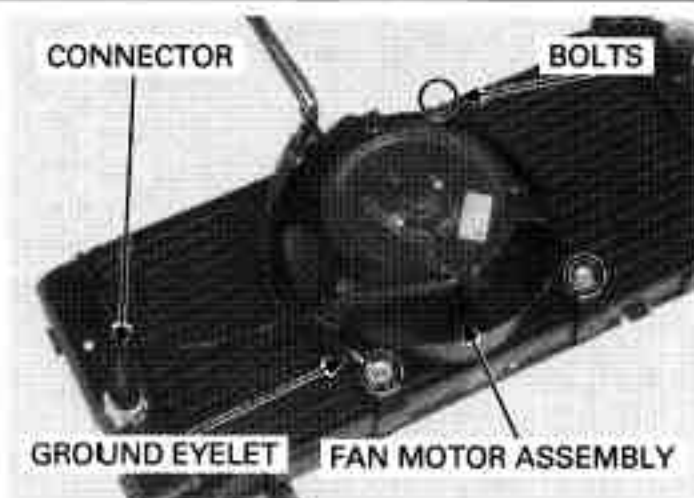

Remove the nut and cooling fan.

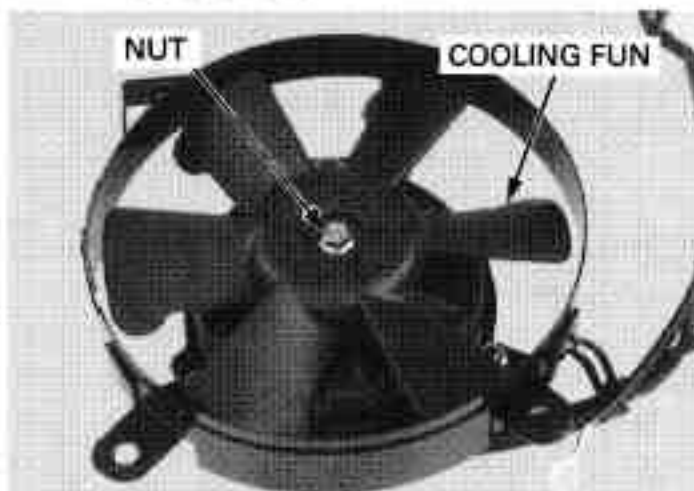

Remove the nuts and fan motor from the fan motor shroud.

Refer to the fan motor switch information.

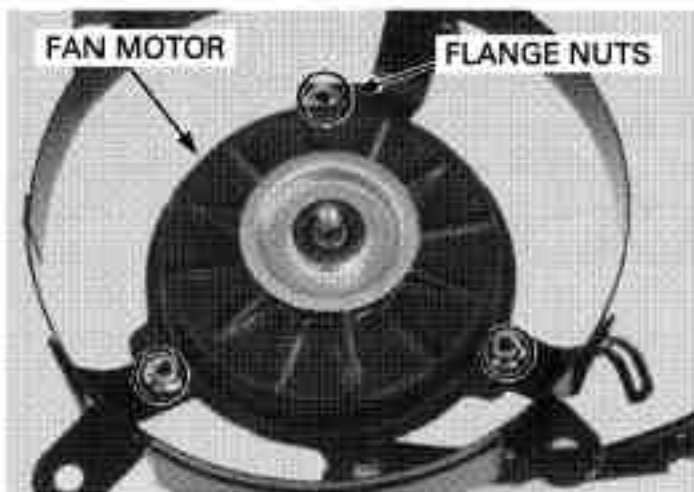

ASSEMBLY

'04 model:

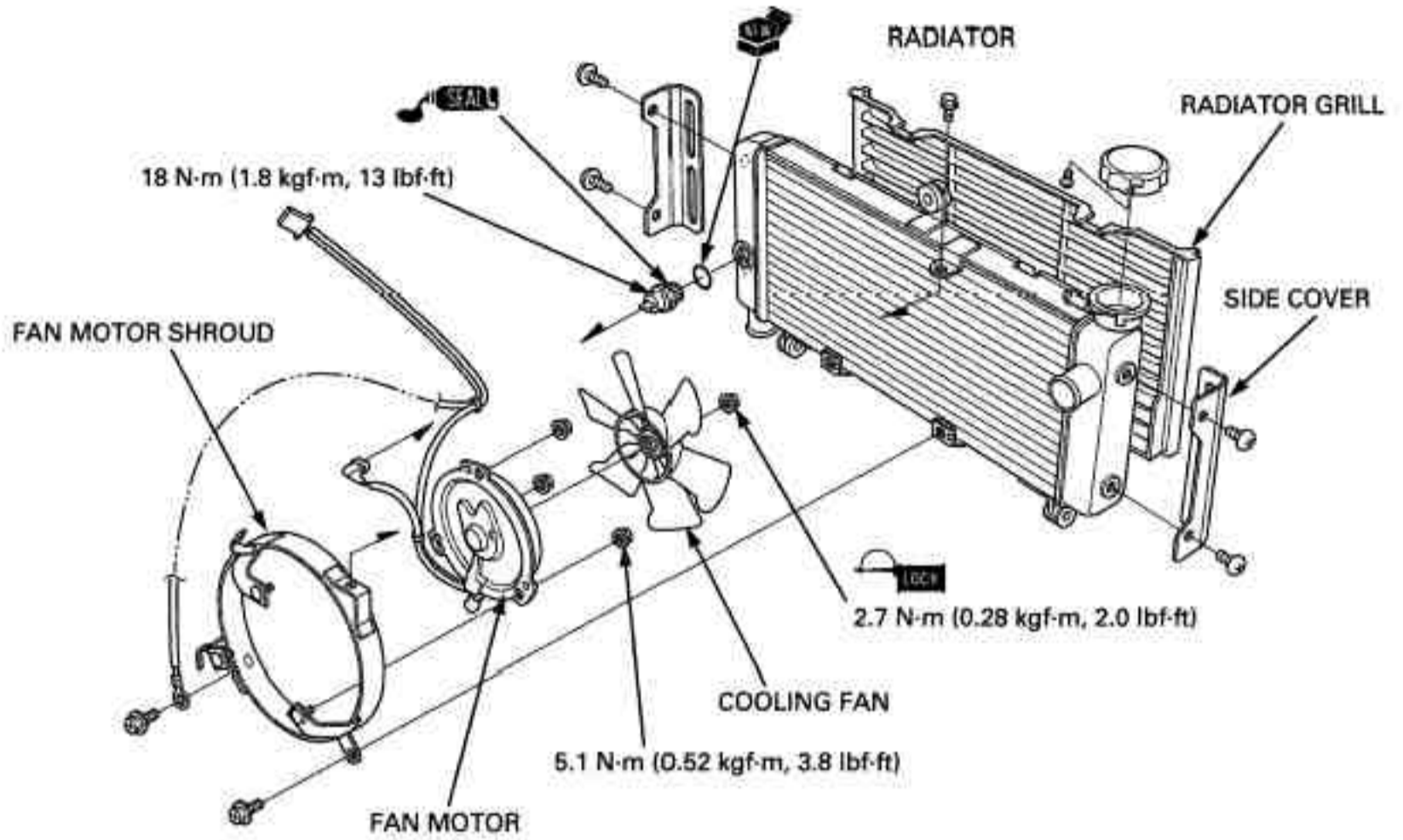

After '04 model:

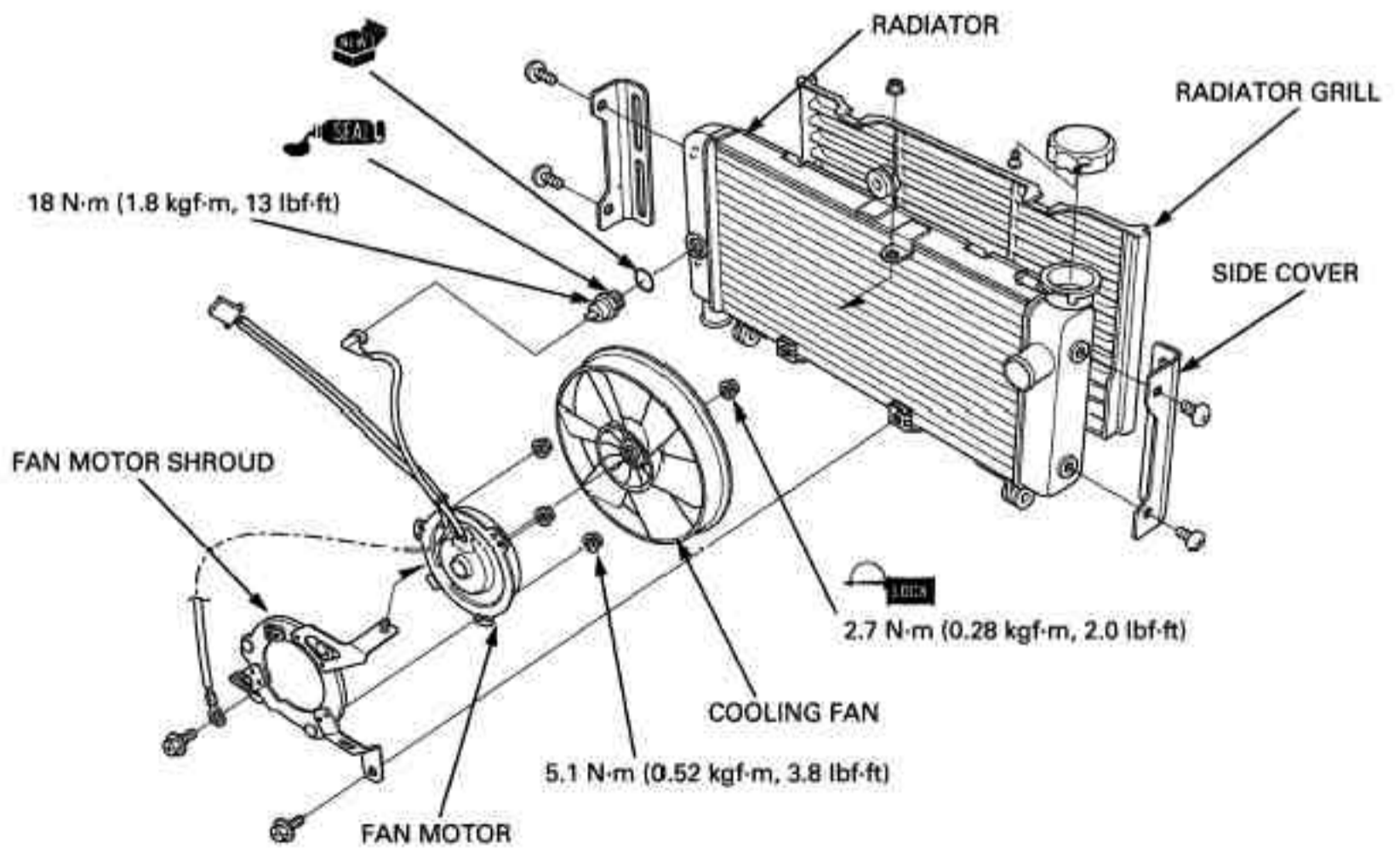

COOLING SYSTEM

Install the fan motor onto the fan motor shroud and tighten the nuts to the specified torque.

TORQUE: 5.1 N·m (0.52 kgf·m, 3.8 lbf·ft)

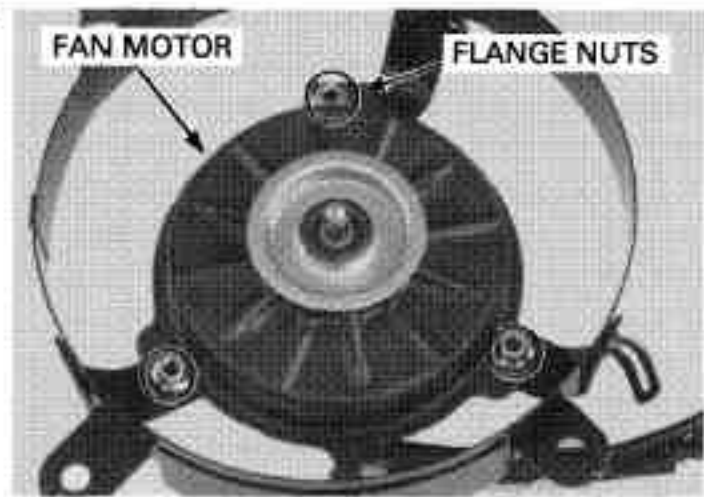

Install the cooling fan onto the fan motor shaft by aligning the flat surfaces.

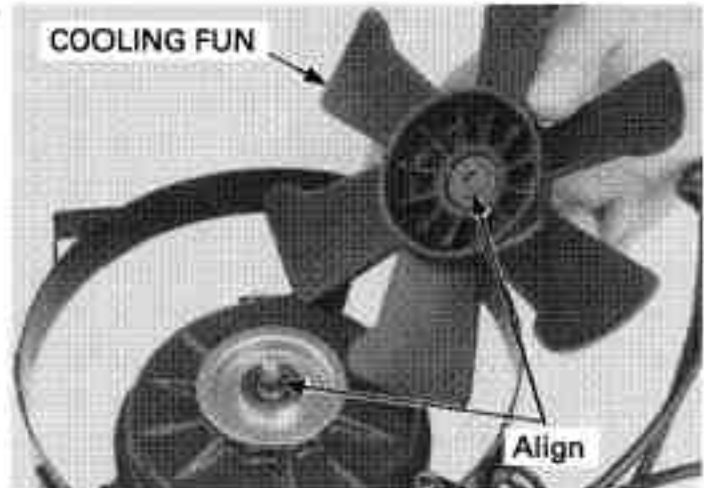

Apply a locking agent to the cooling fan nut threads. Install and tighten the nut to the specified torque.

TORQUE: 2.7 N·m (0.28 kgf·m, 2.0 lbf·ft)

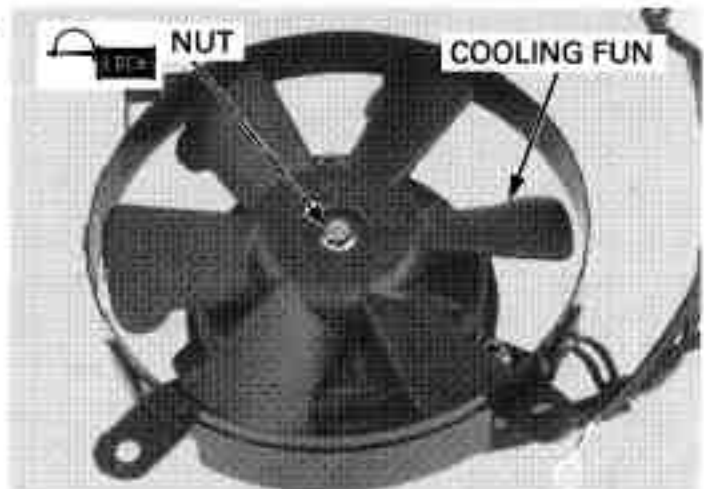

Install the cooling fan motor assembly onto the radiator.
Route the ground eyelet properly.
Install and tighten the bolts securely.

'04 model only: Install the radiator sub-harness connector to the fan motor bracket.
Connect the fan motor switch connector.

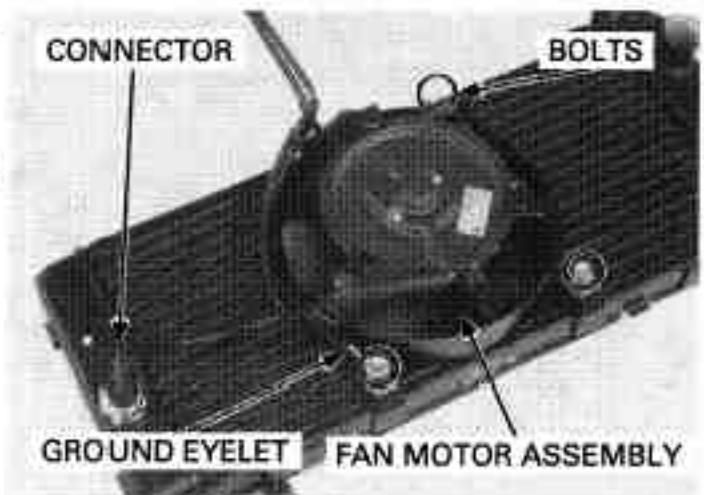

Install the radiator grill side covers.
Install and tighten the bolts securely.

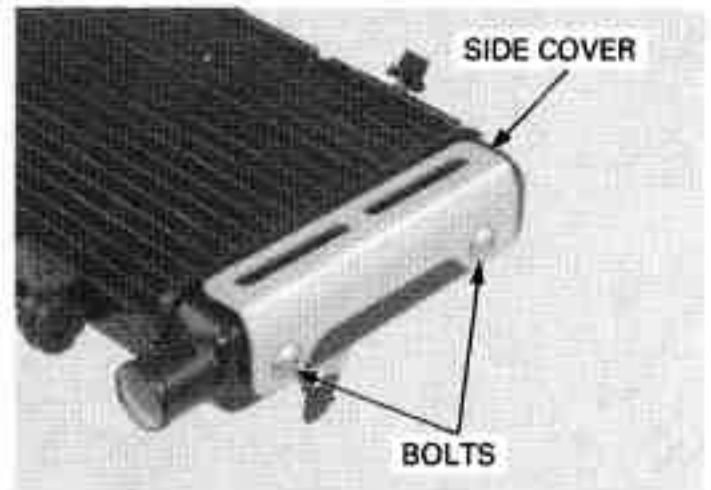

Install the radiator grill while aligning the tabs to hooks on the radiator.

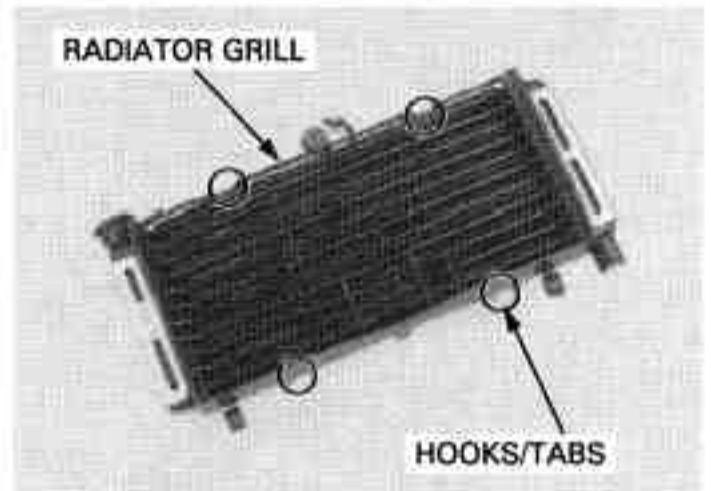

INSTALLATION

Be careful not to damage the radiator core.

Install the radiator assembly, aligning its grommet with the frame boss.

Install the collars and bolts, then tighten the bolts securely.

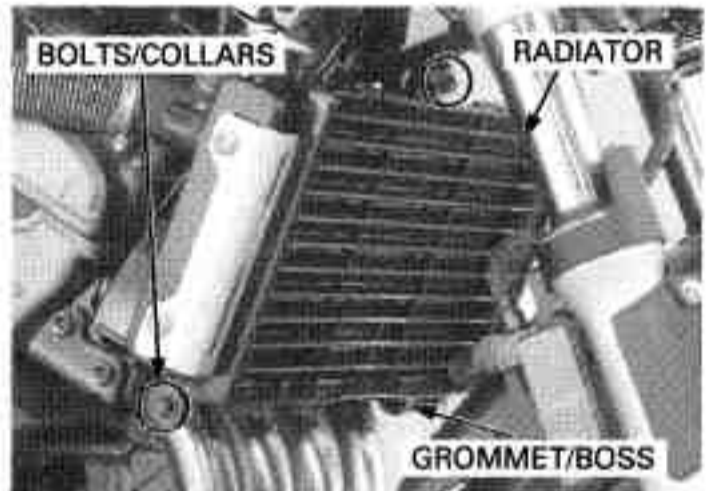

Connect the lower radiator hose and tighten the hose band screw securely.

After '04 model only:

Connect the fan motor switch connector.

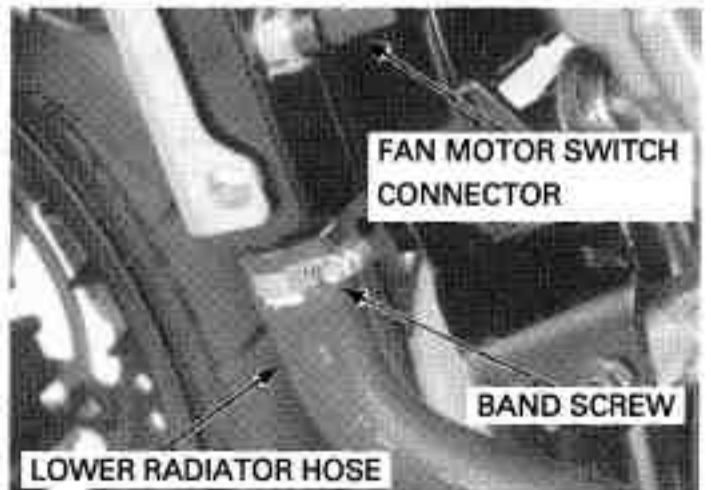

COOLING SYSTEM

Connect the upper radiator hose and tighten the hose band screw securely.

Connect the siphon hose to the radiator securely.



Connect the radiator sub-harness 3P (Black) connector.

Fill the system with recommended coolant (page 7-6).

Install the fuel tank (page 3-6).

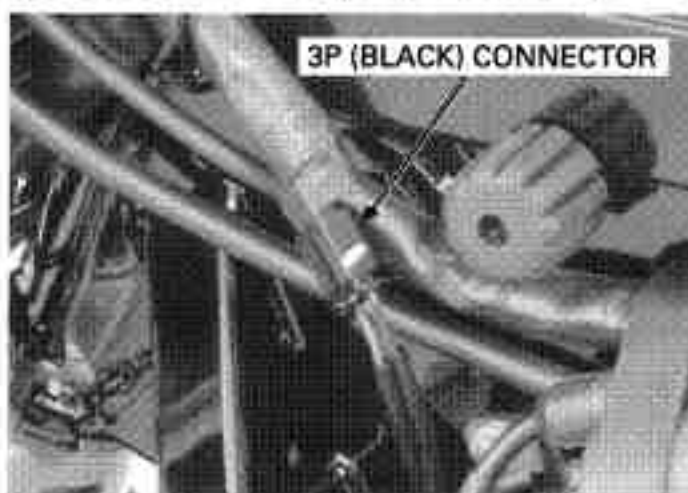

RADIATOR RESERVE TANK

REMOVAL/INSTALLATION

Remove the rear fender (page 3-8).

Remove the fuse box.

Disconnect the siphon hose.

Remove the bolt and radiator reserve tank.

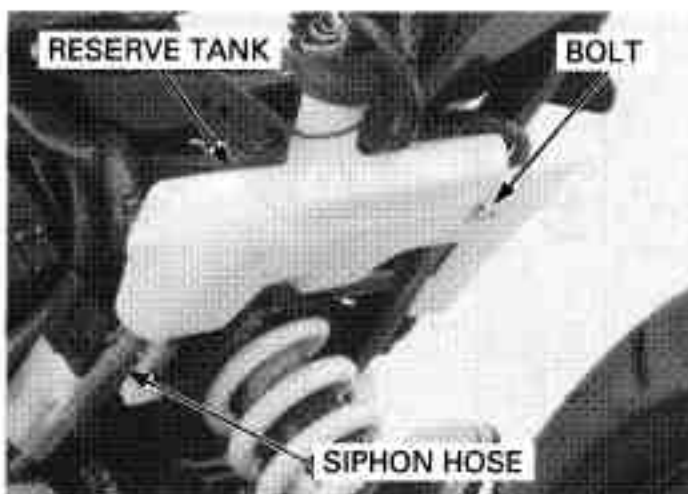

Installation is in the reverse order of removal.

Fill the system with recommended coolant (page 7-6).

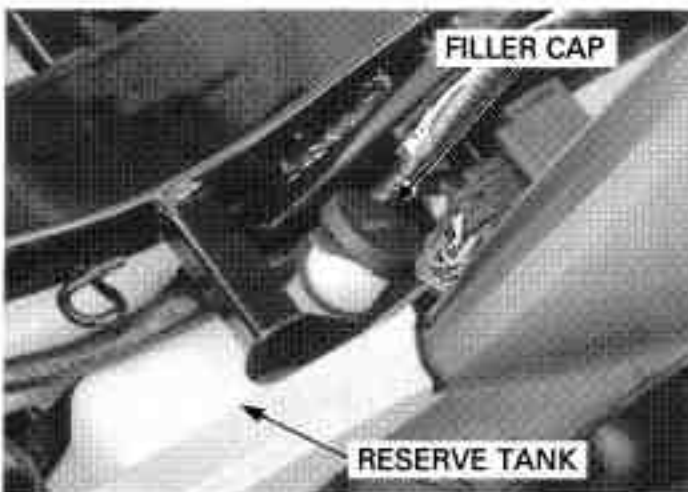

WATER PUMP

MECHANICAL SEAL INSPECTION

Inspect the inspection hole for signs of coolant leakage.

If there is leakage, the mechanical seal is defective and replace the water pump as an assembly.

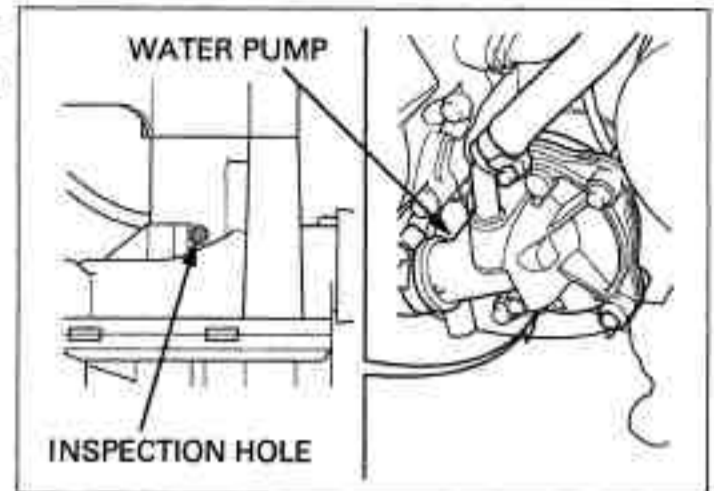

REMOVAL

Drain the coolant (page 7-7).

Loosen the hose band screws.

Disconnect the lower radiator hose and bypass hose from the water pump cover.

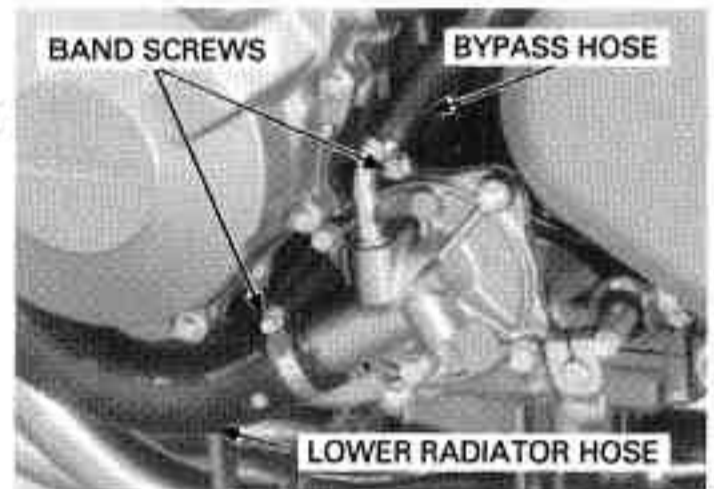

Remove the two SH bolts, two flange bolts and water pump cover.

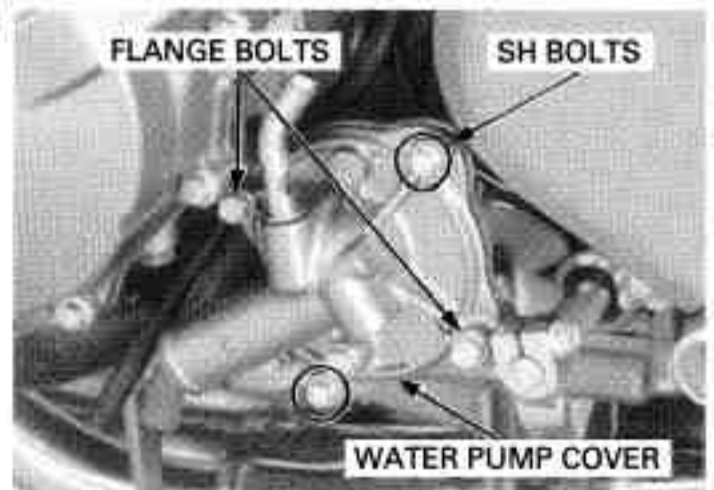

Remove the O-ring from the water pump body.

Loosen the hose band screw and disconnect the oil cooler water hose from the water pump body.

Remove the water pump body from the crankcase.

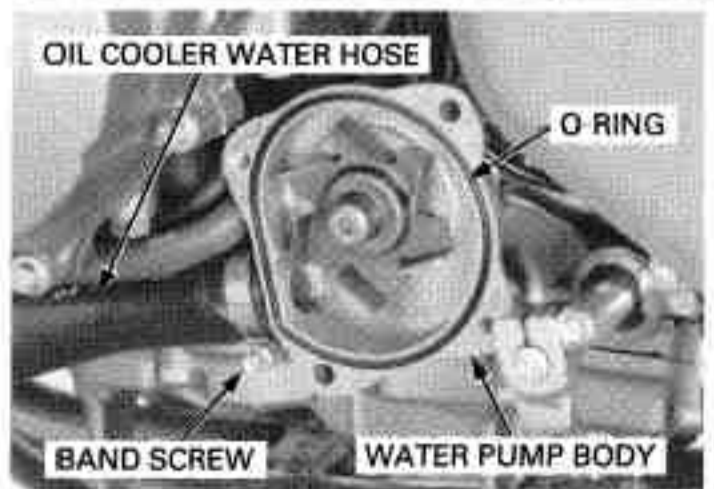

COOLING SYSTEM

INSTALLATION

Apply engine oil to a new O-ring and install it onto the stepped portion of the water pump body.

Install the water pump into the crankcase while aligning the water pump shaft groove with the oil pump shaft end by turning the water pump impeller.

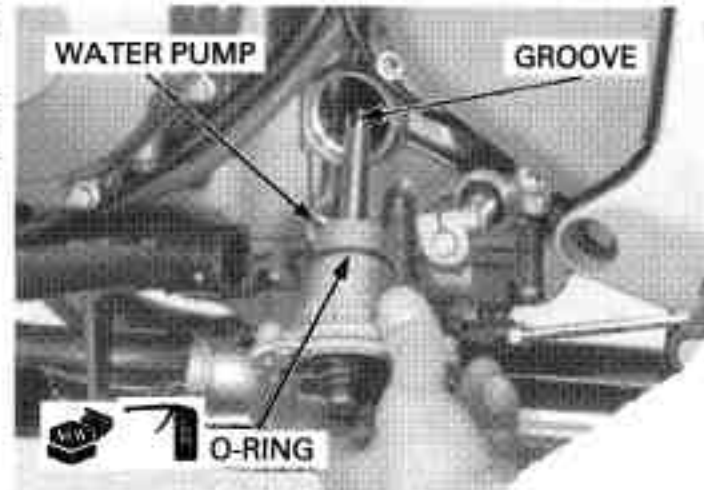

Connect the oil cooler water hose to the water pump and tighten the band screws securely.

Align the mounting bolt holes in the water pump and crankcase and make sure the water pump is securely installed.

Apply grease to a new O-ring and install it into the groove in the water pump body.

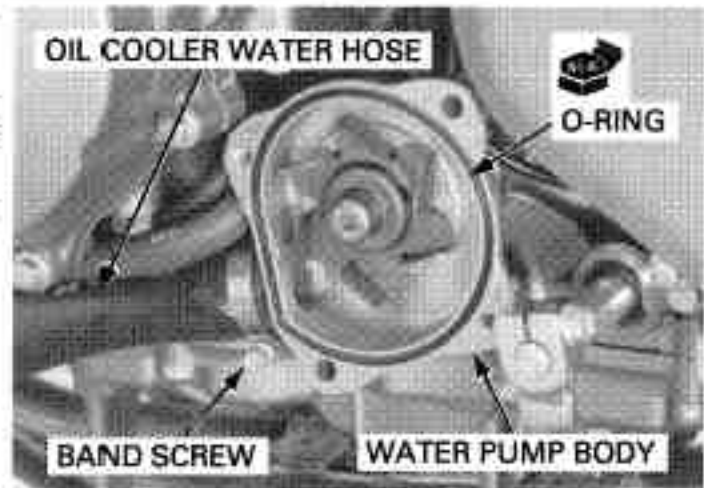

Install the water pump cover, two SH bolts and two flange bolts.

Tighten the flange bolts to the specified torque.

TORQUE: 13 N·m (1.3 kgf·m, 9 lbf·ft)

Tighten the two SH bolts securely.

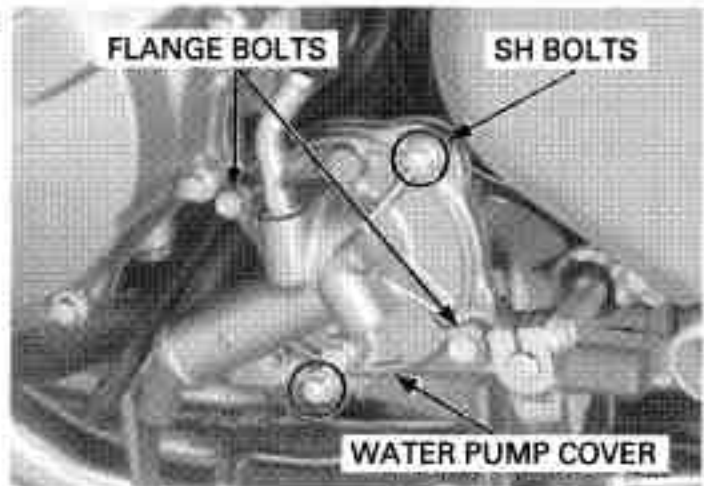

Connect the lower radiator hose and bypass hose, then tighten the band screws securely.

Fill the system with recommended coolant and bleed the air (page 7-7).

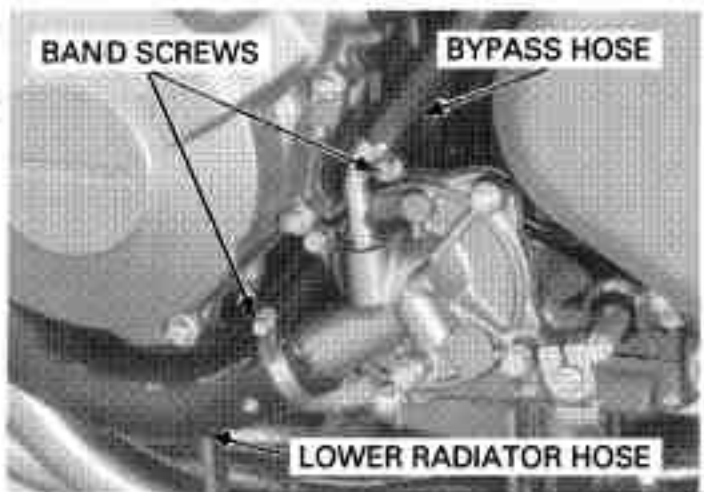

8. ENGINE REMOVAL/INSTALLATION

COMPONENT LOCATION	8-2	ENGINE REMOVAL	8-4
SERVICE INFORMATION	8-3	ENGINE INSTALLATION	8-7

ENGINE REMOVAL/INSTALLATION

COMPONENT LOCATION

'04 model shown:

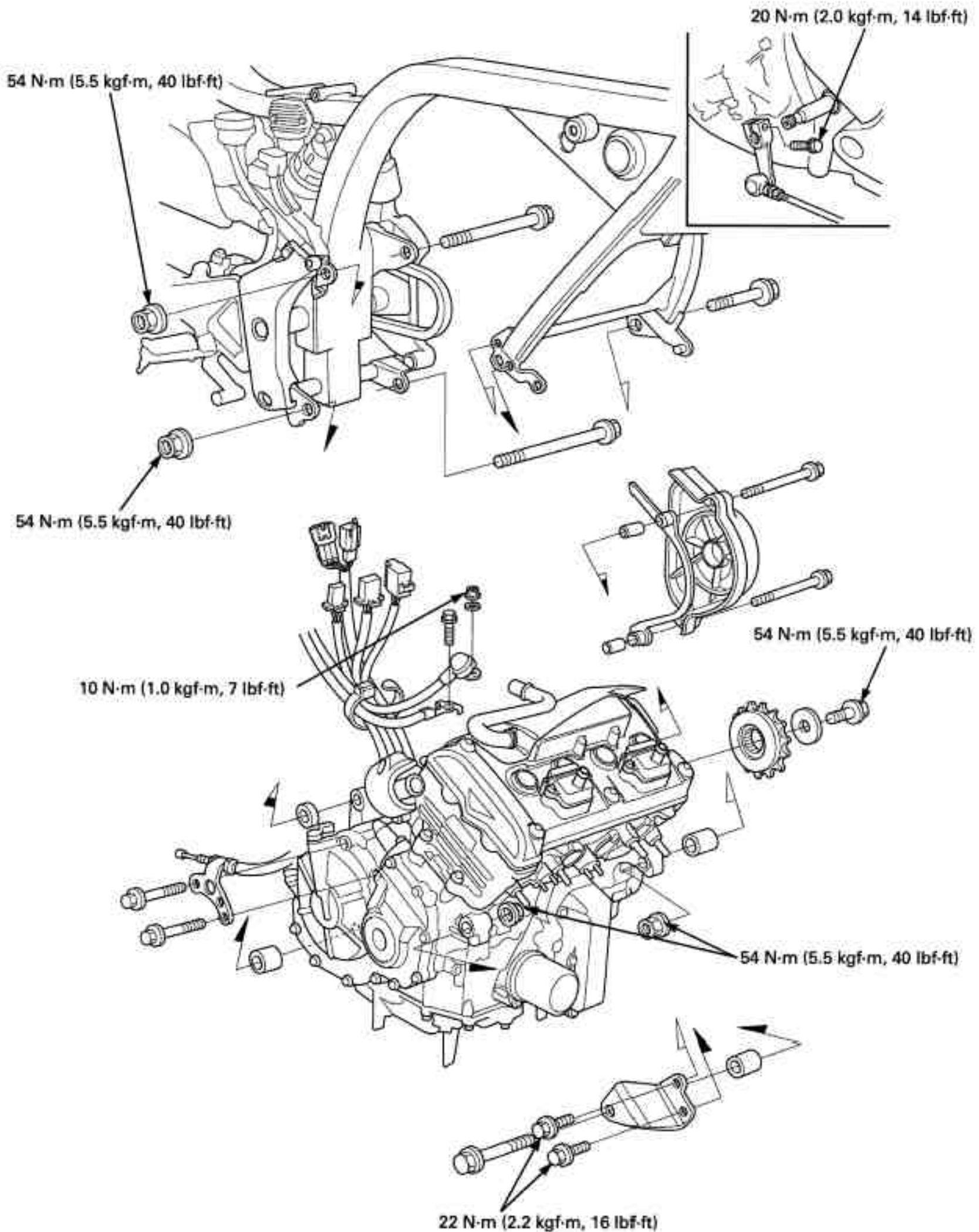

SERVICE INFORMATION

GENERAL

- A hoist or equivalent is required to support the motorcycle when removing and installing the engine.
- A floor jack or other adjustable support is required to support and maneuver the engine.

NOTICE

Do not use the oil filter as a jacking point, the engine will be damaged.

- The following components can be serviced with the engine installed in the frame.
 - Oil cooler/oil pump
 - Water pump
 - Cylinder head/valves
 - Clutch/gearshift linkage
 - Alternator/starter clutch
- The following components require engine removal for service.
 - Crankshaft/transmission
 - Piston/cylinder

SERVICE DATA

ITEM		SPECIFICATIONS
Engine dry weight		63.2 kg (139.3 lbs)
Engine oil capacity	After disassembly	4.2 liter (4.4 US qt, 3.7 Imp qt)
Coolant capacity	Radiator and engine	2.3 liter (2.43 US qt, 2.02 Imp qt)

TORQUE VALUES

Drive sprocket special bolt	54 N·m (5.5 kgf·m, 40 lbf·ft)
Front engine hanger nut	54 N·m (5.5 kgf·m, 40 lbf·ft)
Engine hanger bracket bolt	22 N·m (2.2 kgf·m, 16 lbf·ft)
Rear engine hanger nut (upper)	54 N·m (5.5 kgf·m, 40 lbf·ft)
Rear engine hanger nut (lower)	54 N·m (5.5 kgf·m, 40 lbf·ft)
Gearshift pedal link bolt (gearshift spindle side)	20 N·m (2.0 kgf·m, 14 lbf·ft)
Swingarm pivot nut	88 N·m (9.0 kgf·m, 65 lbf·ft)
Starter motor terminal nut	10 N·m (1.0 kgf·m, 7 lbf·ft)

ENGINE REMOVAL

Remove the following:

- Side cover (page 3-4)
- Fuel tank (page 3-6)
- Exhaust pipe (page 3-9)
- Carburetor (page 6-10)
- Radiator (page 7-10)

Remove the following (California type only):

- EVAP purge control valve (page 6-39)
- EVAP canister (page 6-39)

Drain the engine oil (page 4-15).

Drain the coolant (page 7-7).

Turn the ignition switch OFF and disconnect the battery negative cable.

Remove the bolts and drive sprocket cover.

Remove the drive chain guide plate and dowel pins.

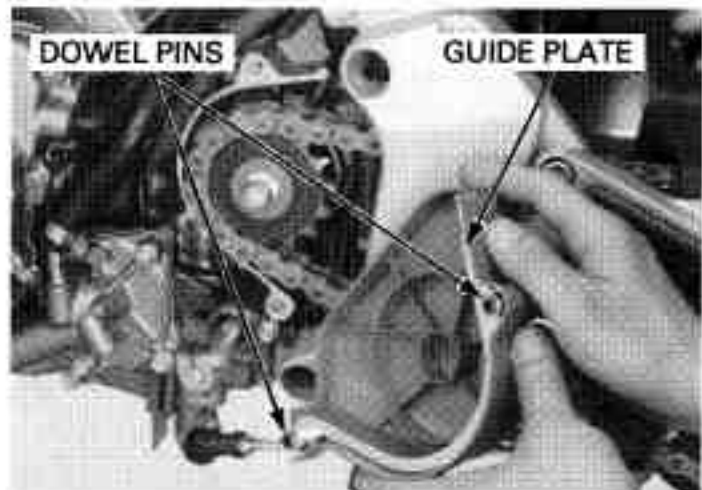
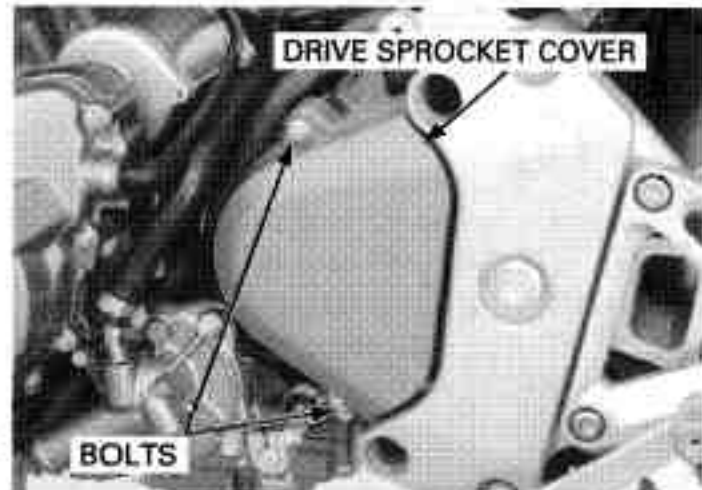

Loosen the drive sprocket special bolt while applying the rear brake with the rear wheel on the ground.

Loosen the drive chain (page 4-23).

Support the motorcycle securely using a hoist or equivalent.

Remove the drive sprocket special bolt, washer and drive sprocket.

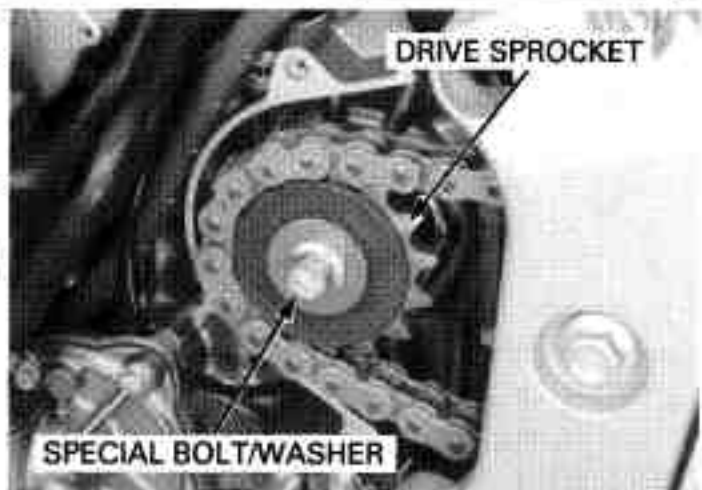

Remove the spark plug caps and ignition coil assembly (page 18-10).

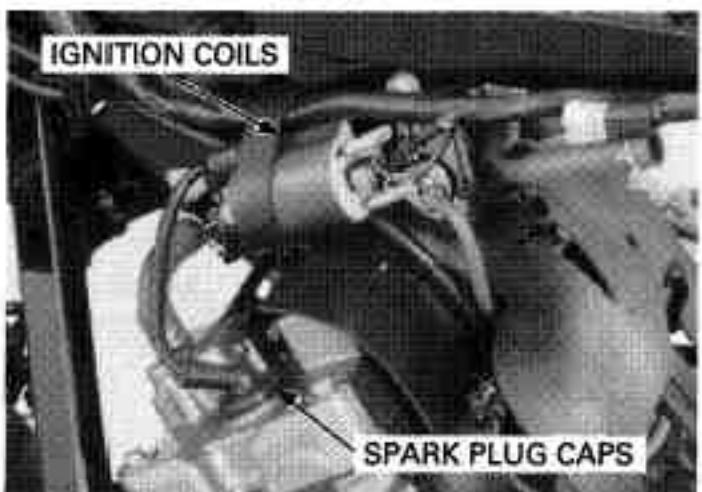

ENGINE REMOVAL/INSTALLATION

Remove the bolts and clutch cable guide, then disconnect the clutch cable from the clutch arm.

Disconnect the following connectors:

- ECT sensor 3P (Natural) connector
- Engine sub-harness 3P (Natural) connector
- Ignition pulse generator 2P (Blue) connector
- Alternator 3P (Natural) connector
- Vehicle speed sensor 3P (Natural) connector

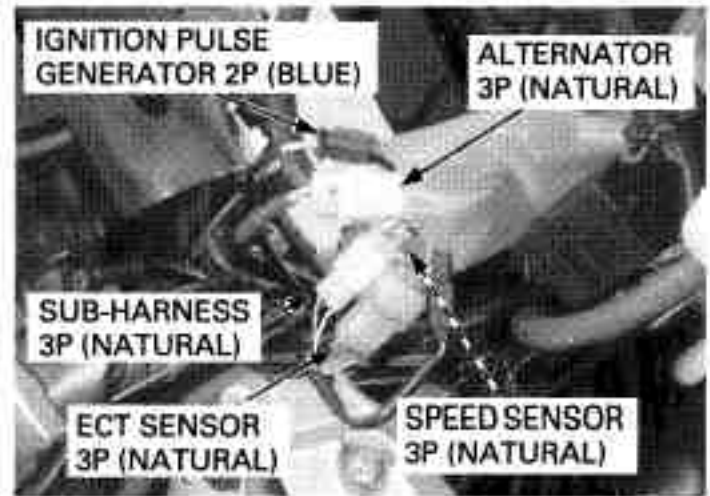

Remove the wire band.

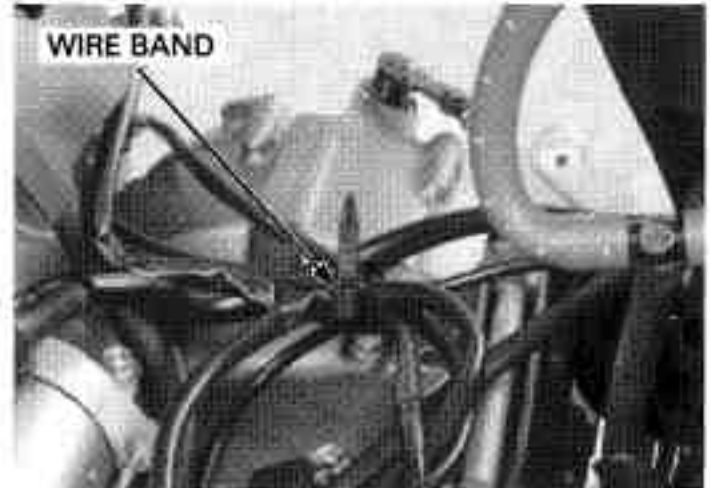

Remove the terminal nut and starter motor cable from the starter motor.
Remove the bolt and ground cable eyelet.

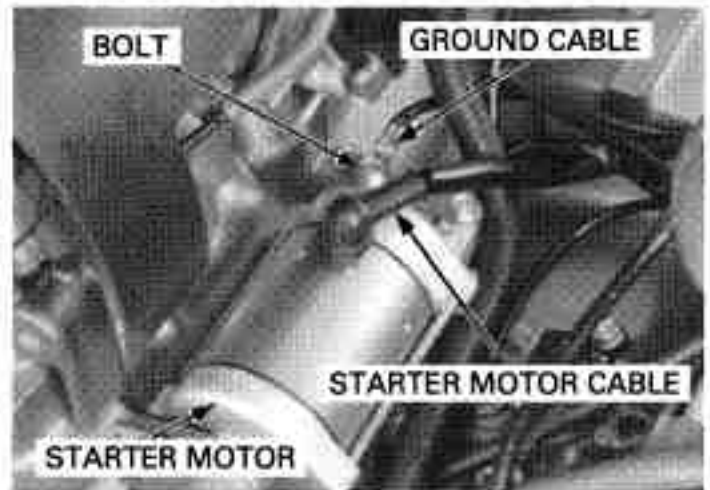

Remove the bolt and gearshift pedal link.

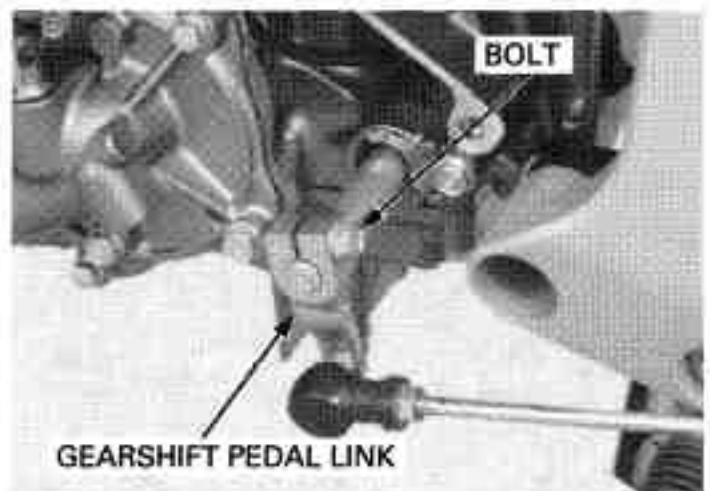

ENGINE REMOVAL/INSTALLATION

Do not use the oil filter as a jacking point, the engine will be damaged.

Place a floor jack or other adjustable support under the engine.

Remove the front right engine hanger bolt/nut and distance collar.

Remove the bolts and engine hanger bracket.

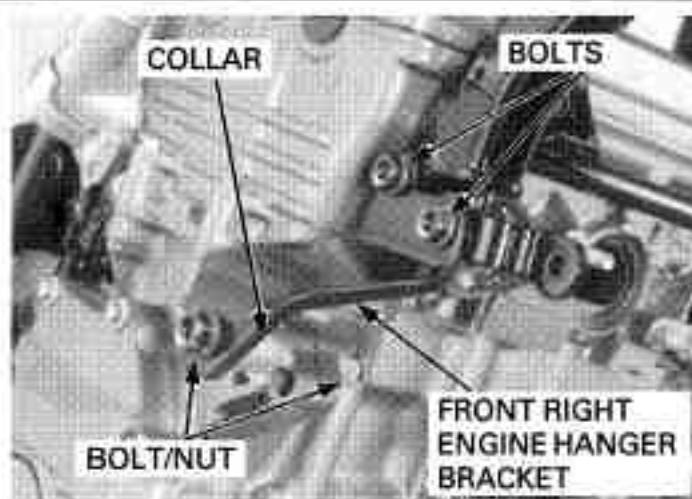

Remove the front left engine hanger bolt/nut and distance collar.

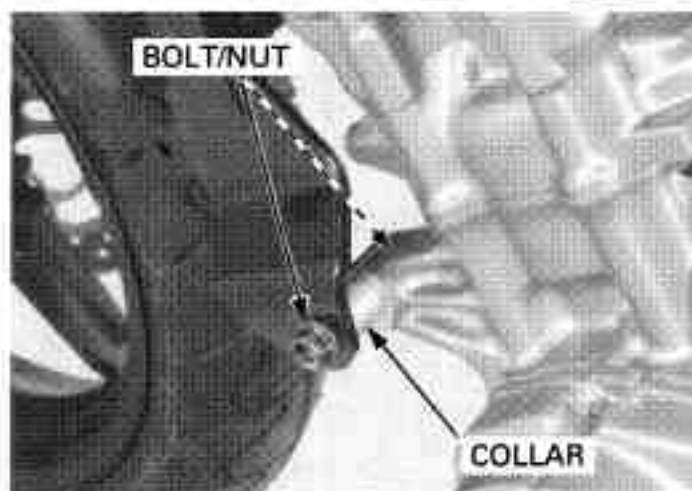

Remove the swingarm pivot nut.

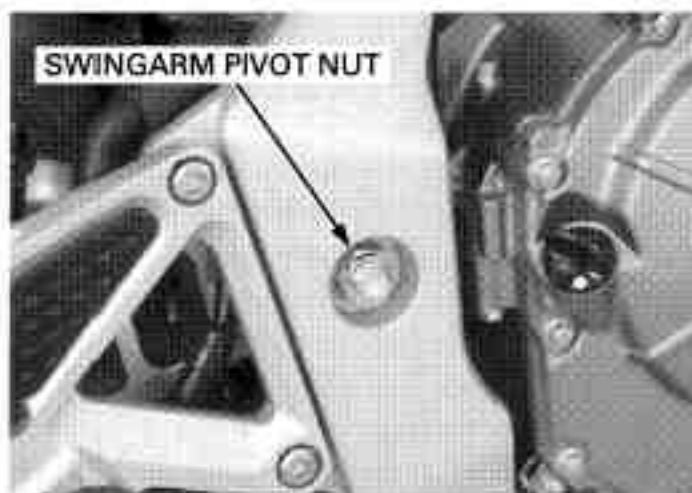

Remove the left pivot bracket mounting bolts. Slightly pull the pivot bracket outward and tilt it so that the lower engine hanger bolt can be removed.

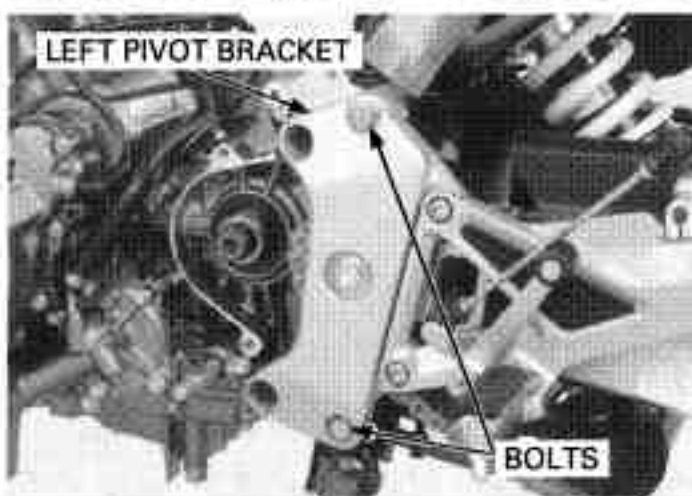

Remove the rear lower engine hanger bolt/nut and distance collar.

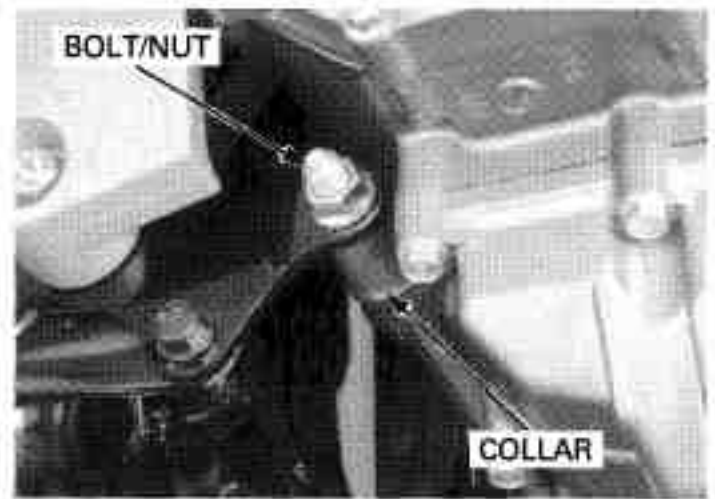

Remove the rear upper engine hanger bolt/nut and distance collar.

Carefully lower the adjustable support, then remove the engine from the frame.

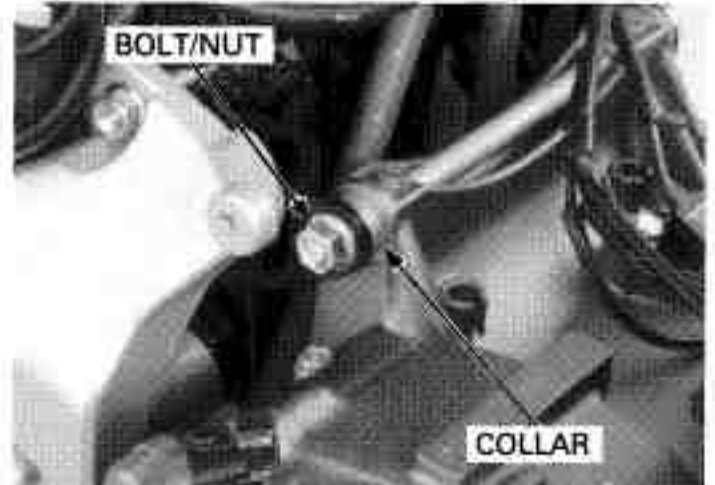

ENGINE INSTALLATION

- Note the direction of the hanger bolts.
- The jack height must be continually adjusted to relieve stress from the mounting fasteners.
- Route the wire and cables properly (page 1-23).



Install the engine into the frame.

Install the rear upper engine hanger bolt/nut and distance collar.

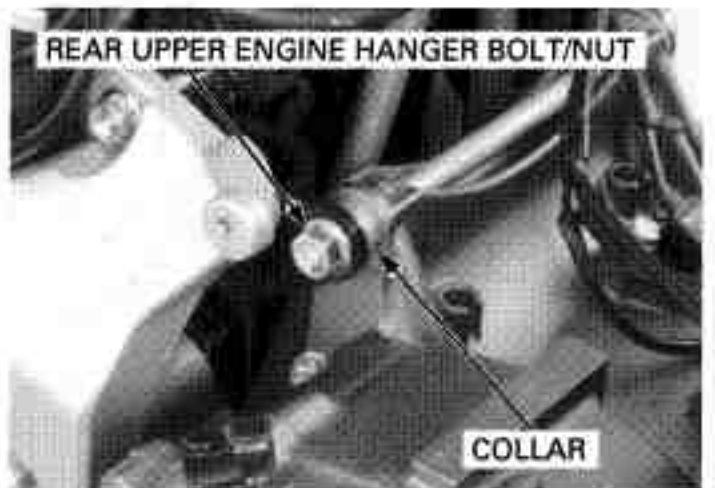

ENGINE REMOVAL/INSTALLATION

Install the rear lower engine hanger bolt/nut and distance collar.

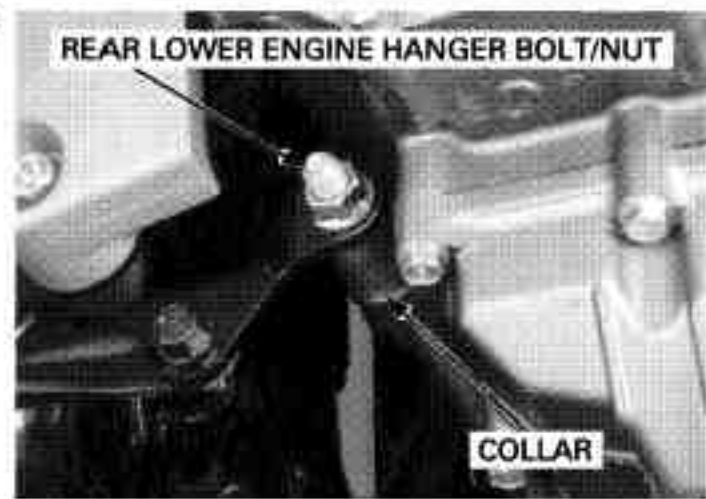

Install the left pivot bracket, then tighten the bracket bolts securely.

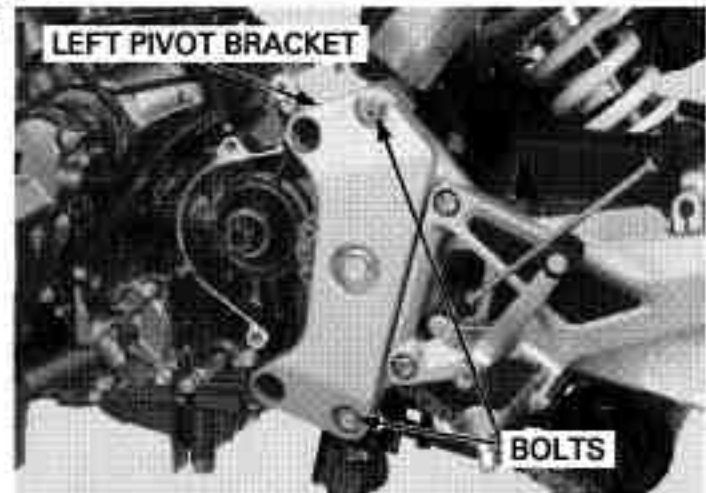

Install and tighten the swingarm pivot nut to the specified torque.

TORQUE: 88 N·m (9.0 kgf·m, 65 lbf·ft)

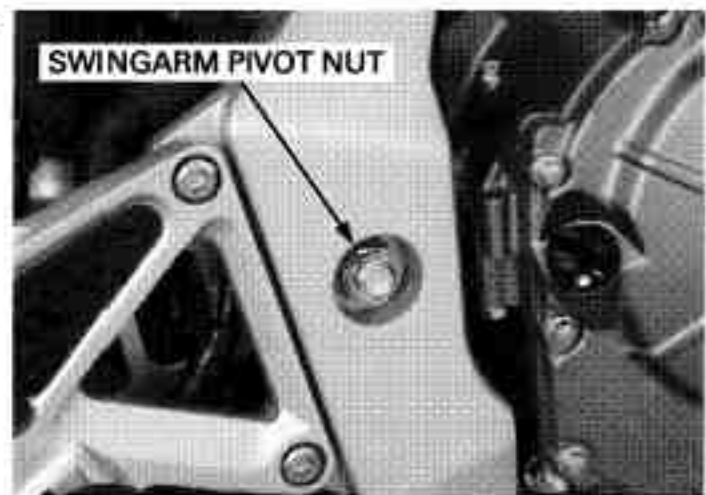

Install the front left engine hanger bolt/nut and distance collar.



ENGINE REMOVAL/INSTALLATION

Install the front right engine hanger bracket and tighten the bolts to the specified torque.

TORQUE: 22 N·m (2.2 kgf·m, 16 lbf·ft)

Install the front right engine hanger bolt/nut and distance collar.

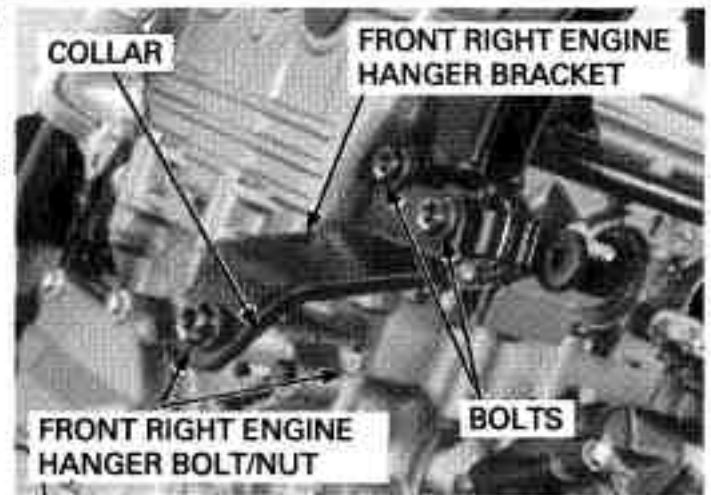

Tighten the front right engine hanger nuts to the specified torque.

TORQUE: 54 N·m (5.5 kgf·m, 40 lbf·ft)



Tighten the rear lower engine hanger nut to the specified torque.

TORQUE: 54 N·m (5.5 kgf·m, 40 lbf·ft)



Tighten the rear upper engine hanger nut to the specified torque.

TORQUE: 54 N·m (5.5 kgf·m, 40 lbf·ft)



ENGINE REMOVAL/INSTALLATION

Install the gearshift pedal link aligning its slit with the punch mark on the gearshift spindle. Install and tighten the pinch bolt to the specified torque.

TORQUE: 20 N·m (2.0 kgf·m, 14 lbf·ft)

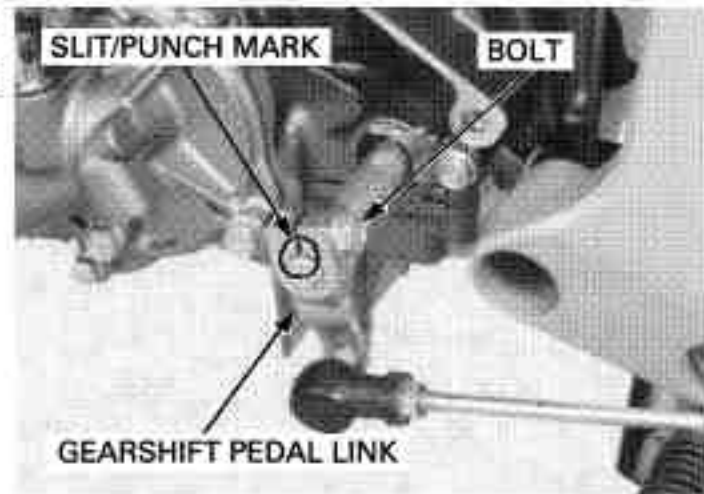

Install the ground cable eyelet and tighten the bolt securely.

Install the starter motor cable to the starter motor terminal and tighten the nut to the specified torque.

TORQUE: 10 N·m (1.0 kgf·m, 7 lbf·ft)

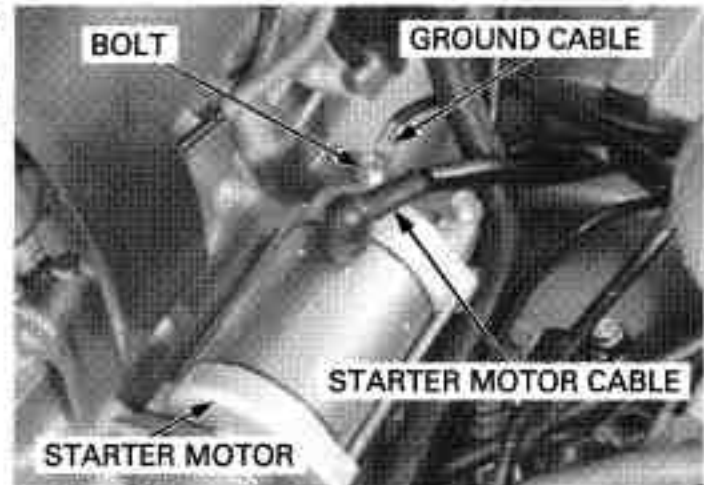

Clamp the wires using the wire band.

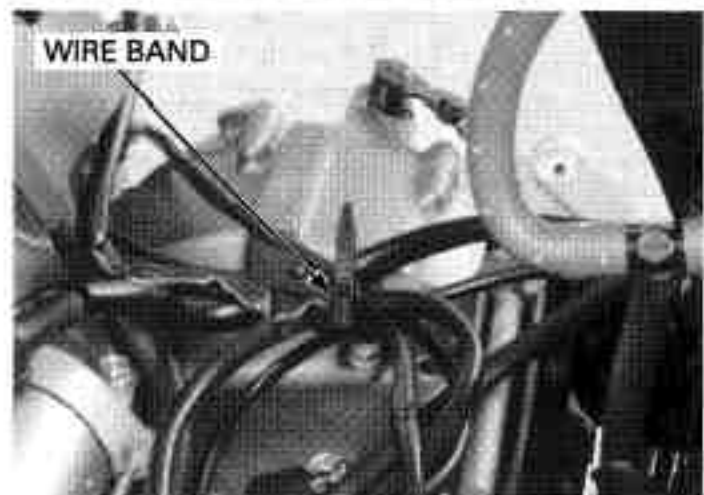

Connect the following connectors:

- ECT 3P (Natural) connector
- Engine sub-harness 3P (Natural) connector
- Ignition pulse generator 2P (Blue) connector
- Alternator 3P (Natural) connector
- Vehicle speed sensor 3P (Natural) connector

Connect the clutch cable to the clutch arm. Install the clutch cable guide and tighten the bolts securely.

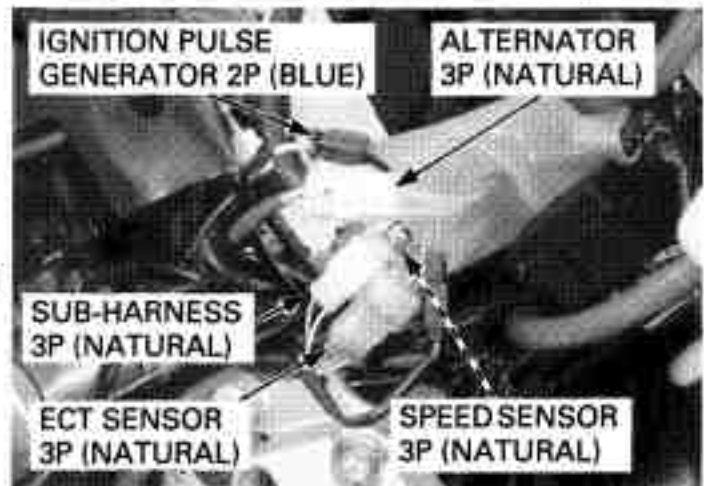

Install the ignition coil assembly (page 18-10).
Connect the spark plug caps securely (page 4-7).

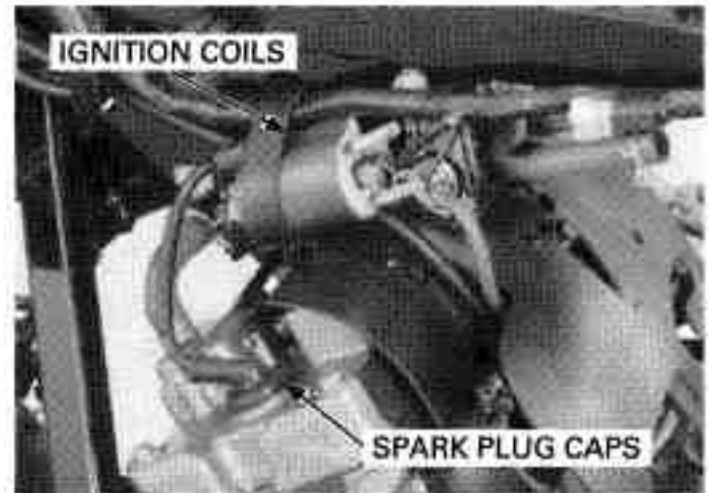

Install the drive sprocket with its "15T" mark facing outward.

Install the washer and drive sprocket special bolt.

Tighten the drive sprocket special bolt to the specified torque while applying the rear brake with the rear wheel on the ground.

TORQUE: 54 N·m (5.5 kgf·m, 40 lbf·ft)

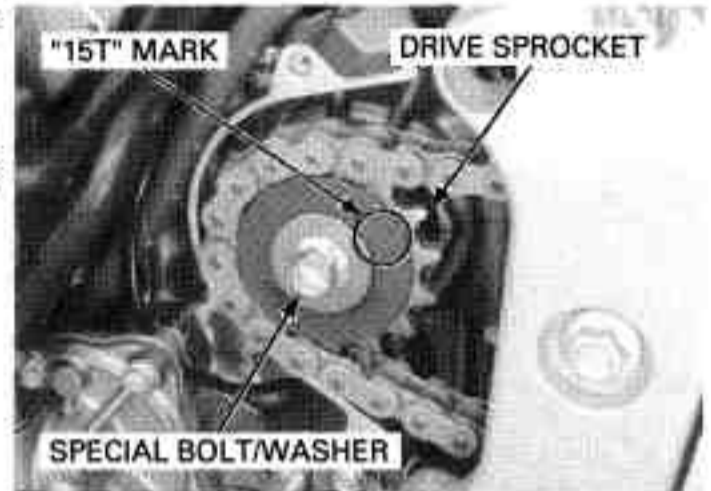

Install the dowel pins and drive chain guide plate.

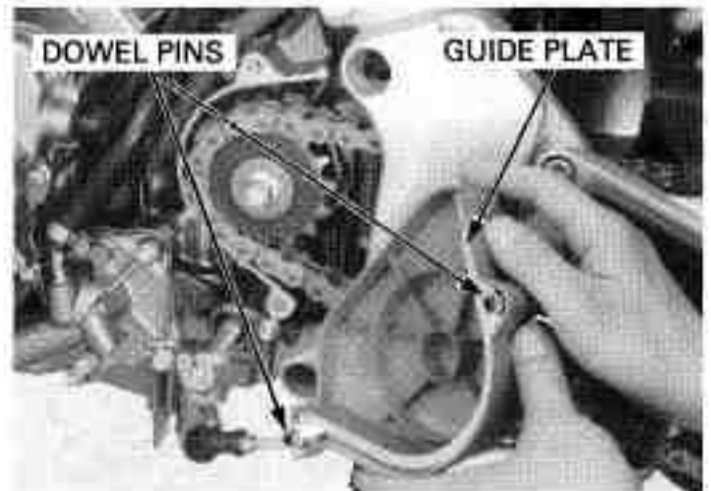

Install the drive sprocket cover and tighten the bolts securely.

Install the following:

- Side cover (page 3-4)
- Fuel tank (page 3-6)
- Exhaust pipe (page 3-9)
- Carburetor (page 6-34)
- Radiator (page 7-10)

Install the following (California type only):

- EVAP purge control valve (page 6-39)
- EVAP canister (page 6-39)

Fill the cooling system with recommended coolant and bleed the air (page 7-7).

Pour recommended engine oil up to the proper level (page 4-14).

Connect the battery negative cable.

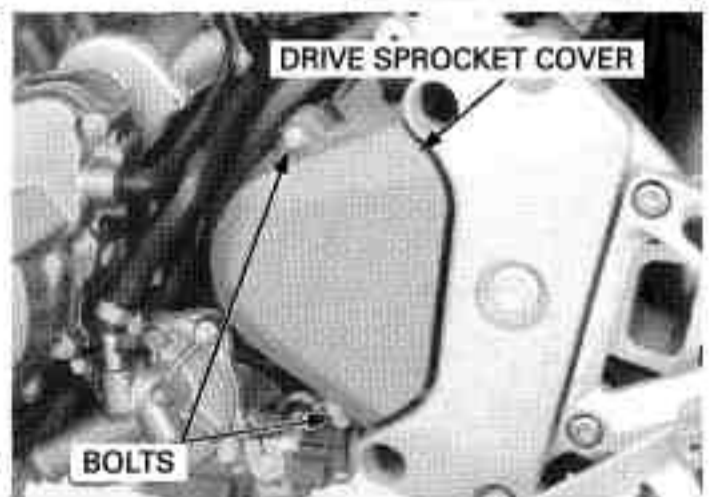

9. CYLINDER HEAD/VALVES

COMPONENT LOCATION.....	9-2	VALVE GUIDE REPLACEMENT.....	9-18
SERVICE INFORMATION.....	9-3	VALVE SEAT INSPECTION/REFACING.....	9-19
TROUBLESHOOTING.....	9-5	CYLINDER HEAD ASSEMBLY.....	9-22
CYLINDER COMPRESSION TEST.....	9-6	CYLINDER HEAD INSTALLATION.....	9-24
CYLINDER HEAD COVER REMOVAL.....	9-6	CAMSHAFT INSTALLATION.....	9-27
CYLINDER HEAD COVER DISASSEMBLY.....	9-7	CYLINDER HEAD COVER ASSEMBLY.....	9-30
CAMSHAFT REMOVAL.....	9-7	CYLINDER HEAD COVER INSTALLATION.....	9-31
CYLINDER HEAD REMOVAL.....	9-12	CAM CHAIN TENSIONER LIFTER.....	9-32
CYLINDER HEAD DISASSEMBLY.....	9-15	PAIR REED VALVE.....	9-34
CYLINDER HEAD INSPECTION.....	9-16		

CYLINDER HEAD/VALVES

COMPONENT LOCATION

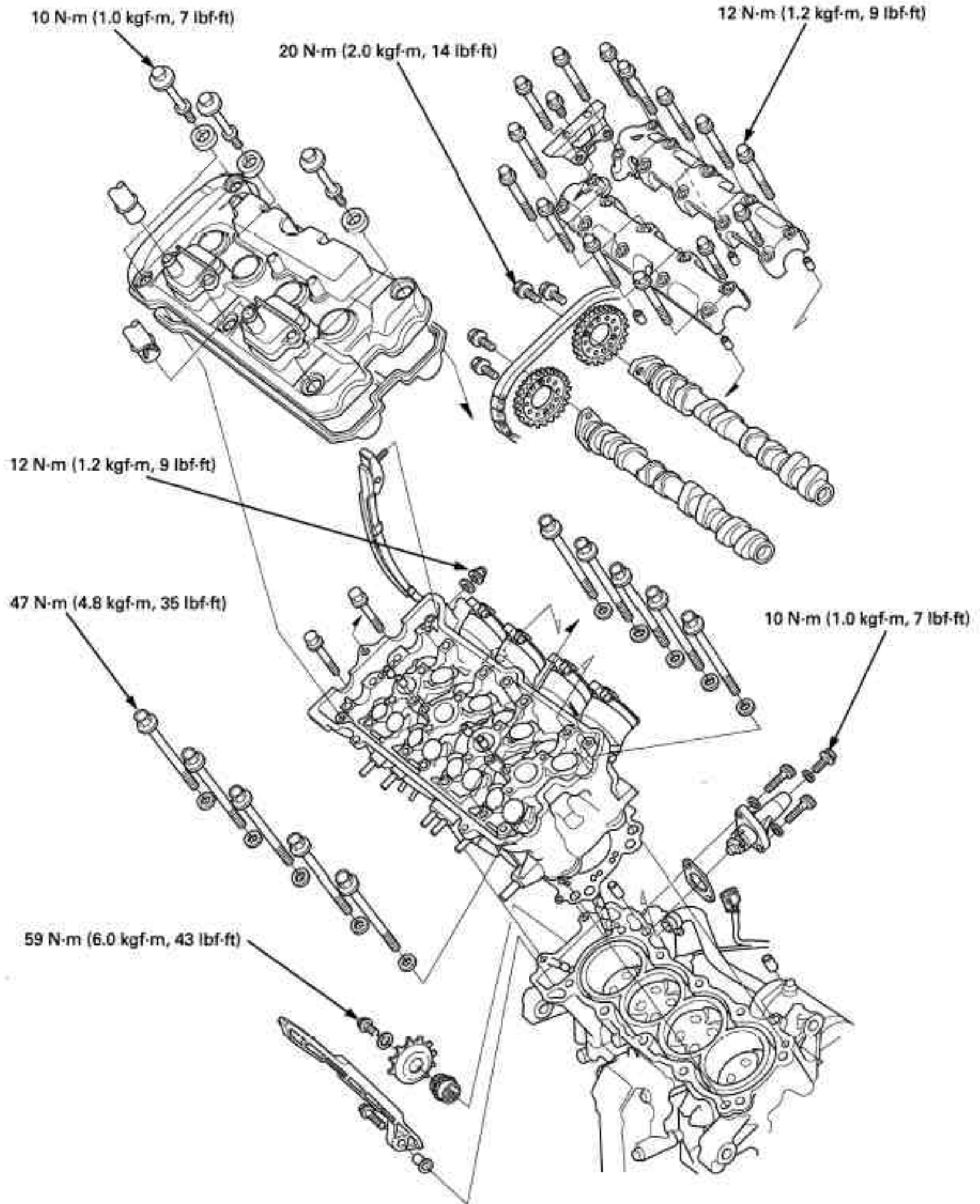

SERVICE INFORMATION

GENERAL

- This section covers service of the cylinder head, valves and camshaft.
- The camshaft services can be done with the engine installed in the frame.
- The cylinder head services can be done with the engine installed in the frame.
- When disassembling, mark and store the disassembled parts to ensure that they are reinstalled in their original locations.
- Clean all disassembled parts with cleaning solvent and dry them by blowing them off with compressed air before inspection.
- Camshaft lubricating oil is fed through oil passages in the cylinder head. Clean the oil passages before assembling cylinder head.
- Be careful not to damage the mating surfaces when removing the cylinder head cover and cylinder head.

SPECIFICATIONS

ITEM		STANDARD		SERVICE LIMIT
Cylinder compression		1,294 kPa (13.2 kgf/cm ² , 188 psi) at 350 rpm		
Valve clearance		IN	0.16 ± 0.03 (0.006 ± 0.001)	-
		EX	0.22 ± 0.03 (0.009 ± 0.001)	-
Camshaft	Cam lobe height	IN	36.220 – 36.300 (1.4260 – 1.4291)	36.03 (1.419)
		EX	35.380 – 35.460 (1.3929 – 1.3960)	35.19 (1.385)
	Journal O.D.	23.959 – 23.980 (0.9433 – 0.9411)		24.955 (0.9825)
	Runout	-		0.05 (0.002)
Oil clearance		0.020 – 0.062 (0.0008 – 0.0024)		0.10 (0.004)
Valve lifter	Valve lifter O.D.	25.978 – 25.993 (1.0228 – 1.0233)		25.97 (1.022)
	Valve lifter bore I.D.	26.010 – 26.026 (1.0240 – 1.0246)		26.04 (1.025)
Valve, valve guide	Valve stem O.D.	IN	3.975 – 3.990 (0.1565 – 0.1571)	3.965 (0.1561)
		EX	3.965 – 3.980 (0.1561 – 0.1567)	3.955 (0.1557)
	Valve guide I.D.	IN/EX	4.000 – 4.012 (0.1575 – 0.1580)	4.04 (0.159)
	Stem-to-guide clearance	IN	0.010 – 0.037 (0.0004 – 0.0015)	0.075 (0.0030)
		EX	0.020 – 0.047 (0.0008 – 0.0019)	0.085 (0.0033)
	Valve guide projection above cylinder head	IN	13.10 – 13.30 (0.516 – 0.524)	-
		EX	11.30 – 11.50 (0.445 – 0.453)	-
Valve seat width	IN/EX	0.90 – 1.10 (0.035 – 0.043)	1.5 (0.06)	
Valve spring free length		IN/EX	38.25 (1.506)	37.05 (1.46)
Cylinder head warpage		-		0.10 (0.004)









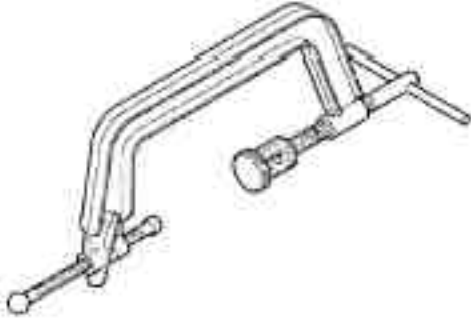

Unit: mm (in)

TORQUE VALUES

Cylinder head sealing bolt	32 N·m (3.3 kgf·m, 24 lbf·ft)	Apply a locking agent to the threads
Cylinder head bolt	47 N·m (4.8 kgf·m, 35 lbf·ft)	Apply oil to the threads and flange surface
No.1 intake vacuum port plug	3.0 N·m (0.30 kgf·m, 2.2 lbf·ft)	'04 model
Cylinder head cover bolt	10 N·m (1.0 kgf·m, 7 lbf·ft)	
Camshaft holder flange bolt	12 N·m (1.2 kgf·m, 9 lbf·ft)	Apply oil to the threads and flange surface
Cam sprocket bolt	20 N·m (2.0 kgf·m, 14 lbf·ft)	Apply a locking agent to the threads
Cam chain tensioner cap nut	12 N·m (1.2 kgf·m, 9 lbf·ft)	
Cam chain lifter sealing bolt	10 N·m (1.0 kgf·m, 7 lbf·ft)	
Reed valve cover bolt	13 N·m (1.3 kgf·m, 9 lbf·ft)	CT bolt

CYLINDER HEAD/VALVES

TOOLS

<p>Compression gauge attachment 07RMJ-MY50100</p>  <p>or equivalent commercially available in U.S.A.</p>	<p>Valve spring compressor 07757-0010000</p> 	<p>Valve spring compressor attachment 07959-KM30101</p> 
<p>Tappet hole protector 07HMG-MR70002</p>  <p>Not available in U.S.A.</p>	<p>Valve guide reamer, 4.0 mm 07MMH-MV90100</p>  <p>or 07MMH-MV9010A (U.S.A. only)</p>	<p>Seat cutter, 27.5 mm (45° IN) 07780-0010200</p>  <p>or equivalent commercially available in U.S.A.</p>
<p>Seat cutter, 24.5 mm (45° EX) 07780-0010100</p>  <p>or equivalent commercially available in U.S.A.</p>	<p>Flat cutter, 27 mm (32° IN) 07780-0013300</p>  <p>or equivalent commercially available in U.S.A.</p>	<p>Flat cutter, 24 mm (32° EX) 07780-0012500</p>  <p>or equivalent commercially available in U.S.A.</p>
<p>Interior cutter, 26 mm (60° IN) 07780-0014500</p>  <p>or equivalent commercially available in U.S.A.</p>	<p>Interior cutter, (60° EX) 07780-0014202</p>  <p>or equivalent commercially available in U.S.A.</p>	<p>Cutter holder, 4.0 mm 07781-0010500</p>  <p>or equivalent commercially available in U.S.A.</p>

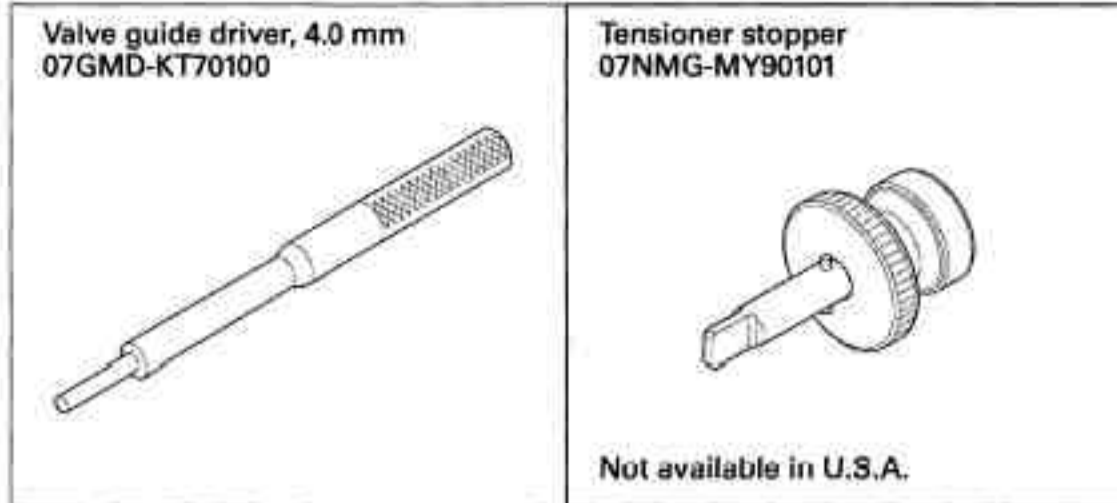

TROUBLESHOOTING

- Engine top-end problems usually affect engine performance. These problem can be diagnosed by a compression test or by tracing engine noises to the top-end with a sounding rod stethoscope.
- If the performance is poor at low speeds, check for white smoke in the crankcase breather hose. If the hose is smoky, check for a seized piston ring (page 13-12).

Compression too low, hard starting or poor performance at low speed

- Valves:
 - Incorrect valve adjustment
 - Burned or bent valve
 - Incorrect valve timing
 - Broken valve spring
 - Uneven valve seating
- Cylinder head:
 - Leaking or damaged head gasket
 - Warped or cracked cylinder head
- Worn cylinder, piston or piston rings (page 13-12)

Compression too high, overheating or knocking

- Excessive carbon build-up on piston crown or on combustion chamber

Excessive smoke

- Cylinder head:
 - Worn valve stem or valve guide
 - Damaged stem seal
- Worn cylinder, piston or piston rings (page 13-12)

Excessive noise

- Cylinder head:
 - Incorrect valve adjustment
 - Sticking valve or broken valve spring
 - Damaged or worn camshaft
 - Loose or worn cam chain
 - Worn or damaged cam chain
 - Worn or damaged cam chain tensioner
 - Worn cam sprocket teeth
- Worn cylinder, piston or piston rings (page 13-12)

Rough idle

- Low cylinder compression

CYLINDER HEAD/VALVES

CYLINDER COMPRESSION TEST

Warm up the engine to normal operating temperature.
Stop the engine and remove the all spark plug caps (page 4-7).

Install a compression gauge into the spark plug hole.

TOOL:

Compression gauge attachment 07RMJ-MY50100 or equivalent commercially available in U.S.A.

Open the throttle all the way and crank the engine with the starter motor until the gauge reading stops rising.

COMPRESSION GAUGE ATTACHMENT

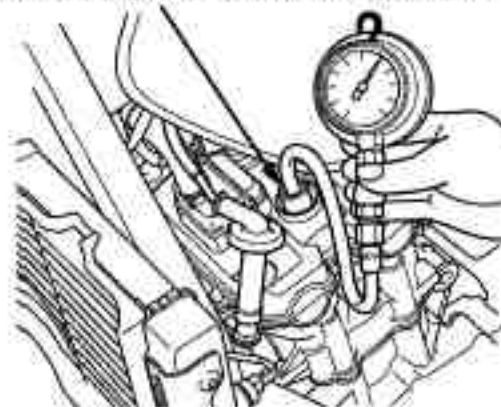

To avoid discharging the battery, do not operate the starter motor for more than seven seconds.

The maximum reading is usually reached within 4 – 7 seconds.

Compression pressure:

1,294 kPa (13.2 kgf/cm², 188 psi) at 350 rpm

Low compression can be caused by:

- Blown cylinder head gasket
- Improper valve adjustment
- Valve leakage
- Worn piston ring or cylinder

High compression can be caused by:

- Carbon deposits in combustion chamber or on piston head

CYLINDER HEAD COVER REMOVAL

Remove the ignition coil (page 18-10).

Remove the crankcase breather hose.
Remove the heat guard rubber.

Disconnect the PAIR air suction hoses from the PAIR reed valve covers.

Remove the cylinder head cover bolts and mounting rubbers.

Remove the cylinder head cover.

CRANK BREATHER HOSE



BOLTS/RUBBERS

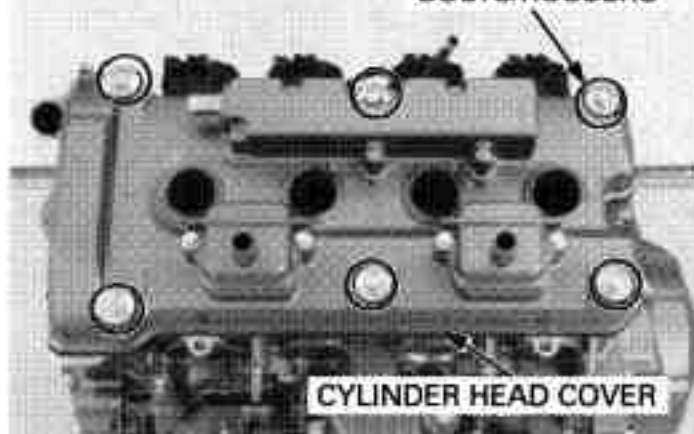

CYLINDER HEAD COVER DISASSEMBLY

Remove the cylinder head cover packing.

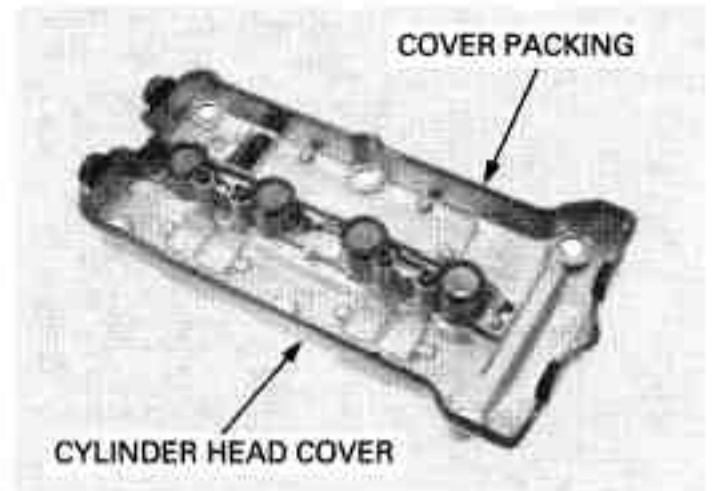

CAMSHAFT REMOVAL

Remove the cylinder head cover (page 9-6).

Remove the timing hole cap and O-ring.

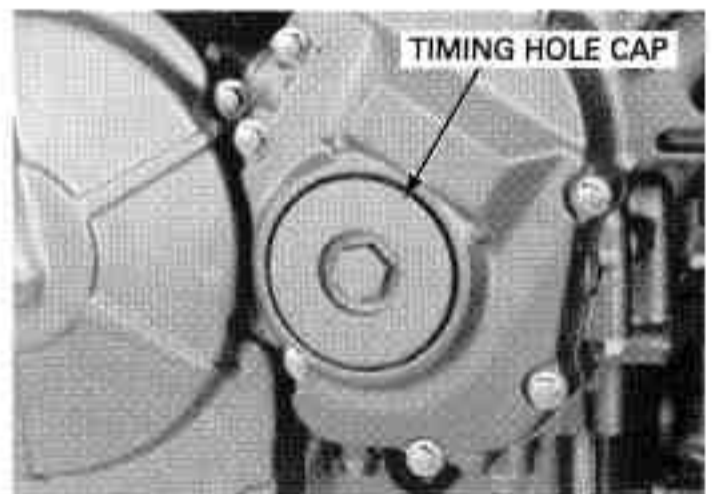

Turn the crankshaft clockwise, align the "T" mark on the ignition pulse generator rotor with the index mark on the right crankcase cover. Make sure the No.1 piston is at TDC (Top Dead Center) on the compression stroke.

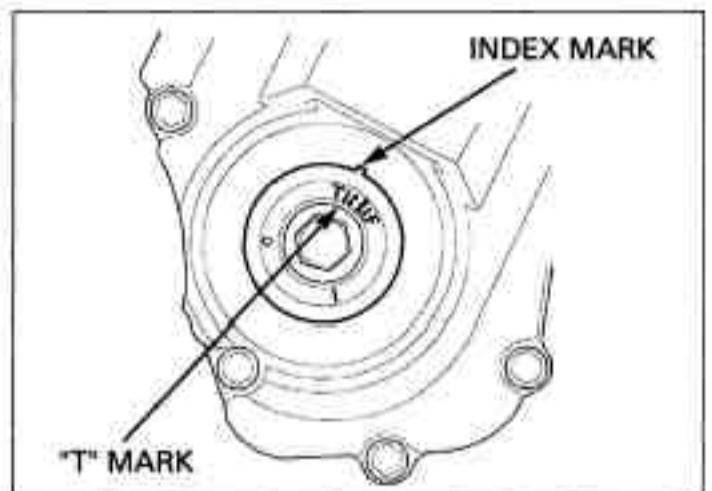

Remove the cam chain tensioner lifter sealing bolt and sealing washer.

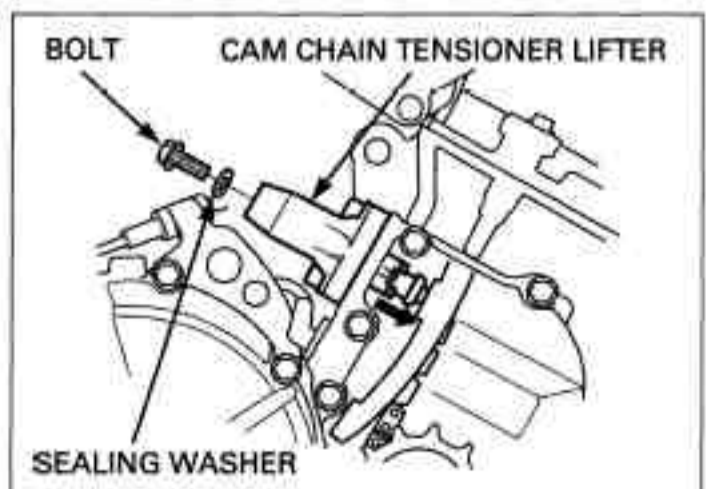

CYLINDER HEAD/VALVES

Turn the tensioner lifter shaft fully in (clockwise) and secure it using the stopper tool.

TOOL:

Tensioner stopper **07NMG-MY90101**
(Not available in U.S.A.)

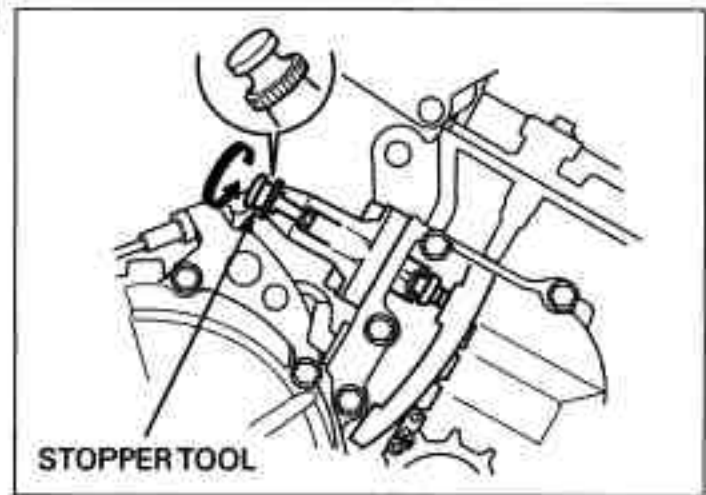

This tool can easily be made from a thin (1 mm thickness) piece of steel.

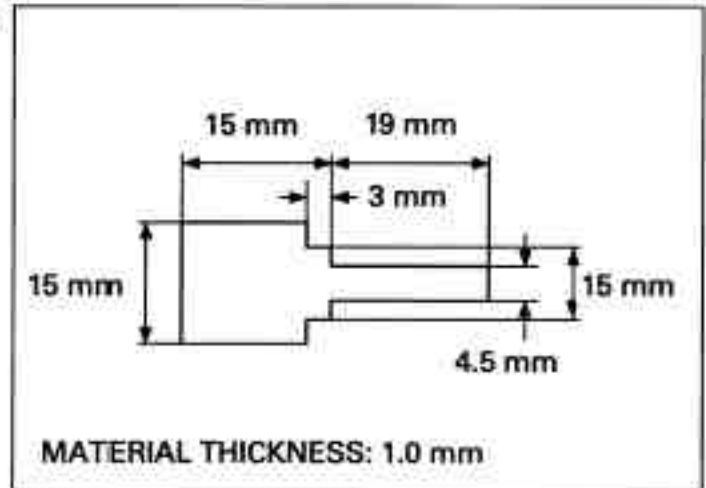

It is not necessary to remove the cam sprocket from the camshaft except when replacing the camshaft and/or cam sprocket.

Be careful not to drop the cam sprocket bolts into the crankcase.

If you plan to replace the camshaft and/or cam sprocket, loosen the cam sprocket bolts as follow:

- Remove the bolts and cam chain guide B.
- Remove the cam sprocket bolts from intake and exhaust camshafts.
- Turn the crankshaft one full turn (360°), remove the other cam sprocket bolts from the camshafts.
- Remove the cam sprocket from the camshaft.

Remove the cam chain guide B bolt.

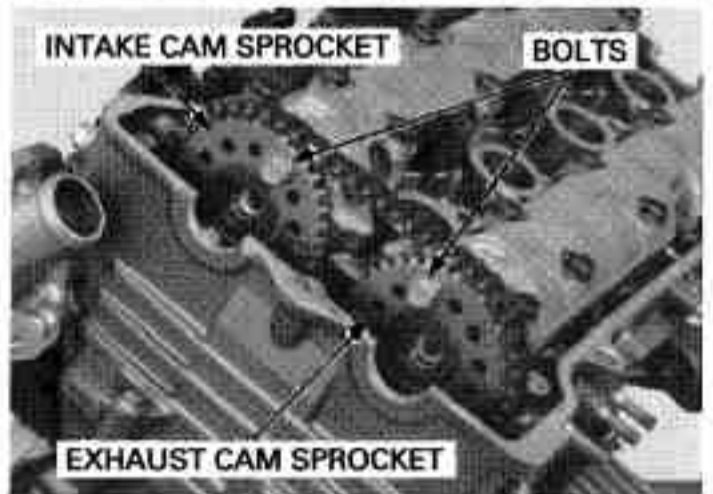
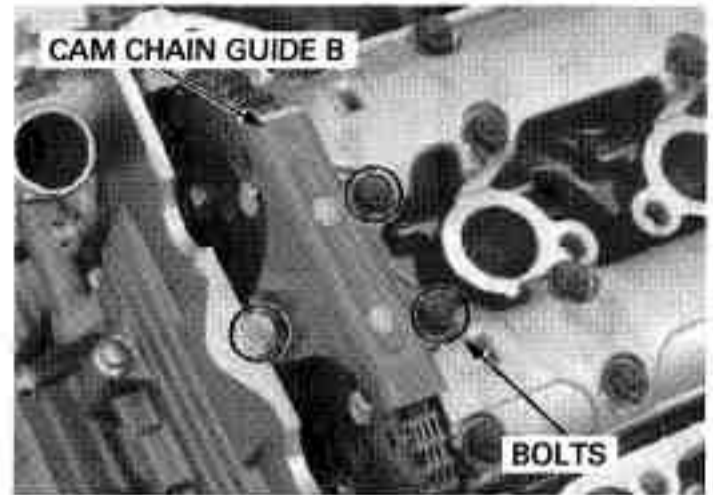

CYLINDER HEAD/VALVES

Loosen and remove the camshaft holder bolts, then remove the camshaft holders and cam chain guide B.

NOTICE

From outside to inside, loosen the bolts in a criss-cross pattern in several steps or the camshaft holder might break.

Do not forcibly remove the dowel pins from the camshaft holder.

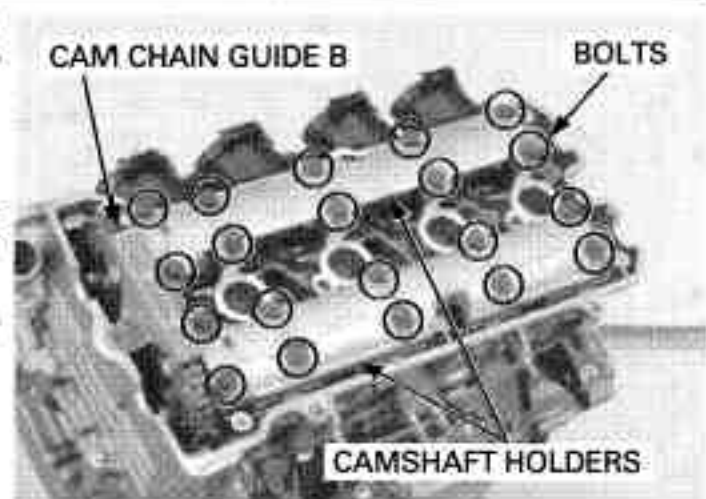

Suspend the cam chain with a piece of wire to prevent the chain from falling into the crankcase.

Remove the cam chain from the cam sprockets and cam shafts.

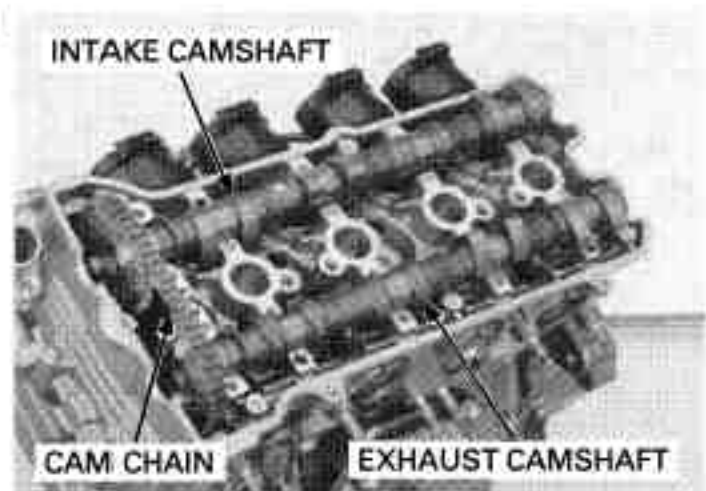

Remove the valve lifters and shims.

- Be careful not to damage the valve lifter bore.
- Shim may stick to the inside of the valve lifter. Do not allow the shims to fall into the crankcase.
- Mark all valve lifters and shims to ensure correct reassembly in their original locations.
- The valve lifter can be easily removed with a valve lapping tool or magnet.
- The shims can be easily removed with a tweezers or magnet.

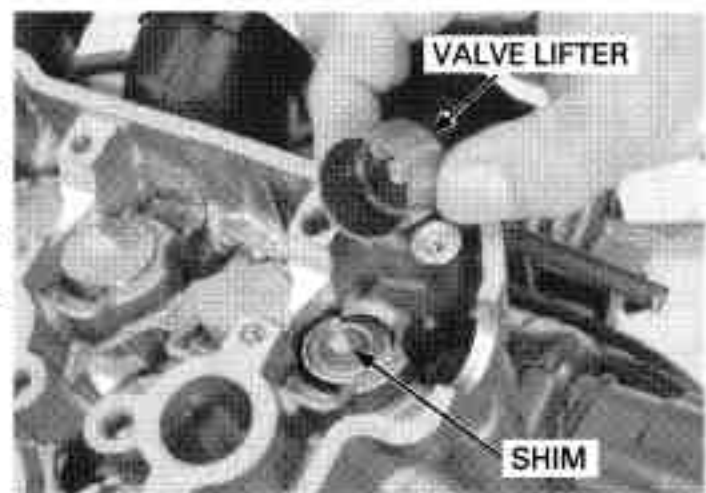

INSPECTION

CAMSHAFT HOLDER

Inspect the bearing surface of camshaft holder for scoring, scratches, or evidence of insufficient lubrication.

Inspect the oil orifices of the holders for clogging.

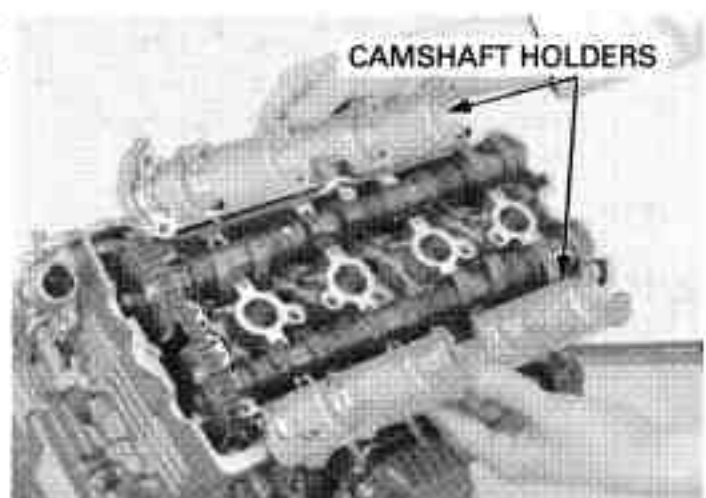

CAM CHAIN GUIDE B

Inspect the cam chain slipper surface of the cam chain guide B for wear or damage.

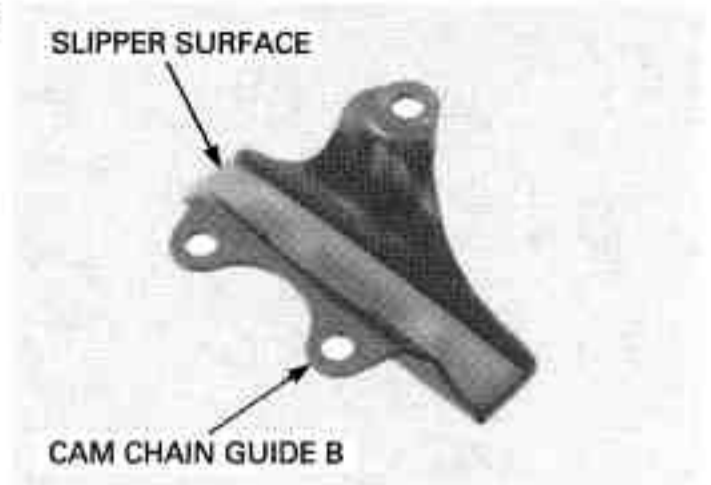

CAMSHAFT

Check the cam and journal surfaces of the camshaft for scoring, scratches or evidence of insufficient lubrication.

Check the oil holes in the camshaft for clogging.

Support both ends of the camshaft with V-blocks and check the camshaft runout with a dial gauge.

SERVICE LIMIT: 0.05 mm (0.002 in)

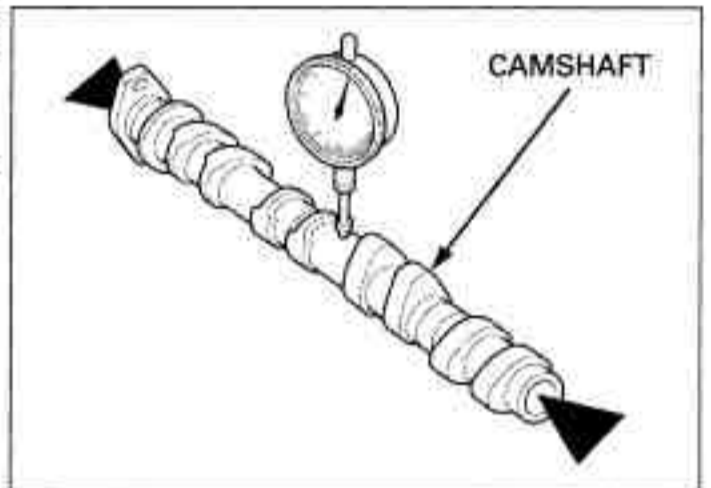

Using a micrometer, measure each cam lobe height.

SERVICE LIMITS:

IN: 36.03 mm (1.419 in)

EX: 35.19 mm (1.385 in)

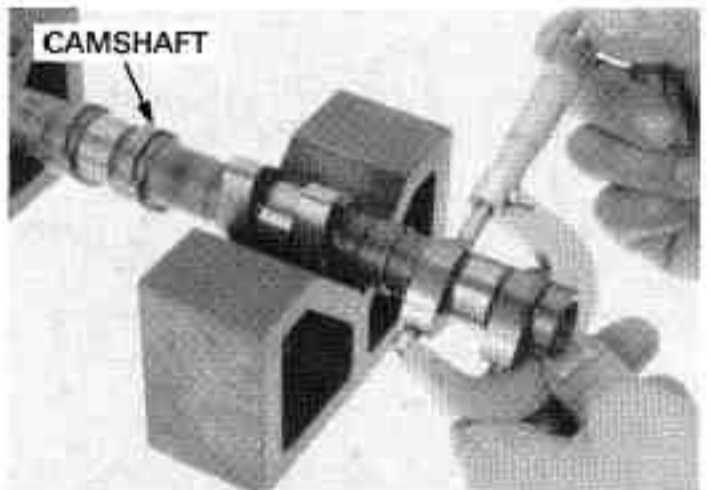

CAMSHAFT OIL CLEARANCE

Remove the cylinder head and valves (page 9-12).

Wipe any oil from the journals of the camshaft, cylinder head and camshaft holders.

Lay a strip of plastigauge lengthwise on top of each camshaft journal.

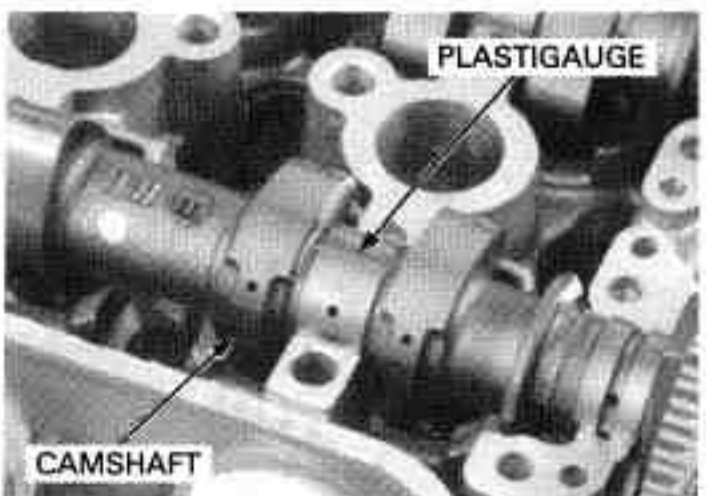

CYLINDER HEAD/VALVES

Do not rotate the camshaft when using plastigauge

Install the camshaft holder onto the camshafts.
Apply engine oil to the threads and seating surfaces of the camshaft holder bolts.

TORQUE: 12 N-m (1.2 kgf-m, 9 lbf-ft)

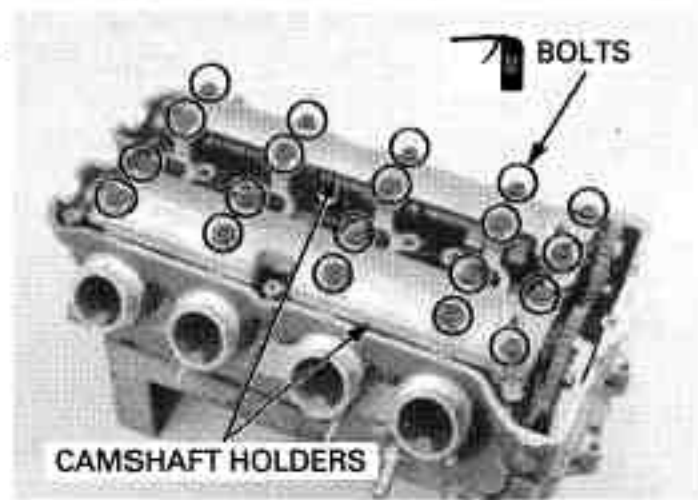

Remove the camshaft holders and measure the width of each plastigauge.
The widest thickness determines the oil clearance.

SERVICE LIMIT: 0.10 mm (0.004 in)

When the service limits are exceeded, replace the camshaft and recheck the oil clearance.
Replace the cylinder head and camshaft holders as a set if the clearance still exceeds the service limit.

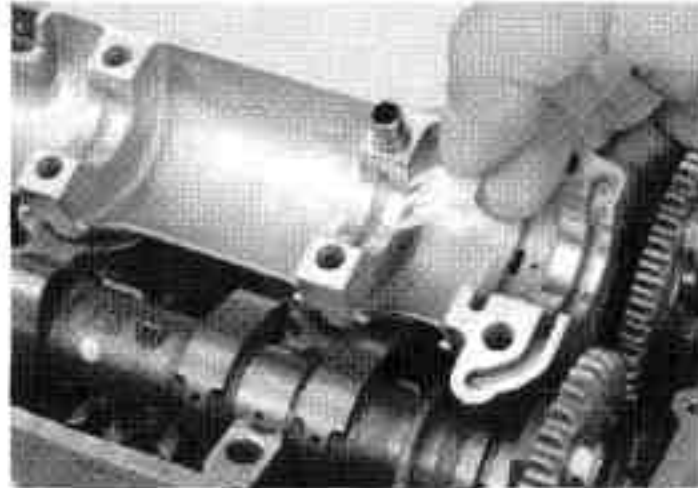

CYLINDER HEAD REMOVAL

Drain the coolant (page 7-6).

Remove the following:

- Exhaust system (page 3-9)
- Carburetor (page 6-10)
- Thermostat housing (page 7-8)
- Radiator (page 7-10)
- Camshaft (page 9-7)

Remove the socket bolts, sealing washers and cam chain tensioner lifter and gasket.



Remove the cam chain tensioner slider cap nut and sealing washer.



Remove the cam chain tensioner slider.



Disconnect the ECT sensor 3P connector.

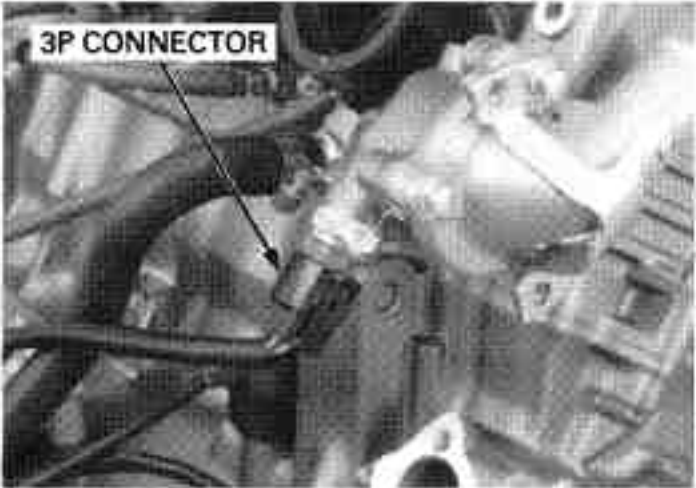

Loosen the band screw and disconnect the bypass hose from the cylinder head.

'04 model only: Disconnect the vacuum hoses from the cylinder head.

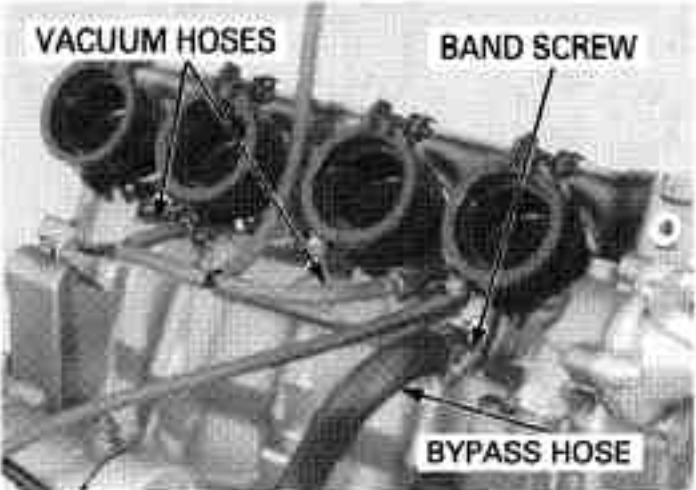

Remove the two 6 mm flange bolts.

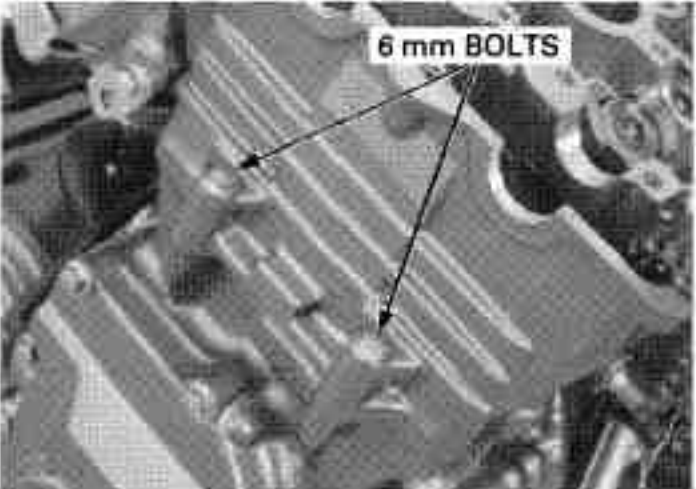

CYLINDER HEAD/VALVES

Loosen the 9 mm bolts in a criss-cross pattern in 2 - 3 steps.

Remove the ten 9 mm bolts/washers.
Remove the cylinder head.

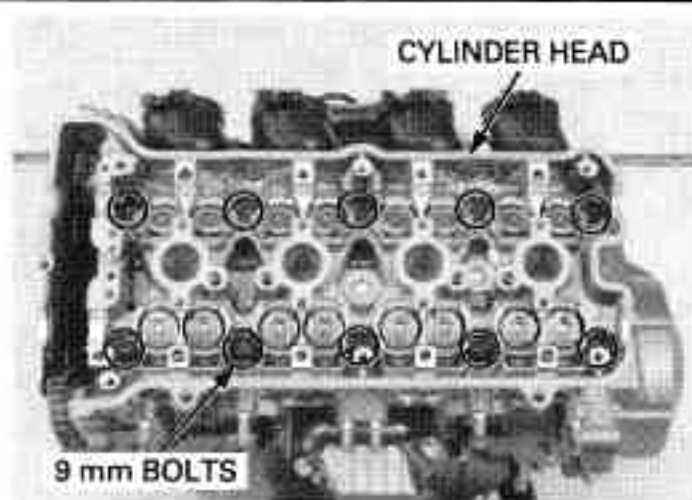

Remove the gasket and dowel pins.

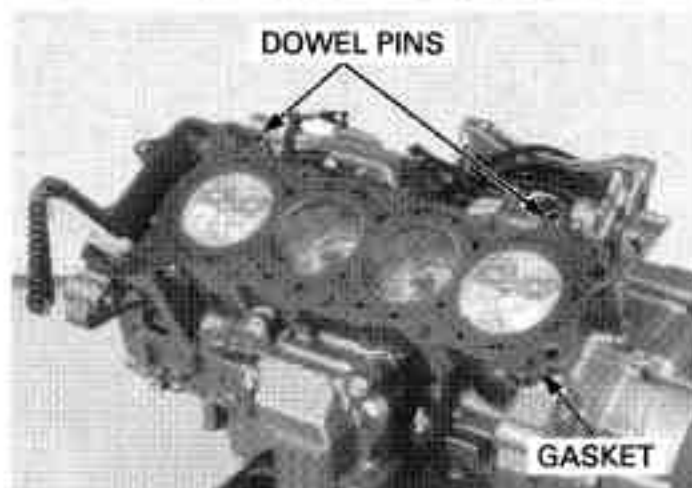

Remove the ignition pulse generator cover and ignition pulse generator rotor (page 18-7).
Remove the bolt, cam chain guide and collar.

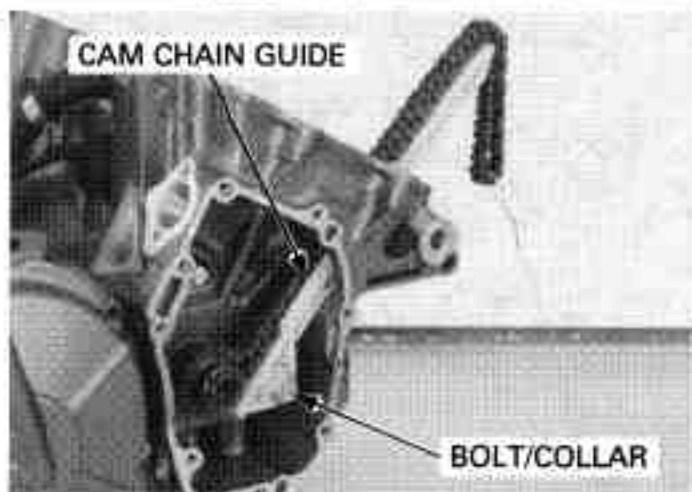

Remove the cam chain and timing sprocket from the crankshaft.

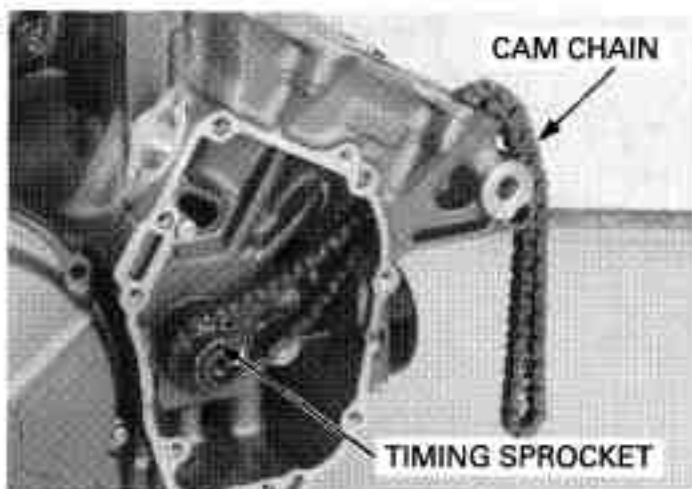

CYLINDER HEAD DISASSEMBLY

Remove the spark plugs from the cylinder head (page 4-7).

Loosen the band screws and remove the carburetor insulators from the cylinder head.

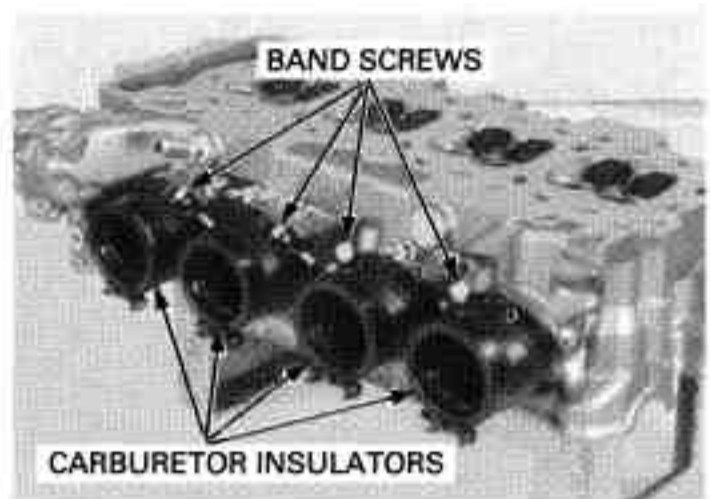

Install the tappet hole protector into the valve lifter bore.

TOOL:

Tappet hole protector 07HMG-MR70002
(Not available in U.S.A.)



An equivalent tool can easily be made from a plastic 35 mm film container as shown.

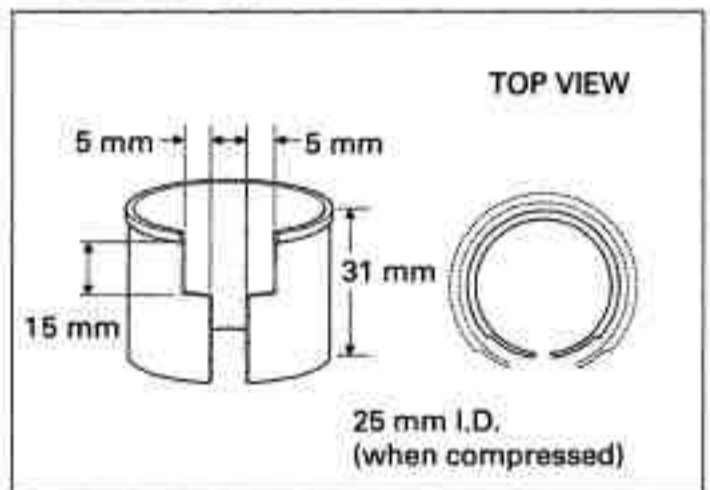

Remove the valve spring cotters using the special tools as shown.

TOOLS:

Valve spring compressor 07757-0010000
Valve spring compressor attachment 07959-KM30101

NOTICE

To prevent loss of tension, do not compress the valve springs more than necessary to remove the cotters.

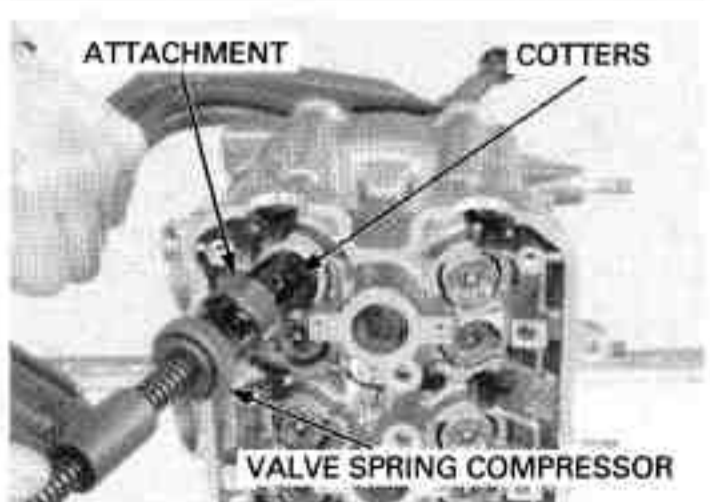

CYLINDER HEAD/VALVES

Mark all parts during disassembly so they can be placed back in their original locations.

Remove the following:

- Spring retainer
- Valve spring
- Valve
- Stem seal
- Valve spring seat

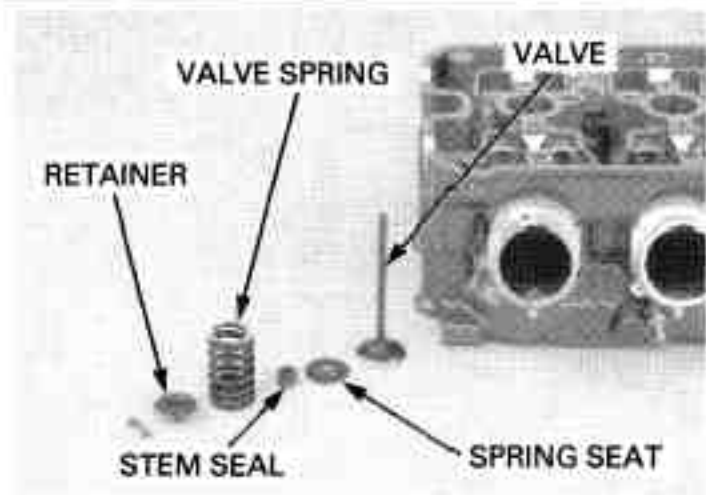

CYLINDER HEAD INSPECTION

CYLINDER HEAD

Avoid damaging the gasket surface.

Remove carbon deposits from the combustion chamber, being careful not to damage the gasket surface. Check the spark plug hole and valve areas for cracks.



Check the cylinder head for warpage with a straight edge and feeler gauge.

SERVICE LIMIT: 0.10 mm (0.004 in)

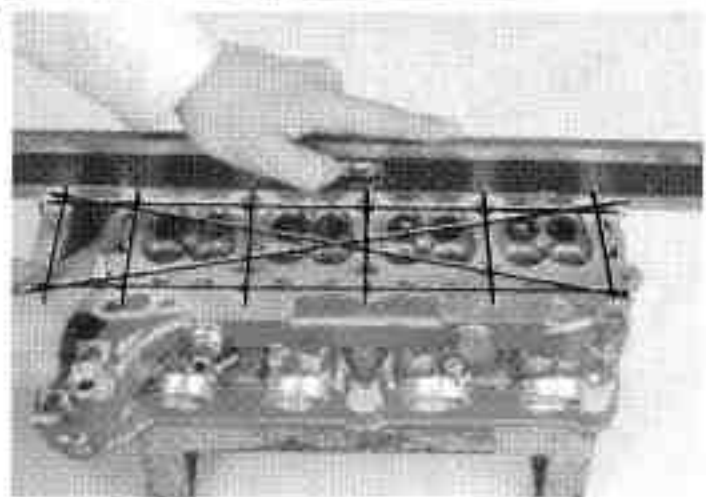

VALVE LIFTER BORE

Inspect each valve lifter bore for scratches or abnormal wear. Measure the each valve lifter bore I.D.

SERVICE LIMIT: 26.04 mm (1.025 in)



VALVE LIFTER

Inspect each valve lifter for scratches or abnormal wear.

Measure the each valve lifter O.D.

SERVICE LIMIT: 25.97 mm (1.022 in)

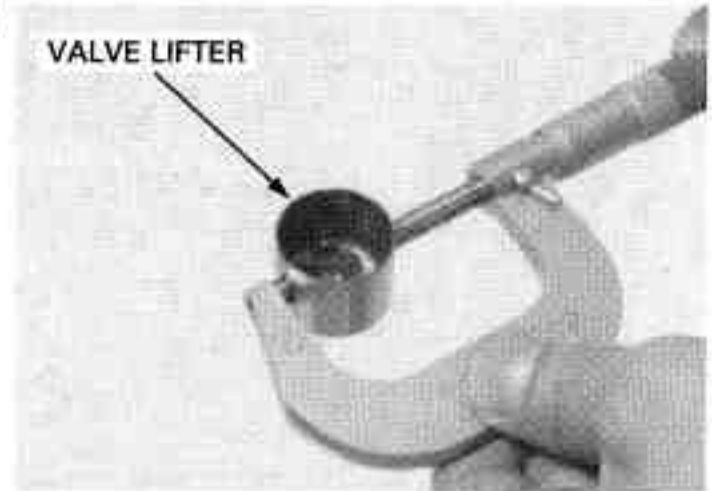

VALVE SPRING

Measure the valve spring free length.

SERVICE LIMITS:

IN: 37.05 mm (1.46 in)

EX: 37.05 mm (1.46 in)

Replace the springs if they are shorter than the service limits.

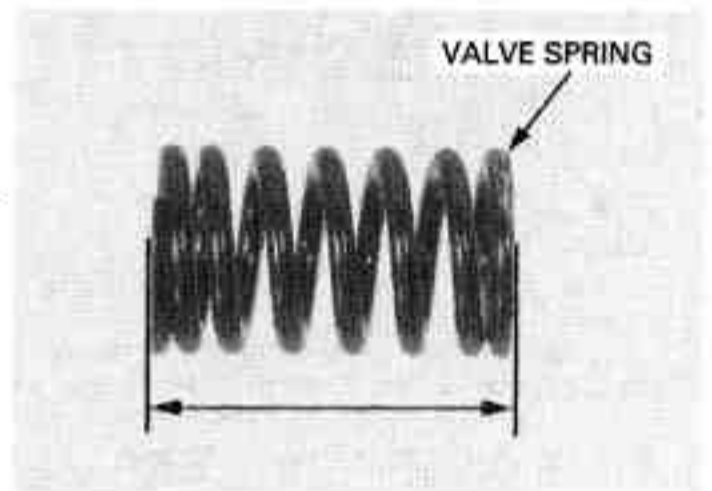

CAM CHAIN TENSIONER/CAM CHAIN GUIDE

Inspect the cam chain tensioner and cam chain guide for excessive wear or damage, replace if necessary.

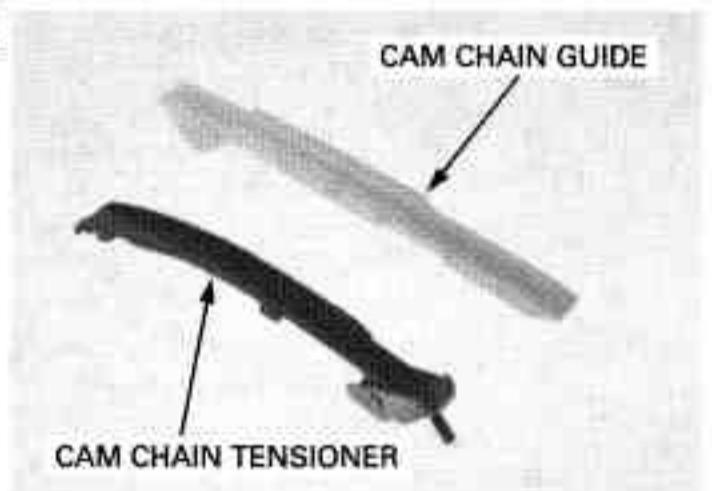

VALVE/VALVE GUIDE

Check that the valve moves smoothly in the guide. Inspect each valve for bending, burning or abnormal stem wear.

Check valve movement in the guide, measure and record each valve stem O.D.

SERVICE LIMITS:

IN: 3.965 mm (0.1561 in)

EX: 3.955 mm (0.1557 in)

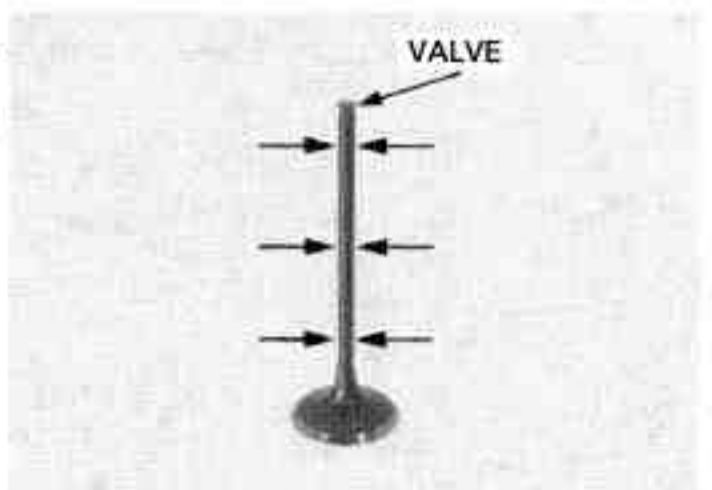

CYLINDER HEAD/VALVES

Ream the guides to remove any carbon deposits before checking clearances. Insert the reamer from the combustion chamber side of the head and always rotate the reamer clockwise.

TOOL:

Valve guide reamer, 4.0 mm 07MMH-MV90100 or 07MMH-MV9010A (U.S.A. only)

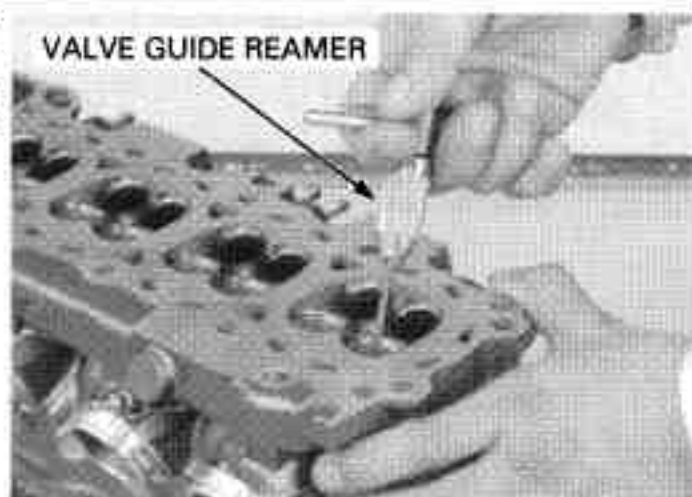

Measure and record each valve guide I.D.

SERVICE LIMITS: IN/EX: 4.04 mm (0.159 in)

Subtract each valve stem O.D. from the corresponding guide I.D. to obtain the stem-to-guide clearance.

SERVICE LIMITS:

IN: 0.075 mm (0.0030 in)

EX: 0.085 mm (0.0033 in)

Reface the valve seats whenever the valve guides are replaced (page 9-20).

If the stem-to-guide clearance is out of service limits, determine if a new guide with standard dimensions would bring the clearance within tolerance. If so, replace any guides as necessary and ream to fit. If the stem-to-guide clearance is out of standard with the new guides, replace the valves and guides.

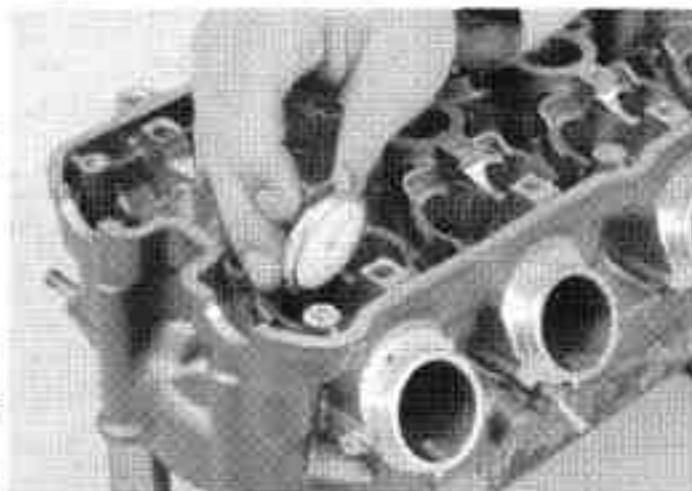

VALVE GUIDE REPLACEMENT

Chill the replacement valve guides in the freezer section of a refrigerator for about one hour. Heat the cylinder head to 100 – 150°C (212 – 300°F) with a hot plate or oven.

NOTICE

Do not use a torch to heat the cylinder head; it may cause warping.

Support the cylinder head and drive out the valve guides from combustion chamber side of the cylinder head.

TOOL:

Valve guide driver, 4.0 mm 07GMD-KT70100

Drive in the guide to the specified depth from the top of the cylinder head.

SPECIFIED DEPTH:

IN: 13.10 – 13.30 mm (0.516 – 0.524 in)

EX: 11.30 – 11.50 mm (0.445 – 0.453 in)

TOOL:

Valve guide driver, 4.0 mm 07GMD-KT70100

Let the cylinder head cool to room temperature.

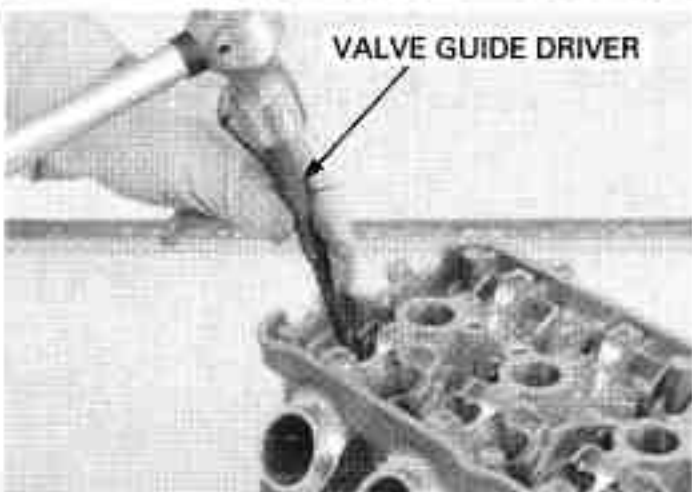
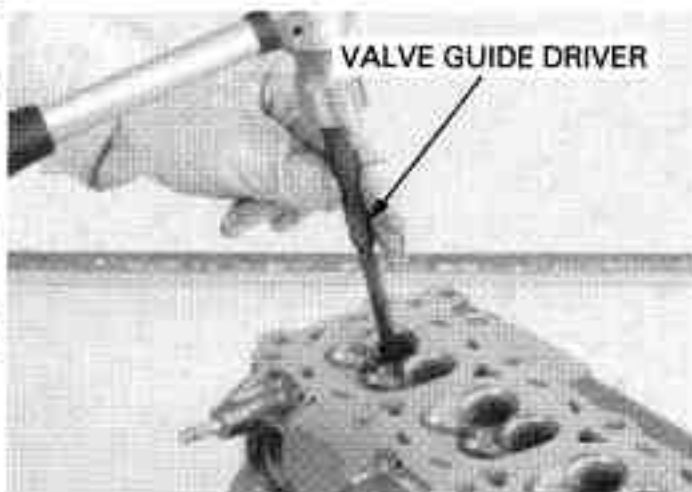

Use cutting oil on the reamer during this operation

Ream the new valve guide after installation. Insert the reamer from the combustion chamber side of the head and also always rotate the reamer clockwise.

TOOL:

Valve guide reamer, 4.0 mm 07MMH-MV90100 or 07MMH-MV9010A (U.S.A. only)

Clean the cylinder head thoroughly to remove any metal particles.
Reface the valve seat (page 9-20).



VALVE SEAT INSPECTION/REFACING

Clean the intake and exhaust valves thoroughly to remove carbon deposits. Apply a light coating of Prussian Blue to the valve seats. Tap the valves and seats using a rubber hose or other hand-lapping tool.

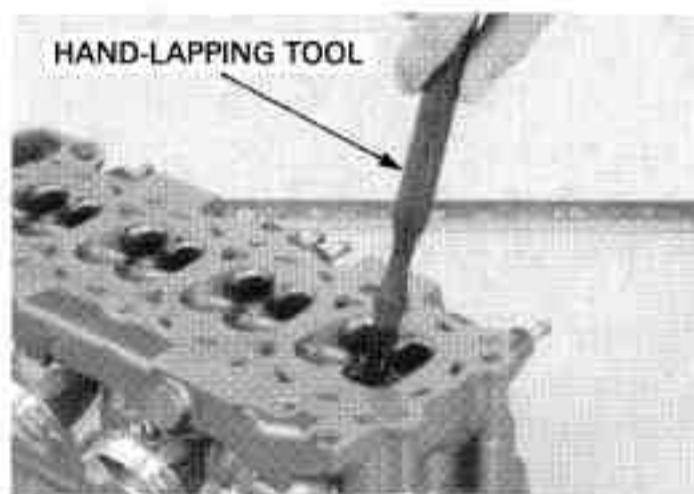

Remove the valve and inspect the valve seat face. The valve seat contact should be within the specified width and even all around the circumference.

STANDARD: 0.90 – 1.10 mm (0.035 – 0.043 in)

SERVICE LIMIT: 1.5 mm (0.06 in)

If the seat width is not within specification, reface the valve seat (page 9-20).

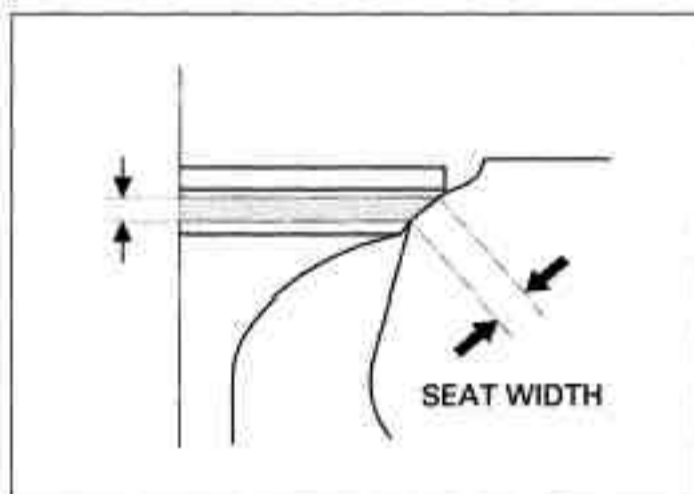

Inspect the valve seat face for:

- Uneven seat width:
 - Replace the valve and reface the valve seat.
- Damaged face:
 - Replace the valve and reface the valve seat.

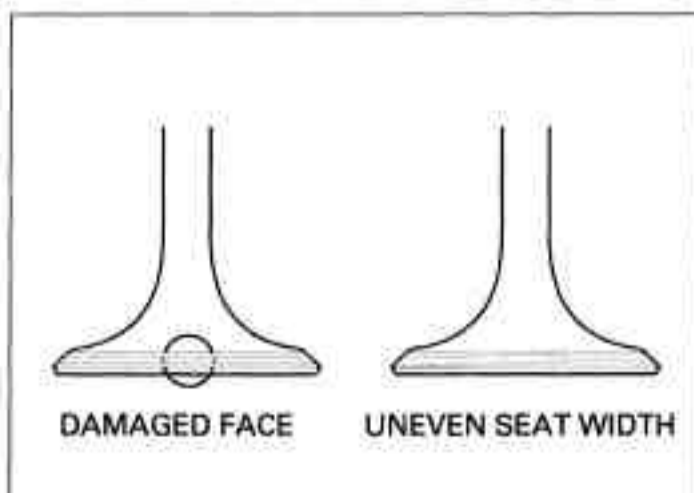

CYLINDER HEAD/VALVES

The valves cannot be ground. If a valve face is burned or badly worn or if it contacts the seat unevenly, replace the valve.

- Contact area (too high or too low)
 - Reface the valve seat.

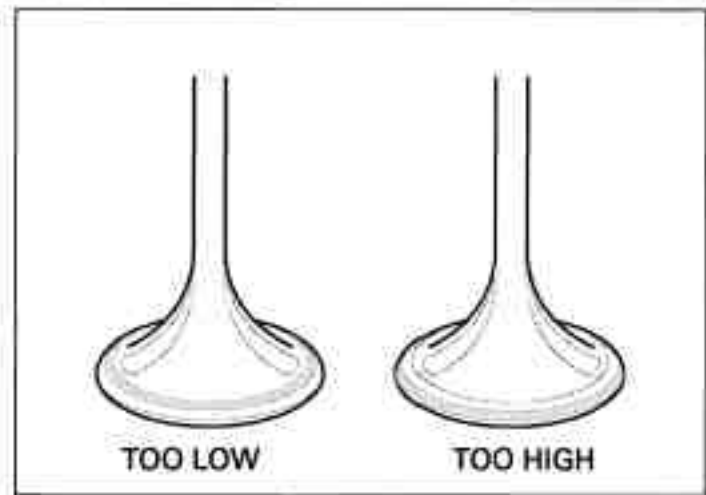

VALVE SEAT REFACING

Follow the refacing manufacturer's operating instructions.

Valve seat cutters/grinders or equivalent valve seat refacing equipment are recommended to correct worn valve seats.

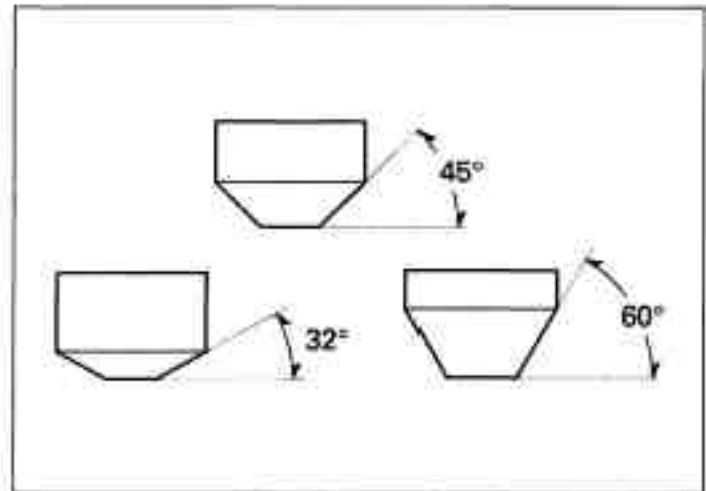

If the contact area is too high on the valve, the seat must be lowered using a 32° flat cutter.

If the contact area is too low on the valve, the seat must be raised using a 60° interior cutter.

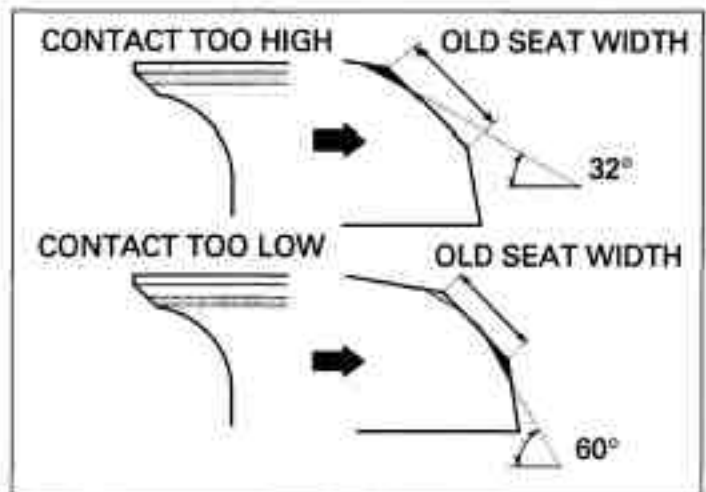

Reface the seat with a 45-degree cutter whenever a valve guide is replaced.

Use a 45-degree cutter to remove any roughness or irregularities from the seat.

TOOLS:

Seat cutter, 27.5 mm (IN) 07780-0010200

Seat cutter, 24.5 mm (EX) 07780-0010100

Cutter holder, 4.0 mm 07781-0010500 or equivalent commercially available in U.S.A.

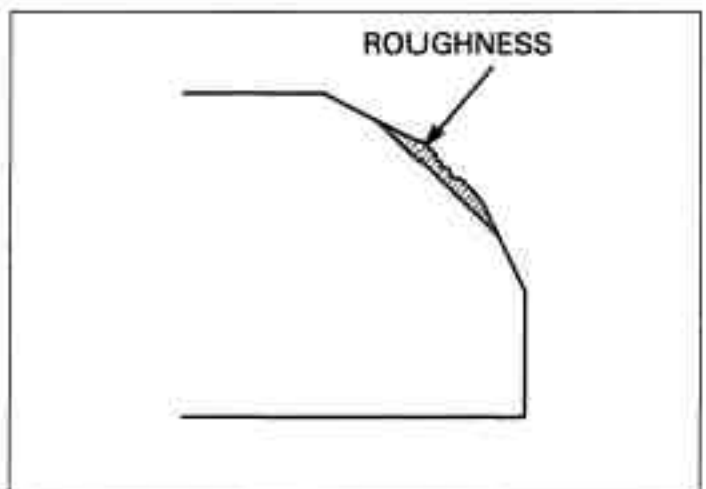

Use a 32-degree cutter to remove the top 1/4 of the existing valve seat material.

TOOLS:

- Flat cutter, 27 mm (IN) 07780-0013300
- Flat cutter, 24 mm (EX) 07780-0012500
- Cutter holder, 4.0 mm 07781-0010500 or equivalent commercially available in U.S.A.

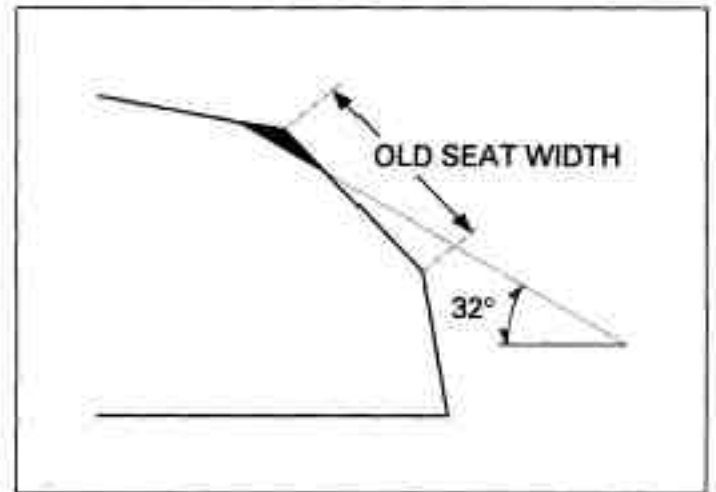

Use a 60-degree cutter to remove the bottom 1/4 of the old seat.

TOOLS:

- Interior cutter, 26 mm (IN) 07780-0014500
- Interior cutter, 22 mm (EX) 07780-0014202
- Cutter holder, 4.0 mm 07781-0010500 or equivalent commercially available in U.S.A.

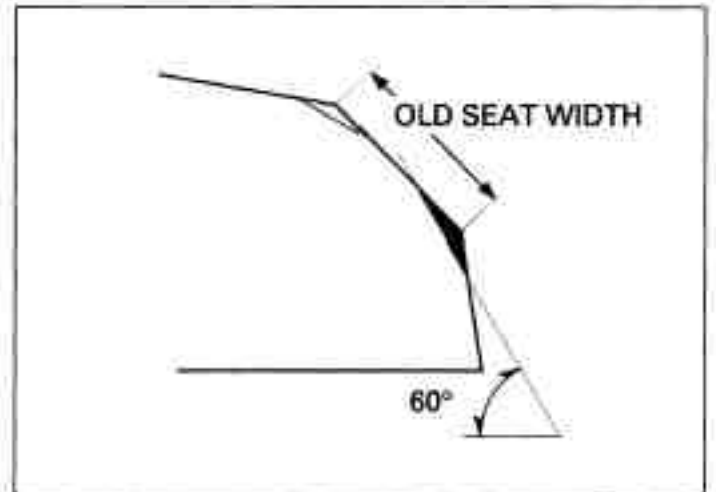

Using a 45° seat cutter, cut the seat to the proper width. Make sure that all pitting and irregularities are removed. Refinish if necessary.

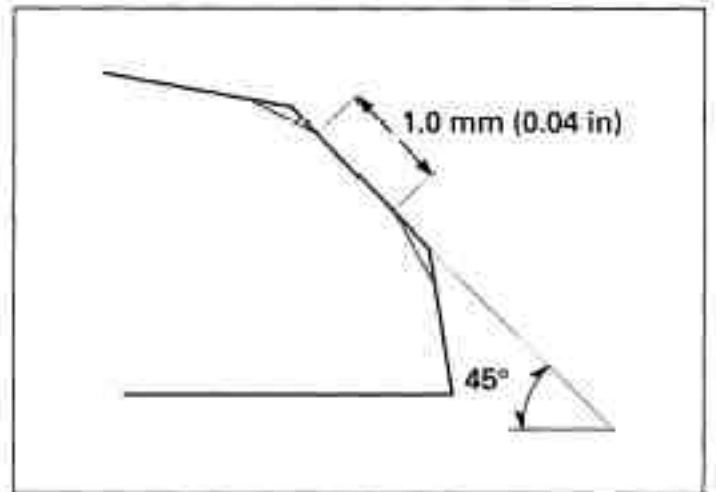

After cutting the seat, apply lapping compound to the valve face, and lap the valve using light pressure.

NOTICE

- Excessive lapping pressure may deform or damage the seat.
- Change the angle of lapping tool frequently to prevent uneven seat wear.
- Do not allow lapping compound to enter the guides.

After lapping, wash all residual compound off the cylinder head and valve.

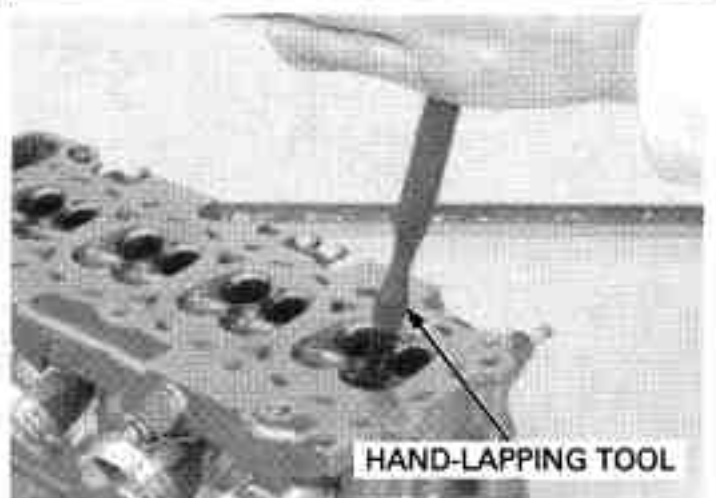

CYLINDER HEAD ASSEMBLY

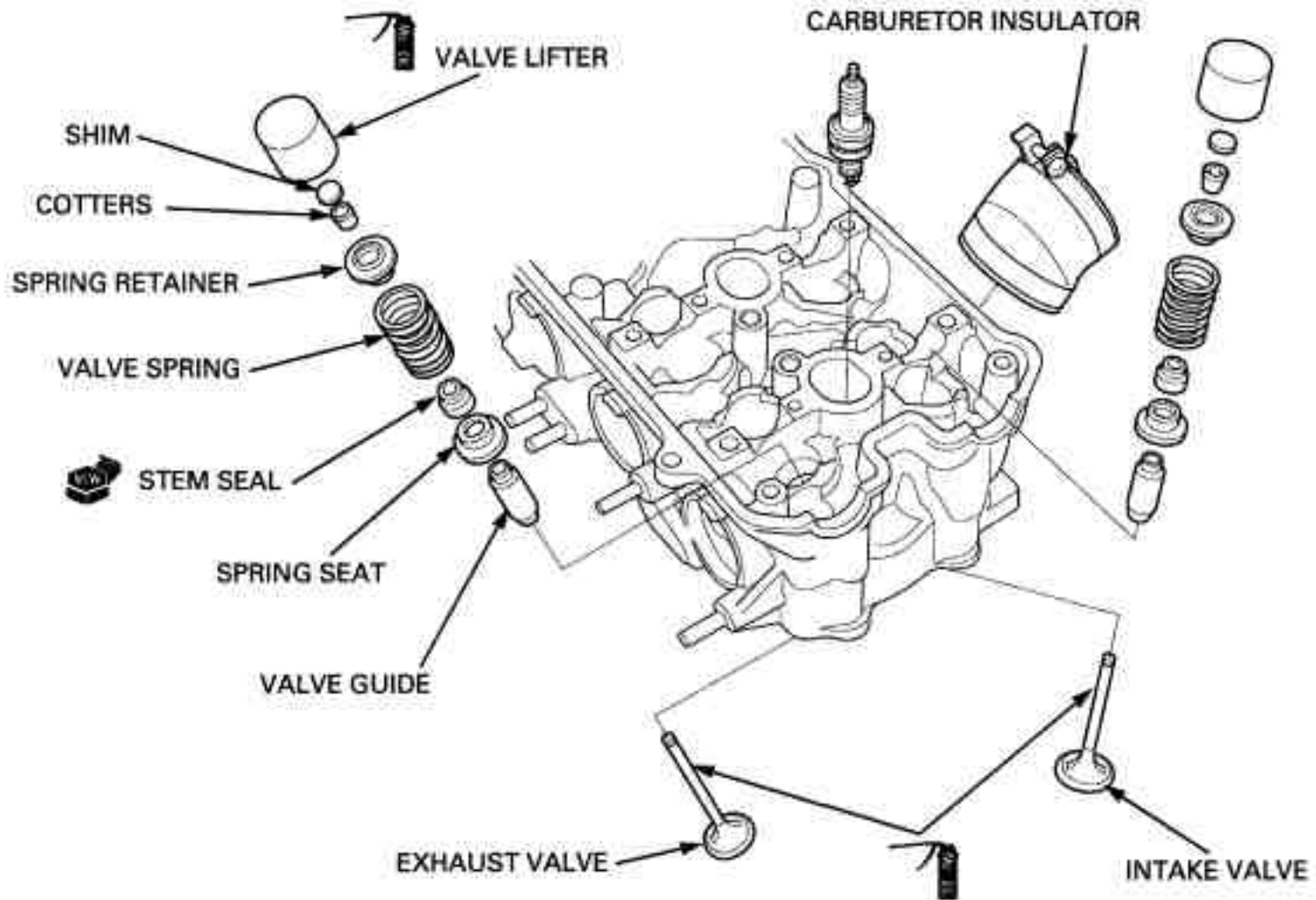

Clean the cylinder head assembly with solvent and blow through all oil passages with compressed air.

Blow through all oil passages in the cylinder head with compressed air.

Install the special tool or equivalent (page 9-15) into the valve lifter bore.

TOOL:

Tappet hole protector 07HMG-MR70002
(Not available in U.S.A.)



Install the valve spring seats.
Install the new stem seals.

Lubricate the valve stems with molybdenum oil solution.

Insert the valve into the valve guide while turning it slowly to avoid damage to the stem seal.

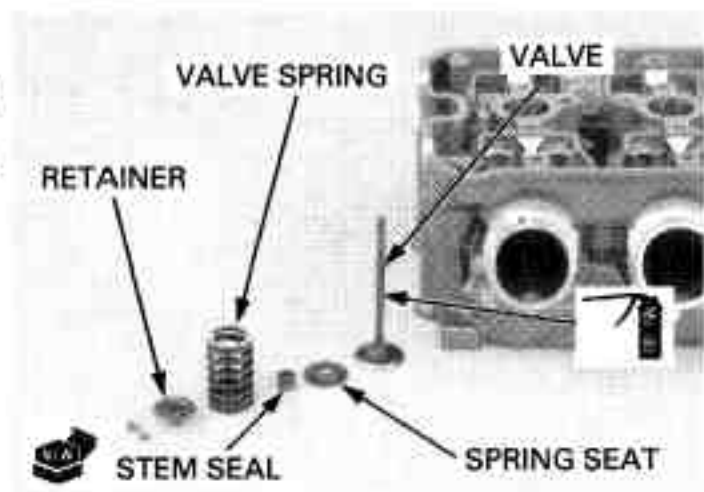

Install the valve spring with the tightly wound coils facing the combustion chamber.
Install the valve spring retainer.

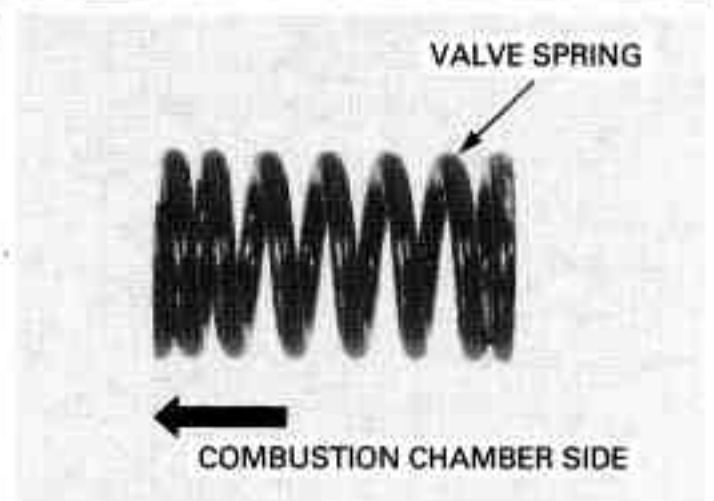

Grease the cotters to ease installation.

Install the valve cotters using the special tool as shown.

NOTICE

To prevent loss of tension, do not compress the valve spring more than necessary.

TOOLS:

- Valve spring compressor **07757-0010000**
- Valve spring compressor attachment **07959-KM30101**

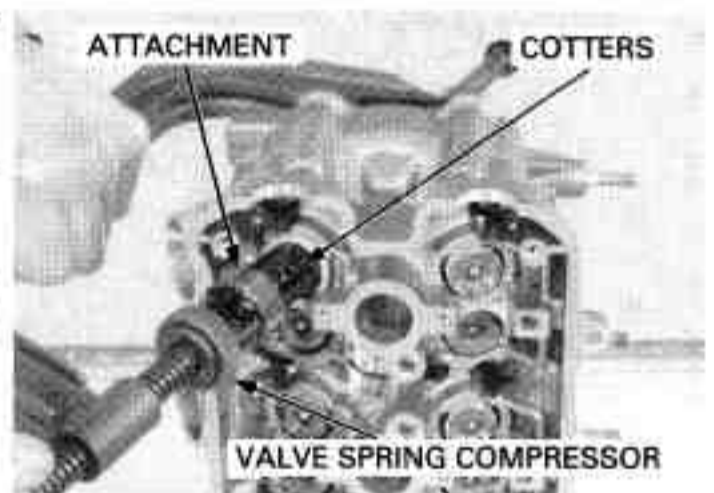

Support the cylinder head above the work bench surface to prevent possible valve damage.

Tap the valve stems gently with two plastic hammers as shown to seat the cotters firmly.

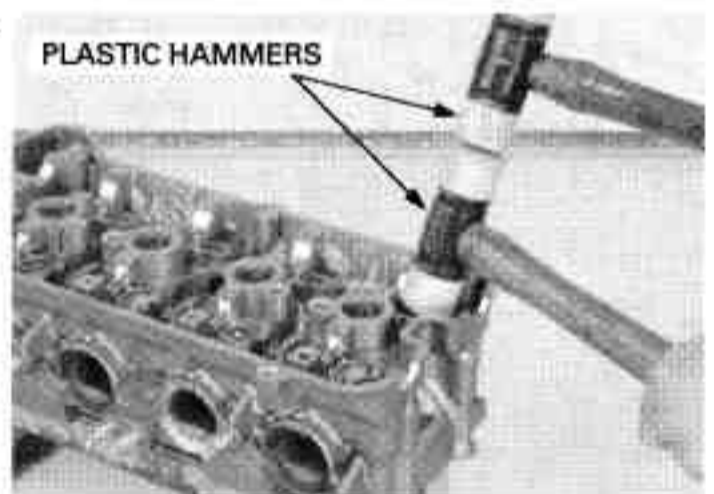

Install the insulators aligning their grooves with the bosses on the cylinder head.

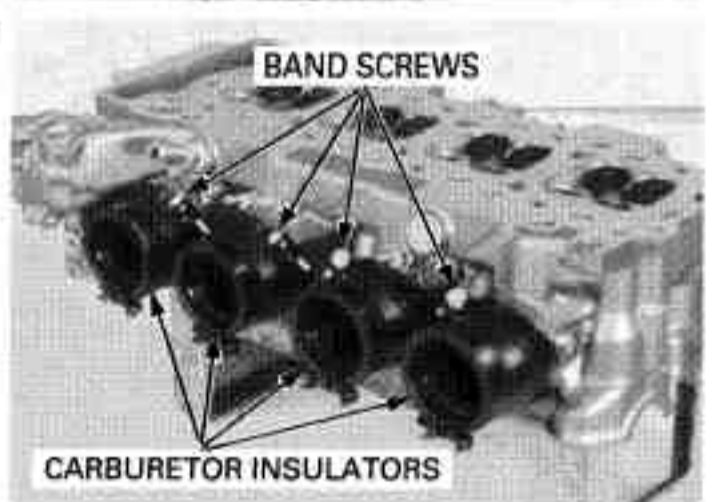

CYLINDER HEAD/VALVES

Tighten the band screws so that the band ends clearance is 4 ± 1 mm (0.2 ± 0.04 in).

Install and tighten the spark plugs.

TORQUE: 12 N·m (1.2 kgf·m, 9 lbf·ft)

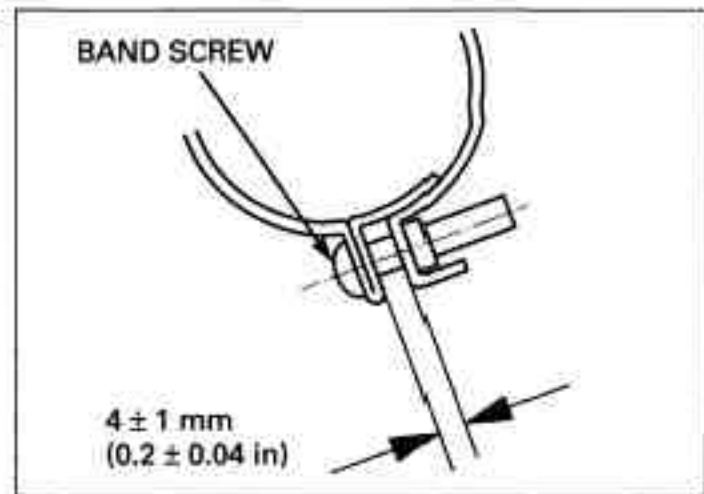

CYLINDER HEAD INSTALLATION

Install the timing sprocket by aligning the wide teeth between the crankshaft and sprocket.



Install the cam chain to the timing sprocket teeth.

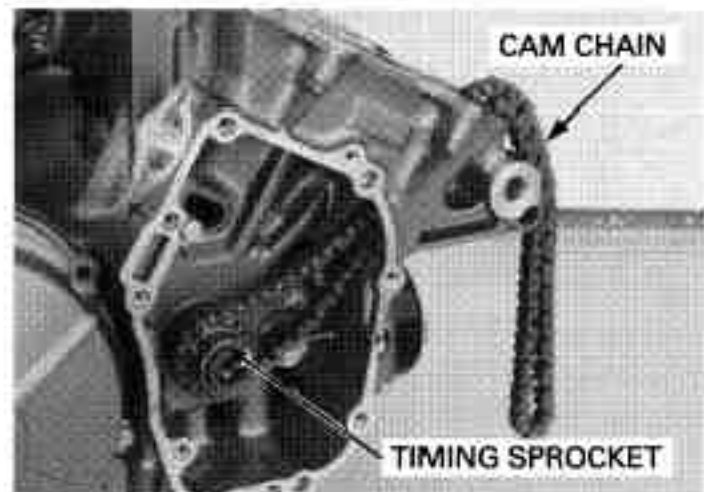

Install the cam chain guide, collar and tighten the bolt securely.

Install the ignition pulse generator rotor cover (page 18-8).

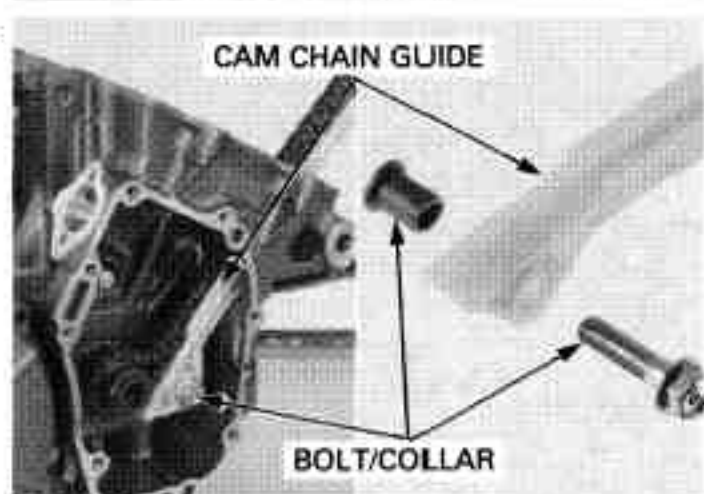

Install the dowel pins and a new cylinder head gasket as shown.

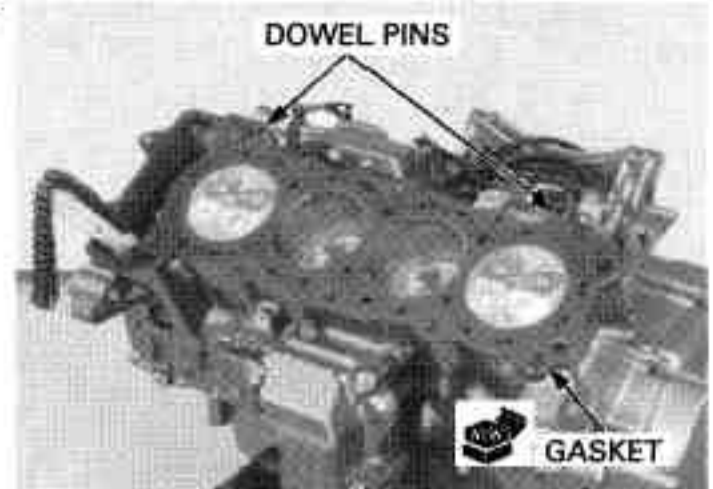

Install the cylinder head onto the cylinder block.

Apply oil to the threads and seating surface of the 9 mm bolts/washers and install them.

Tighten the 9 mm bolts in a crisscross pattern in 2 – 3 steps to the specified torque.

TORQUE: 47 N·m (4.8 kgf·m, 35 lbf·ft)

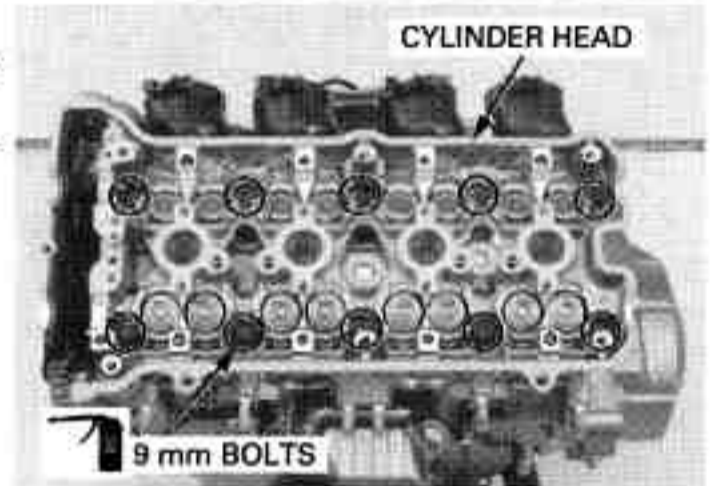

Install and tighten the 6 mm bolts securely.

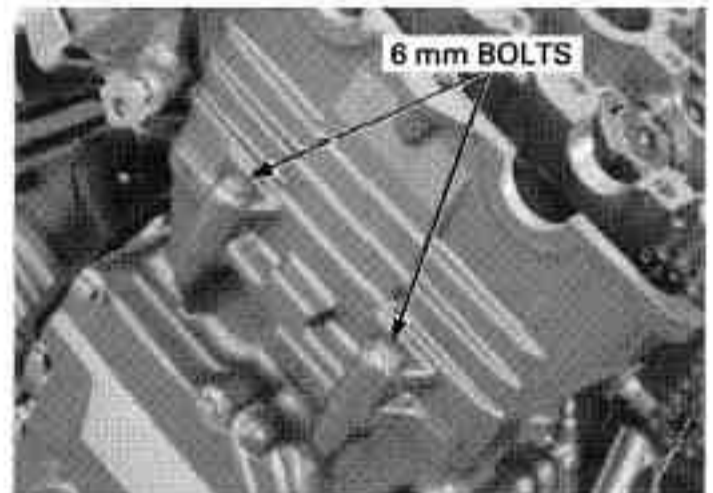

'04 model only: Connect the vacuum hoses to the cylinder head.

Connect the bypass hose to the cylinder head and tighten the band screw securely.

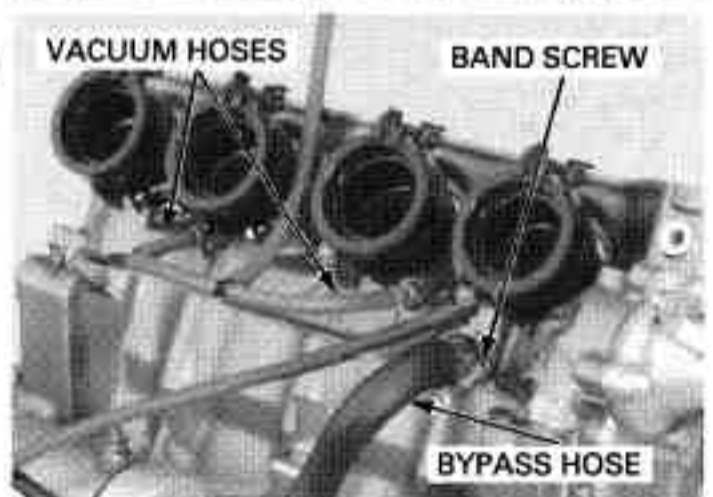

CYLINDER HEAD/VALVES

Connect the ECT sensor 3P connector.

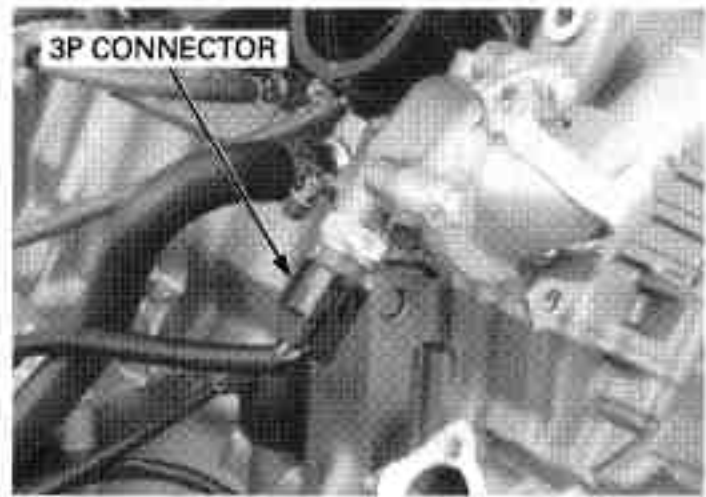

Install the cam chain tensioner slider.

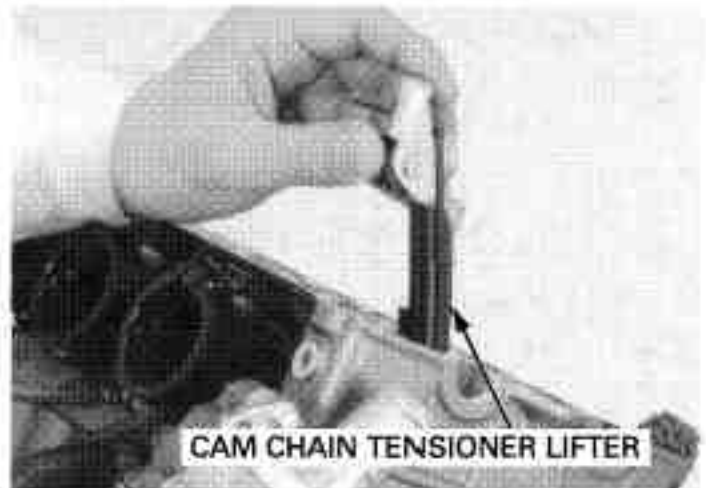

Install the cam chain tensioner slider cap nut with the new sealing washer.
Tighten the cam chain tensioner slider cap nut to the specified torque.

TORQUE: 12 N·m (1.2 kgf·m, 9 lbf·ft)



Install the cam chain tensioner lifter onto the cylinder head with new gasket.

Install new sealing washers and tighten the mounting bolts securely.

Install the following:

- Camshaft (page 9-27)
- Radiator (page 7-15)
- Thermostat housing (page 7-9)
- Carburetor (page 6-34)
- Exhaust system (page 3-9)

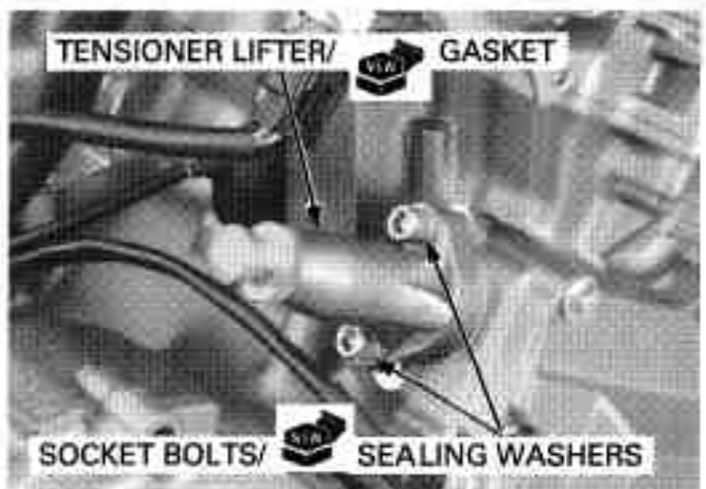

CAMSHAFT INSTALLATION

Apply molybdenum oil solution to the outer surface of the each valve lifter.

Install the shims and valve lifters in their original locations.

Install the shims and valve lifters into the valve lifter bores.

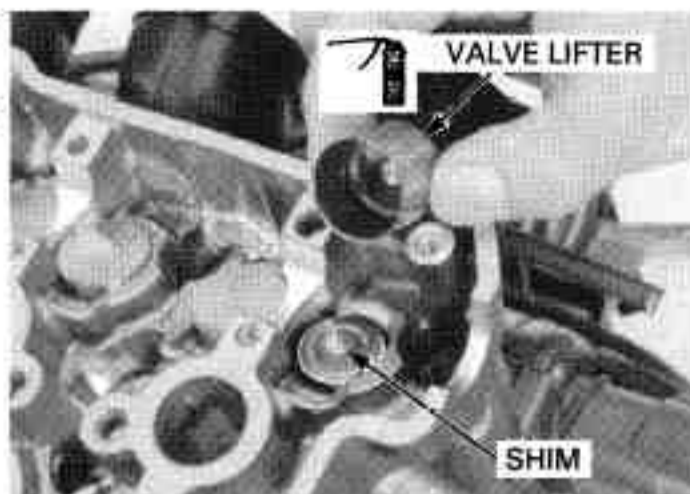

If the cam sprockets are removed, install the cam sprockets onto the camshafts.

- Install the intake cam sprocket with the timing mark (IN) facing outward and the No.4 cam lobes facing up as shown.
- Install the exhaust cam sprocket with the timing mark (EX) facing outward and the No.4 cam lobes facing up as shown.

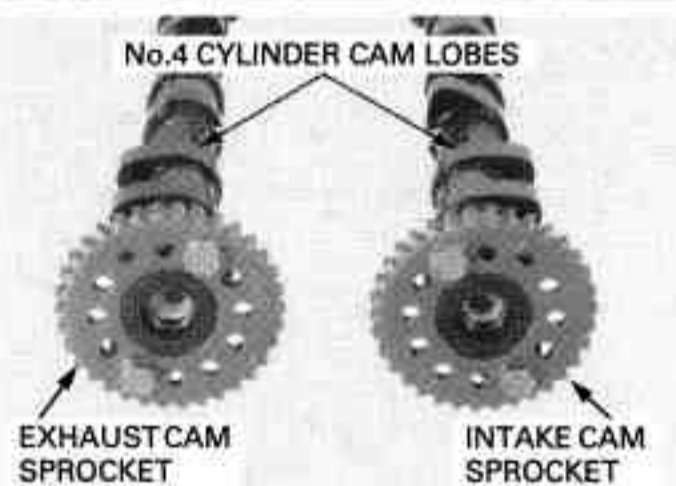

- The marks on the camshaft have the following meanings.
 - "IN": Intake camshaft
 - "EX": Exhaust camshaft

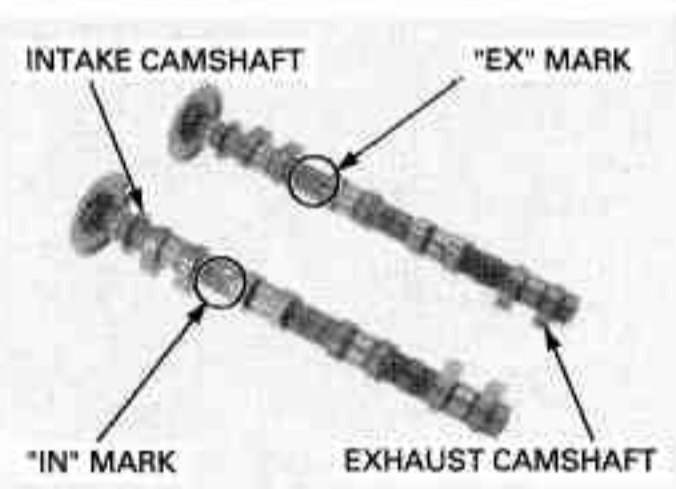

Clean and apply a locking agent to the cam sprocket bolt threads.
Install the cam sprocket bolts.

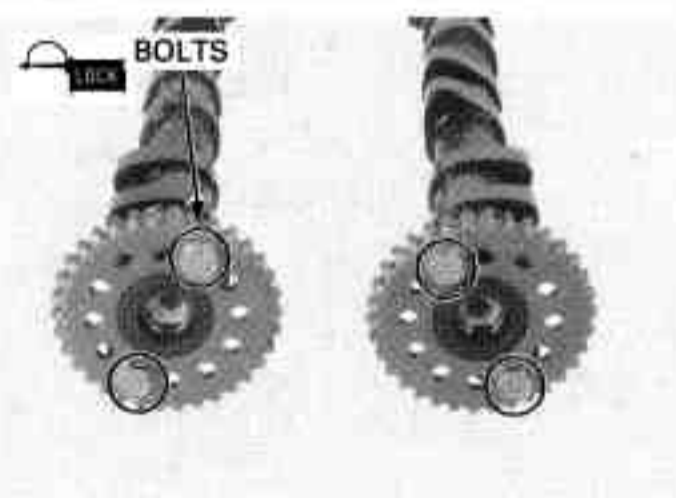

CYLINDER HEAD/VALVES

Turn the crankshaft clockwise and align the "T" mark on the ignition pulse generator rotor with the index mark on the ignition pulse generator rotor cover.

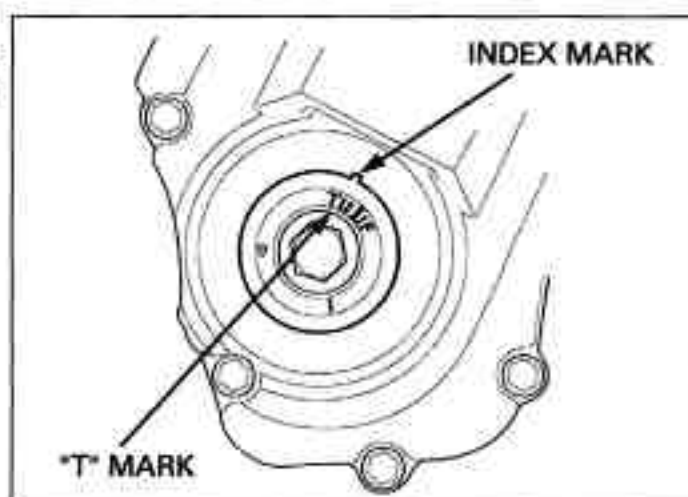

Apply molybdenum oil solution to the camshaft journals of the cylinder head and camshaft holder.

Install the cam chain over the cam sprockets and then install the intake and exhaust camshafts.

Make sure that the timing marks on the cam sprockets are facing outward and flush with the cylinder head upper surface as shown.

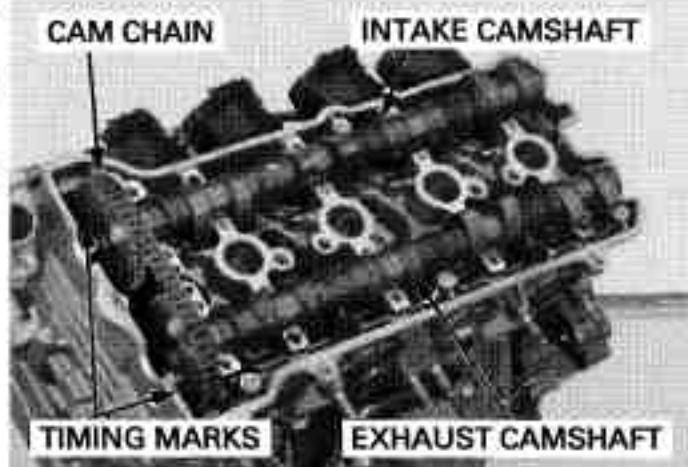

- The marks on the camshaft holder have the following meanings.
 - "IN": Intake camshaft holder
 - "EX": Exhaust camshaft holder

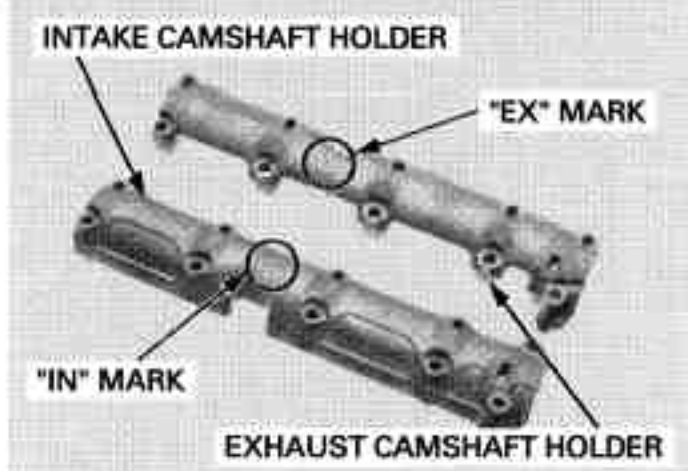

Apply molybdenum oil solution to the camshaft journals of the cylinder head and camshaft holder.

Install the camshaft holder onto the camshafts.

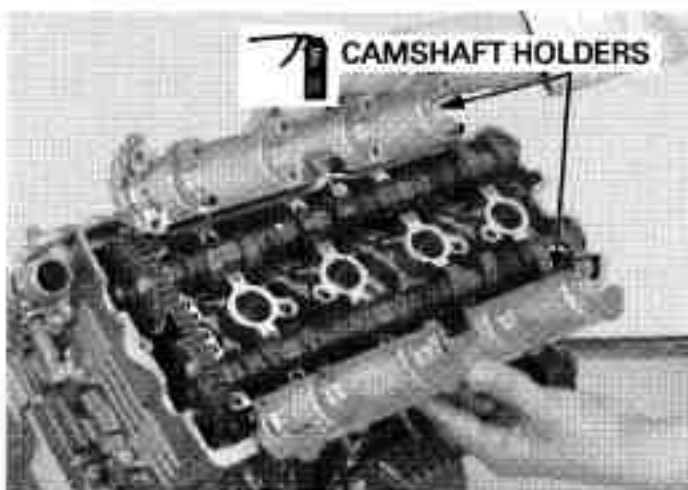

Install the cam chain guide B.

Apply engine oil to the threads and seating surfaces of the camshaft holder bolts.

Finger tighten the bolts.

Tighten the all camshaft holder bolts in the numerical order marked on the camshaft holder.

TORQUE: 12 N·m (1.2 kgf·m, 9 lbf·ft)

Be sure the dowel pins in the camshaft holder align properly with the holes in the cylinder head.

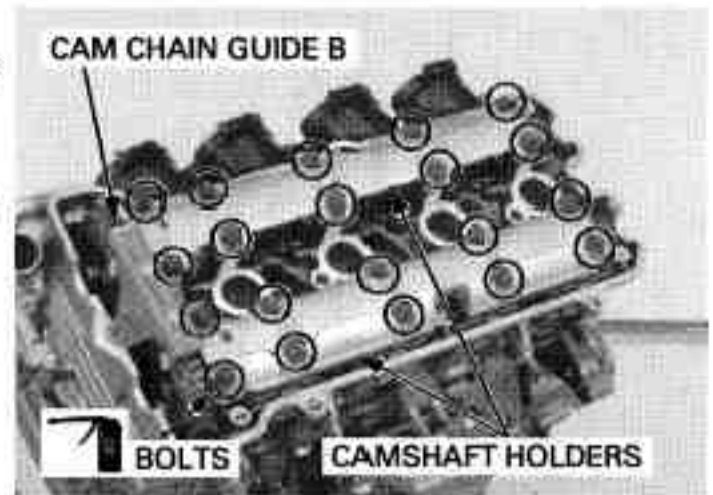

Install and tighten the bolt securely.



In case the cam sprockets were removed, tighten the cam sprocket bolts to the specified torque.

TORQUE: 20 N·m (2.0 kgf·m, 14 lbf·ft)

Turn the crankshaft clockwise one full turn (360°) and tighten the other cam sprocket bolts.

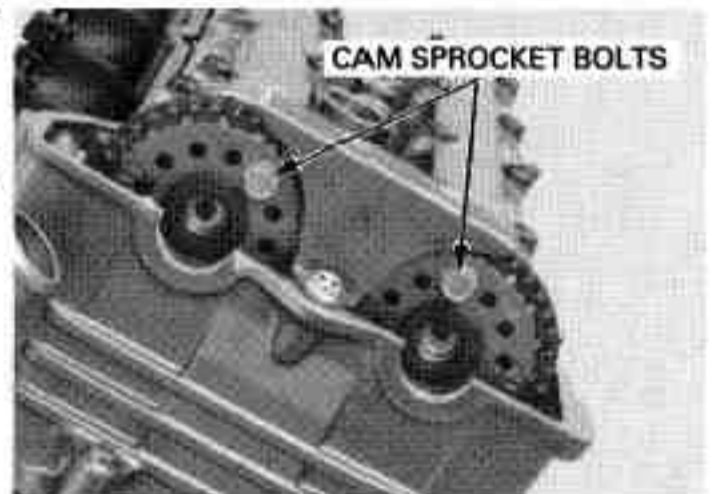

Remove the stopper tool from the cam chain tensioner lifter.

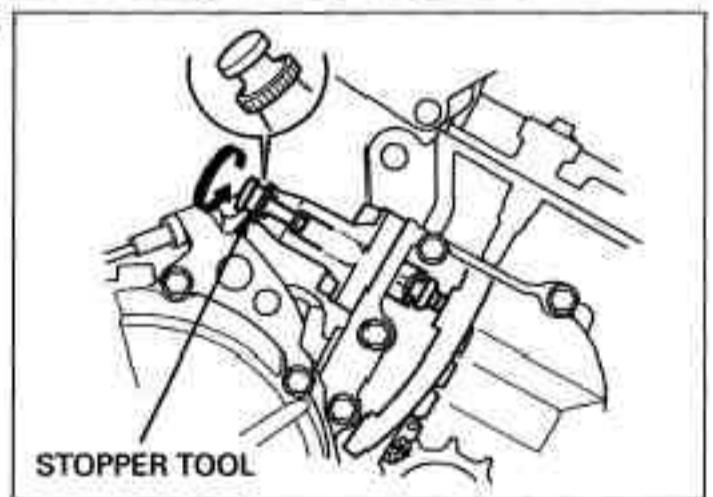

CYLINDER HEAD/VALVES

Install a new sealing washer and tighten the sealing bolt.

Recheck the valve timing.

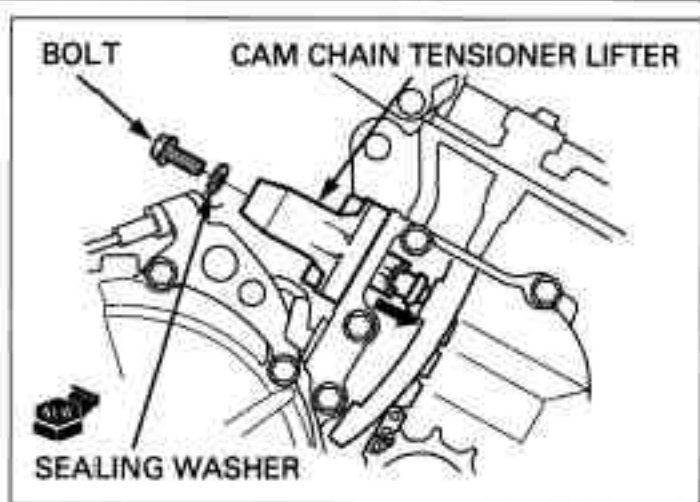

CYLINDER HEAD COVER ASSEMBLY

Install the cylinder head packing into the groove of the cylinder head cover.

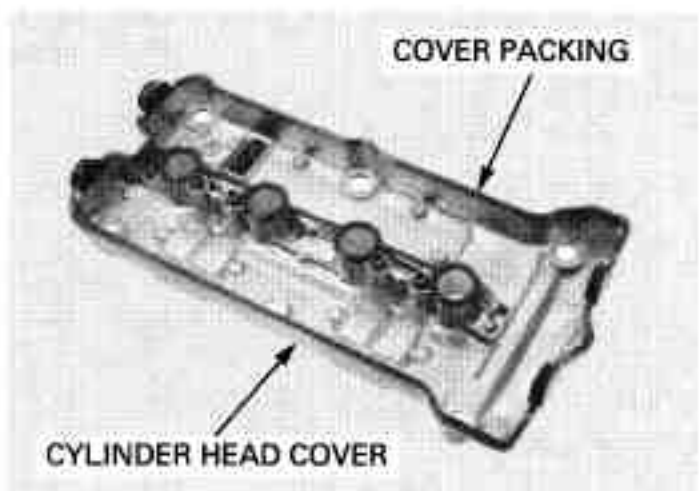

CYLINDER HEAD COVER INSTALLATION

Apply sealant to the cylinder head semi-circular cut-outs as shown.

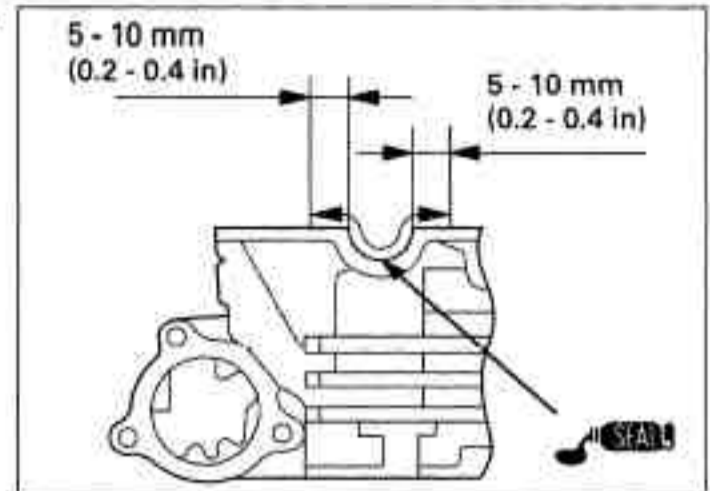

Install the cylinder head cover onto the cylinder head.



Install the washers with their "UP" mark facing up.

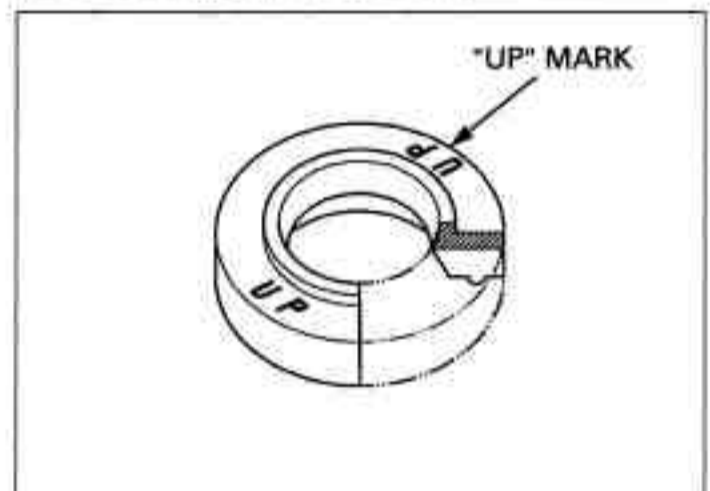

Install and tighten the cylinder head cover special bolts to the specified torque.

TORQUE: 10 N·m (1.0 kgf·m, 7 lbf·ft)

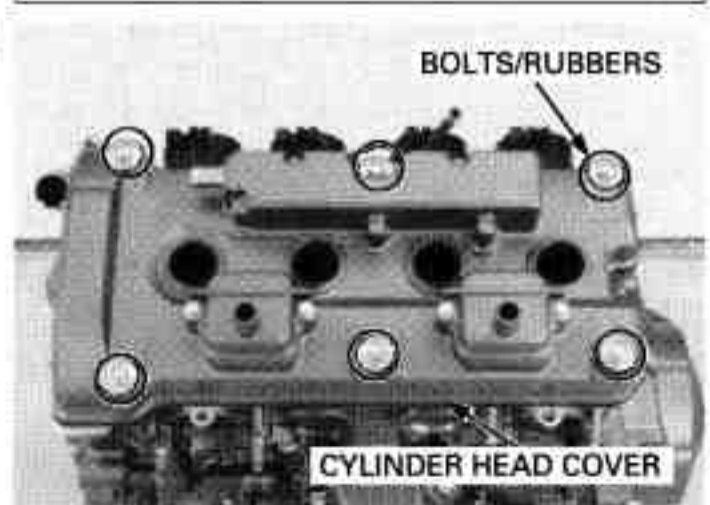

CYLINDER HEAD/VALVES

Install the heat guard rubber.
Install the crankcase breather hose.

Connect the air suction hoses to the PAIR reed valve covers.
Install the ignition coil (page 18-10).



CAM CHAIN TENSIONER LIFTER

REMOVAL

Remove the cam chain tensioner sealing bolt and sealing washer.

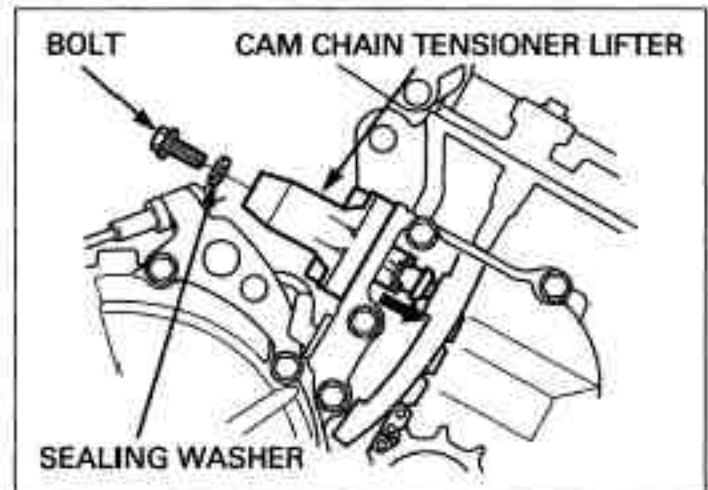

Turn the tensioner shaft fully in (clockwise) and secure it using the stopper tool (page 9-8) to prevent damaging the cam chain.

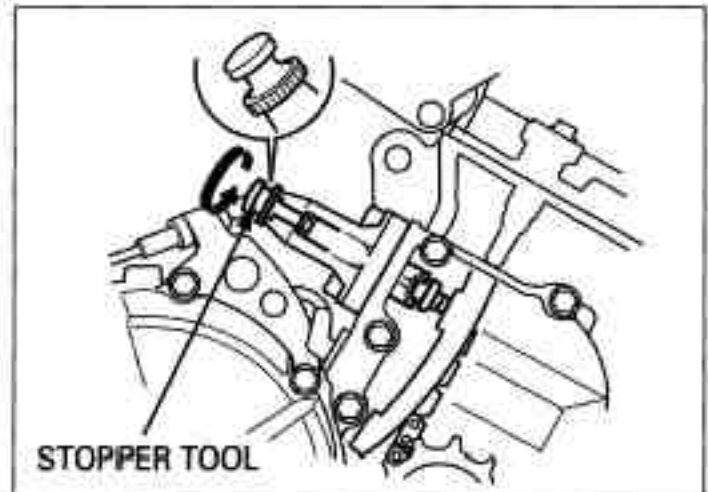

Remove the socket bolts, sealing washers and cam chain tensioner lifter.
Remove the gasket.



INSTALLATION

Note the installation direction of the gasket.

Install a new gasket onto the cam chain tensioner lifter.



Install the cam chain tensioner lifter into the cylinder head.
Install the socket bolts with new sealing washers.
Tighten the socket bolts securely.

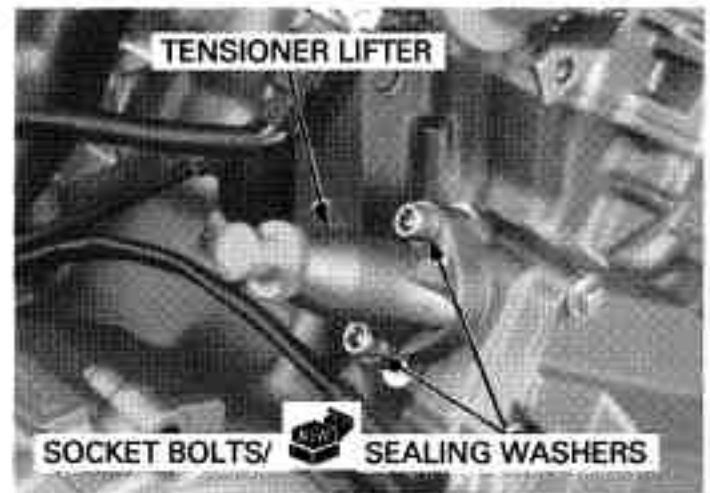

Remove the stopper tool.

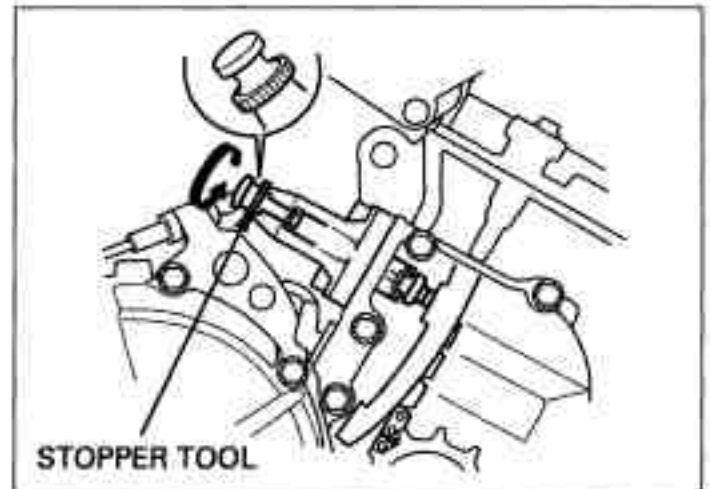

Install a new sealing washer and tighten the sealing bolt to the specified torque.

Install the removed parts in the reverse order of removal.

TORQUE: 10 N·m (1.0 kgf·m, 7 lbf·ft)

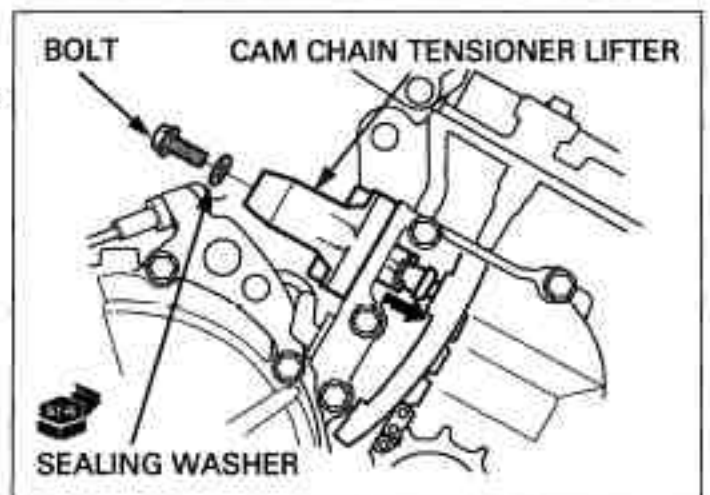

CYLINDER HEAD/VALVES

PAIR REED VALVE

REMOVAL

Disconnect the air suction (No.16) hose from the PAIR reed valve cover.

Remove bolts and PAIR reed valve cover

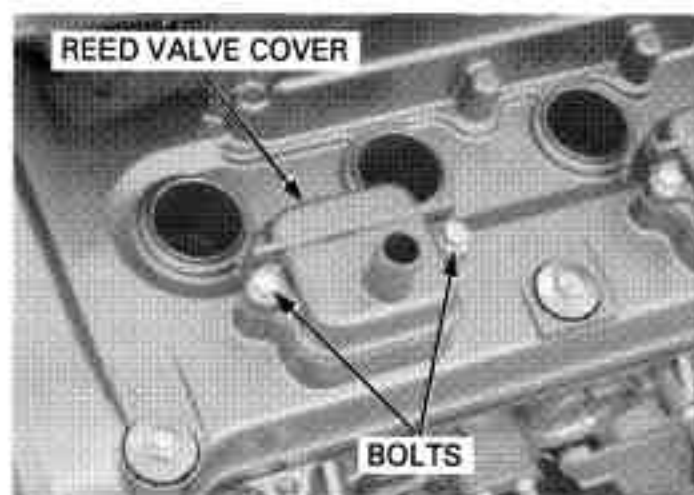

Check the PAIR reed valve for wear or damage, replace if necessary.

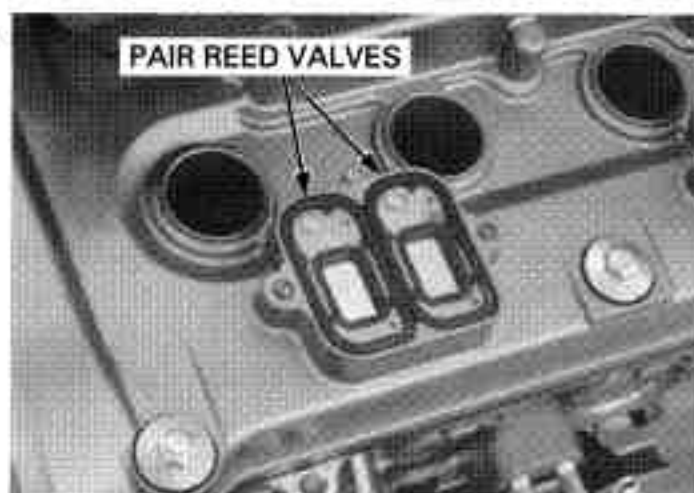

Remove the port plates from the cylinder head cover.

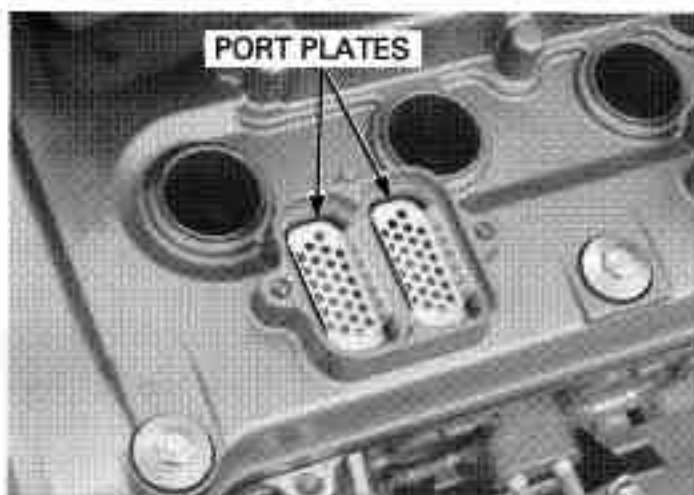

INSTALLATION

Install the port plates to the cylinder head cover.

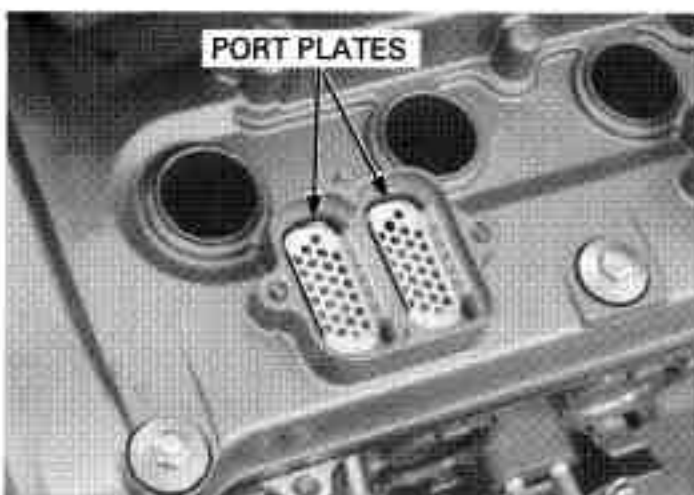

Install the PAIR reed valves to the cylinder head cover.

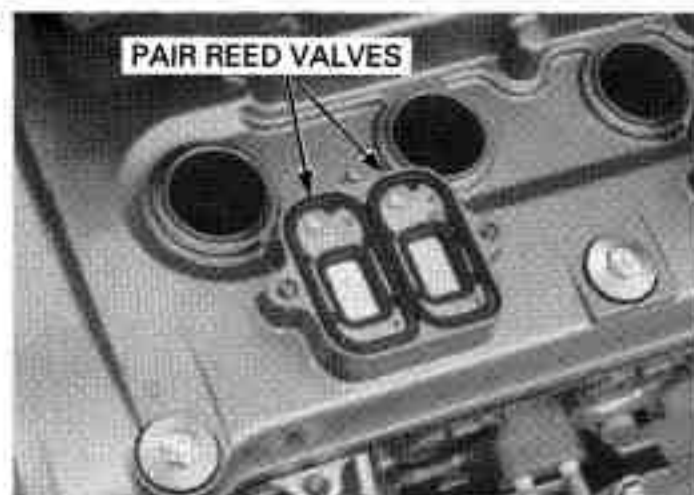

Install the PAIR reed valve cover.
Install and tighten the bolts to the specified torque.

TORQUE: 13 N·m (1.3 kgf·m, 9 lbf·ft)

Connect the air suction (No.16) hose to the PAIR reed valve cover.

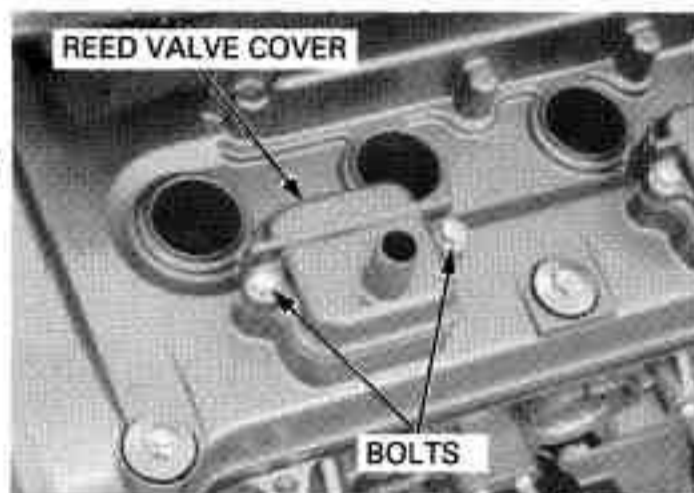

10. CLUTCH/GEARSHIFT LINKAGE

COMPONENT LOCATION.....	10-2	CLUTCH.....	10-7
SERVICE INFORMATION	10-3	GEARSHIFT LINKAGE.....	10-15
TROUBLESHOOTING	10-5	RIGHT CRANKCASE COVER INSTALLATION.....	10-18
RIGHT CRANKCASE COVER REMOVAL....	10-6		

CLUTCH/GEARSHIFT LINKAGE

COMPONENT LOCATION

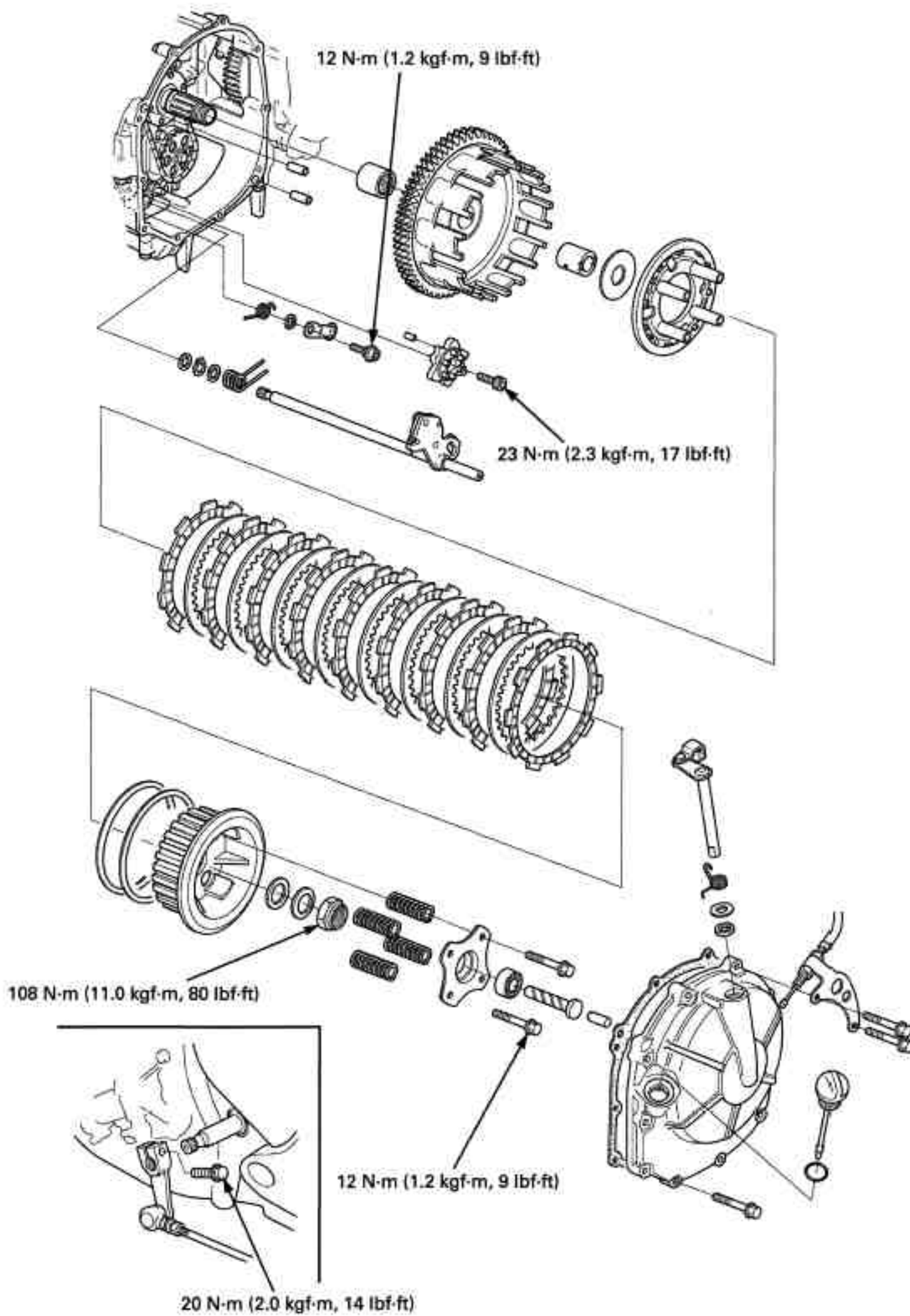

SERVICE INFORMATION

GENERAL

- This section covers service of the clutch, gearshift linkage, shift drum and shift forks. All service can be done with the engine installed in the frame.
- Transmission oil viscosity and level have an effect on clutch disengagement. When the clutch does not disengage or the motorcycle creeps with clutch disengaged, inspect the transmission oil level before servicing the clutch system.

SPECIFICATIONS

Unit: mm (in)





ITEM		STANDARD	SERVICE LIMIT
Clutch lever free play		10 – 20 (3/8 – 13/16)	–
Clutch	Spring free length	48.9 (1.93)	47.5 (1.87)
	Disc thickness	2.92 – 3.08 (0.115 – 0.121)	2.6 (0.10)
	Plate warp	–	0.30 (0.012)
Clutch outer guide	I.D.	21.994 – 22.007 (0.8659 – 0.8664)	22.017 (0.8668)
	O.D.	34.975 – 34.991 (1.3770 – 1.3776)	34.965 (1.3766)
Mainshaft O.D. at clutch outer guide		21.980 – 21.993 (0.8654 – 0.8659)	21.95 (0.864)

TORQUE VALUES

Clutch center lock nut	108 N·m (11.0 kgf·m, 80 lbf·ft)	Apply oil to the thread Stake the nut
Clutch spring bolt	12 N·m (1.2 kgf·m, 9 lbf·ft)	
Shift drum center socket bolt	23 N·m (2.3 kgf·m, 17 lbf·ft)	Apply a locking agent to the threads
Shift drum stopper arm pivot bolt	12 N·m (1.2 kgf·m, 9 lbf·ft)	
Gearshift spindle return spring pin	23 N·m (2.3 kgf·m, 17 lbf·ft)	
Gearshift pedal link bolt (gearshift pedal side)	26 N·m (2.7 kgf·m, 20 lbf·ft)	
Gearshift pedal link bolt (gearshift spindle side)	20 N·m (2.0 kgf·m, 14 lbf·ft)	

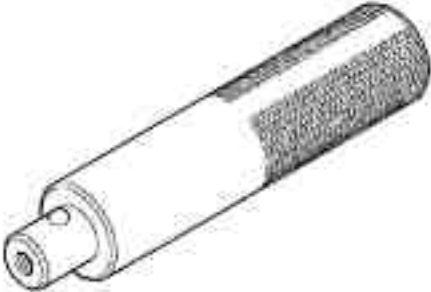
CLUTCH/GEARSHIFT LINKAGE

TOOLS

<p>Clutch center holder 07JMB-MN50301</p>  <p>or Holder plate 07HGB-001010B or 07HGB-001010A and Holder collar "A" 07HGB-001020B or 07HGB-001010A</p>	<p>Driver 07749-0010000</p> 	<p>Attachment, 37 X 40 mm 07746-0010200</p> 
<p>Attachment, 42 X 47 mm 07746-0010300</p> 	<p>Pilot, 35 mm 07746-0040800</p> 	

TROUBLESHOOTING**Clutch lever too hard to pull in**

- Damaged, kinked or dirty clutch cable
- Damaged clutch lifter mechanism
- Faulty clutch lifter bearing
- Clutch lifter piece installed improperly

Clutch slips when accelerating

- Incorrect clutch adjustment
- Worn clutch disc
- Weak clutch springs
- Transmission oil mixed with molybdenum or graphite additive

Clutch will not disengage or motorcycle creeps with clutch disengaged

- Incorrect clutch adjustment
- Clutch plate warped
- Loose clutch lock nut
- Oil level too high
- Improper oil viscosity
- Damaged clutch lifter mechanism
- Clutch lifter piece installed improperly

Hard to shift

- Incorrect clutch adjustment
- Improper oil viscosity
- Bent shift fork
- Bent shift fork shaft
- Bent fork claw
- Damaged shift drum cam groove
- Loose stopper plate bolt
- Damaged stopper plate and pin
- Damaged gearshift spindle

Transmission jumps out of gear

- Worn shift drum stopper arm
- Weak or broken shift arm return spring
- Loose stopper plate bolt
- Bent shift fork shaft
- Damaged shift drum cam groove
- Damaged or bent shift forks
- Worn gear engagement dogs or slots

Gearshift pedal will not return

- Weak or broken gearshift spindle return spring
- Bent gearshift spindle

RIGHT CRANKCASE COVER REMOVAL

Drain the engine oil (page 4-15).

Remove the bolts and clutch cable holder, then disconnect the clutch cable from the clutch arm.
Remove the bolts and right crankcase cover.

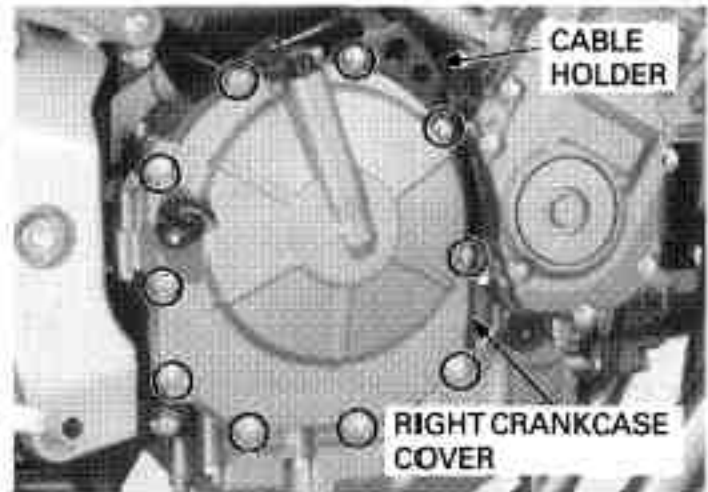

Remove the dowel pins and gasket.

Clean any gasket off from the right crankcase cover mating surfaces.

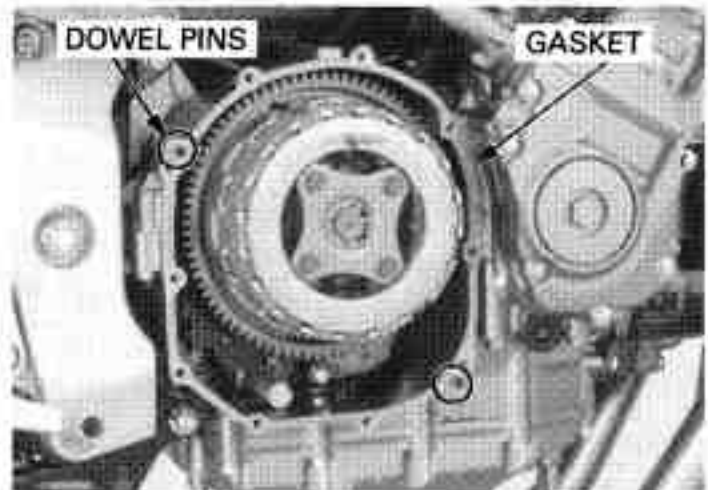

CLUTCH LIFTER LEVER

Remove the clutch lifter piece.
Remove the clutch lifter arm, return spring and washer from the right crankcase cover.

Check the lifter arm spindle for wear, damage or bending.
Check the return spring for fatigue or damage.

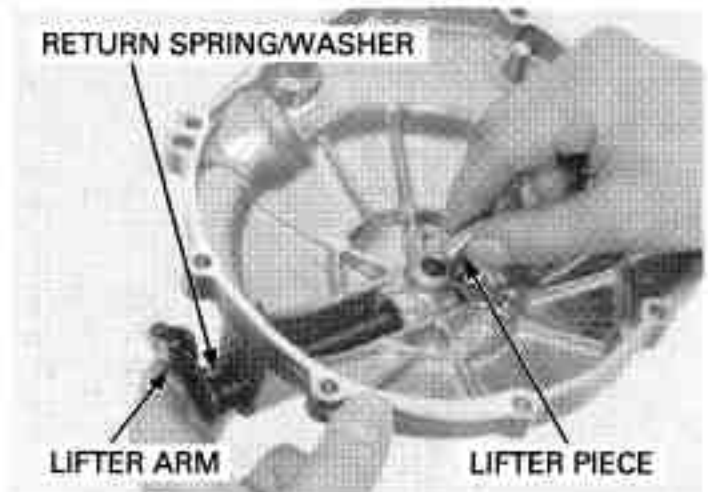

Check the needle bearings for wear, damage or loose fit.
Check the oil seal for fatigue or damage.

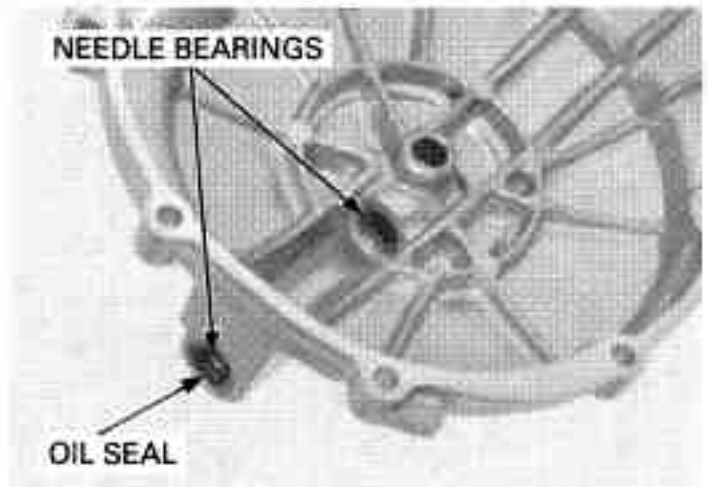

CLUTCH

REMOVAL

Remove the right crankcase cover (page 10-6).

Remove the clutch lifter rod from the lifter bearing.

Remove the clutch spring bolts, springs and lifter plate.

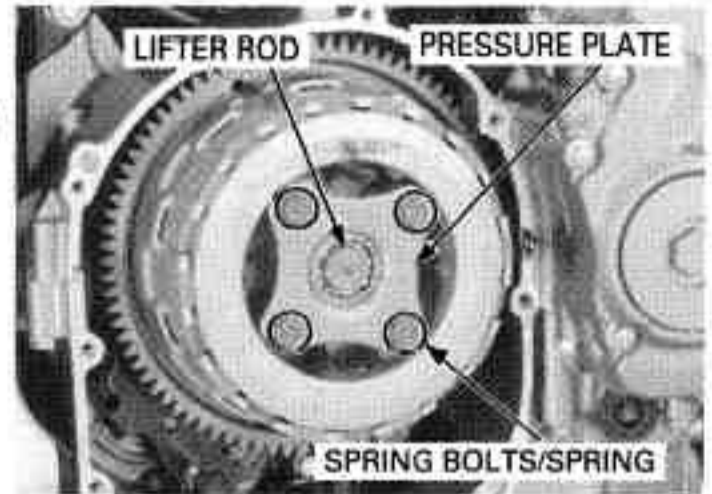

Unstake the clutch center lock nut.

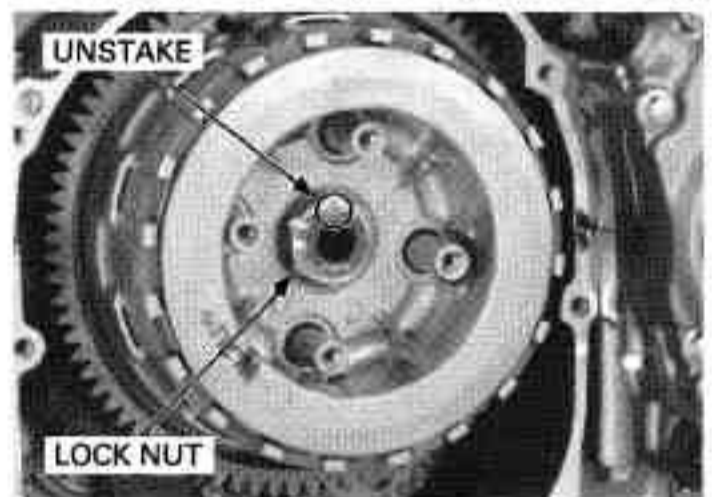

Set the clutch center holder onto the clutch center. Install and finger tighten the four lifter plate bolts.

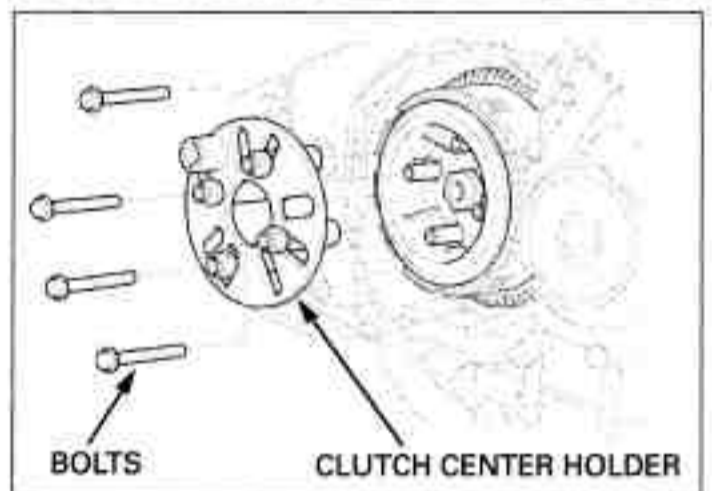

Hold the clutch center holder and remove the lock nut.

TOOL:

Clutch center holder 07JMB-MN50301 or
Holder plate 07HGB-001010B or

Holder collar "A"

07HGB-001010A and
07HGB-001020B or
07HGB-001020A

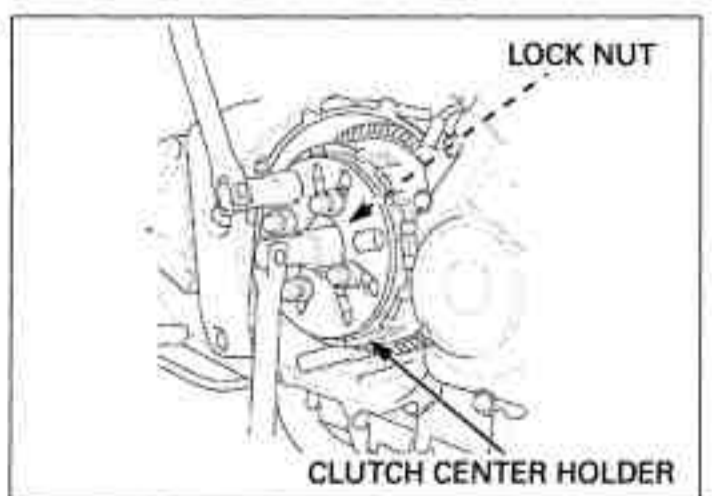

CLUTCH/GEARSHIFT LINKAGE

Remove the lock washer and thrust washer.

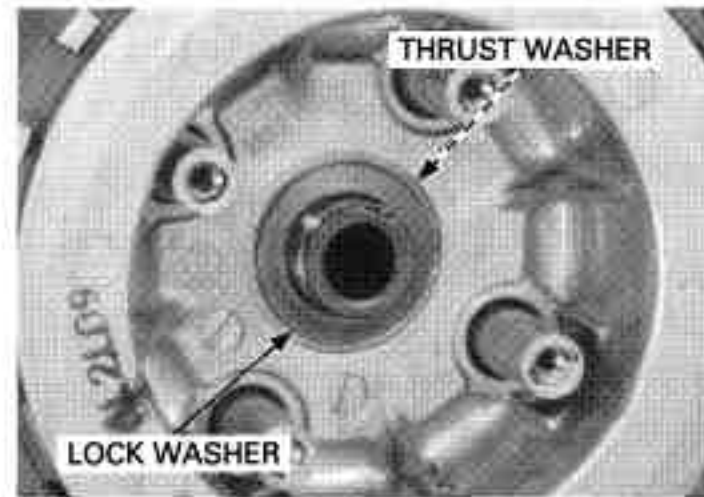

Remove the following:

- Clutch center
- Judder spring
- Spring seat
- Clutch disc B
- Eight clutch plate
- Eight clutch discs

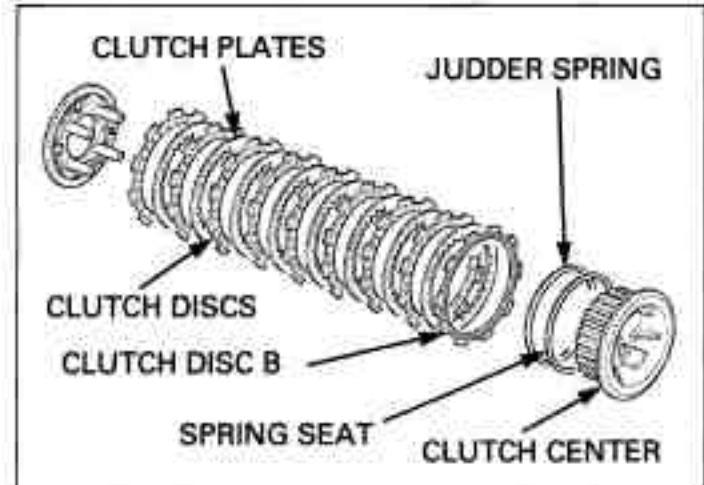

Remove the pressure plate and washer.

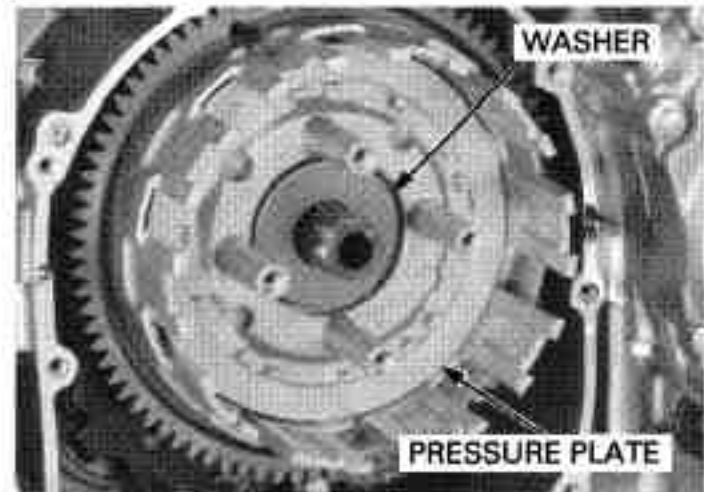

Insert a 5 mm pin (or suitable tool) into the holes in the primary driven gear and sub-gear to align the gear teeth.

Pull the clutch outer guide out by pinching the ribs on the clutch outer guide and sliding the guide forward.

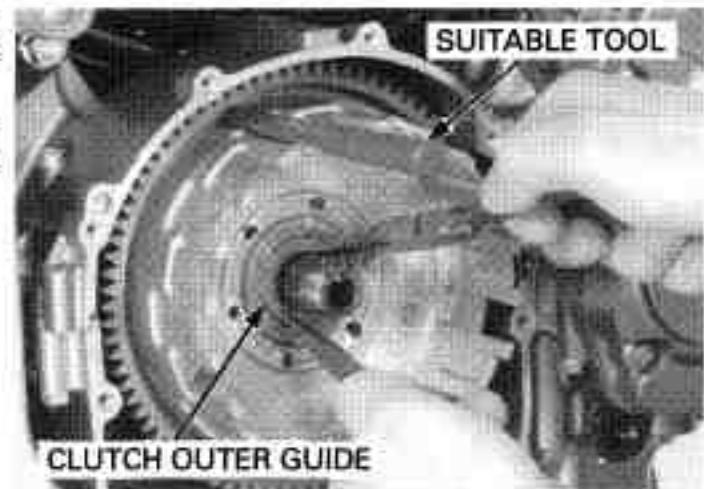

Remove the clutch outer from the mainshaft by positioning the projections of the crankcase between the teeth of the primary driven gears.

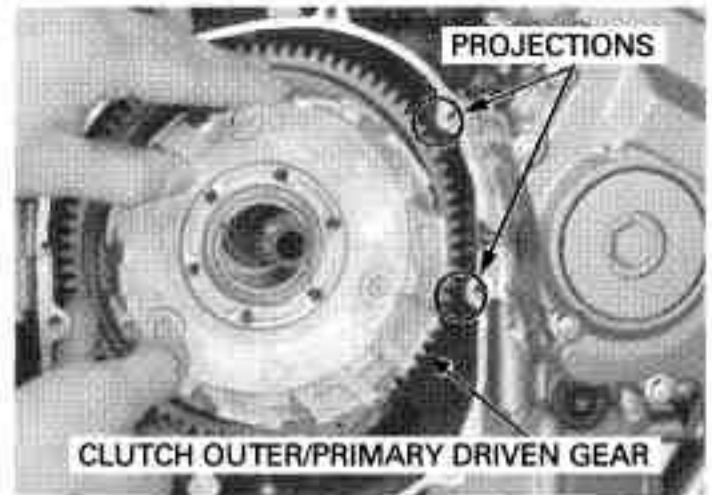

INSPECTION

Clutch lifter bearing

Turn the inner race of the lifter bearing with your finger. The bearing should turn smoothly and quietly without excessive play.

Replace if necessary.



Clutch spring

Replace the clutch spring as a set.

Measure the clutch spring free length.

SERVICE LIMIT: 475 mm (1.87 in)

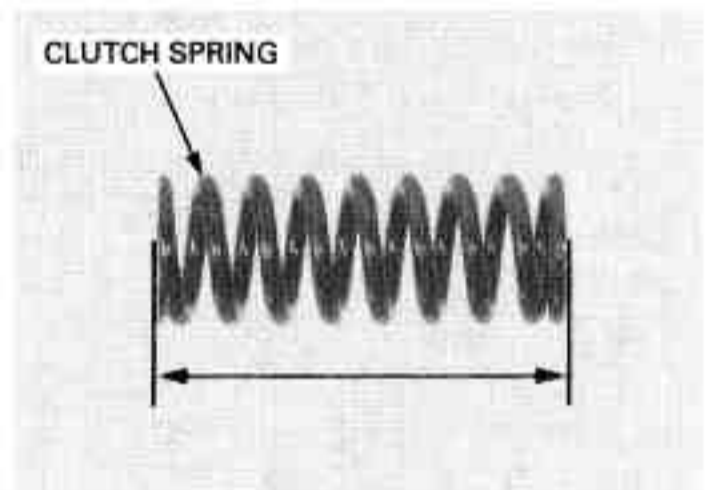

Clutch center

Check the grooves of the clutch center for damage or wear caused by the clutch plates. Replace if necessary.

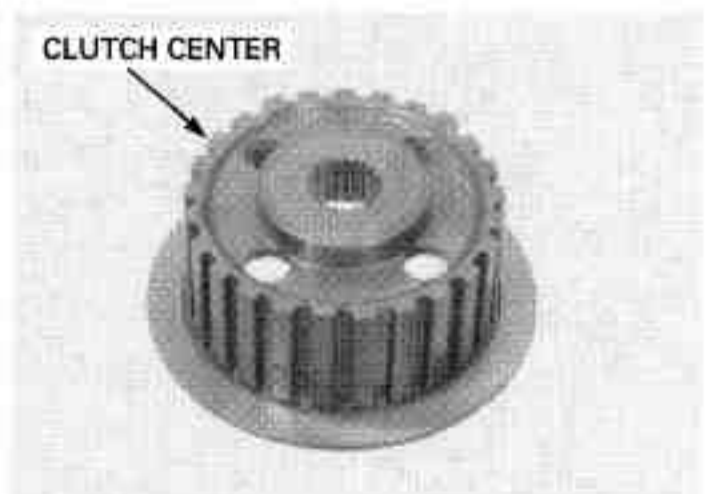

CLUTCH/GEARSHIFT LINKAGE

Clutch lifter rod

Check the clutch lifter rod for wear or damage.

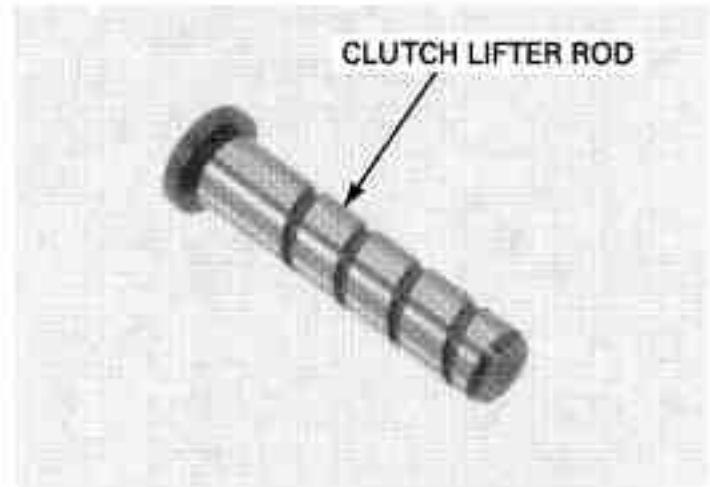

Clutch disc

Replace the clutch discs and plates as a set.

Replace the clutch discs if they show signs of scoring or discoloration.

Measure the disc thickness of each disc.

SERVICE LIMIT: 2.6 mm (0.10 in)

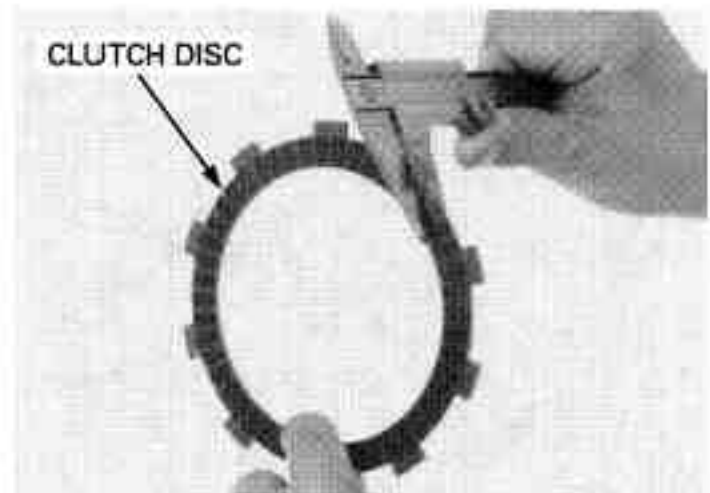

Clutch plate

Replace the clutch discs and plates as a set.

Check each disc plate for warpage on a surface plate using a feeler gauge.

SERVICE LIMIT: 0.30 mm (0.012 in)

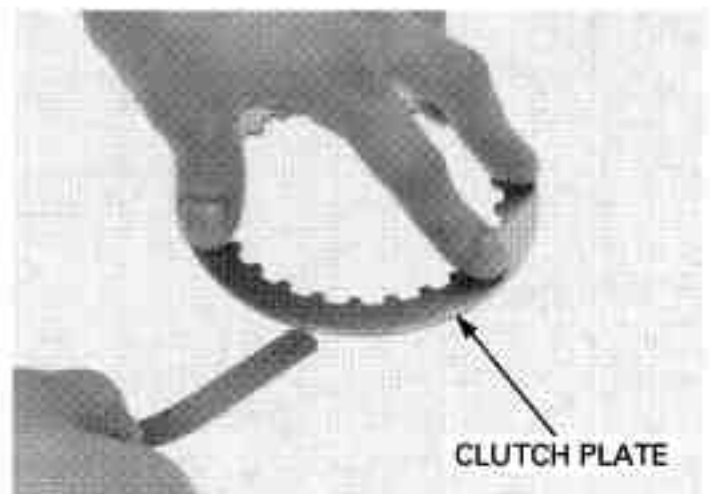

Clutch outer/clutch outer guide

Check the slots of the clutch outer for damage or wear caused by the clutch discs.

Check the serrated teeth of the primary driven gear for wear or damage.

Check the needle bearing for wear or damage.

Replace if necessary.

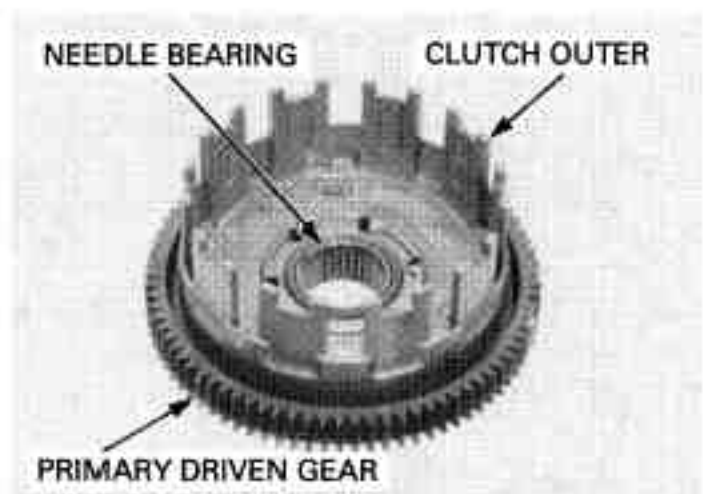

Measure the O.D. and I.D. of the clutch outer guide.

SERVICE LIMITS:

O.D.: 34.965 mm (1.3766 in)

I.D.: 22.017 mm (0.8668 in)

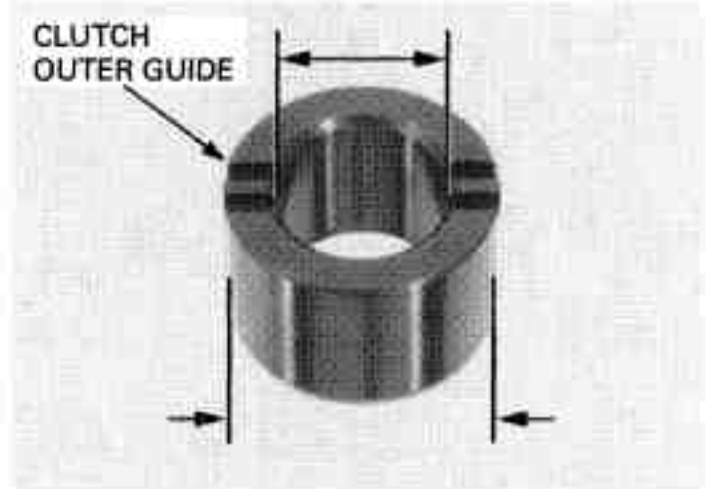

Mainshaft

Measure the mainshaft O.D. at clutch outer guide sliding surface.

SERVICE LIMIT: 21.95 mm (0.864 in)

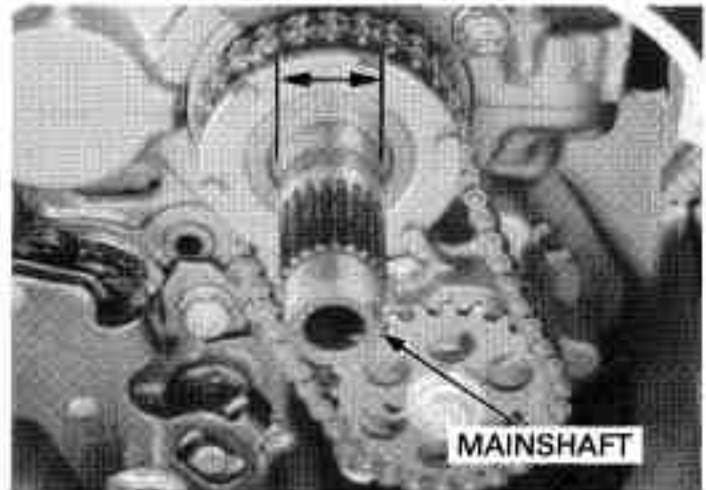

CLUTCH OUTER NEEDLE BEARING REPLACEMENT

Press the needle bearing out of the clutch outer using the special tools.

TOOLS:

Driver 07749-0010000

Attachment, 37 X 40 mm 07746-0010200

Pilot, 35 mm 07746-0040800

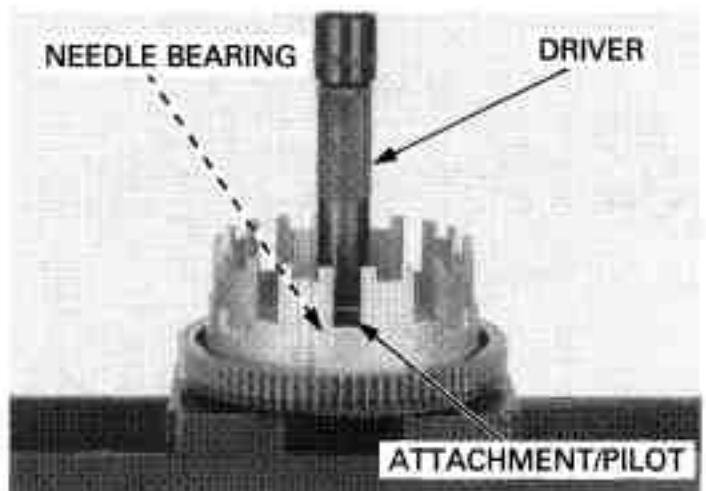

Press a new needle bearing into the clutch outer so that the casing of the needle bearing is flush with the inner edge of the clutch outer.

TOOLS:

Driver 07749-0010000

Attachment, 42 X 47 mm 07746-0010300

Pilot, 35 mm 07746-0040800

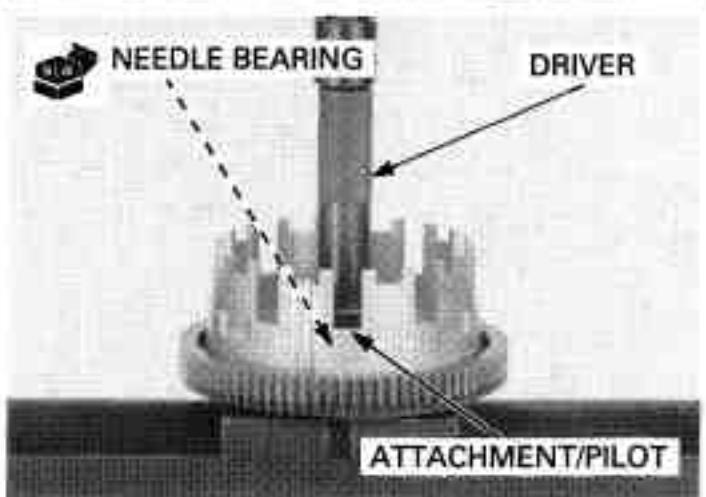

CLUTCH/GEARSHIFT LINKAGE

INSTALLATION

Apply molybdenum disulfide oil to the clutch outer needle bearing.

Install the clutch outer onto the mainshaft by positioning the projections of the crankcase between the teeth of the primary driven gears.

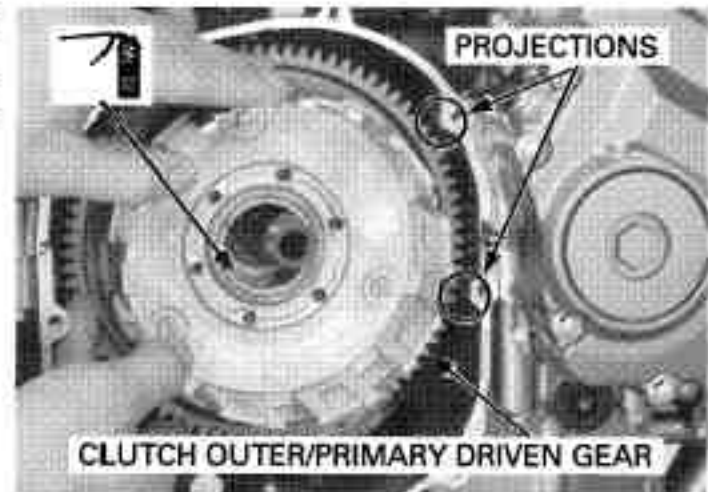

Align the primary drive gear and sub-gear teeth with a 5 mm pin (or suitable tool).

Apply molybdenum disulfide oil to the clutch outer guide.

Install the clutch outer guide with the ribbed side facing out.

Be sure the clutch outer sits securely onto the positioning tabs of the oil pump drive sprocket.

After installing the clutch outer guide, remove the 5 mm pin (or suitable tool) from the primary driven gear.

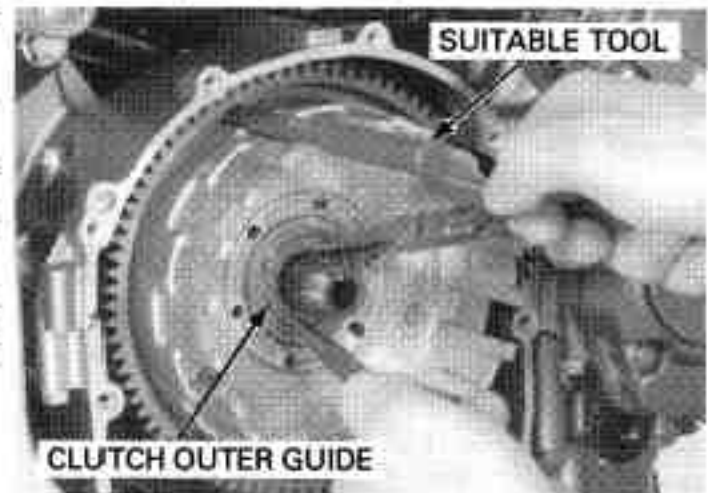

Install the thrust washer onto the mainshaft.

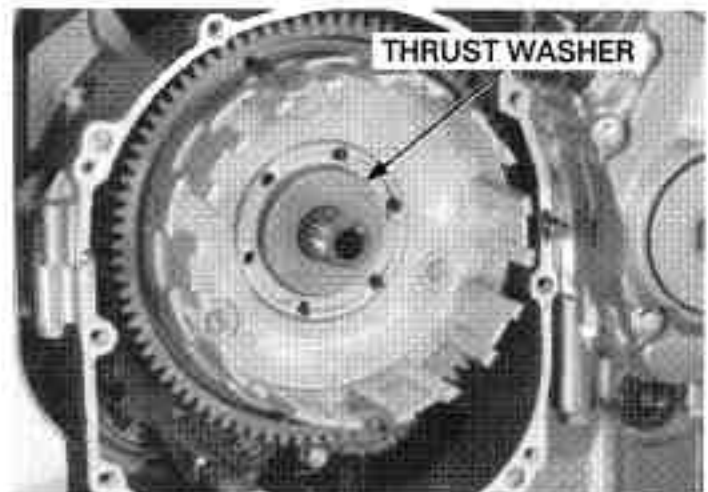

Coat the clutch discs and plates with clean engine oil.

Install the clutch disc B (larger I.D. disc) to the clutch center side.

Stack the clutch discs and plates alternately.

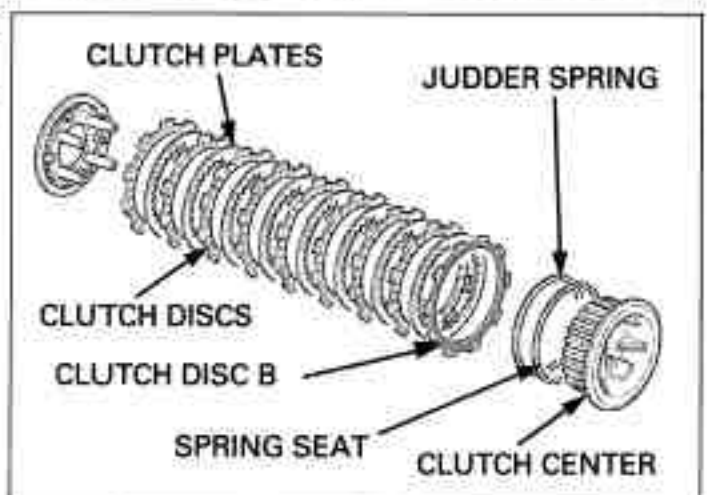

Install the spring seat and judder spring onto the clutch center as shown.

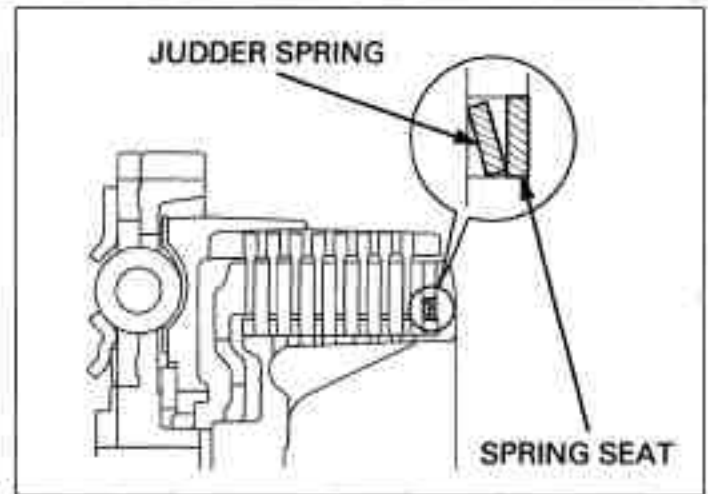

Install the pressure plate to the clutch center aligning the punch marks on the pressure plate and clutch center.

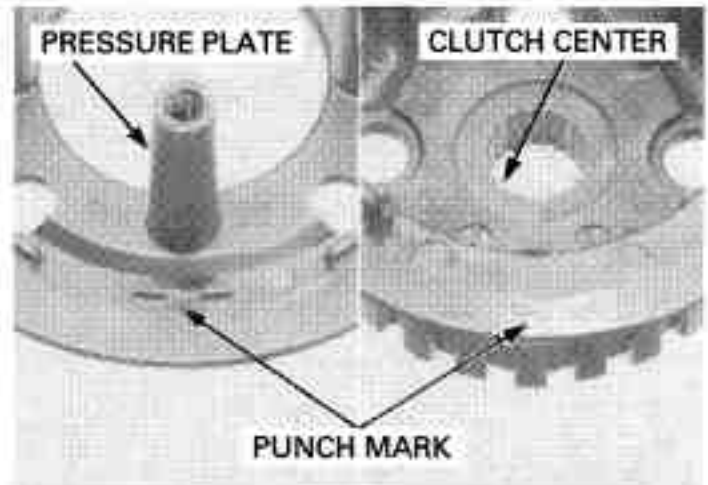

Install the clutch center assembly into the clutch outer.
Install the outer clutch disc (clutch disc B) in the shallow slot on the clutch outer.

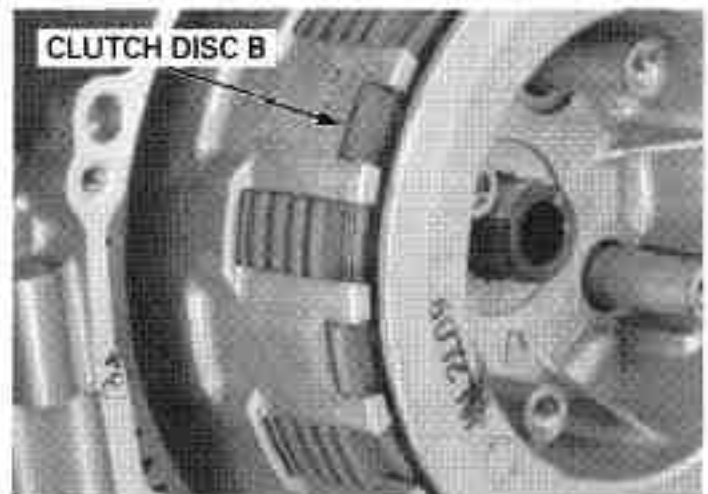

Install the thrust washer.
Install the lock washer with its "OUT SIDE" mark facing out.

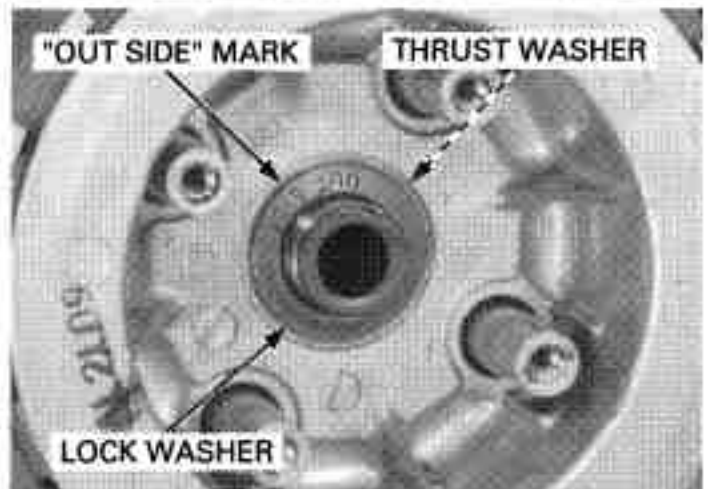

CLUTCH/GEARSHIFT LINKAGE

Apply engine oil to the threads and seating surface of a new clutch center lock nut and install it.

Set the clutch center holder onto the clutch center.

TOOL:

Clutch center holder 07JMB-MN50301 or
Holder plate 07HGB-001010B or
07HGB-001010A and

Holder collar "A" 07HGB-001020B or
07HGB-001020A

Install and finger tighten the four lifter plate bolts.

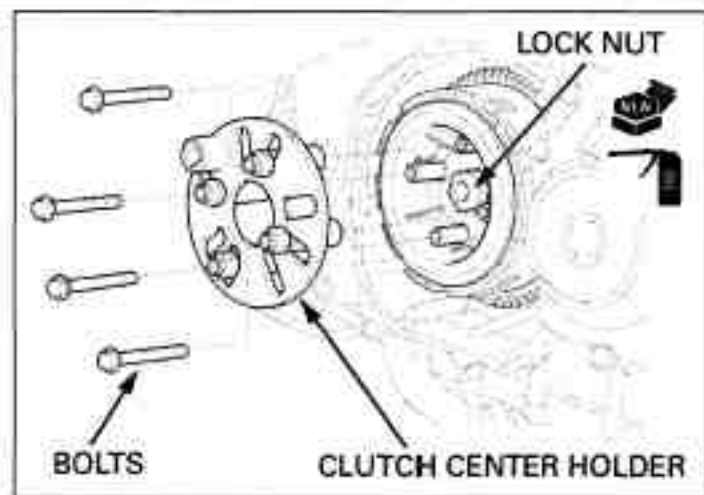

Hold the clutch center and tighten the clutch center lock nut.

TORQUE: 108 N·m (11.0 kgf·m, 80 lbf·ft)

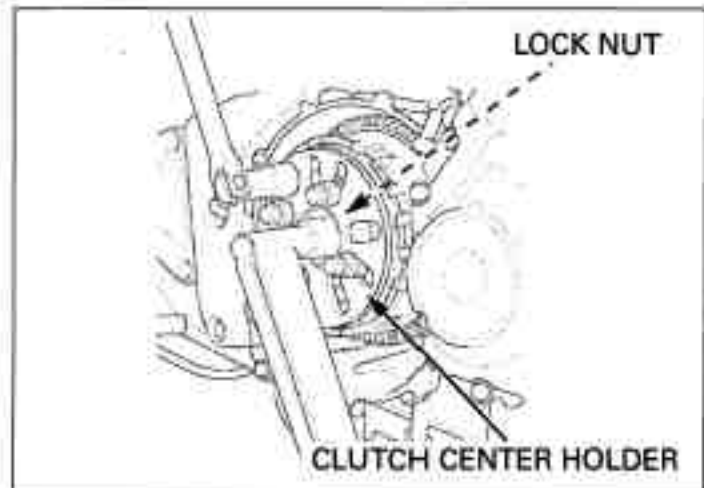

Be careful not to damage the mainshaft threads.

Stake lock nut into the mainshaft groove with a punch.

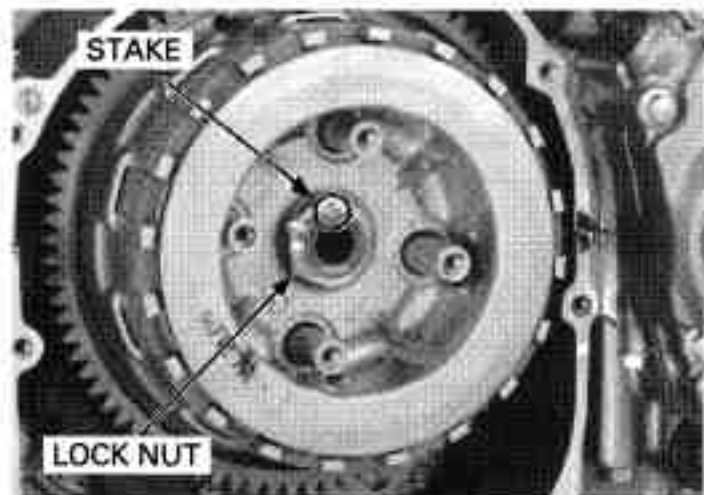

Install the clutch springs onto the pressure plate bosses.

Install the clutch lifter plate and lifter rod.

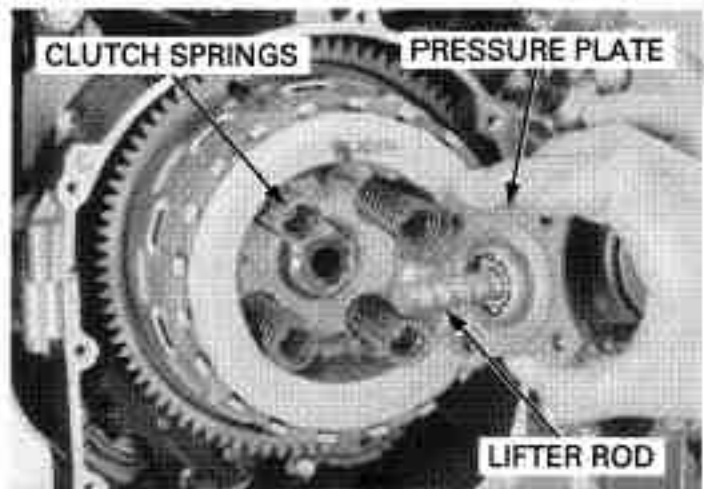

Install and tighten the bolts in a crisscross pattern in 2 - 3 steps, then tighten the bolts to the specified torque.

TORQUE: 12 N·m (1.2 kgf·m, 9 lbf·ft)

Install the right crankcase cover (page 10-18).

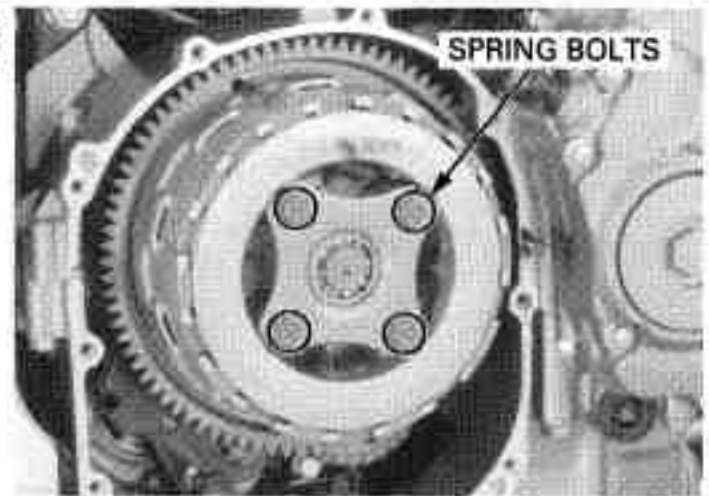

GEARSHIFT LINKAGE

GEARSHIFT LINKAGE REMOVAL

Remove the following:

- Right crankcase cover (page 10-6)
- Clutch assembly (page 10-7)

Remove the bolt and gearshift pedal link.

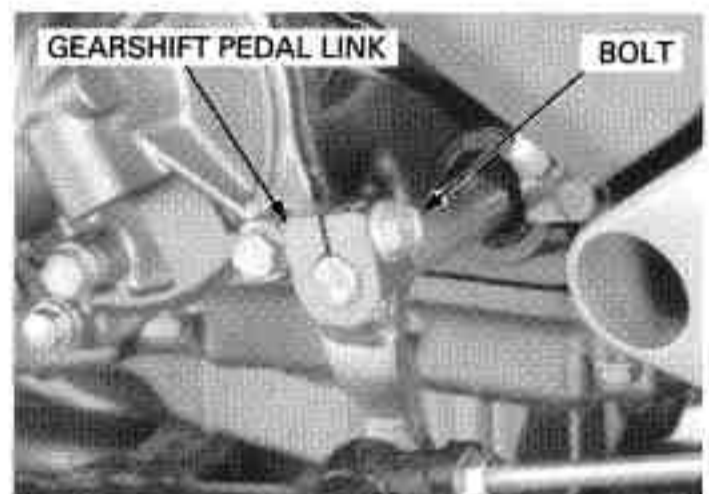

Pull the gearshift spindle assembly and thrust washer out of the crankcase.



Remove the shift drum center socket bolt, shift drum center and dowel pin.

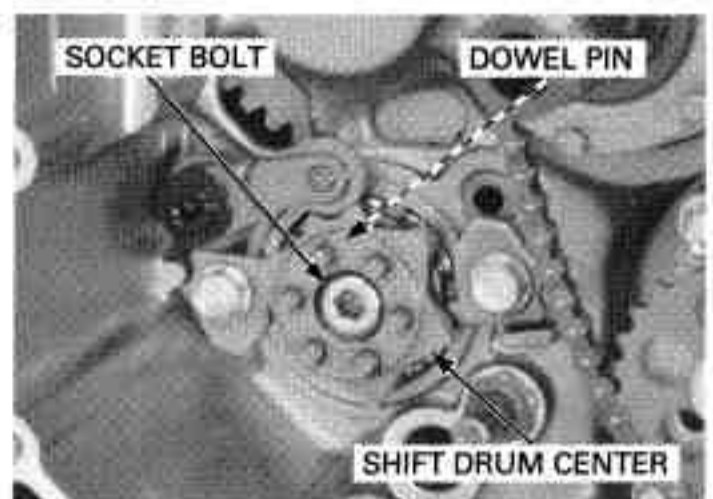

CLUTCH/GEARSHIFT LINKAGE

Remove the following:

- Stopper arm pivot bolt
- Stopper arm
- Return spring
- Washer

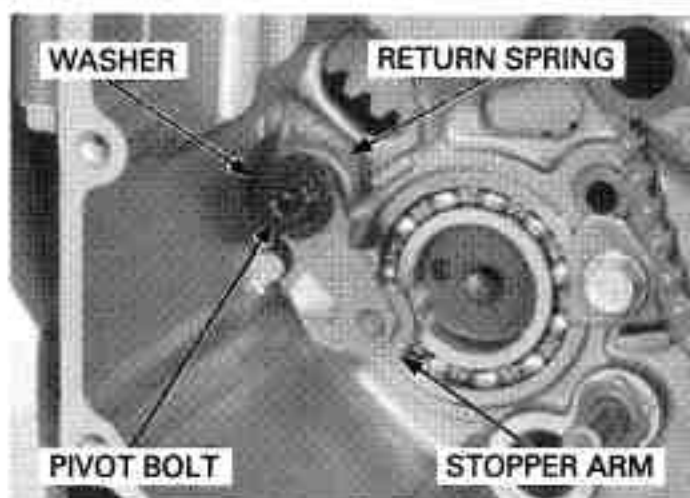

GEARSHIFT LINKAGE INSPECTION

Check the gearshift spindle for wear, damage or bending.
Check the return spring for fatigue or damage.

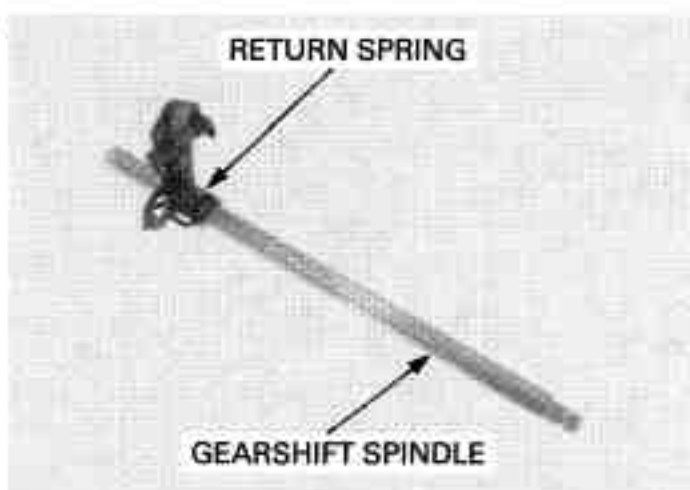

Check the needle bearing for wear or damage.
Check the oil seal for fatigue or damage.

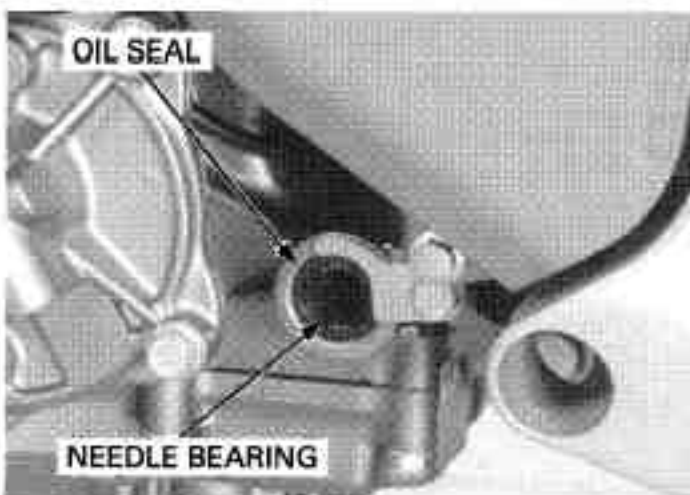

GEARSHIFT LINKAGE INSTALLATION

Install the following:

- Washer
- Return spring
- Stopper arm
- Stopper arm pivot bolt

Tighten the stopper arm pivot bolt to the specified torque.

TORQUE: 12 N·m (1.2 kgf·m, 9 lbf·ft)

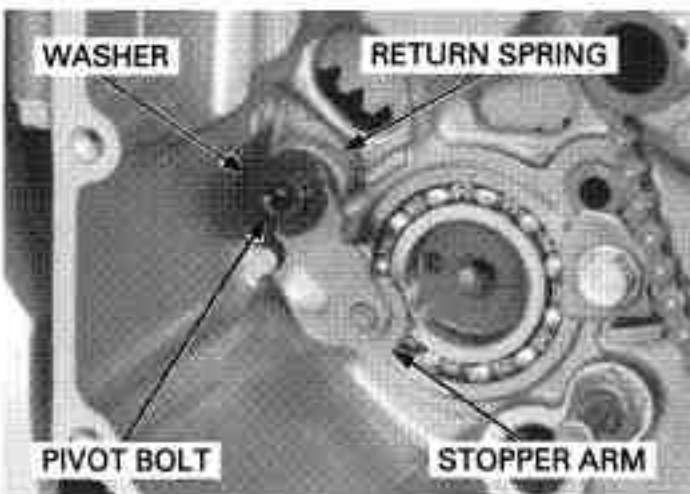

Align the dowel pin on the shift drum with the wide groove on the shift drum center.

Install the dowel pin onto the shift drum.

Install the shift drum center while holding the stopper arm using a screwdriver as shown.

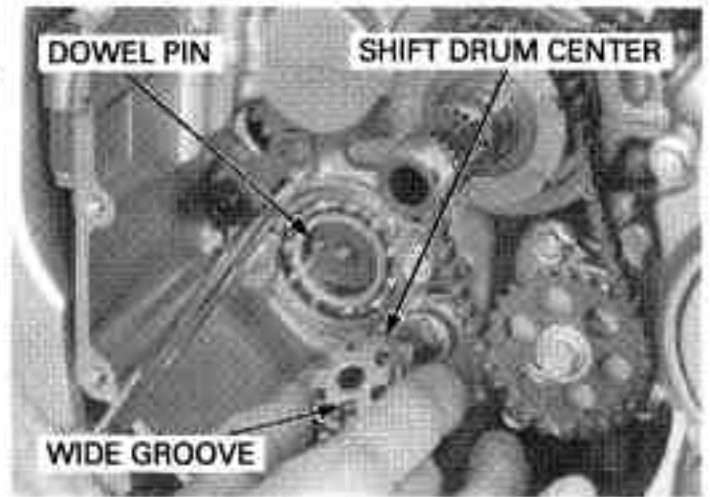

Apply a locking agent to the shift drum center socket bolt threads.

Install and tighten the socket bolt to the specified torque.

TORQUE: 23 N·m (2.3 kgf·m, 17 lbf·ft)

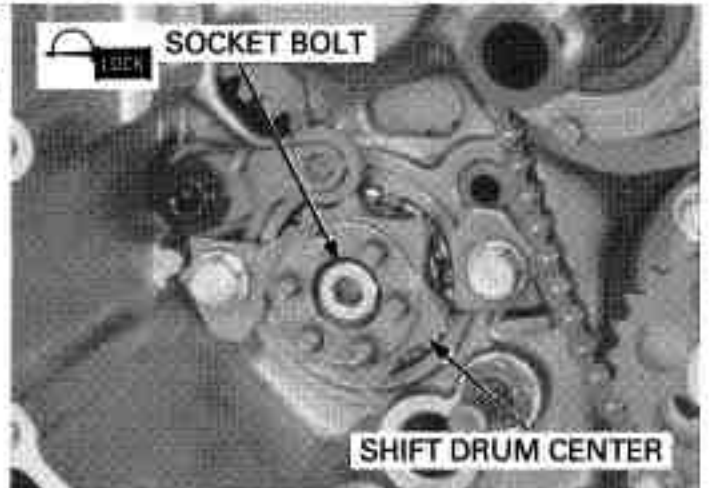

Install the thrust washer and gearshift spindle assembly into the crankcase while aligning the spring ends with the crankcase stopper pin.

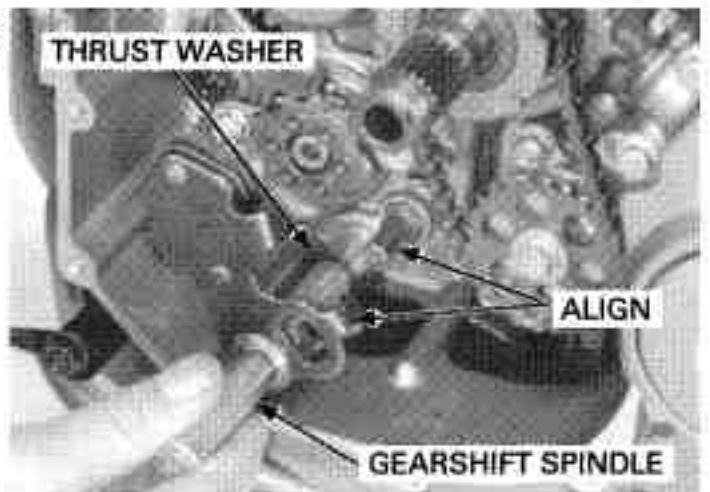

Install the gearshift pedal link aligning its slit with the punch mark on the gearshift spindle. Install and tighten the bolt to the specified torque:

TORQUE: 20 N·m (2.0 kgf·m, 14 lbf·ft)

Install the clutch assembly (page 10-12).

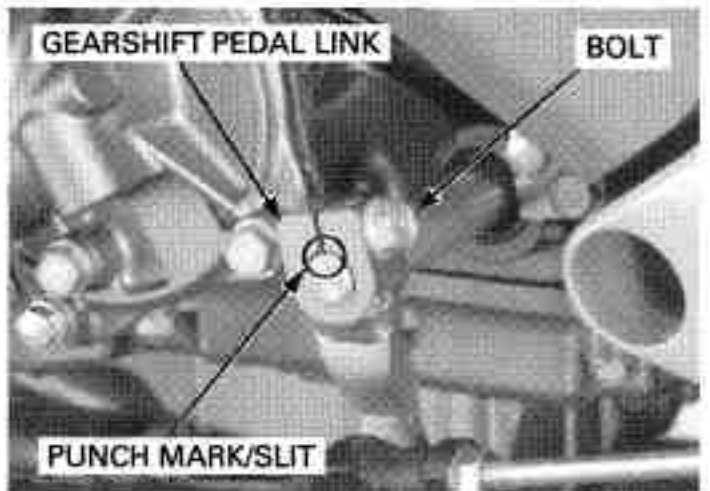

CLUTCH/GEARSHIFT LINKAGE

RIGHT CRANKCASE COVER INSTALLATION

Note the return spring direction and install the lifter arm with the spring and washer.
Apply grease to the clutch lifter piece and install it.

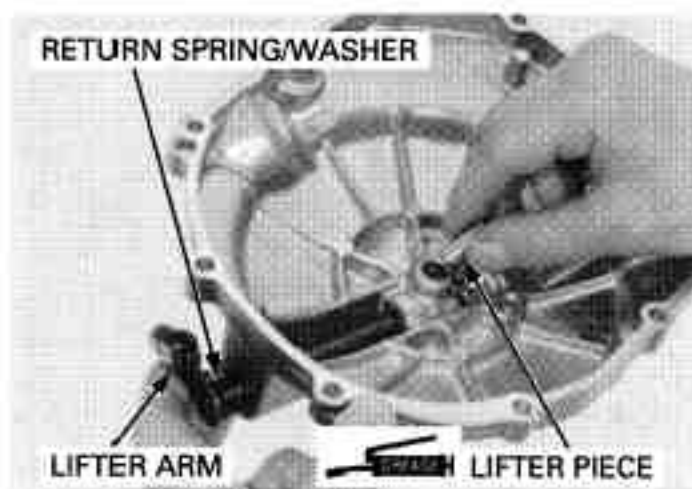

Apply a sealant to the mating surfaces of the crankcase as shown.

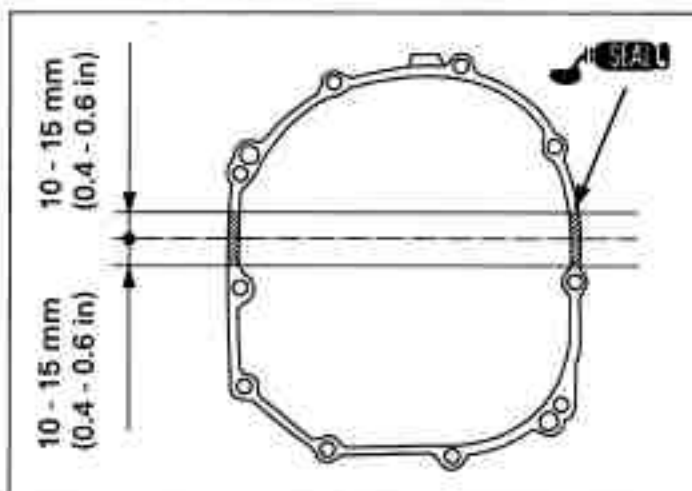

Install the two dowel pins and new gasket.

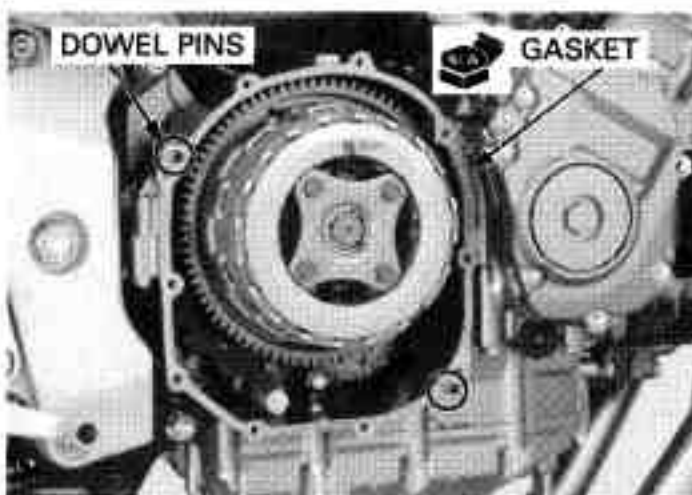

Install the right crankcase cover.
Connect the clutch cable to the clutch lifter arm and set the bracket, then install and tighten the bolts securely.

Pour the recommended engine oil (page 4-14).

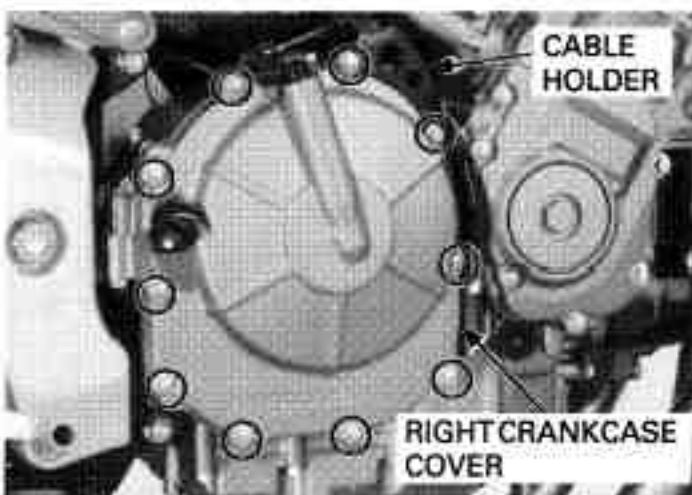

11. ALTERNATOR/STARTER CLUTCH

COMPONENT LOCATION.....	11-2	FLYWHEEL REMOVAL.....	11-6
SERVICE INFORMATION.....	11-3	STARTER CLUTCH.....	11-7
TROUBLESHOOTING.....	11-3	FLYWHEEL INSTALLATION.....	11-10
ALTERNATOR COVER REMOVAL.....	11-4	ALTERNATOR COVER INSTALLATION....	11-11
STATOR.....	11-5		

**ALTERNATOR/STARTER CLUTCH
COMPONENT LOCATION**

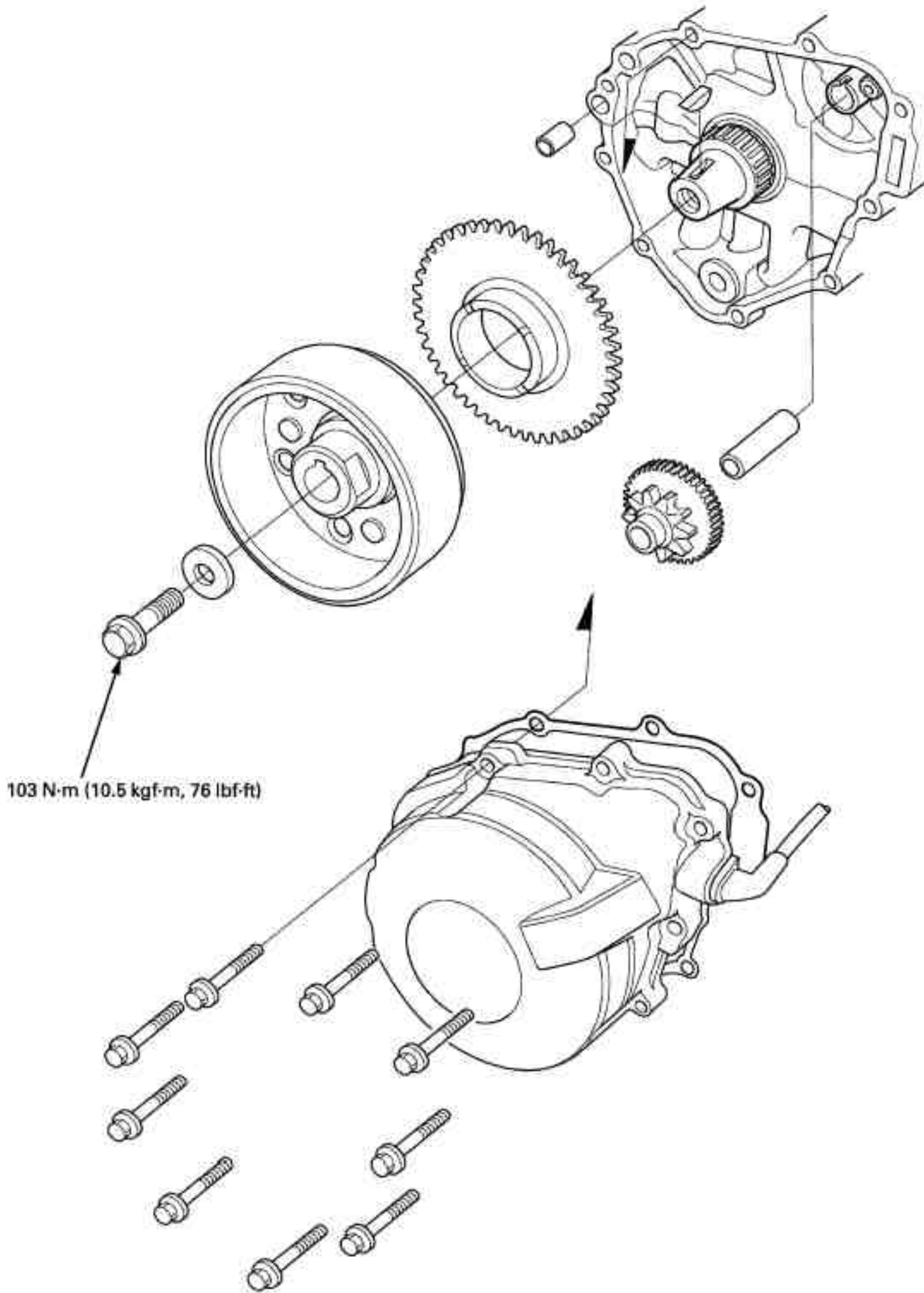

SERVICE INFORMATION

GENERAL

- This section covers service of the alternator stator, flywheel and starter clutch. All service can be done with the engine installed in the frame.
- Refer to procedures for alternator stator inspection (page 17-8).
- Refer to procedures for starter motor servicing (page 19-6).

SPECIFICATIONS

Unit: mm (in)

ITEM	STANDARD	SERVICE LIMIT
Starter driven gear boss O.D.	51.699 – 51.718 (2.0354 – 2.0361)	51.684 (2.0348)

TORQUE VALUES

Flywheel flange bolt	103 N·m (10.5 kgf·m, 76 lbf·ft)	Apply oil to the threads and flange surface
Stator mounting socket bolt	12 N·m (1.2 kgf·m, 9 lbf·ft)	
Alternator wire clamp socket bolt	10 N·m (1.0 kgf·m, 7 lbf·ft)	Apply a locking agent to the threads
Stater clutch outer torx bolt	16 N·m (1.6 kgf·m, 12 lbf·ft)	

TOOLS

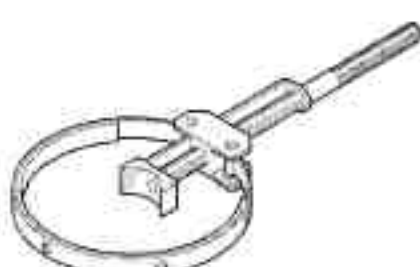
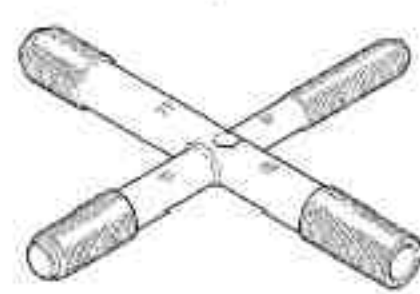
<p>Flywheel holder 07725-0040000</p>  <p>or equivalent commercially available in U.S.A.</p>	<p>Rotor puler 07733-0020001</p>  <p>or 07933-3950000 (U.S.A. only)</p>
--	---

TROUBLESHOOTING

Engine does not turn

- Faulty starter clutch
- Damaged reduction gear/shaft

STATOR**REMOVAL**

Remove the alternator wire grommet from the alternator cover.
Remove the socket bolt and alternator wire clamp.

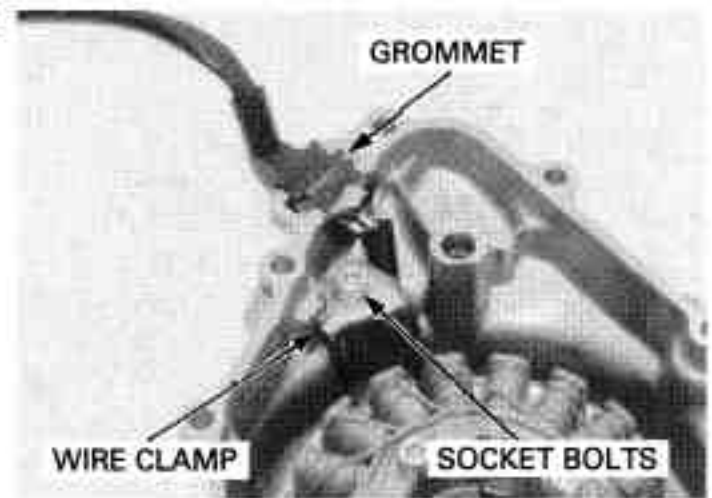

Remove the socket bolts and stator.

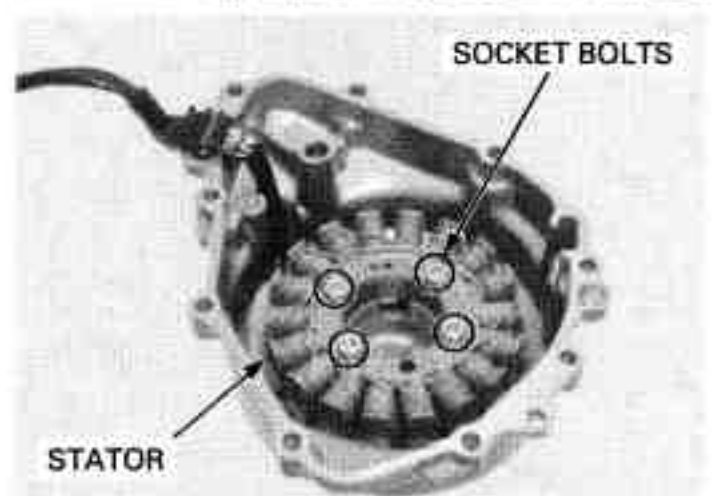
**INSTALLATION**

Install the stator into the alternator cover.
Install and tighten the stator mounting socket bolts to the specified torque.

TORQUE: 12 N·m (1.2 kgf·m, 9 lbf·ft)

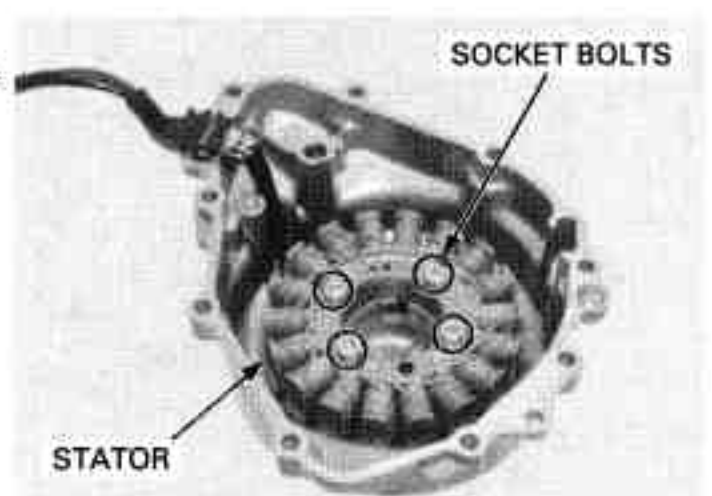

Apply sealant to the wire grommet, then install the wire grommet into the alternator groove securely.

Install the wire clamp and tighten the socket bolt to the specified torque.

TORQUE: 10 N·m (1.0 kgf·m, 7 lbf·ft)

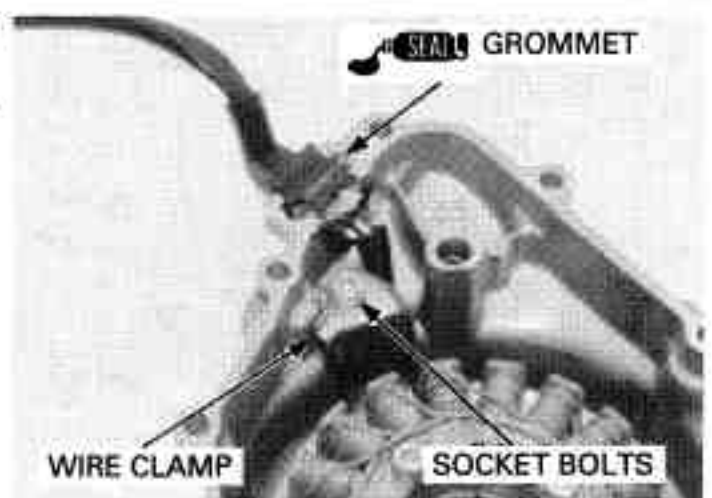

ALTERNATOR/STARTER CLUTCH

FLYWHEEL REMOVAL

Remove the alternator cover (page 11-4).

Hold the flywheel using the flywheel holder, then remove the flywheel bolt.

TOOL:

Flywheel holder **07725-0040000** or
equivalent commercially available
in U.S.A.

Remove the washer.

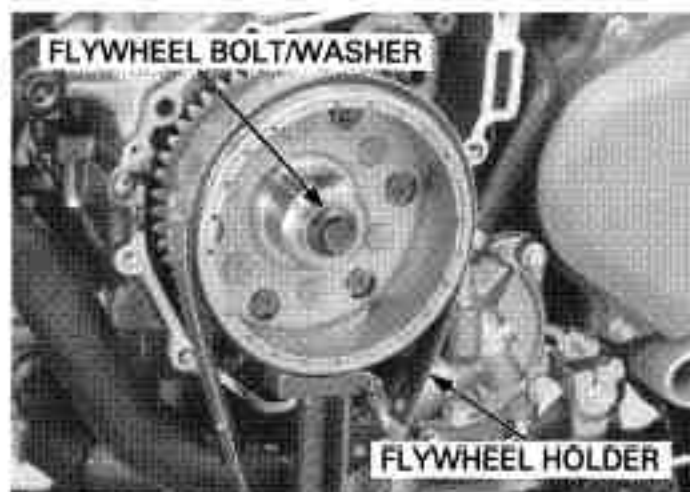

Remove the flywheel using the special tool.

TOOL:

Rotor puller **07733-0020001** or
07733-3950000 (U.S.A. only)

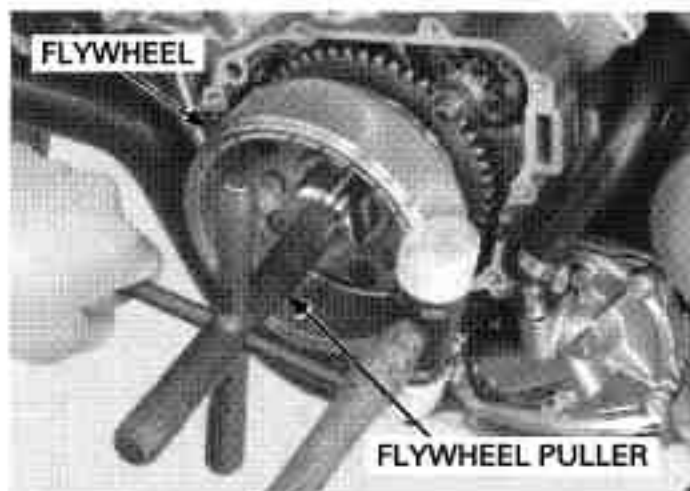

Remove the woodruff key.

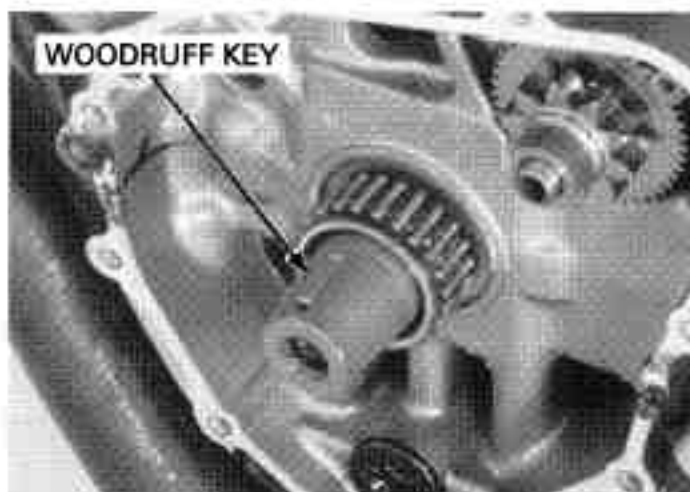

Remove the starter reduction gear shaft and reduction gear.

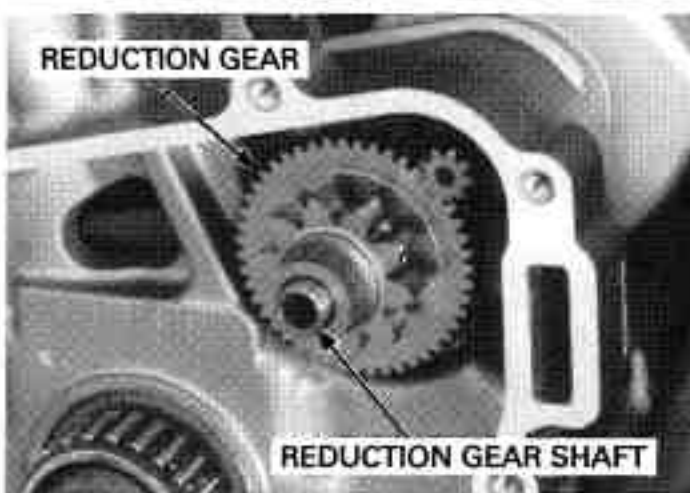

Check the starter reduction gear and shaft for wear or damage.

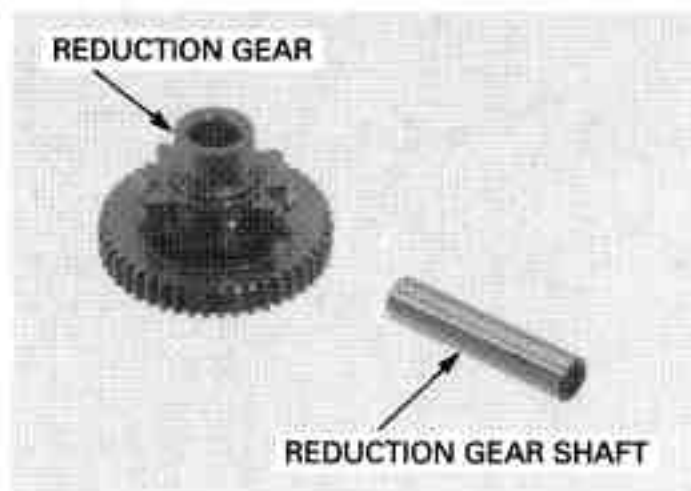

STARTER CLUTCH

INSPECTION

Check the operation of the one-way clutch by turning the driven gear. You should be able to turn the driven gear counterclockwise smoothly, but the gear should not turn clockwise.

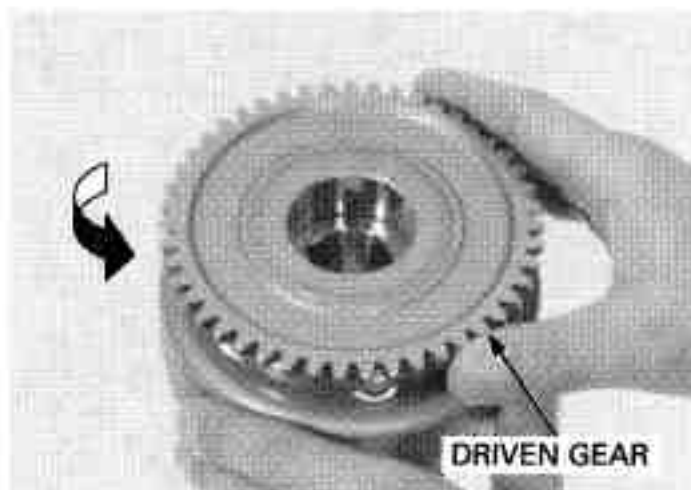

DISASSEMBLY

Remove the starter driven gear by turning it counterclockwise.

Hold the flywheel with a flywheel holder, and remove the starter clutch outer torx bolts.

TOOL:

Flywheel holder 07725-0040000 or equivalent commercially available in U.S.A.

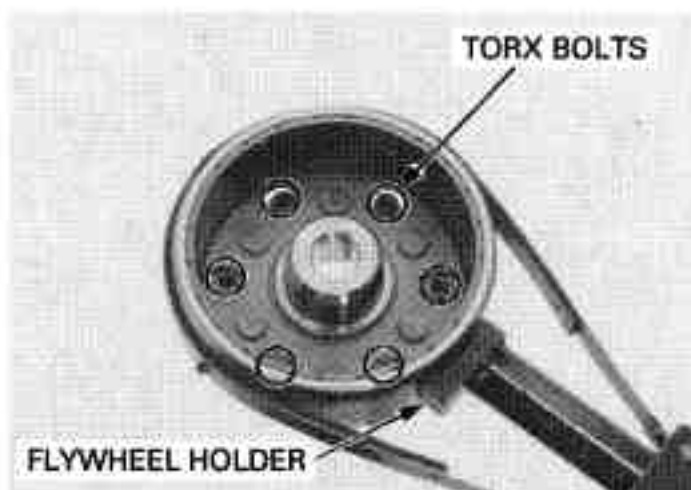

Remove the starter one-way clutch assembly from the flywheel.

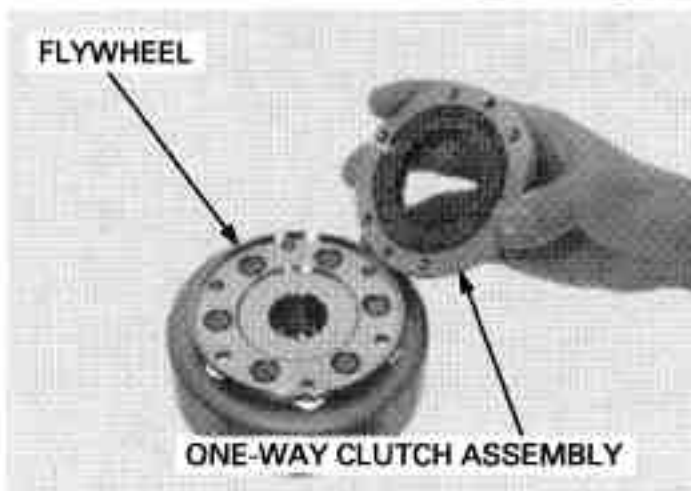

ALTERNATOR/STARTER CLUTCH

INSPECTION

Check the starter driven gear for abnormal wear or damage.

Measure the starter driven gear boss O.D.

SERVICE LIMIT: 51.684 mm (2.0348 in)

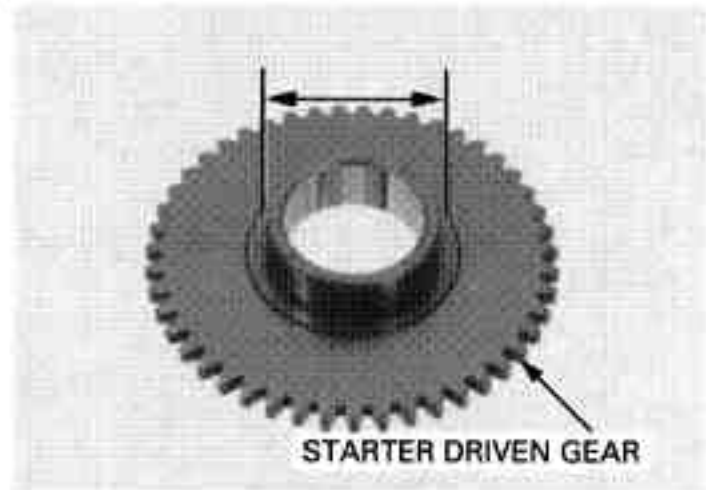

Check the one-way clutch sprag for wear, damage or irregular movement.
Replace if necessary.

Check the one-way clutch roller contact surface of the clutch outer for wear or damage.
Replace if necessary.

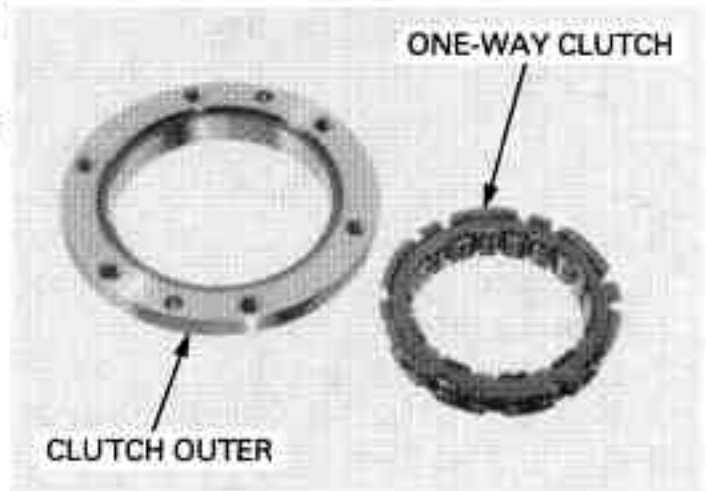

ASSEMBLY

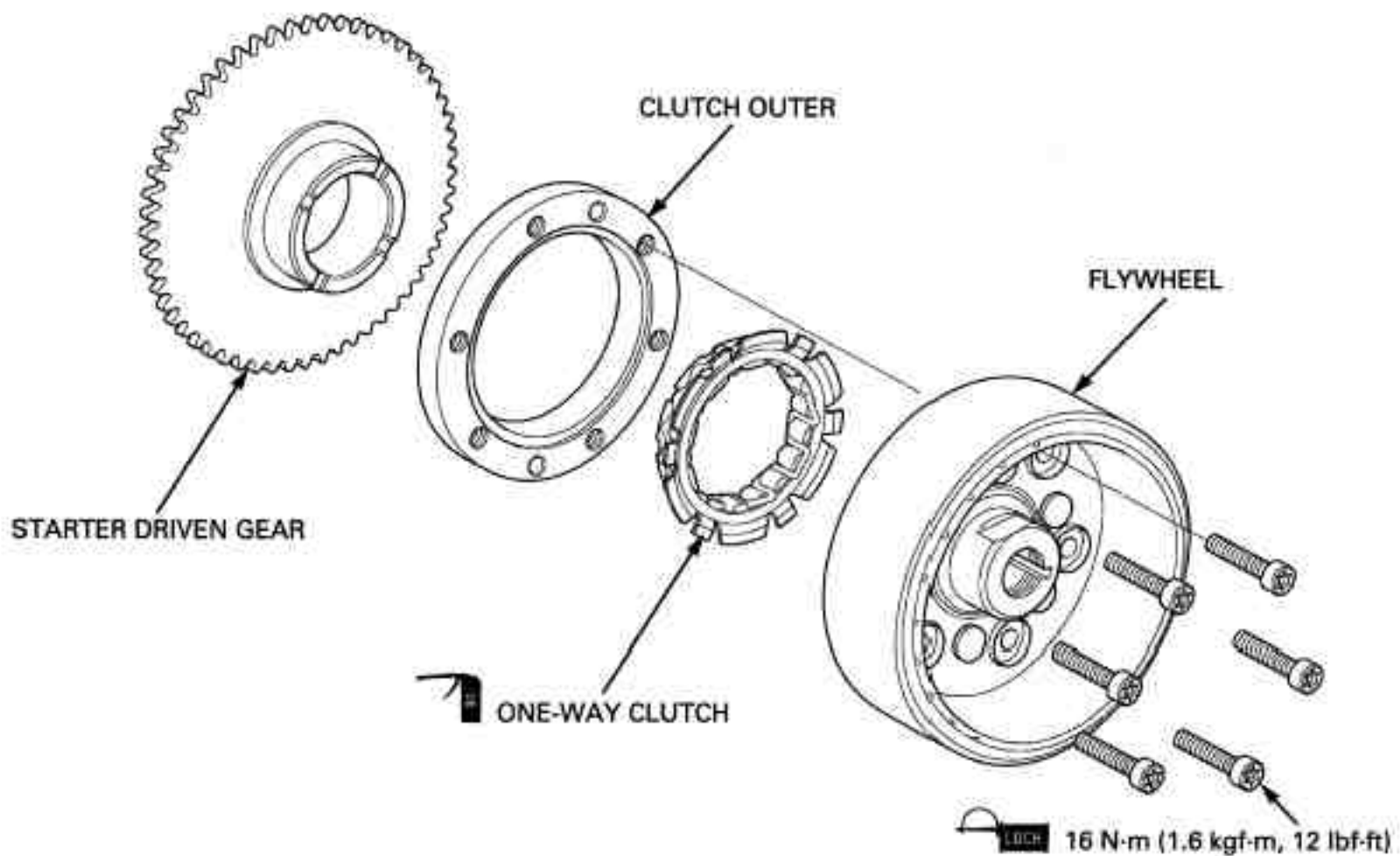

Apply engine oil to the one-way clutch contacting surfaces.
Install the one-way clutch into the starter clutch outer with the flange side facing the flywheel.

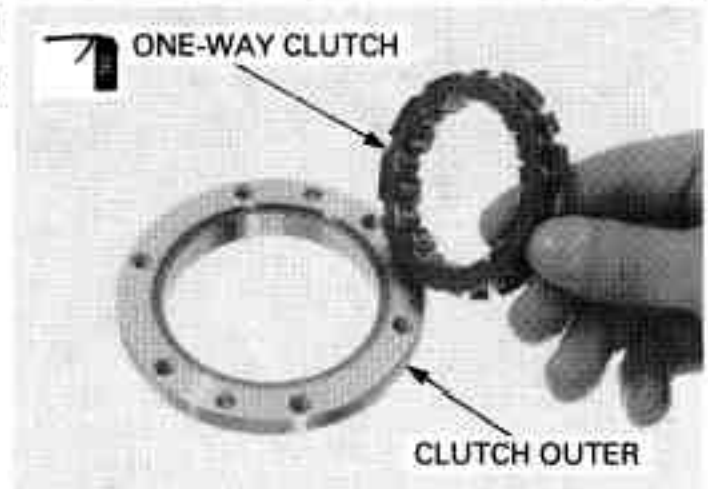

Install the starter one-way clutch assembly onto the flywheel.

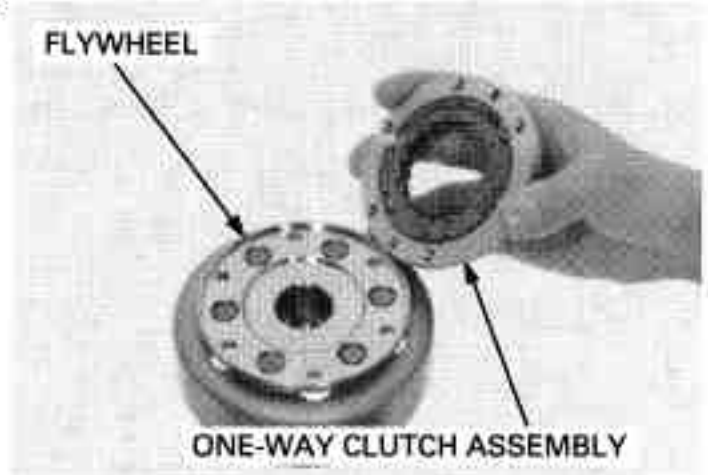

Apply a locking agent to the starter clutch outer torx bolt threads.
Hold the flywheel with a flywheel holder, and tighten the starter clutch outer torx bolts.

TOOL:

Flywheel holder 07725-0040000 or equivalent commercially available in U.S.A.

TORQUE: 16 N-m (1.6 kgf-m, 12 lbf-ft)

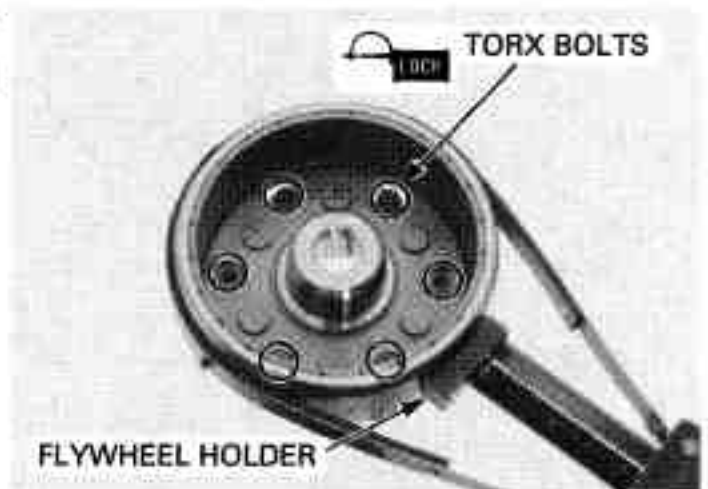

Install the starter driven gear into the one-way clutch while turning it counterclockwise.

Recheck the one-way clutch operation.
You should be able to turn the driven gear counterclockwise smoothly, but the gear should not turn clockwise.

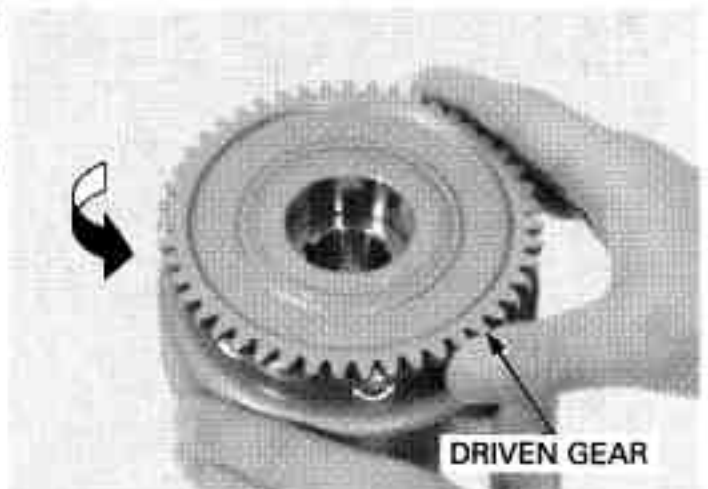

ALTERNATOR/STARTER CLUTCH

FLYWHEEL INSTALLATION

Apply molybdenum oil solution to the starter reduction gear shaft.
Install the starter idle gear and shaft onto the crankcase.

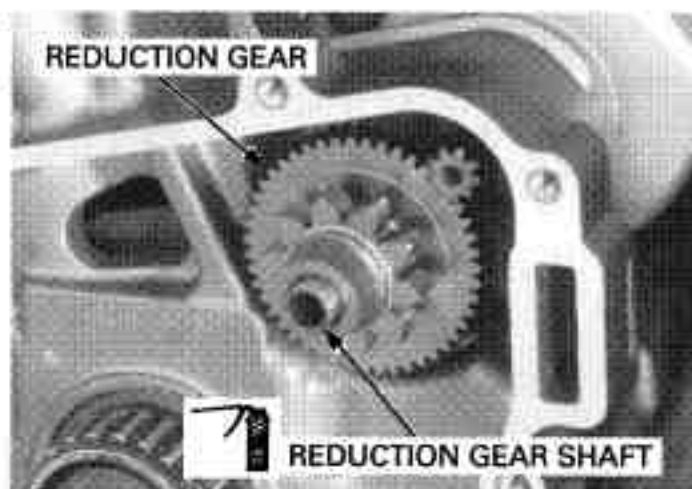

Clean any oil from the crankshaft taper.
Install the woodruff key on the crankshaft.

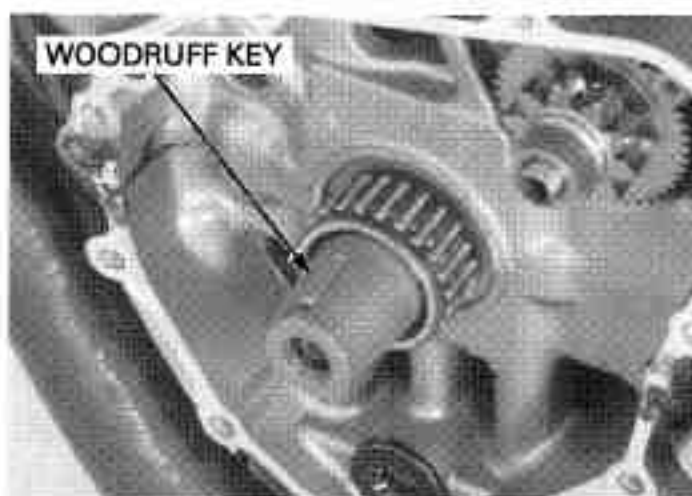

Install the flywheel aligning the key way in the flywheel with the woodruff key on the crankshaft.

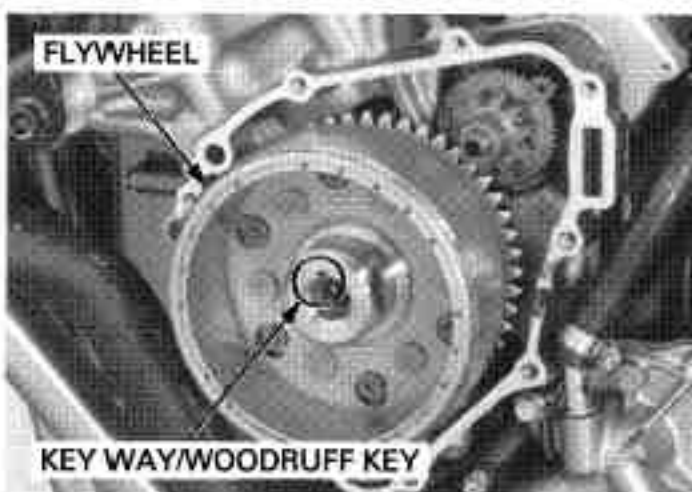

Apply oil to the flywheel bolt threads and seating surface.

Install the washer and flywheel bolt.

Hold the flywheel using the flywheel holder, then tighten the bolt to the specified torque.

TOOL:

Flywheel holder 07725-0040000 or equivalent commercially available in U.S.A.

TORQUE: 103 N-m (10.5 kgf-m, 76 lbf-ft)



ALTERNATOR COVER INSTALLATION

Apply sealant to the mating surface of the crankcase as shown.

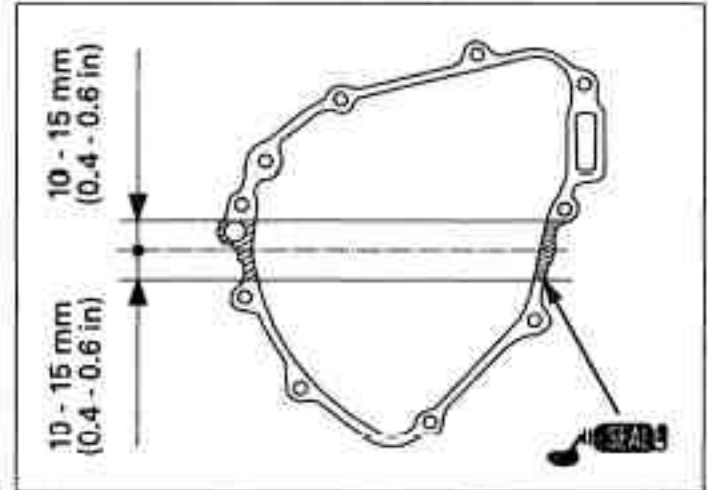

Install the dowel pin and new gasket.

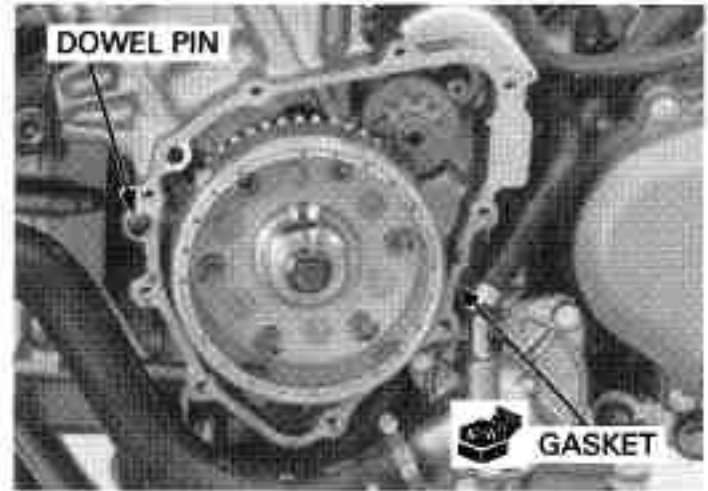

The alternator cover (stator) is magnetically attached to the flywheel, be careful during installation.

Install the alternator cover.
Install and tighten the bolts securely.

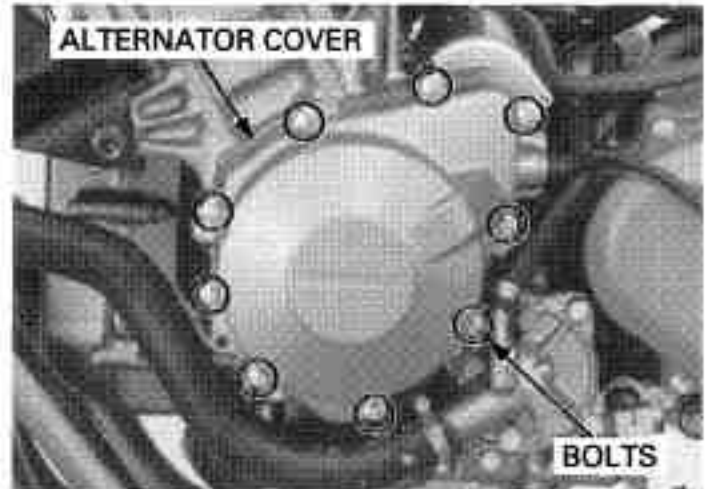

Route the alternator wire properly (page 1-23).
Clamp the alternator wire with a wire clamp.

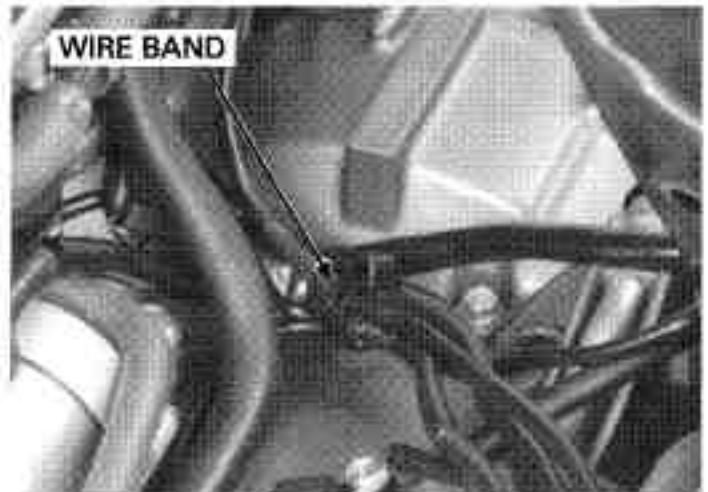

ALTERNATOR/STARTER CLUTCH

Connect the alternator 3P (Natural) connector.
Install the air cleaner housing (page 6-8).
Pour the recommended engine oil (page 4-15).

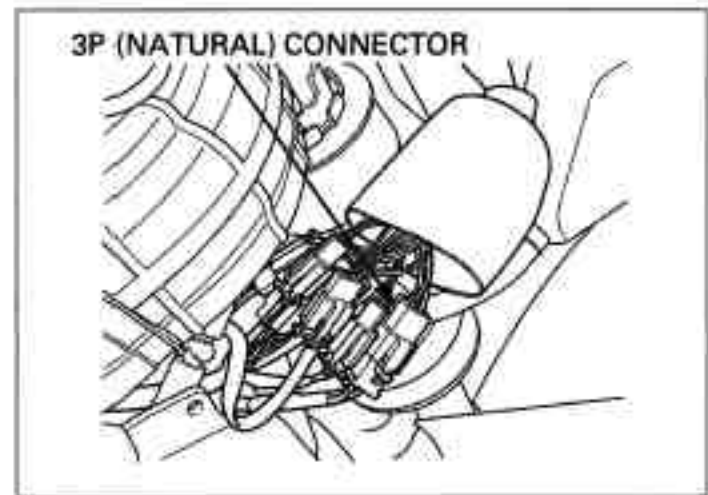

12. CRANKCASE/TRANSMISSION

COMPONENT LOCATION	12-2	SHIFT FORK/SHIFT DRUM	12-6
SERVICE INFORMATION	12-3	TRANSMISSION	12-8
TROUBLESHOOTING	12-4	CRANKCASE ASSEMBLY	12-14
CRANKCASE SEPARATION	12-5		

CRANKCASE/TRANSMISSION

COMPONENT LOCATION

26 N·m (2.7 kgf·m, 20 lbf·ft)

39 N·m (4.0 kgf·m, 29 lbf·ft)

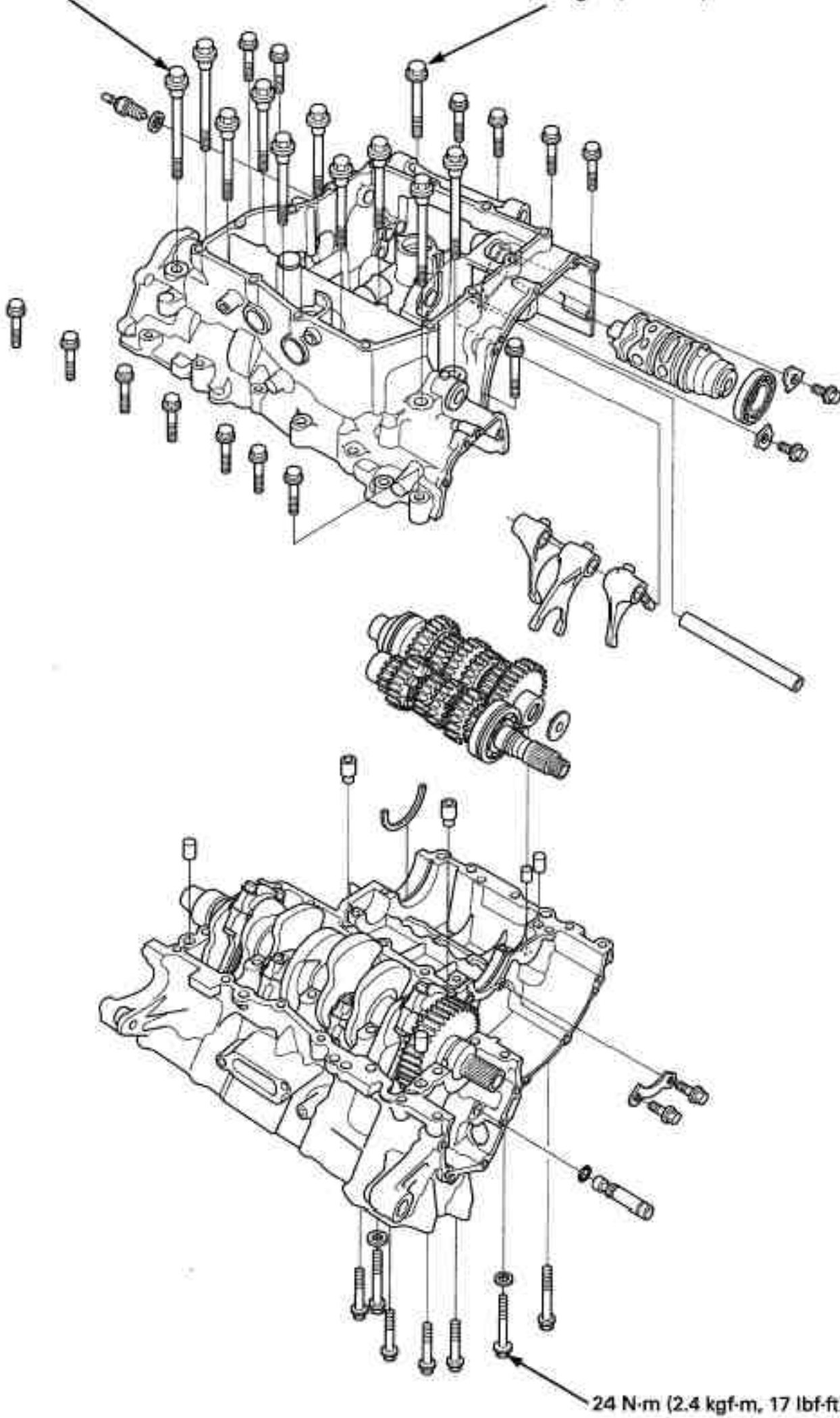

SERVICE INFORMATION

GENERAL

- The crankcase must be separated to service the following:
 - Transmission
 - Crankshaft
 - Piston/connecting rod
- The following components must be removed before separating the crankcase:
 - Alternator (page 11-4) / flywheel (page 11-6)
 - Clutch (page 10-7) / gearshift linkage (page 10-15)
 - Cylinder head (page 9-12)
 - Engine (page 8-4)
 - Oil pan (page 5-6), oil pump (page 5-8) and oil cooler (page 5-14)
 - Starter motor (page 19-6)
 - Water pump (page 7-16)
- Be careful not to damage the crankcase mating surfaces when servicing.
- Prior to assembling the crankcase halves, apply sealant to their mating surfaces, Wipe off excess sealant thoroughly.

SPECIFICATIONS

Unit: mm (in)

ITEM		STANDARD	SERVICE LIMIT
Shift fork, fork shaft	I.D.	12.000 – 12.021 (0.4724 – 0.4733)	12.03 (0.474)
	Claw thickness	5.93 – 6.00 (0.233 – 0.236)	5.9 (0.23)
	Shift fork shaft O.D.	11.957 – 11.968 (0.4707 – 0.4712)	11.95 (0.470)
Transmission	Gear I.D.	M5, M6	28.000 – 28.021 (1.1024 – 1.1032)
		C2, C3, C4	31.000 – 31.025 (1.2205 – 1.2215)
	Gear busing O.D.	M5, M6	27.959 – 27.980 (1.1007 – 1.1016)
		C2, C3, C4	30.950 – 30.975 (1.2189 – 1.2197)
	Gear-to-bushing clearance	M5, M6	0.020 – 0.062 (0.0008 – 0.0024)
		C2, C3, C4	0.025 – 0.075 (0.0010 – 0.0030)
	Gear bushing I.D.	M5	24.985 – 25.006 (0.9837 – 0.9845)
		C2	27.985 – 28.006 (1.1018 – 1.1026)
	Mainshaft O.D.	at M5	24.967 – 24.980 (0.9830 – 0.9835)
	Countershaft O.D.	at C2	27.967 – 27.980 (1.1011 – 1.1016)
Bushing to shaft clearance	M5	0.005 – 0.039 (0.0002 – 0.0015)	
	C2	0.005 – 0.039 (0.0002 – 0.0015)	

TORQUE VALUES

Main journal bolt	26 N·m (2.7 kgf·m, 20 lbf·ft)	Apply oil to the threads and flange surface
Crankcase bolt, 10 mm	39 N·m (4.0 kgf·m, 29 lbf·ft)	
8 mm	24 N·m (2.4 kgf·m, 17 lbf·ft)	
Lower crankcase sealing bolt, 20 mm	30 N·m (3.1 kgf·m, 22 lbf·ft)	Apply a locking agent to the threads
Lower crankcase sealing bolt, 14 mm	25 N·m (2.5 kgf·m, 18 lbf·ft)	Apply a locking agent to the threads

CRANKCASE/TRANSMISSION

TOOLS

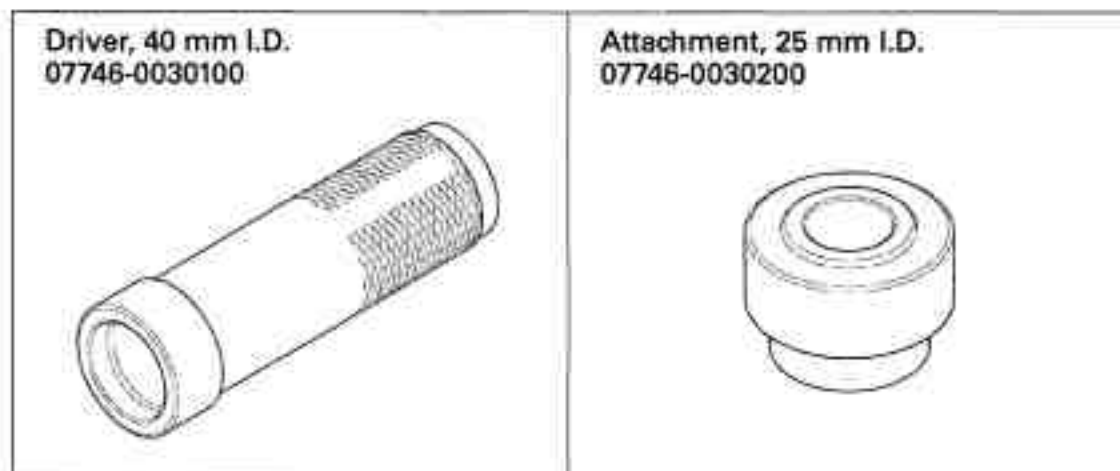

TROUBLESHOOTING

Hard to shift

- Improper clutch adjustment (page 4-30)
- Improper clutch operation (page 10-7)
- Incorrect transmission oil weight
- Bent shift fork
- Bent shift fork shaft
- Bent shift fork claw
- Damaged shift drum center groove
- Bent gearshift spindle

Transmission jumps out of gear

- Worn gear dogs and slots
- Worn gear shifter groove
- Bent shift fork shaft
- Broken shift drum stopper arm
- Broken shift drum stopper arm spring
- Worn or bent shift forks
- Broken gearshift spindle return spring

Excessive engine noise

- Worn or damaged transmission gear
- Worn or damaged transmission bearings

CRANKCASE SEPARATION

Refer to Service Information (page 12-3) for removal of necessary parts before separating the crankcase.

Disconnect the neutral switch connector.

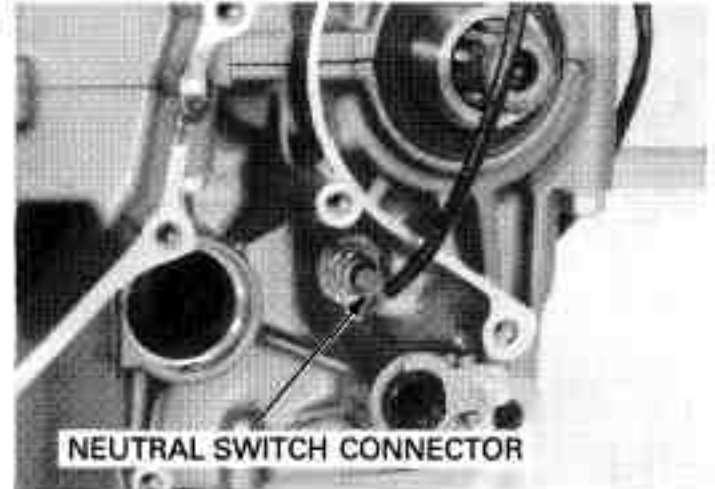

Remove the speed sensor before separating the crankcase. Do not separate or assemble the crankcase with the speed sensor installed.

Remove the speed sensor.
Remove the oil pressure switch.

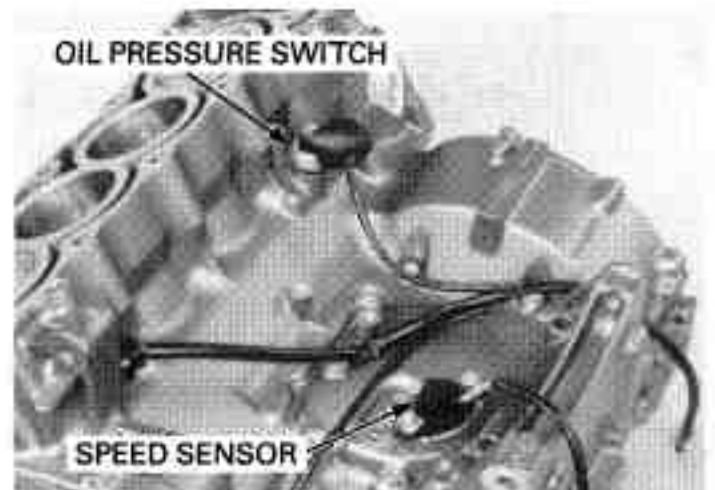

Loosen the upper crankcase 6 mm bolts and 8 mm bolt/sealing washers in a crisscross pattern in 2 or 3 steps.
Remove the bolts and sealing washer.

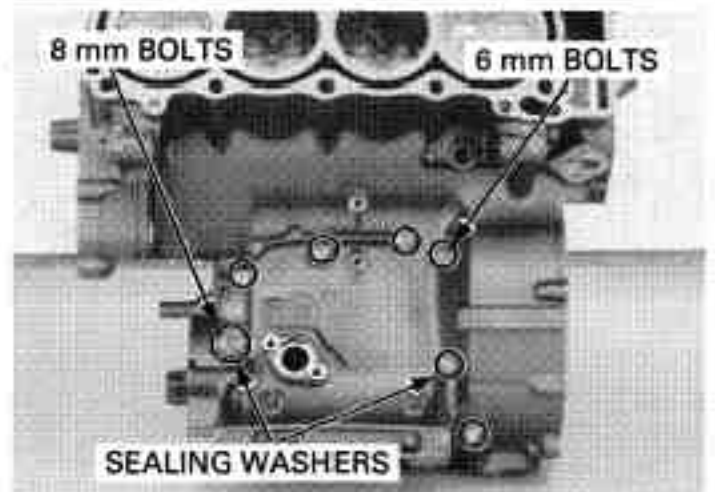

Place the engine with the upside down.
Loosen and remove the 6 mm bolts and 10 mm bolt.
Loosen the main journal 8 mm bolts in a crisscross pattern in 2 or 3 steps.
Remove the 8 mm bolts and sealing washers.

Separate the lower crankcase from the upper crankcase.

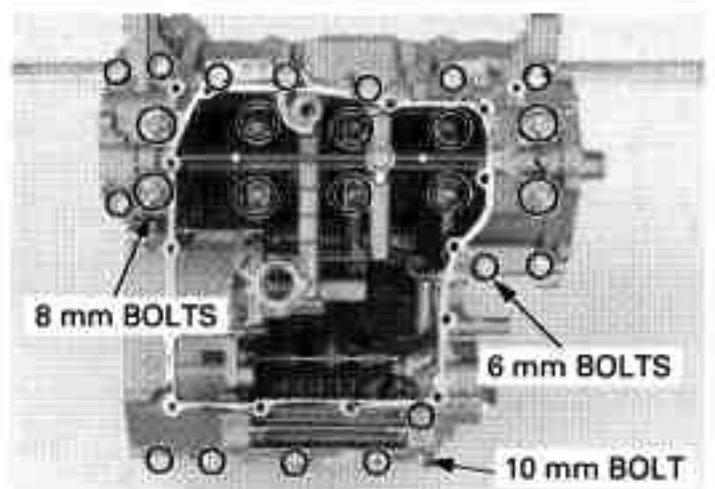

CRANKCASE/TRANSMISSION

Remove the three dowel pins and two oil orifices.
Clean any sealant off from the crankcase mating surface.

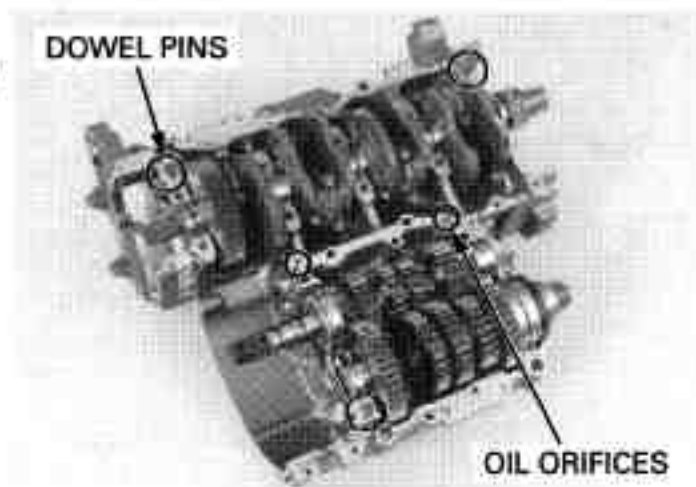

SHIFT FORK/SHIFT DRUM

REMOVAL

Separate the crankcase halves (page 12-5).
Remove the bolts and shift drum bearing set plates.

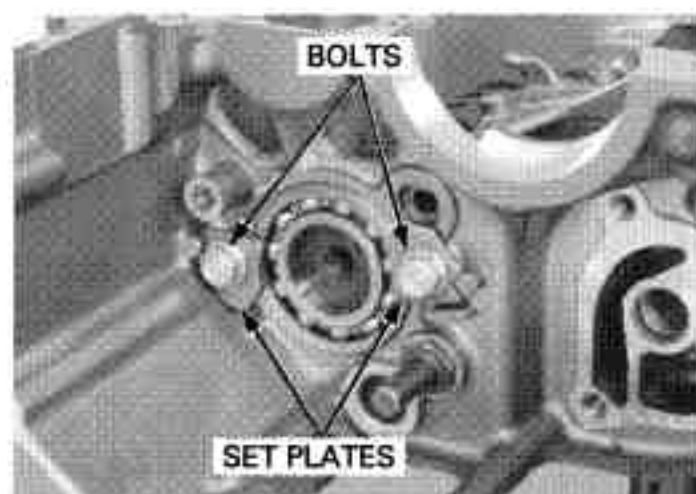

Remove the shift fork shaft and shift forks.

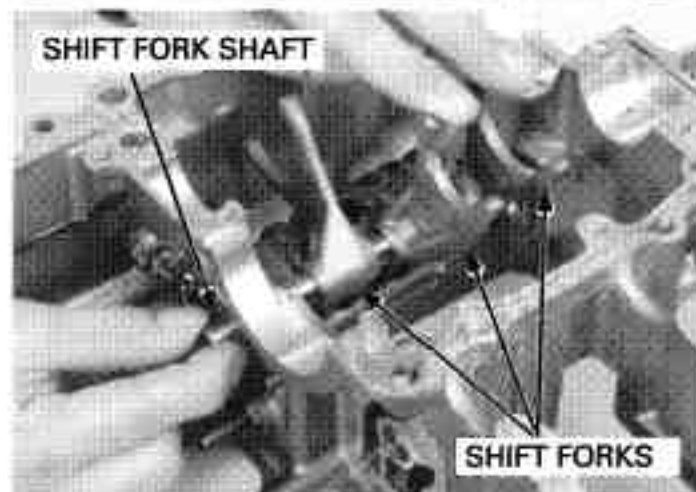

Remove the shift drum bearing and shift drum.

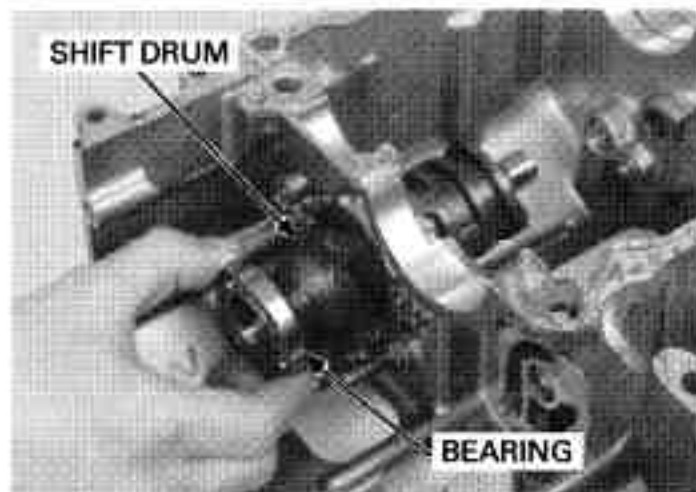

SHIFT DRUM/SHIFT FORK INSPECTION

Check the shift fork guide pin for abnormal wear or damage

Measure the shift fork I.D.

SERVICE LIMIT: 12.03 mm (0.474 in)

Measure the shift fork claw thickness.

SERVICE LIMIT: 5.9 mm (0.23 in)

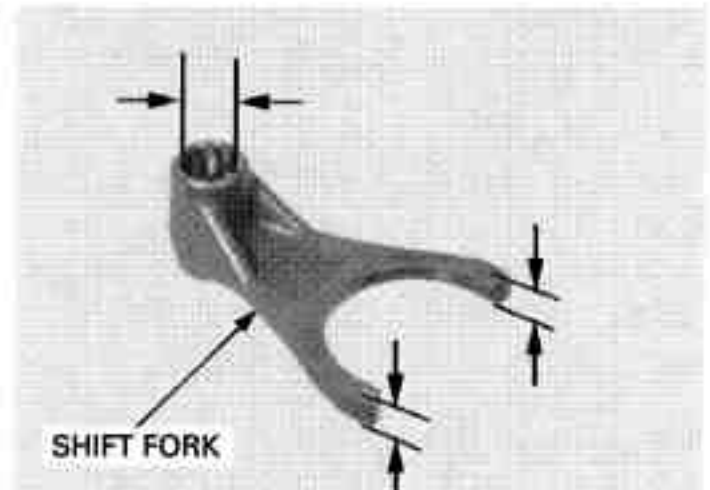

Measure the shift fork shaft O.D.

SERVICE LIMIT: 11.95 mm (0.470 in)

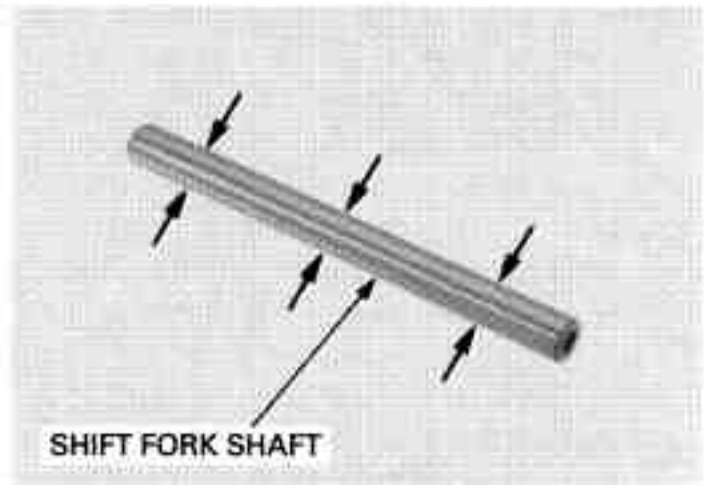

Inspect the shift drum guide grooves for wear or damage.

Turn the outer race of the shift drum bearing with your finger.

The bearing should turn smoothly and freely without excessive play.

If necessary replace the bearing.

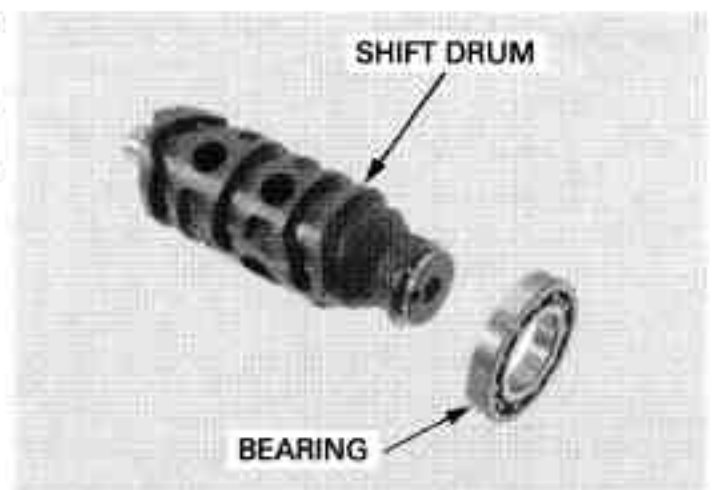

INSTALLATION

Install the shift drum and shift drum bearing into the lower crankcase.

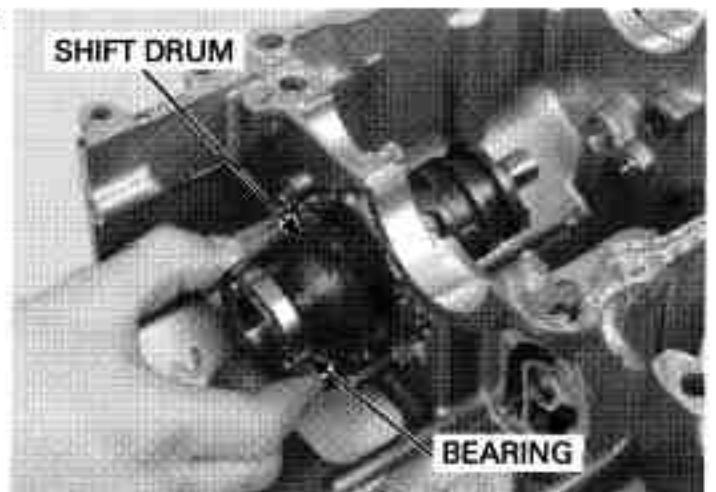

CRANKCASE/TRANSMISSION

The shift forks have location marks:

- "R" for right
- "L" for left
- "C" for center

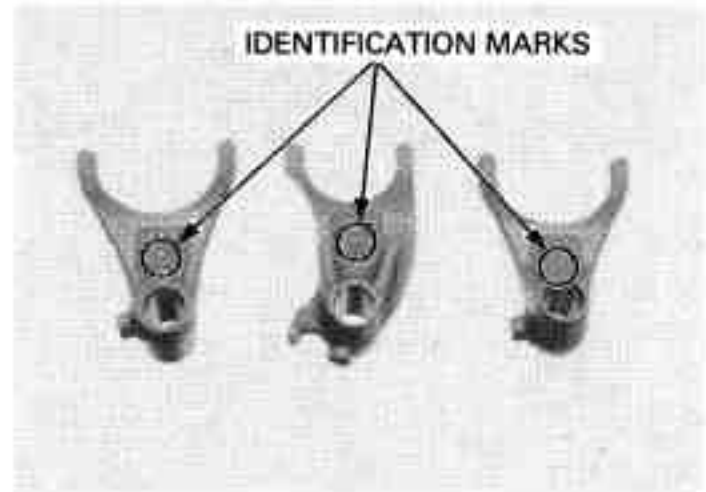

Install the shift forks into the shift drum guide groove with the identification marks facing toward the right side of the engine and insert the fork shaft.

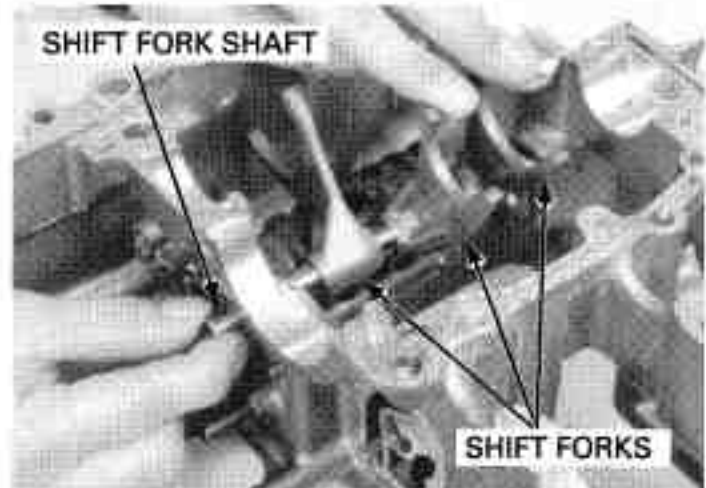

Apply a locking agent to the threads of the bolt. Install the shift drum bearing set plates with their "OUT" mark facing out. Install and tighten the bolts securely.

Assemble the crankcase halves (page 12-12).

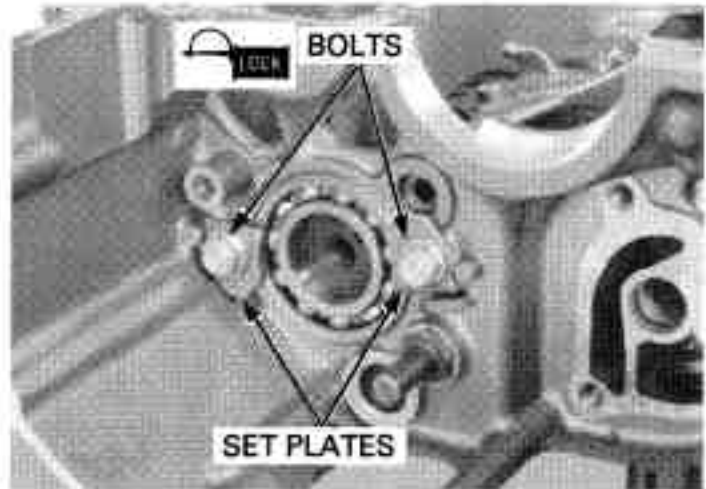

TRANSMISSION

REMOVAL/DISASSEMBLY

Separate the crankcase halves (page 12-5).

Remove the bolts and mainshaft bearing set plate.

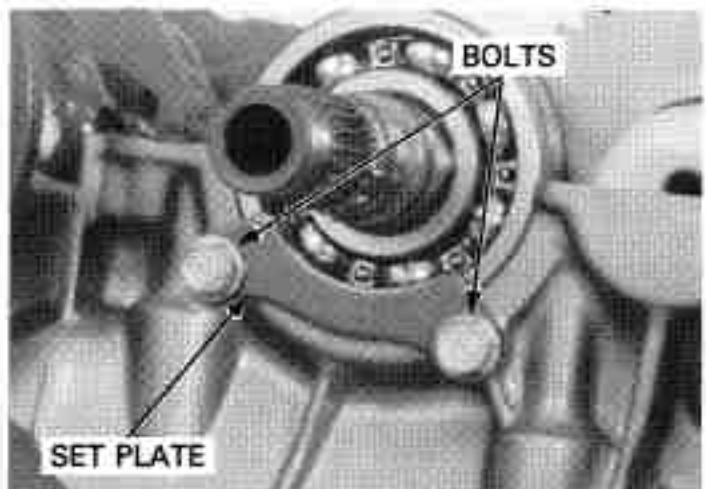

Remove the countershaft assembly and bearing set ring.

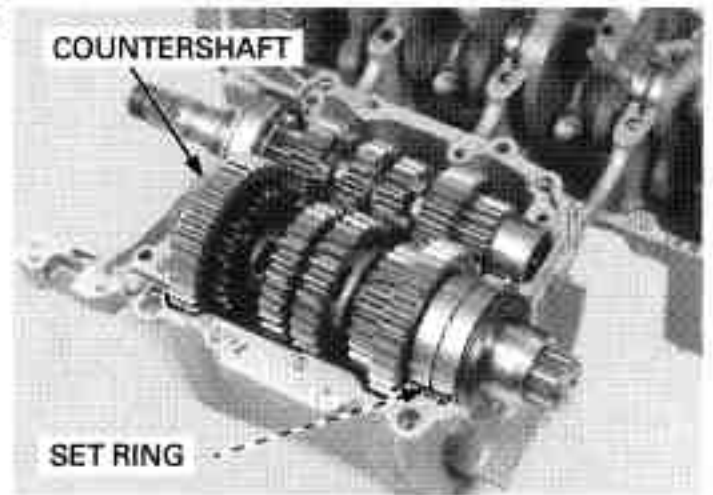

Remove the mainshaft assembly.

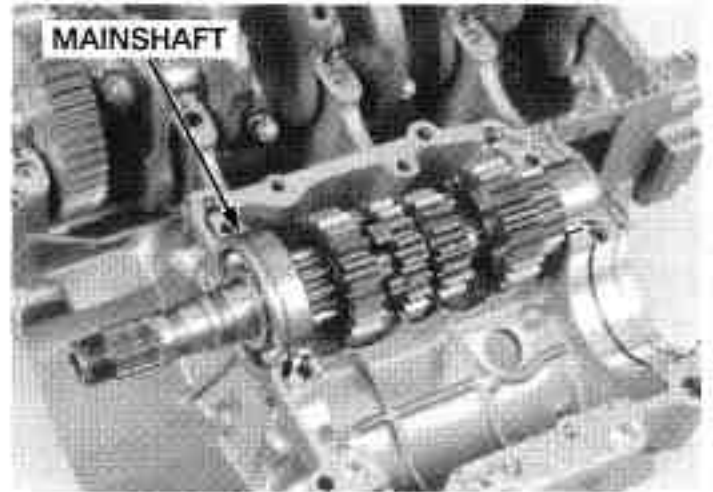

Disassemble the mainshaft and countershaft.
Clean all disassembled parts in solvent thoroughly.

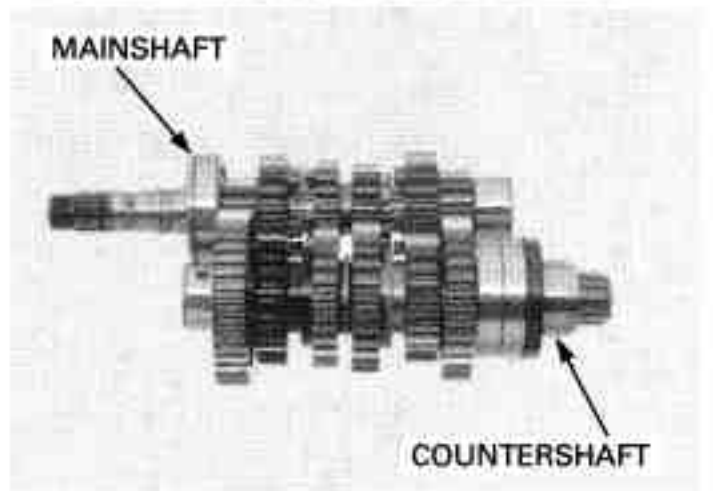

INSPECTION

Check the mainshaft and countershaft needle bearings for wear or damage.

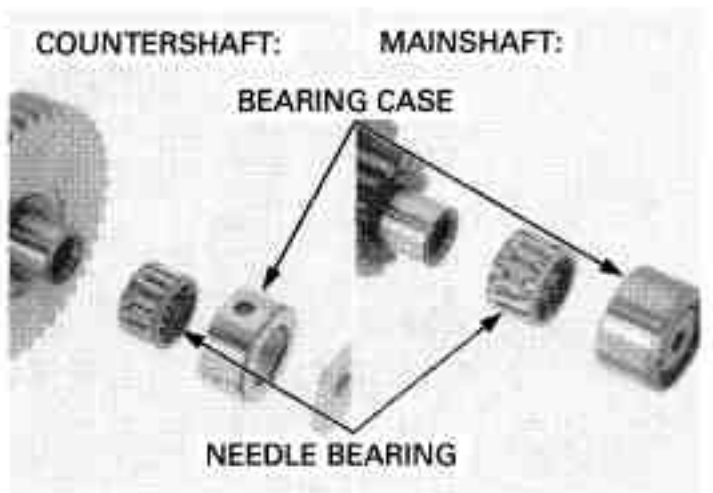

CRANKCASE/TRANSMISSION

Check the gear dogs, dog holes and teeth for abnormal wear or lack of lubrication.

Measure the I.D. of each gear.

SERVICE LIMITS:

M5, M6: 28.04 mm (1.104 in)

C2, C3, C4: 31.04 mm (1.222 in)

Check the gear shifter groove for abnormal wear or damage.

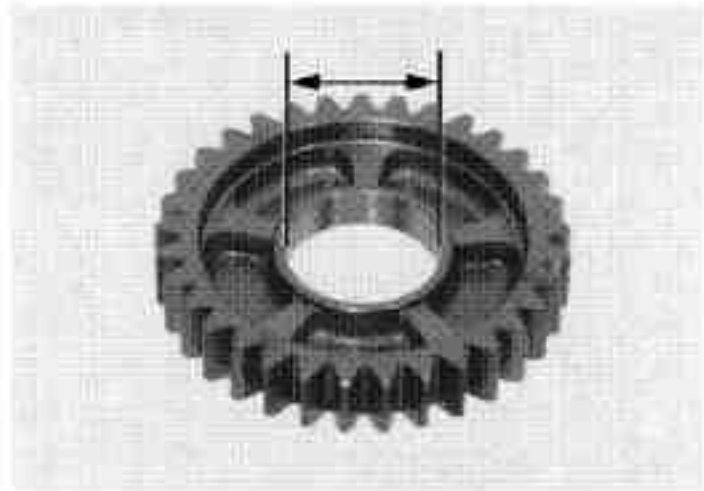

Measure the O.D. of each gear bushing.

SERVICE LIMITS:

M5, M6: 27.94 mm (1.100 in)

C2, C3, C4: 30.94 mm (1.218 in)

Measure the I.D. of each gear bushing.

SERVICE LIMITS:

M5: 25.016 mm (0.9849 in)

C2: 28.021 mm (1.1032 in)

Calculate the gear-to-bushing clearance.

SERVICE LIMITS:

M5, M6: 0.10 mm (0.004 in)

C2, C3, C4: 0.11 mm (0.004 in)

Check the mainshaft and countershaft for abnormal wear or damage.

Measure the mainshaft O.D. at the M5 gear.

SERVICE LIMIT: 24.96 mm (0.983 in)

Measure the countershaft O.D. at the C2 gear.

SERVICE LIMIT: 27.96 mm (1.101 in)

Calculate the gear bushing-to-shaft clearance.

SERVICE LIMITS:

M5: 0.06 mm (0.002 in)

C2: 0.06 mm (0.002 in)

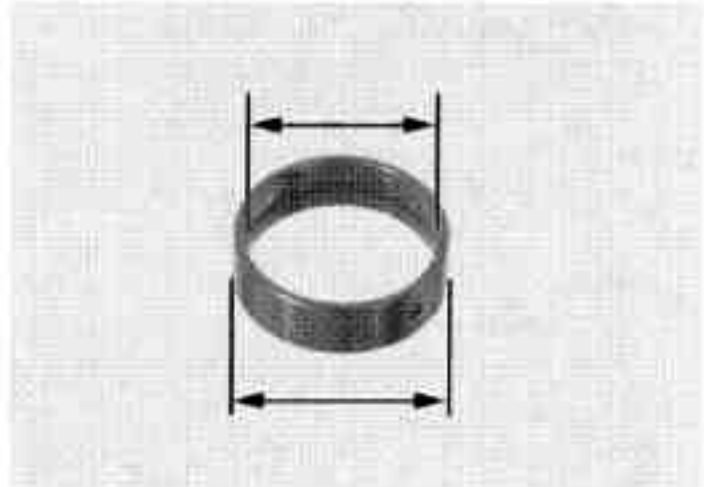

Turn the outer race of each bearing with your finger. The bearings should turn smoothly and quietly. Also check that the bearing inner race fits tightly on the shaft.

Remove and discard the mainshaft bearing, if the race does not turn smoothly, quietly, or fits loosely on the mainshaft.

Replace the countershaft, collar, and bearing as an assembly, if the race does not turn smoothly, quietly, or fits loosely on the countershaft.

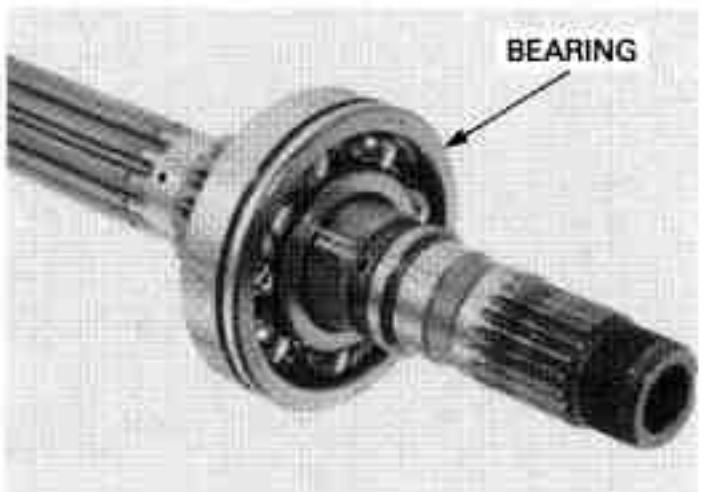
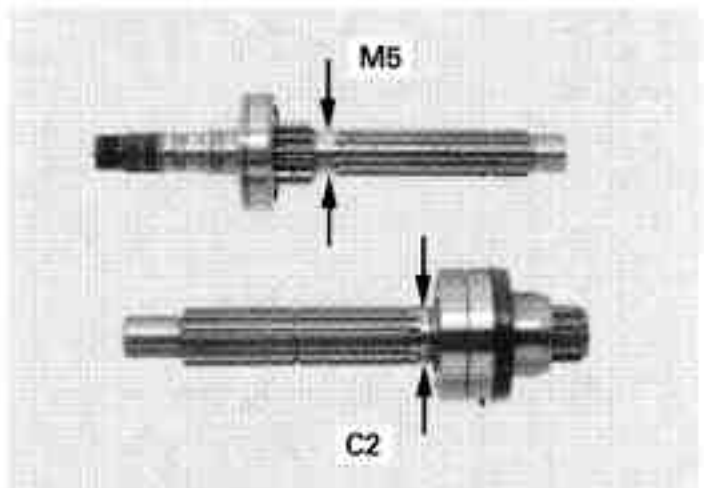

MAINSHAFT BEARING REPLACEMENT

Press out the mainshaft from the bearing using a hydraulic press.

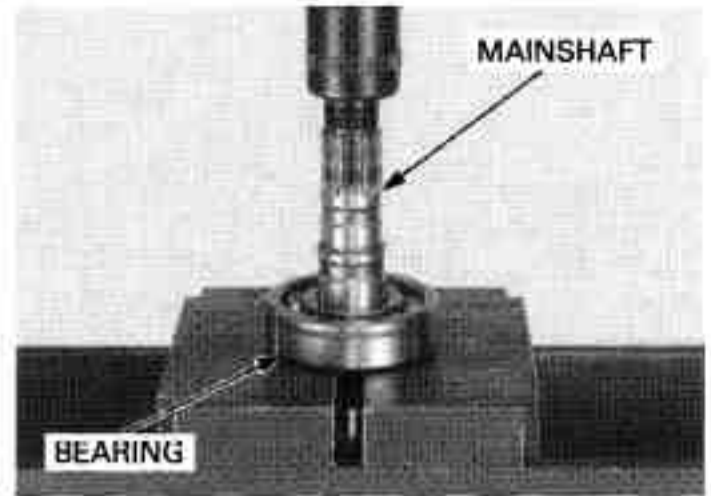

Install with the groove side facing up.

Install a new mainshaft bearing onto the mainshaft by pressing the mainshaft bearing inner race using the special tools.

TOOLS:

- Driver, 40 mm I.D. 07746-0030100
- Attachment, 25 mm I.D. 07746-0030200

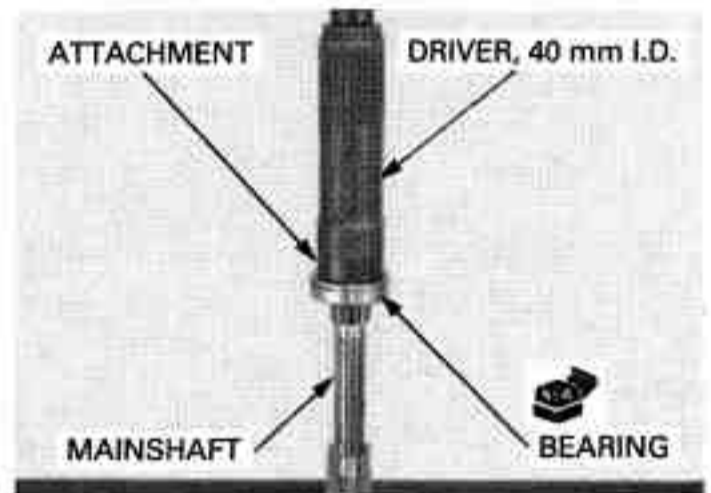

**ASSEMBLY
MAINSHAFT**

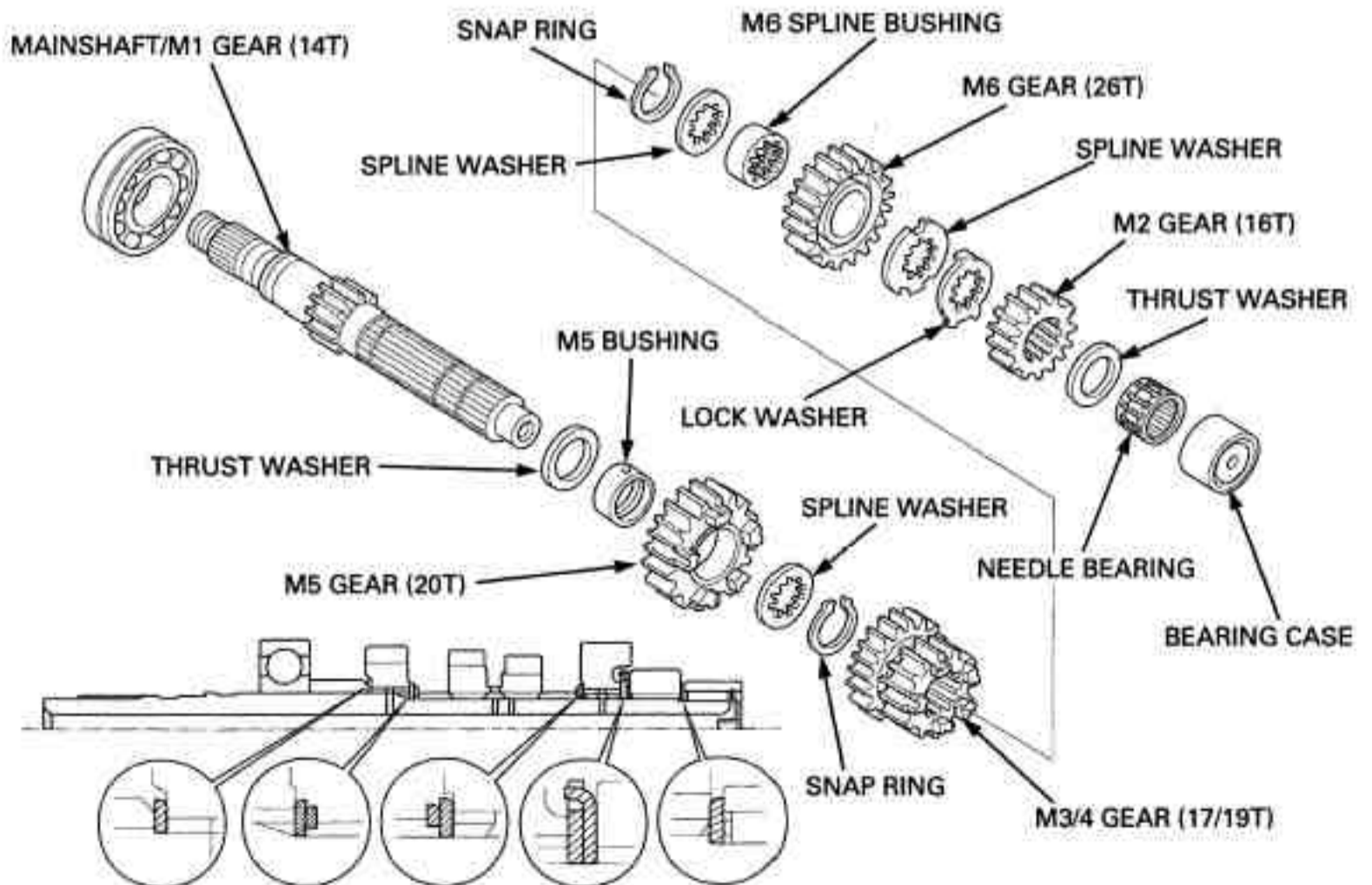

CRANKCASE/TRANSMISSION

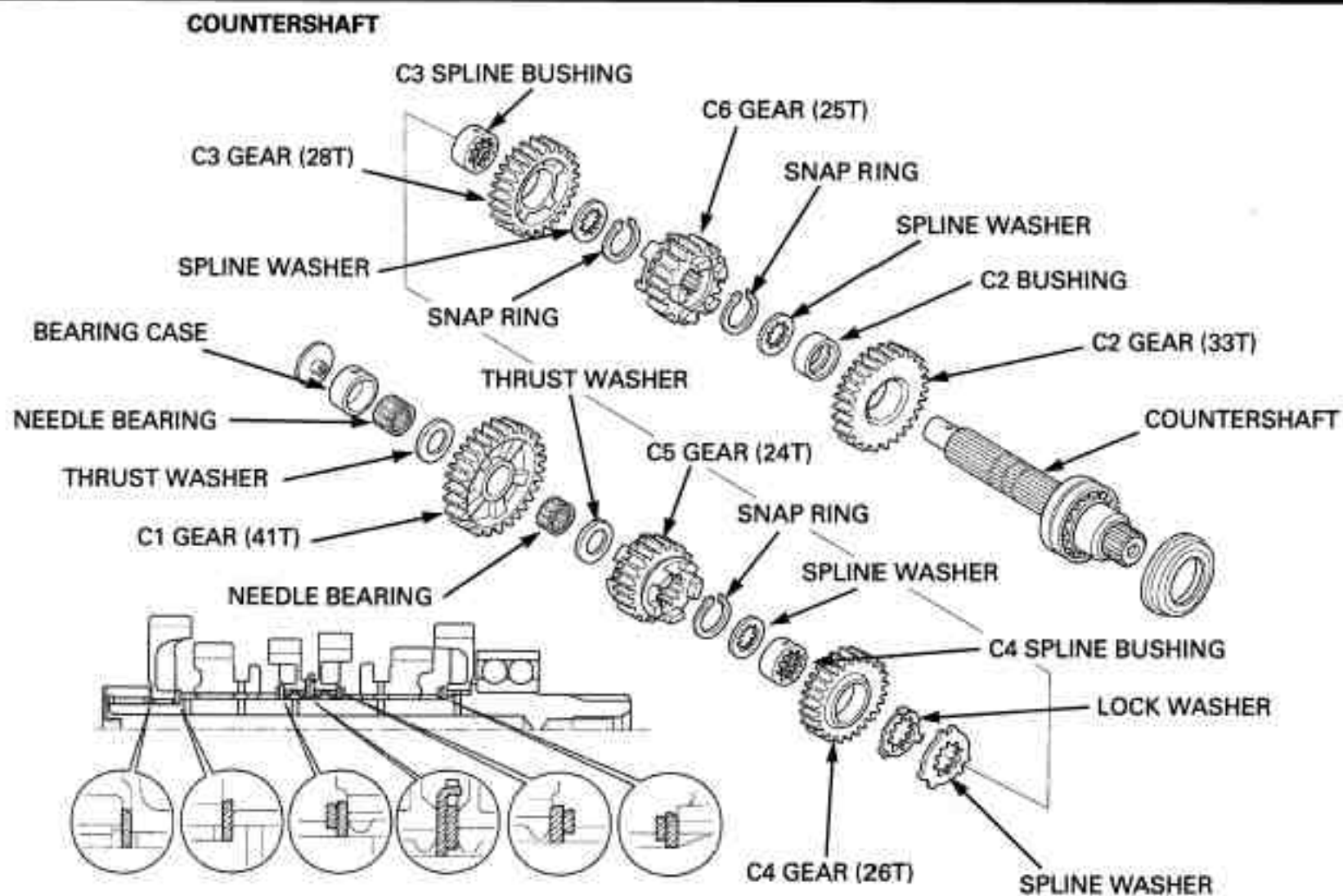

Assemble the transmission gear and shafts.
Coat each gear with clean engine oil and check for smooth movement.
Align the oil holes in the M6 bushing and mainshaft, and the C3, C4 spline bushings and countershaft.

- Align the lock washer tabs with the spline washer grooves.
- Always install the thrust washer and snap ring with the chamfered (rolled) edge facing away from the thrust load.
- Install the snap ring so that its end gap aligns with the groove in the splines.
- Make sure that the snap ring is fully seated in the shaft groove after installing it.

INSTALLATION

Apply molybdenum oil solution to the shift fork grooves in the M3/4, C5 and C6 gear.

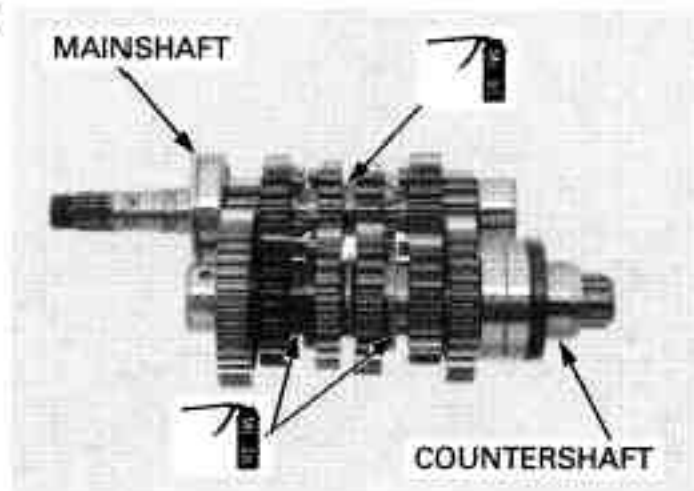

Install the mainshaft assembly onto the upper crankcase.

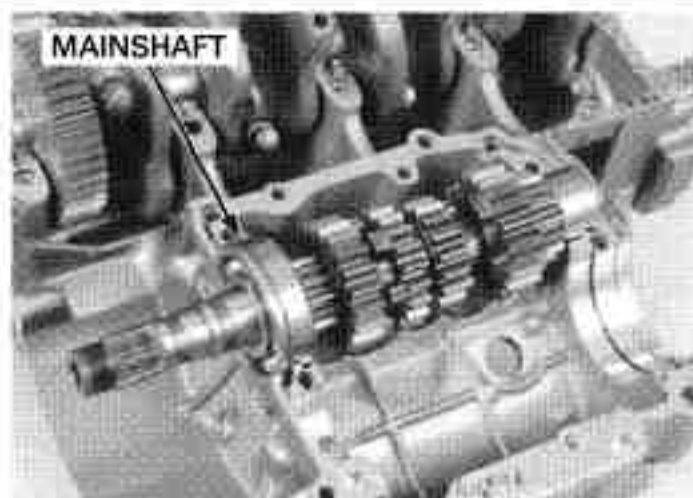

Install the countershaft assembly by aligning the countershaft bearing groove with the set ring on the upper crankcase, and aligning the bearing cap holes with the dowel pins.

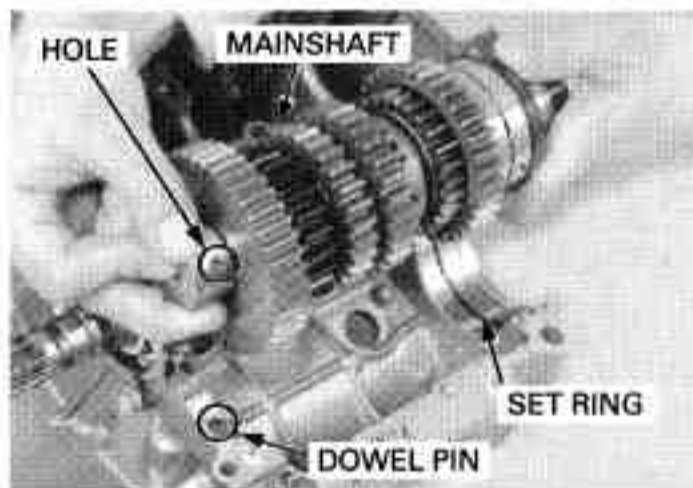

Also align the countershaft bearing stopper pin with the groove in the upper crankcase.

After installation, check for smooth transmission operation.



Clean and apply a locking agent to the bolt threads. Install the mainshaft set plate with its "OUT SIDE" mark facing out.

Install and tighten the bolts securely.

Assemble the crankcase halves (page 12-14).

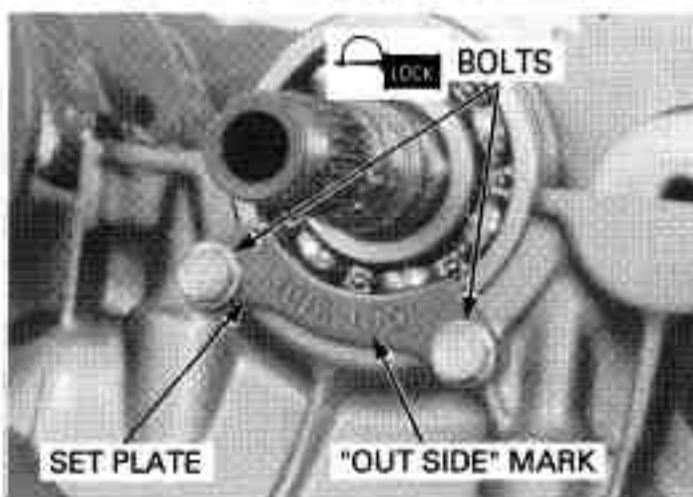

CRANKCASE/TRANSMISSION

CRANKCASE ASSEMBLY

Apply a light, but thorough, coating of liquid sealant to the crankcase mating surface except to the main bearing journal bolt (lower crankcase bolt, 8 mm) area and the oil passage area as shown.

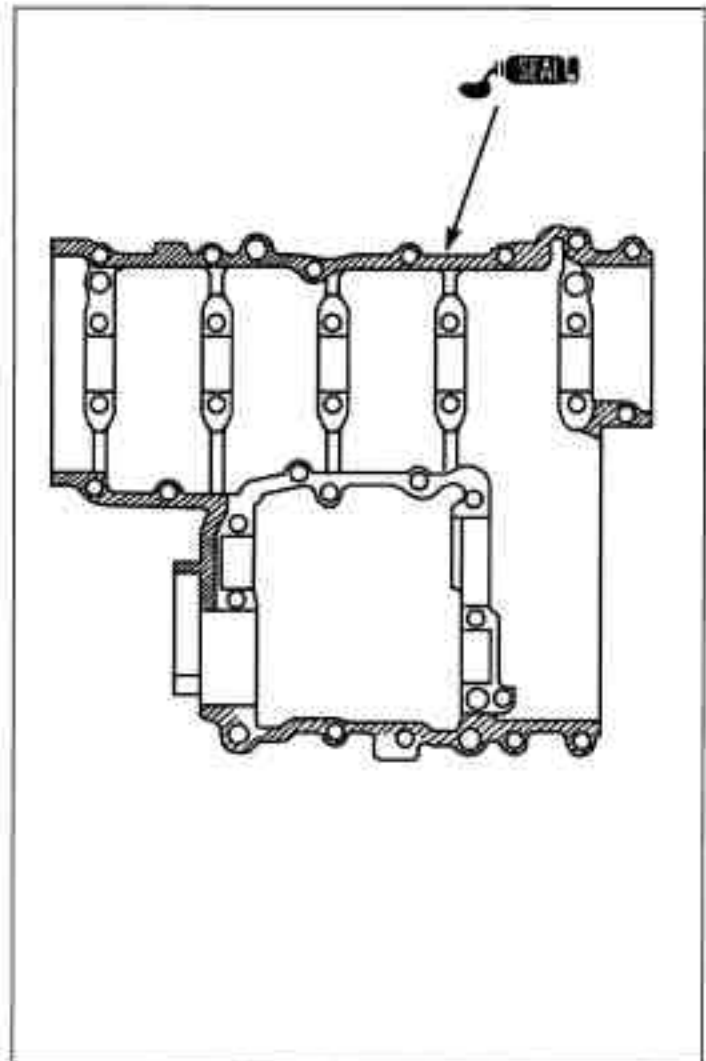

Install oil orifices aligning their cut-out with the groove in the upper crankcase.

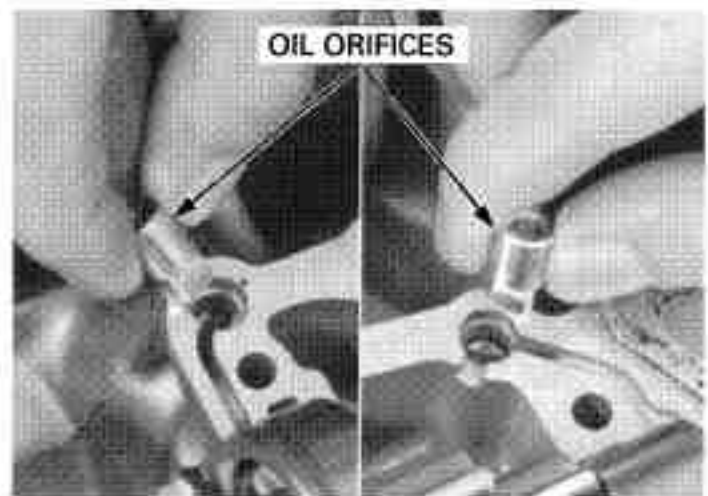

Install the dowel pins to the upper crankcase.

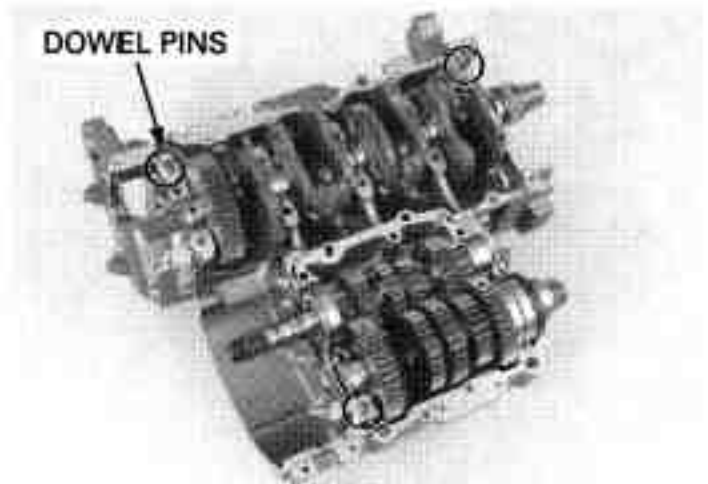

Assemble the crankcase halves, aligning the shift fork claws with the shifter gear grooves.
Check for smooth transmission operation.

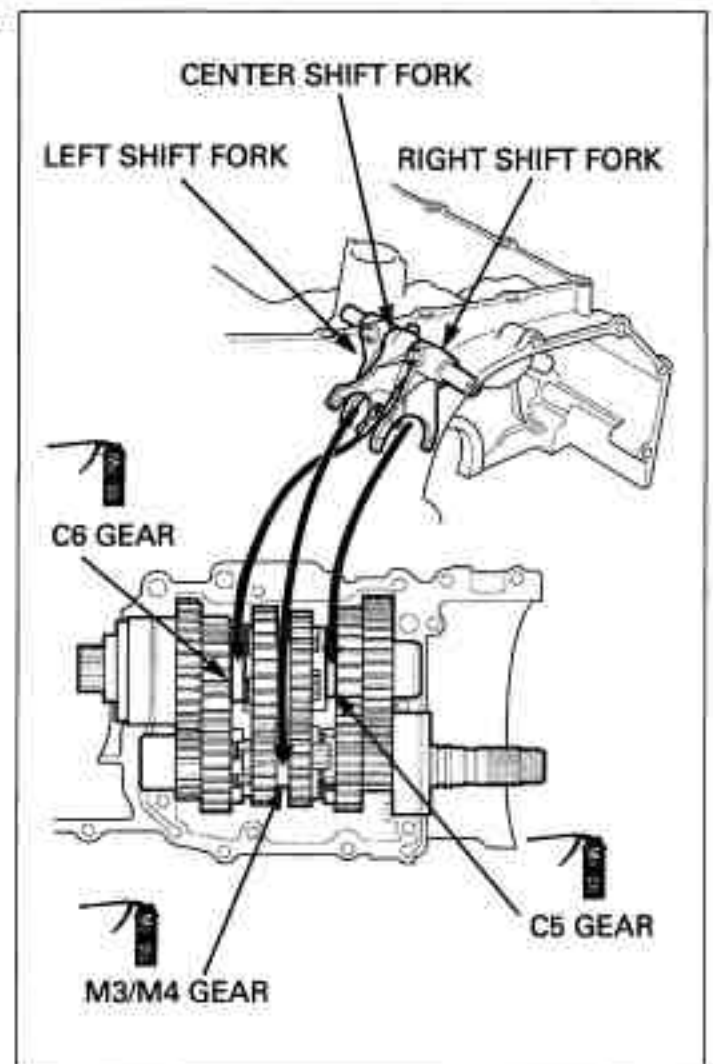

Apply oil to the main journal 8 mm bolt threads and seating surface and install them.
Install the main journal 8 mm bolts.
Install the 10 mm bolt and 6 mm bolts.

Make sure the upper and lower crankcase are seated securely.

From the inside to outside, tighten the main journal 8 mm bolts in a crisscross pattern in 2 or 3 steps.

TORQUE: 26 N·m (2.7 kgf·m, 20 lbf·ft)

Tighten the 10 mm bolt to the specified torque, and then tighten 6 mm bolts securely.

TORQUE: 39 N·m (4.0 kgf·m, 29 lbf·ft)

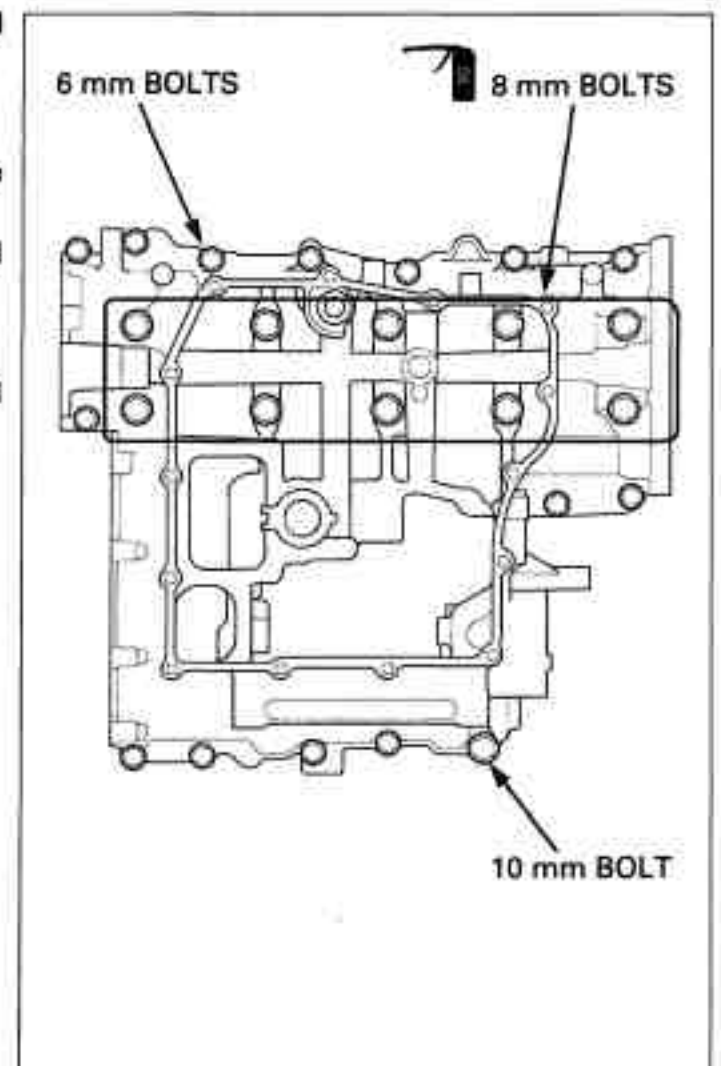

CRANKCASE/TRANSMISSION

The sealing washer locations are indicated on the upper crankcase using the "Δ" mark.

Install the upper crankcase 8 mm bolt and 6 mm bolts with new sealing washers.

Tighten the 8 mm bolt to the specified torque.

TORQUE: 24 N·m (2.4 kgf·m, 17 lbf·ft)

Tighten the 6 mm bolts in a crisscross pattern in 2 or 3 steps securely.

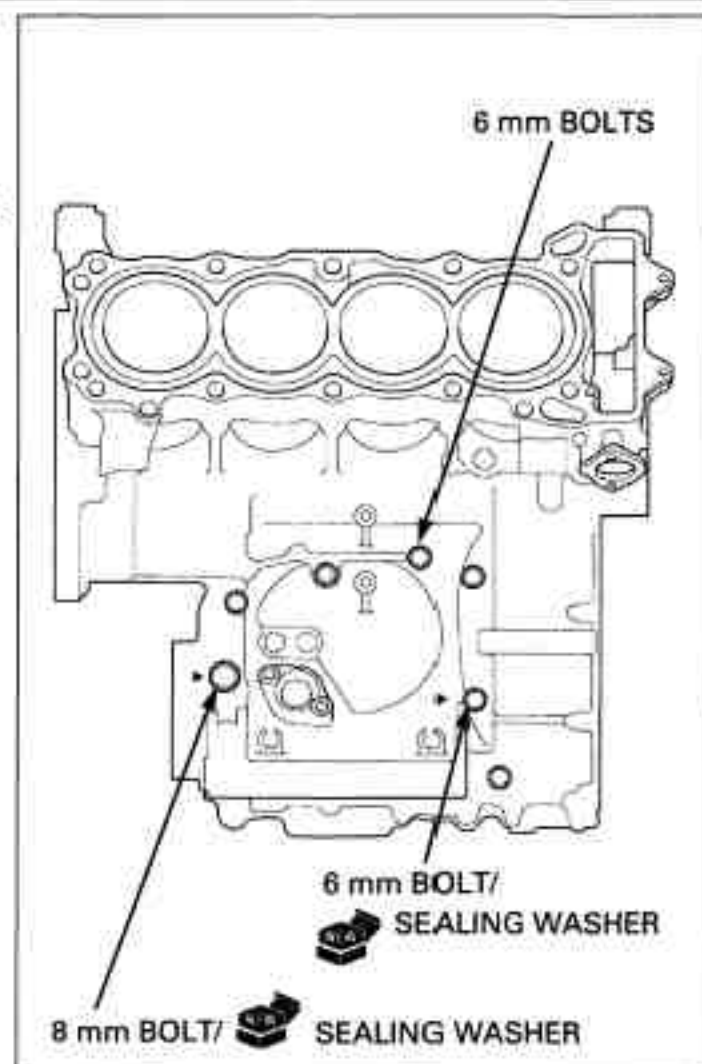

Install the speed sensor.
Install the oil pressure switch.

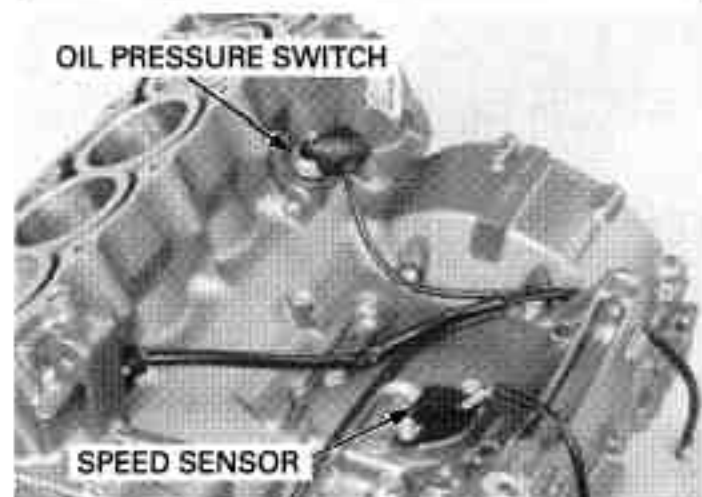

Connect the neutral switch connector.
Install the removed parts in the reverse order of removal.

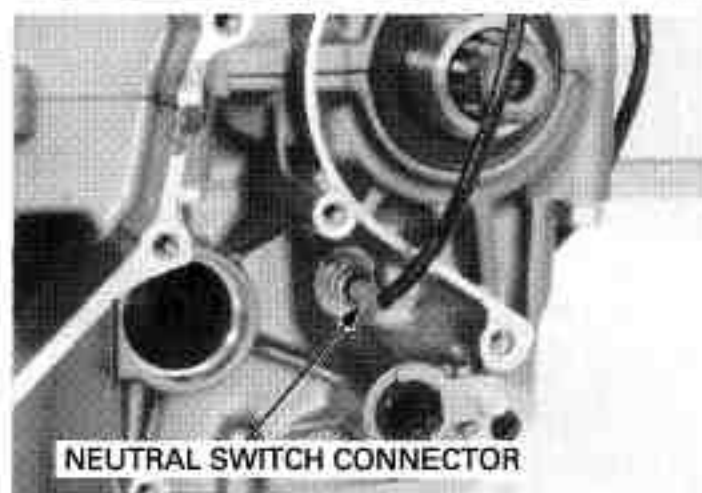

13. CRANKSHAFT/PISTON/CYLINDER

COMPONENT LOCATION	13-2	MAIN JOURNAL BEARING.....	13-7
SERVICE INFORMATION	13-3	CRANKPIN BEARING	13-10
TROUBLESHOOTING	13-4	PISTON/CYLINDER	13-12
CRANKSHAFT.....	13-5		

COMPONENT LOCATION

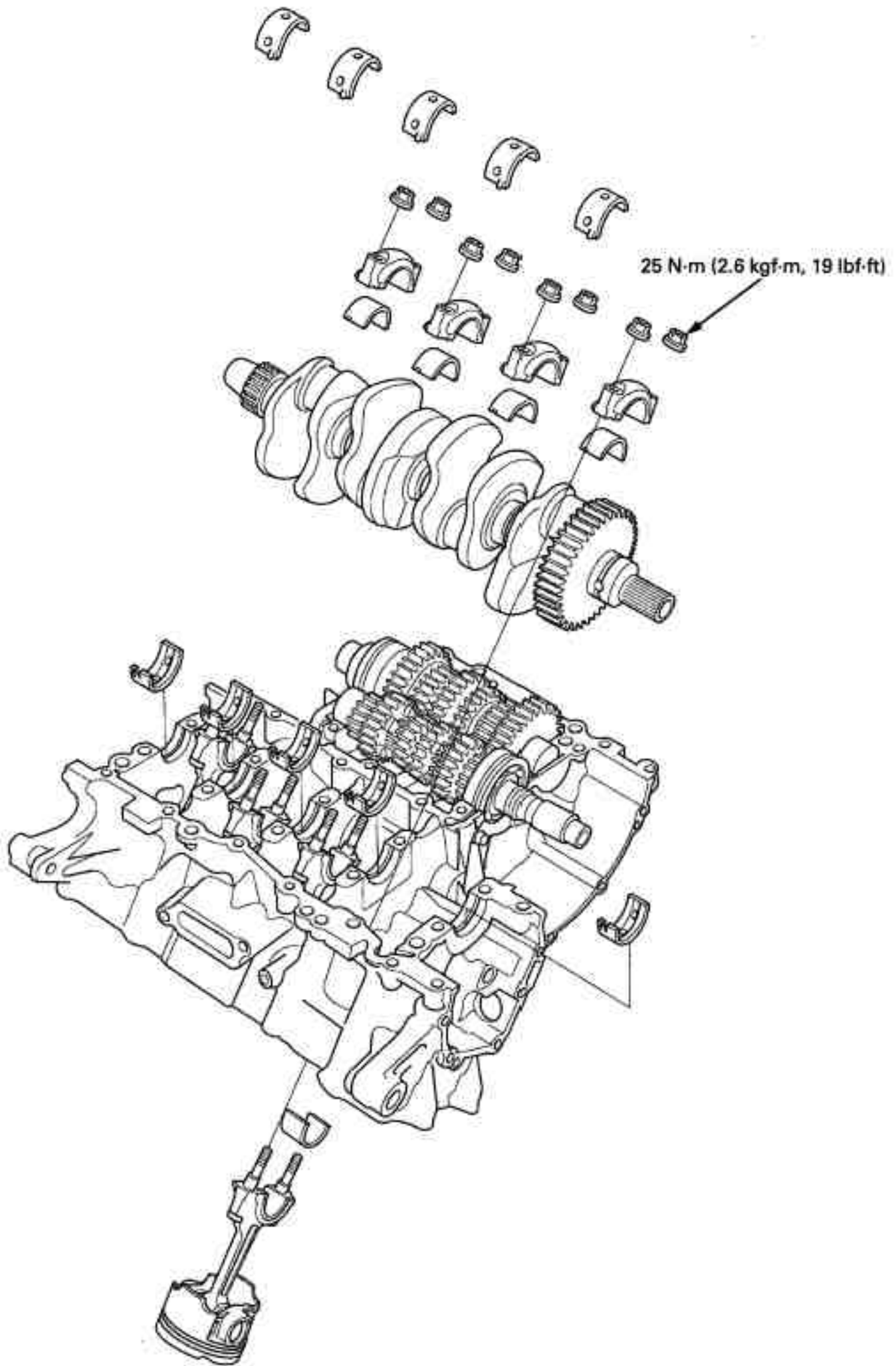

SERVICE INFORMATION

GENERAL

- The crankcase must be separated to service the crankshaft and piston/connecting rod. Refer to procedures for crankcase separation (page 12-5) and assembly (page 12-14).
- Be careful not to damage the crankshaft main journal and journal bearing while removing or installing the crankshaft.
- Be careful not to damage the cylinder bore while removing or installing the piston/connecting rod.
- Mark and store the connecting rods, bearing caps, pistons and bearing inserts to be sure of their correct locations for reassembly.
- The crankpin and main journal bearing inserts are select fit and are identified by color codes. Select replacement bearings from the code tables. After selecting new bearings, recheck the oil clearance with a plastigauge. Incorrect oil clearance can cause major engine damage.

SPECIFICATIONS

Unit: mm (in)

ITEM		STANDARD	SERVICE LIMIT	
Crankshaft	Connecting rod side clearance	0.10 – 0.25 (0.004 – 0.010)	0.30 (0.012)	
	Crankpin bearing oil clearance	0.028 – 0.052 (0.0011 – 0.0020)	0.06 (0.002)	
	Main journal bearing oil clearance	0.020 – 0.045 (0.0008 – 0.0018)	0.05 (0.002)	
	Runout	-	0.05 (0.002)	
Piston, piston rings	Piston O.D. at 11 (0.4) from bottom	64.970 – 64.990 (2.5579 – 2.5587)	64.90 (2.555)	
	Piston pin bore I.D.	17.002 – 17.008 (0.6694 – 0.6696)	17.02 (0.670)	
	Piston pin O.D.	16.994 – 17.000 (0.6691 – 0.6693)	16.98 (0.669)	
	Piston -to piston pin clearance	0.002 – 0.014 (0.0001 – 0.0006)	0.04 (0.002)	
	Piston ring end gap	Top	0.10 – 0.20 (0.004 – 0.008)	0.4 (0.02)
		Second	0.18 – 0.30 (0.007 – 0.012)	0.5 (0.02)
		Oil (side rail)	0.20 – 0.70 (0.008 – 0.028)	1.0 (0.04)
	Piston ring-to-ring groove clearance	Top	0.025 – 0.060 (0.0010 – 0.0024)	0.08 (0.003)
Second		0.015 – 0.050 (0.0006 – 0.0020)	0.08 (0.003)	
Cylinder	I.D.	65.000 – 65.015 (2.5591 – 2.5596)	65.10 (2.563)	
	Out of round	-	0.10 (0.004)	
	Taper	-	0.10 (0.004)	
	Warpage	-	0.10 (0.004)	
Cylinder-to piston clearance		0.010 – 0.045 (0.0004 – 0.0018)	0.10 (0.004)	
Connecting rod small end I.D.		17.016 – 17.034 (0.6699 – 0.6706)	17.04 (0.671)	
Connecting rod-to-piston pin clearance		0.016 – 0.040 (0.0006 – 0.0016)	0.06 (0.002)	



TORQUE VALUES

Connecting rod bearing cap nut
Main journal bolt

25 N·m (2.6 kgf·m, 19 lbf·ft)
26 N·m (2.7 kgf·m, 20 lbf·ft)

Apply oil to the threads and seating surface
Apply oil to the threads and seating surface

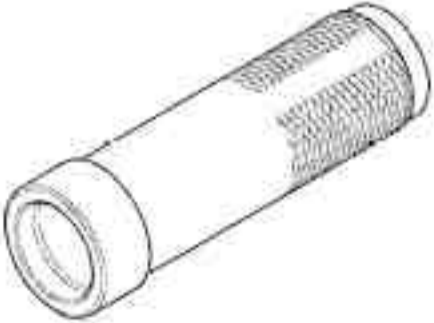
TOOLS

<p>Driver, 40 mm I.D. 07746-0030100</p> 	<p>Attachment, 30 mm I.D. 07746-0030300</p> 
---	--

TROUBLESHOOTING

Cylinder compression is too low, hard to starting or poor performance at low speed

- Leaking cylinder head gasket
- Worn, stuck or broken piston ring
- Worn or damaged cylinder and piston

Cylinder compression too high, overheats or knocks

- Carbon deposits on the cylinder head and/or piston crown

Excessive smoke

- Worn cylinder, piston or piston ring
- Improper installation of piston rings
- Scored or scratched piston or cylinder wall

Abnormal noise

- Worn piston pin or piston pin hole
- Worn connecting rod small end
- Worn cylinder, piston or piston rings
- Worn main journal bearings
- Worn crankpin bearings

Engine vibration

- Excessive crankshaft runout

CRANKSHAFT

Separate the crankcase halves (page 12-5).

SIDE CLEARANCE INSPECTION

Measure the connecting rod side clearance.

SERVICE LIMIT: 0.30 mm (0.012 in)

If the clearance exceeds the service limit, replace the connecting rod.

Recheck and if still out of limit, replace the crankshaft.

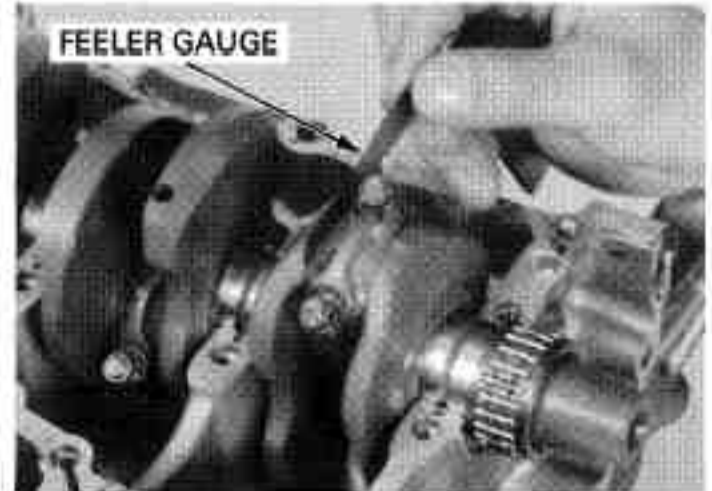

REMOVAL

Be careful not to damage the crankpin, main journal and bearing inserts.

Mark the bearing caps and bearings as you remove them to indicate the correct cylinder for reassembly.

Remove the connecting rod bearing cap nuts and bearing caps.

Tap the side of the cap lightly if the bearing cap is hard to remove.

Remove the crankshaft.

NOTICE

Before removal, position all the pistons at TDC (Top Dead Center) to prevent damaging the crankpin with the connecting rod bolt threads.

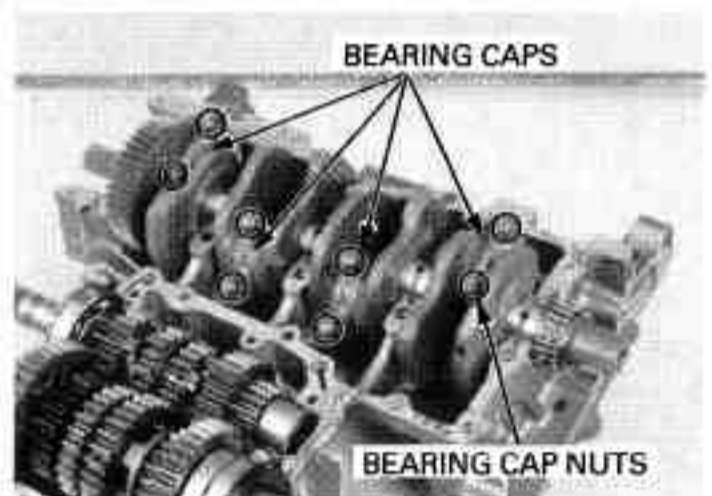

INSPECTION

Hold the crankshaft at both ends.

Set a dial gauge on the center main journal of the crankshaft.

Rotate the crankshaft two revolutions and read the runout.

SERVICE LIMIT: 0.05 mm (0.002 in)

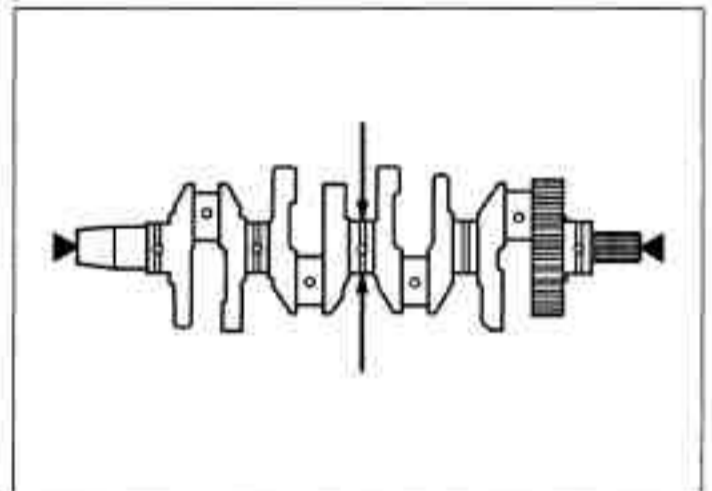

STARTER CLUTCH NEEDLE BEARING REPLACEMENT

To protect the crankshaft main journal from the bearing puller claws, cover the mainshaft journal properly; worn main journal bearings are usable protectors.

Remove the needle bearing with a commercially available universal bearing puller.

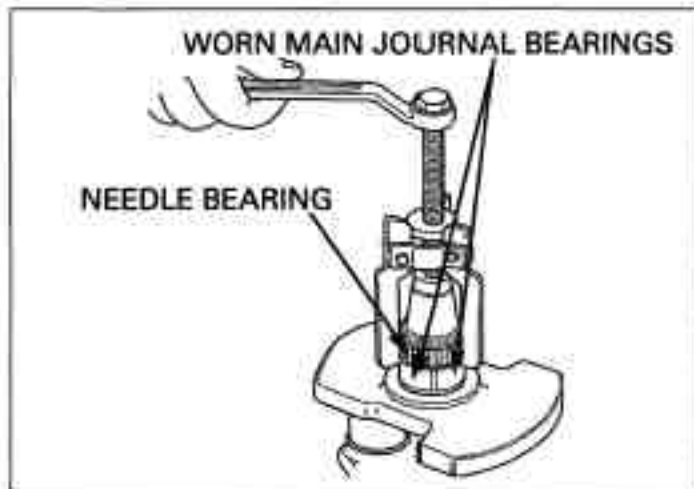

Press a new needle bearing onto the crankshaft using a hydraulic press and special tools.

TOOLS:

Driver, 40 mm I.D.

07746-0030100

Attachment, 30 mm I.D.

07746-0030300

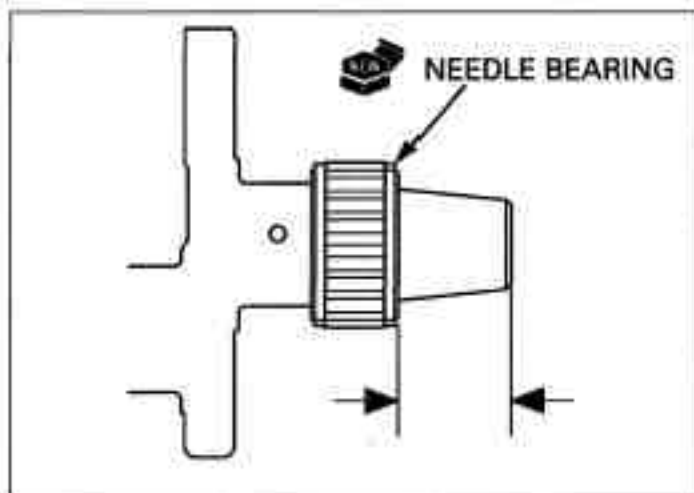

INSTALLATION

Apply molybdenum oil solution to the main journal bearing sliding surfaces on the upper crankcase and the crankpin bearing sliding surfaces on the connecting rods.

Apply molybdenum oil solution to the thrust surfaces of the crankshaft.



Lower all pistons to the top dead center to avoid damaging the crankpin by the connecting rod bolts. Carefully install the crankshaft onto the upper crankcase.

NOTICE

Position all the pistons at TDC (Top Dead Center) to prevent damaging the crankpin with the connecting rod bolt threads.

Set the connecting rods onto the crankpins.

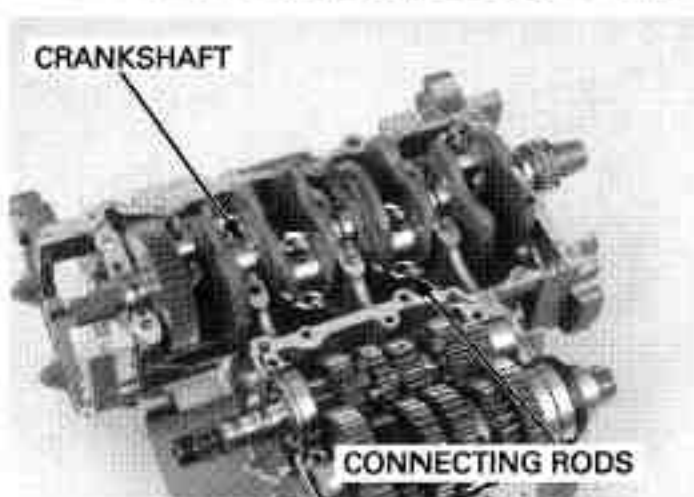

Apply molybdenum oil solution to the crankpin bearing sliding surfaces on the bearing caps. Install the bearing caps by aligning the I.D. code on the connecting rod and bearing cap. Be sure each part is installed in its original position, as noted during removal.

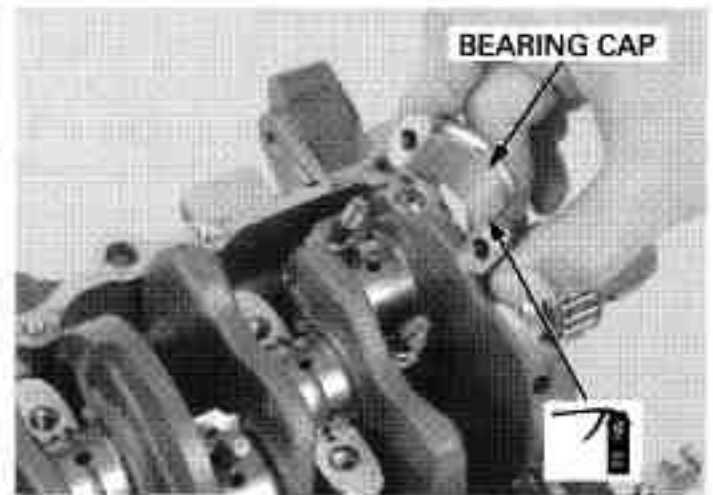

Apply oil to the bearing cap nut threads and seating surfaces and install the cap nuts. Tighten the nut in 2 or 3 steps and torque them.

TORQUE: 25 N·m (2.6 kgf·m, 19 lbf·ft)

Assemble the crankcase halves (page 12-14).

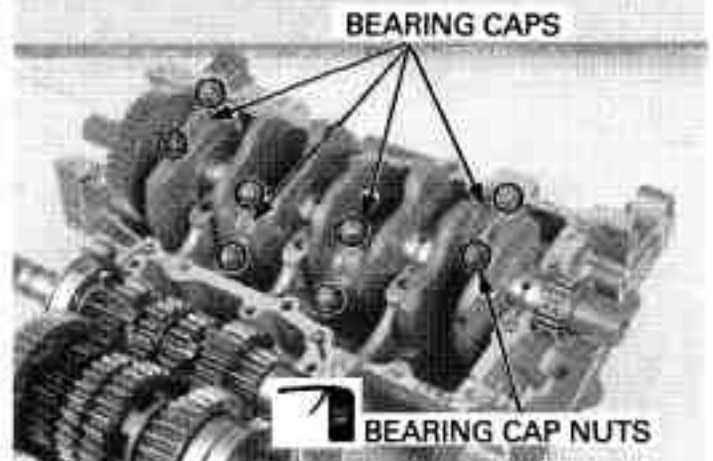

MAIN JOURNAL BEARING

NOTICE

Do not interchange the bearing inserts. They must be installed in their original locations or the correct bearing oil clearance may not be obtained, resulting in engine damage.

Remove the crankshaft (page 13-5).

BEARING INSPECTION

Inspect the main journal bearing inserts on the upper and lower crankcase for unusual wear or peeling.

Check the bearing tabs for damage.



CRANKSHAFT/PISTON/CYLINDER

Do not rotate the crankshaft during inspection.

OIL CLEARANCE INSPECTION

Clean off any oil from the bearing inserts and main journals.
Install the crankshaft onto the upper crankcase.
Put a strip of plastigauge lengthwise on each main journal avoiding the oil hole.

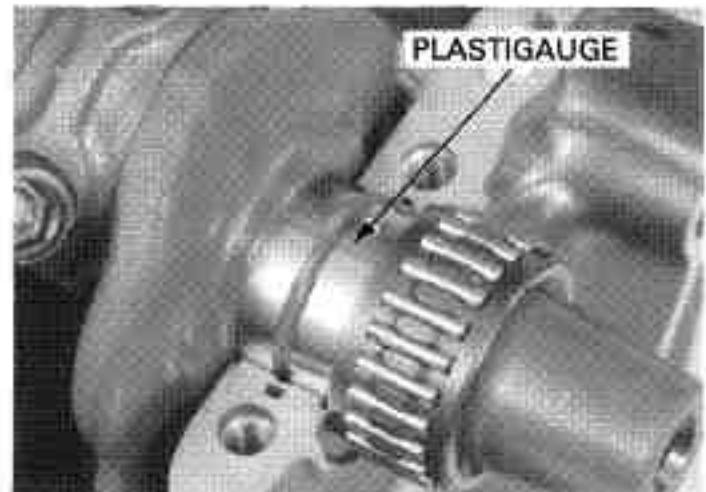

Install the dowel pins and oil orifices.
Carefully install the lower crankcase on the upper crankcase.
Apply engine oil to the main journal 8 mm bolt threads and seating surfaces and install them.
Tighten the 8 mm bolts in a crisscross pattern in 2 or 3 steps.

TORQUE: 26 N·m (2.7 kgf·m, 20 lbf·ft)

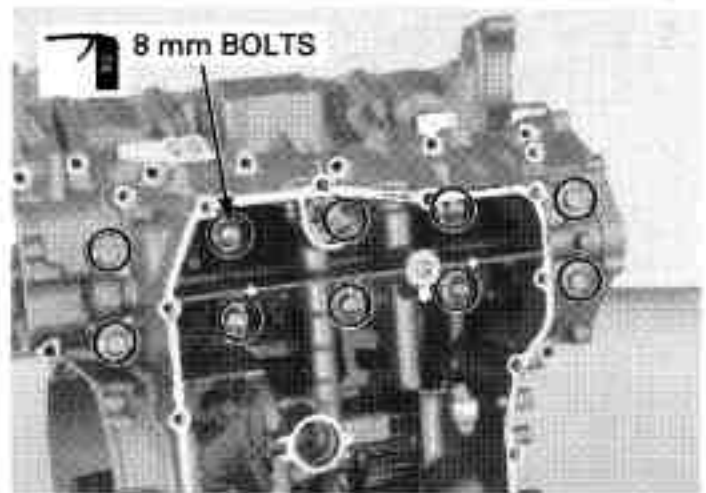

Remove the 8 mm bolts and lower crankcase.
Measure the compressed plastigauge at its widest point on each main journal to determine the oil clearance.

SERVICE LIMIT: 0.05 mm (0.002 in)

If main bearing clearance exceeds the service limit, select the correct replacement bearings.

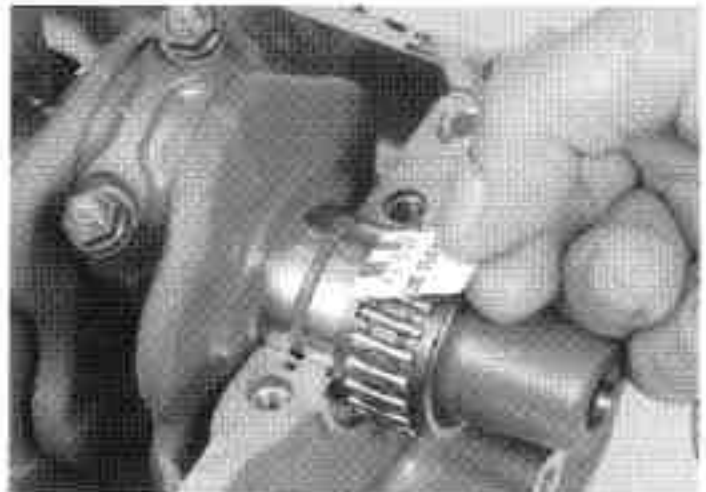

Letters (A, B or C) on the left side of upper crankcase are the codes for the bearing support I.D.s from left to right.

BEARING SELECTION

Record the crankcase bearing support I.D. code letters from the pad on the left side of the upper crankcase as shown.

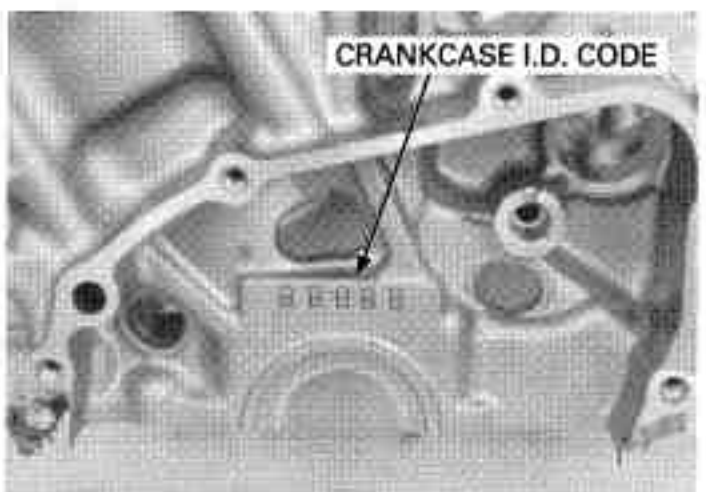

Numbers (1 or 2) on the crank weight are the codes for the main journal O.D.s from left to right.

Record the corresponding main journal O.D. code numbers from the crank weight.

Cross reference the main journal and bearing support codes to determine the replacement bearing color code.

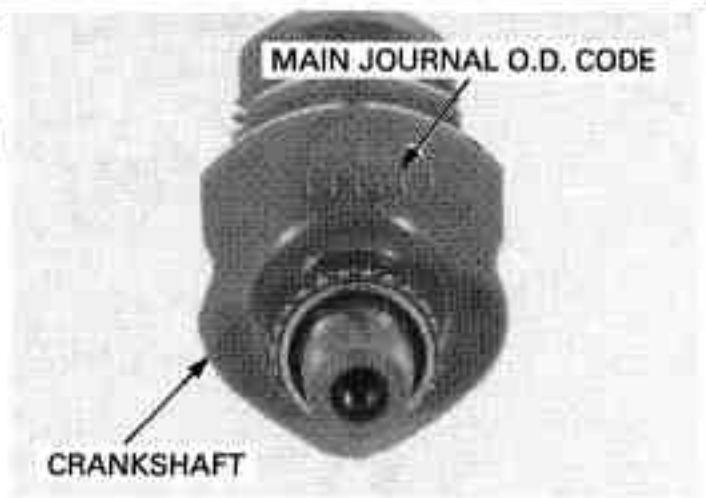

MAIN JOURNAL BEARING SELECTION TABLE:

		BEARING SUPPORT I.D.CODE		
		A	B	C
		36.000 – 36.007 mm (1.4173 – 1.4176 in)	33.007 – 33.014 mm (1.4176 – 1.4179 in)	33.014 – 33.021 mm (1.4179 – 1.4181 in)
MAIN JOURNAL O.D. CODE	1	32.933 – 33.000 mm (1.2989 – 1.2992 in)	D (Pink)	C (Yellow)
	2	32.986 – 32.993 mm (1.2986 – 1.2989 in)	C (Yellow)	B (Green)
				B (Green)
				A (Brown)

BEARING THICKNESS:

- A (Brown) Thick
- B (Green):
- C (Yellow)
- D (Pink) Thin

NOTICE

After selecting new bearings, recheck the clearance with a plastigauge. Incorrect clearance can cause severe engine damage.

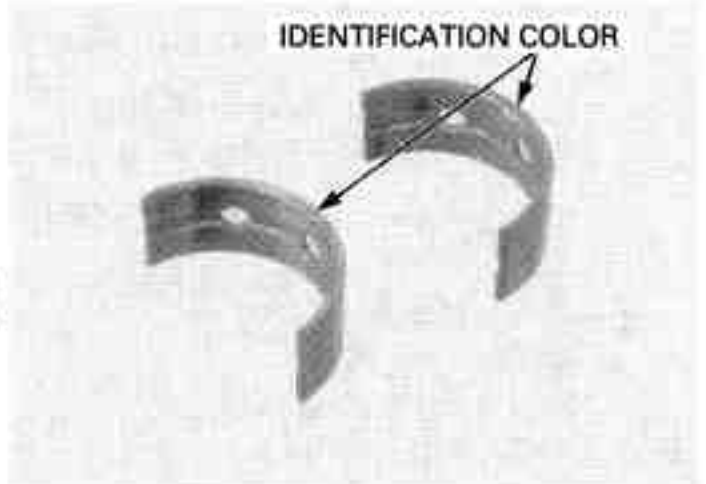

BEARING INSTALLATION

Clean the bearing outer surfaces and crankcase bearing supports. Install the main journal bearing inserts onto the crankcase bearing supports, aligning each tab with each grooves.

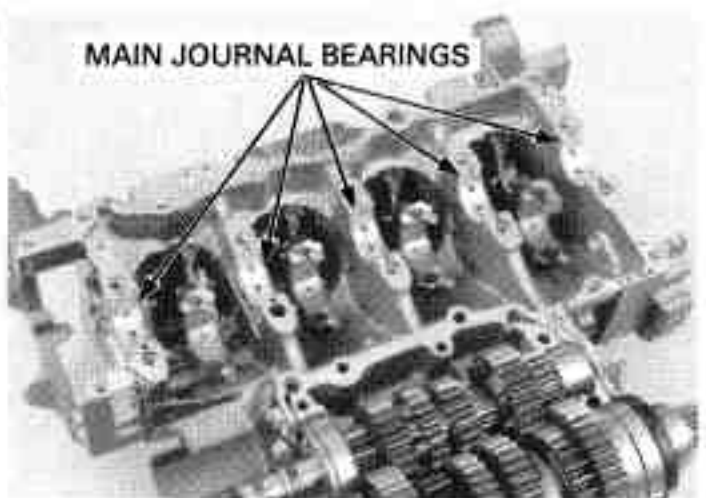

CRANKPIN BEARING

NOTICE

Do not interchange the bearing inserts. They must be installed in their original locations or the correct bearing oil clearance may not be obtained, resulting in engine damage.

Remove the crankshaft (page 13-5).

BEARING INSPECTION

Check the bearing inserts for unusual wear or peeling.

Check the bearing tabs for damage.

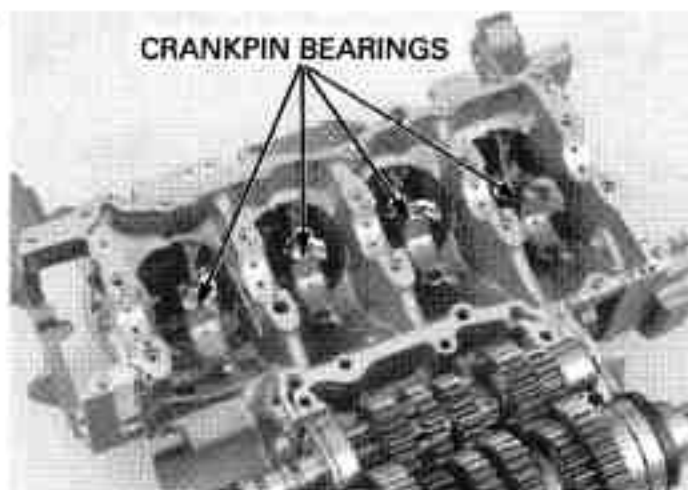

OIL CLEARANCE INSPECTION

Clean off any oil from the bearing inserts and crankpin.

Carefully install the crankshaft onto the upper crankcase.

Set the connecting rods onto the crankpin.

Put a strip of plastigauge lengthwise on the crankpin avoiding the oil hole.



Carefully install the bearing caps by aligning the I.D. code.

Apply engine oil to the connecting rod bearing cap nut threads and seating surfaces and install them.

Tighten the cap nuts in 2 or 3 steps.

TORQUE: 25 N·m (2.6 kgf·m, 19 lbf·ft)



Remove the nuts and bearing cap.
Measure the compressed plastigauge at its widest point on the crankpin to determine the oil clearance.

SERVICE LIMIT: 0.06 mm (0.002 in)

If the oil clearance exceeds the service limit, select the correct replacement bearings.

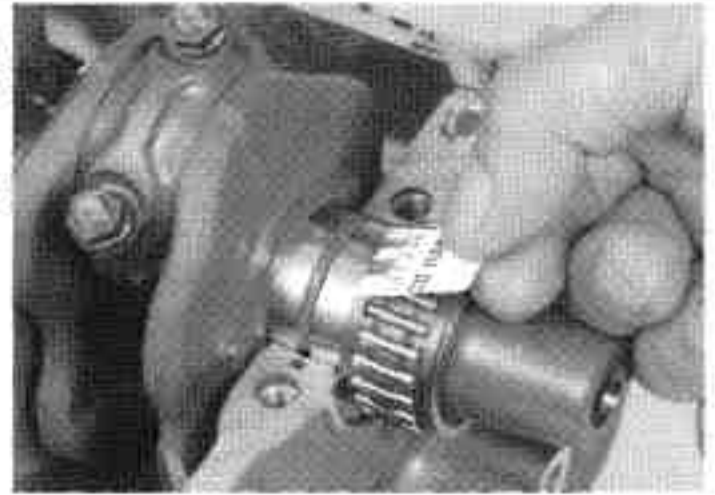

BEARING SELECTION

Numbers (1 or 2) on the connecting rods are the codes for the connecting rod I.D.

Record the connecting rod I.D. code number (1 or 2) or measure the I.D. with the bearing cap installed without bearing inserts.

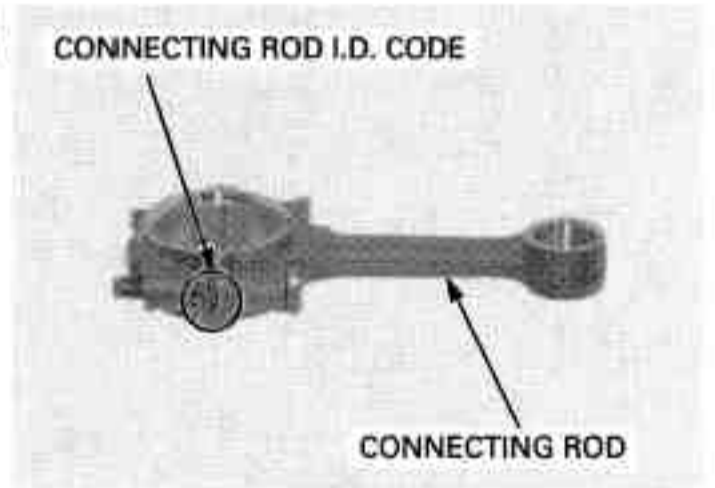

Letters (A or B) on the crank weight are the codes for the crankpin O.D.s from left to right.

If you are replacing the crankshaft, record the corresponding crankpin O.D. code number (A or B).

If you are reusing the crankshaft, measure the crankpin O.D. with the micrometer.

Cross-reference the crankpin and rod codes to determine the replacement bearing color.

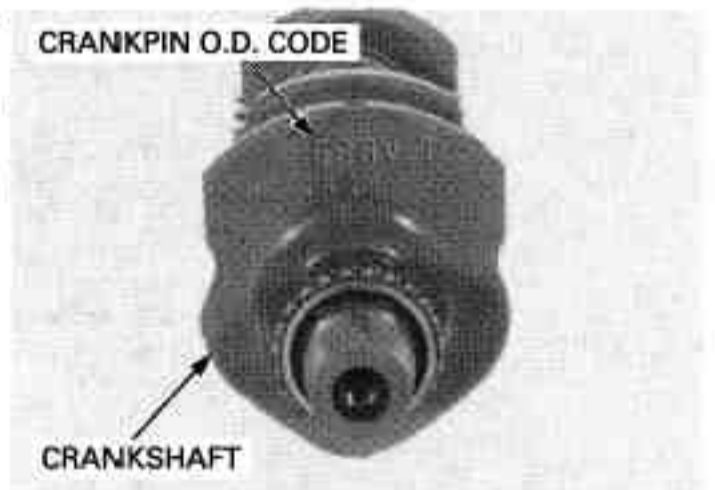

CRANKPIN BEARING SELECTION TABLE:

			Connecting ROD I.D.CODE	
			1	2
			34.000 – 34.008 mm (1.3386 – 1.3389 in)	34.008 – 34.016mm (1.3389 – 1.3392 in)
CRANKPIN O.D. CODE	A	31.492 – 31.500 mm (1.2398 – 1.2402 in)	C (Yellow)	B (Green)
	B	31.484 – 31.492 mm (1.2395 – 1.2398 in)	B (Green)	A (Brown)

BEARING THICKNESS:

A (Brown) Thick

B (Green):

C (Yellow) Thin

NOTICE

After selecting new bearings, recheck the clearance with a plastigauge. Incorrect clearance can cause severe engine damage.

BEARING INSTALLATION

Clean the bearing outer surfaces, bearing cap and connecting rod.

Install the crankpin bearing inserts onto the bearing cap and connecting rod, aligning each tab with each groove.

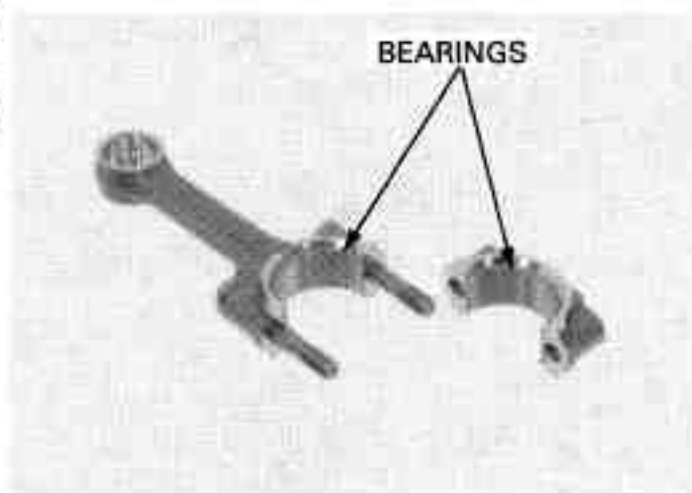
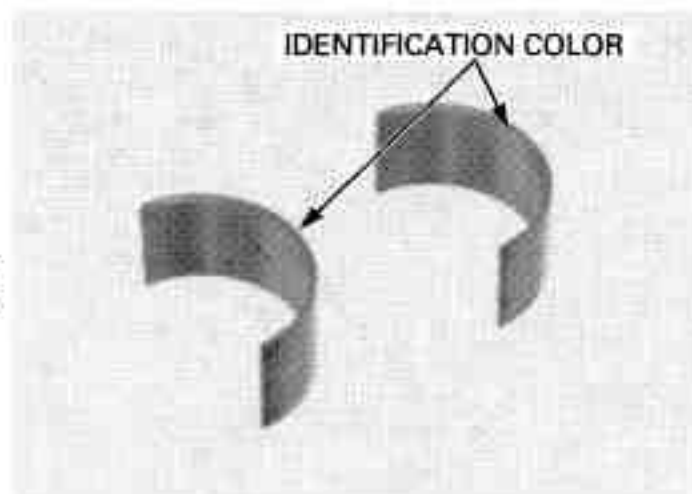

PISTON/CYLINDER

PISTON/CONNECTING ROD REMOVAL

NOTICE

- This motorcycle is equipped with aluminum cylinder sleeves. Before piston removal, place a clean shop towel around the connecting rod to prevent damaging the cylinder sleeve.
- Do not try to remove the connecting rod/piston assembly from the bottom of the cylinder; the assembly will get stuck in the gap between the cylinder liner and the upper crankcase.
- Do not interchange the bearing inserts. They must be installed in their original locations or the correct bearing oil clearance may not be obtained, resulting in engine damage.

Mark the all the parts as you remove them to indicate the correct cylinder for reassembly.

Remove the nuts and connecting rod bearing cap.

Remove the crankshaft (page 13-5).

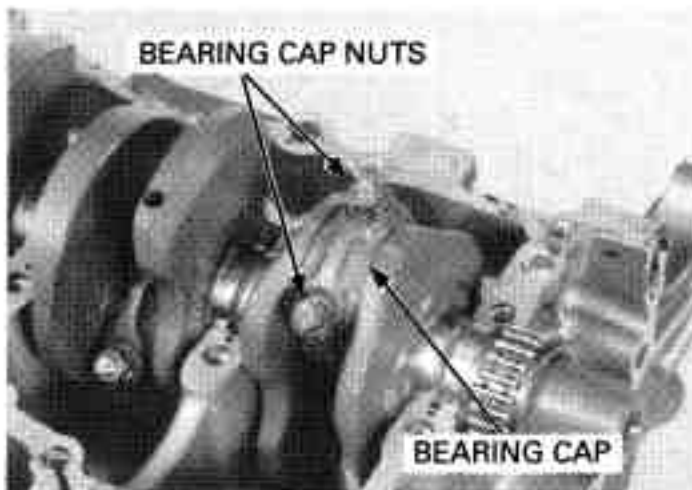

Remove the piston/connecting rod assembly from the top of the cylinder.

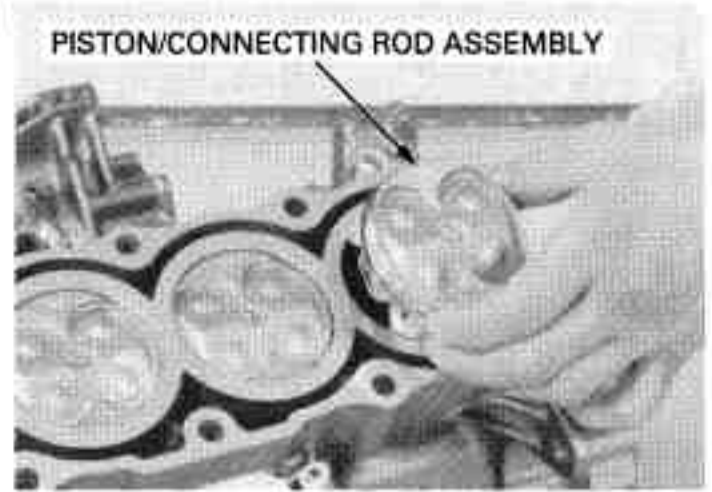

PISTON REMOVAL

Remove the piston pin clip with pliers. Push the piston pin out of the piston and connecting rod, and remove the piston.

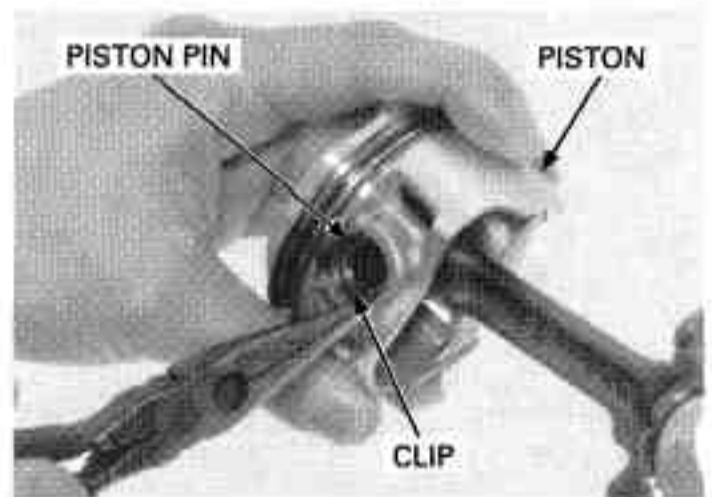

PISTON DISASSEMBLY

Do not damage the piston ring by spreading the ends too far.

Spread each piston ring and remove it by lifting up at a point opposite the gap.

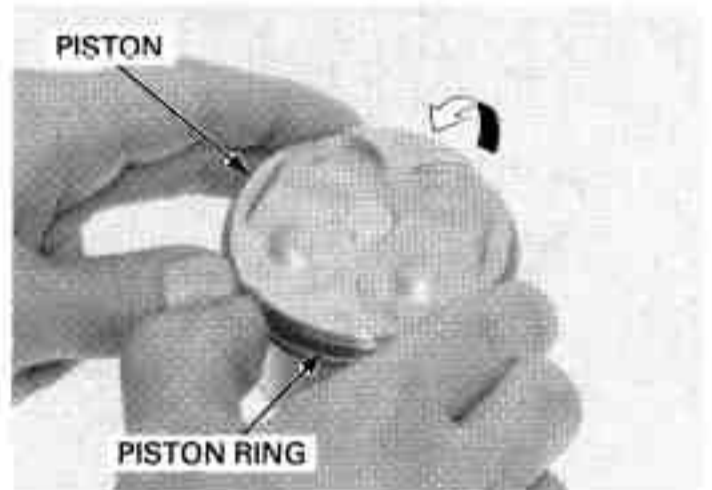

Clean carbon deposits from the ring grooves with a ring that will be discarded. Never use a wire brush; it will scratch the groove.

Remove any carbon deposits from the piston ring grooves.

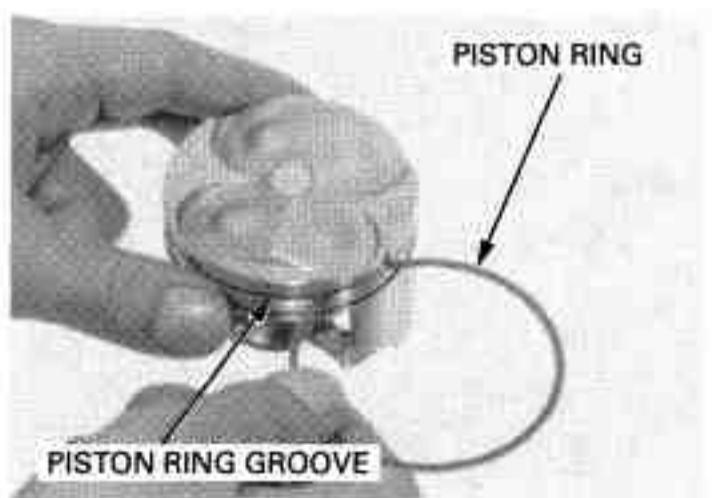

CRANKSHAFT/PISTON/CYLINDER

PISTON INSPECTION

Measure the diameter of the piston at 11 mm (0.4 in) from the bottom and 90 degrees to the piston pin hole.

SERVICE LIMIT: 64.90 mm (2.555 in)

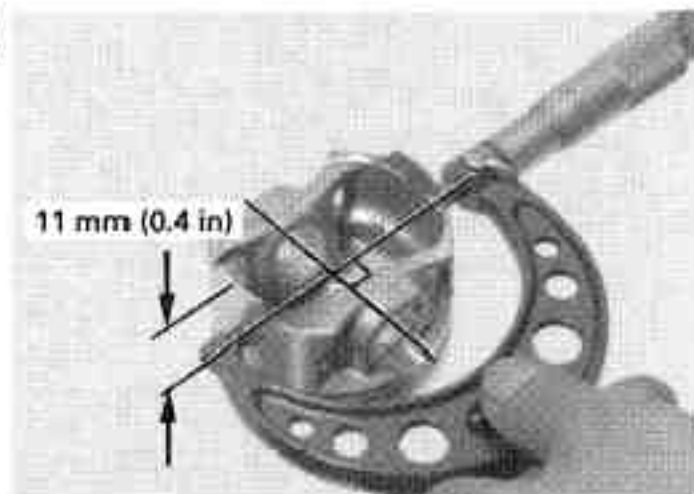

Temporarily install the piston rings to their proper position with the mark facing up.

Measure the piston ring-to-ring groove clearance with the rings pushed into the grooves.

SERVICE LIMITS:

Top/second: 0.08 mm (0.003 in)

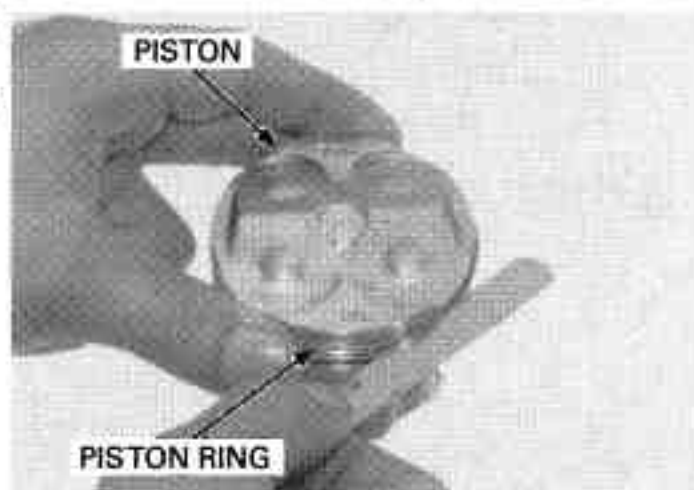

Insert the piston ring squarely into the bottom of the cylinder and measure the ring end gap.

SERVICE LIMITS:

Top: 0.4 mm (0.02 in)

Second: 0.5 mm (0.02 in)

Oil (side rail): 1.0 mm (0.04 in)



Measure the piston pin bore.

SERVICE LIMIT: 17.02 mm (0.670 in)

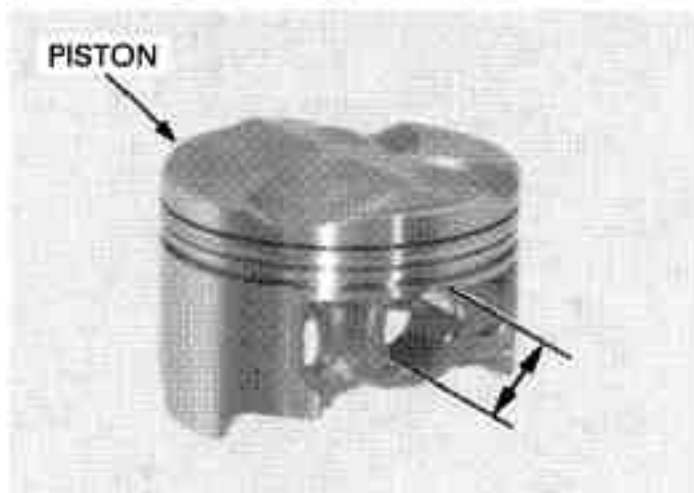

Measure the O.D. of the piston pin.

SERVICE LIMIT: 16.98 mm (0.669 in)

Calculate the piston-to-piston pin clearance.

SERVICE LIMIT: 0.04 mm (0.002 in)

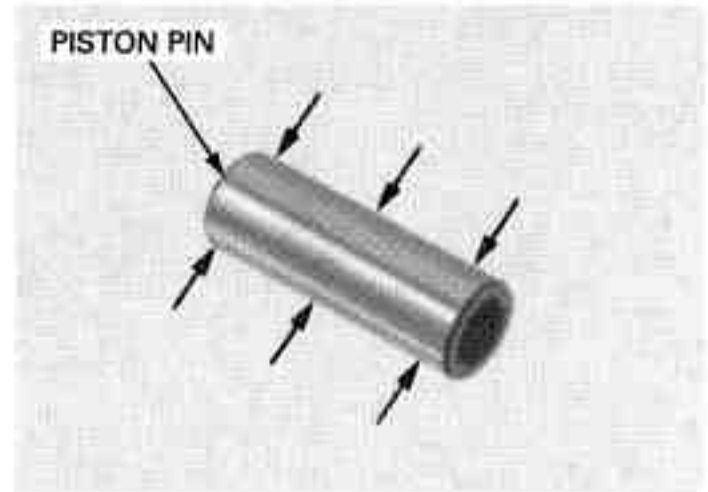

CONNECTING ROD INSPECTION

Measure the connecting rod small end I.D.

SERVICE LIMIT: 17.04 mm (0.671 in)

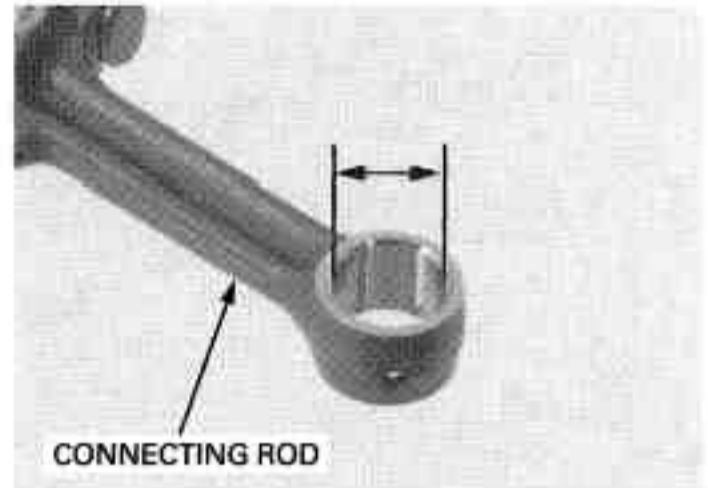

CYLINDER INSPECTION

Inspect the cylinder bore for wear or damage.
Measure the cylinder I.D. in X and Y axis at three levels.
Take the maximum reading to determine the cylinder wear.

SERVICE LIMIT: 65.10 mm (2.563 in)

Calculate the piston-to-cylinder clearance.
Take a maximum reading to determine the clearance.
Refer procedures for measurement of the piston O.D (page 13-14).

SERVICE LIMIT: 0.10 mm (0.004 in)

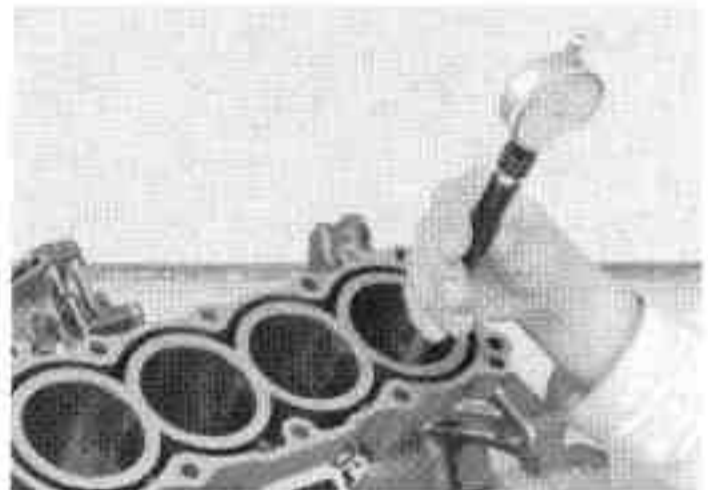

Calculate the taper and out of round at three levels in X and Y axis, Take the maximum reading to determine them.

SERVICE LIMITS:

Taper: 0.10 mm (0.004 in)

Out of round: 0.10 mm (0.004 in)

The cylinder must be rebored and an oversize piston fitted if the service limits are exceeded.

The following oversize pistons are available:

0.25 mm (0.010 in)

0.50 mm (0.019 in)

0.75 mm (0.030 in)

1.00 mm (0.039 in)

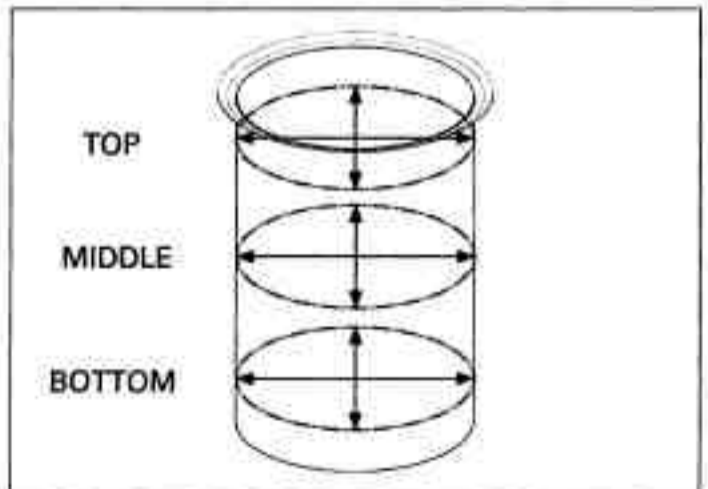

The piston to cylinder clearance for the oversize piston must be: 0.015 – 0.050 mm (0.0006 – 0.0020 in).

CRANKSHAFT/PISTON/CYLINDER

Inspect the top of the cylinder for warpage.

SERVICE LIMIT: 0.10 mm (0.004 in)

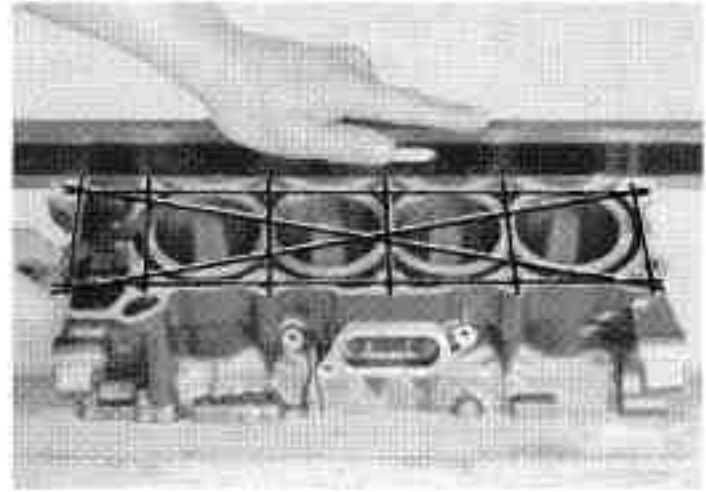

PISTON ASSEMBLY

Carefully install the piston rings into the piston ring grooves with their marking facing up.

- Apply oil to the piston rings.
- Avoid piston and piston ring damage during installation.
- Install the piston rings with the marking facing up.
- Do not mix the top and second rings; top ring is narrower than the second ring in width.

Stagger the piston ring end gaps 120° apart from each other.

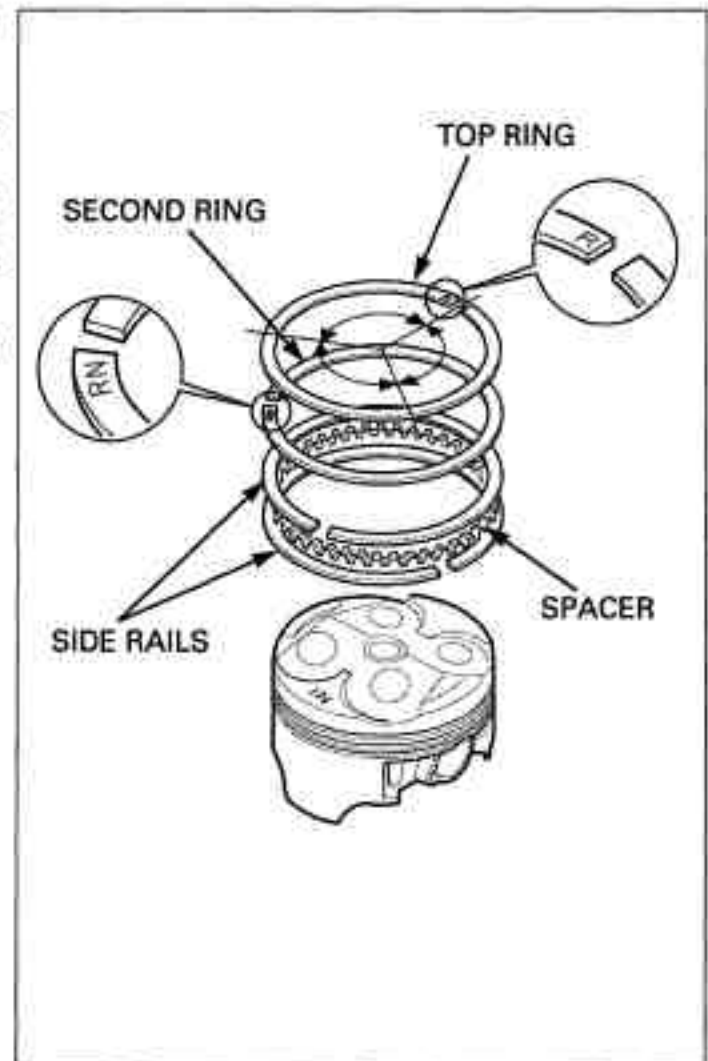

PISTON INSTALLATION

Apply molybdenum oil solution to the connecting rod small end inner surfaces and piston pin outer surfaces.

Apply engine oil to the piston pin outer surfaces.

Install the piston pin into the piston and connecting rod.

Install the piston so that the "IN" mark facing the same direction as the oil hole in the connecting rod.

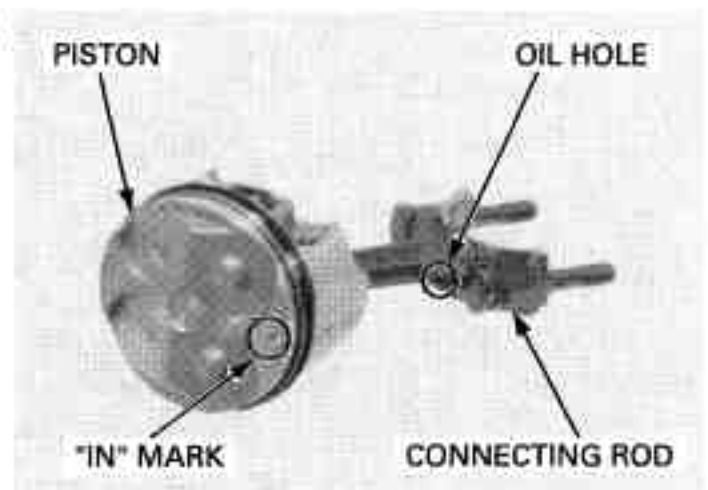

Install new piston pin clips into the grooves of the piston pin hole.

- Make sure that the piston pin clips seated securely.
- Do not align the piston pin clip end gap with the piston cut-out.

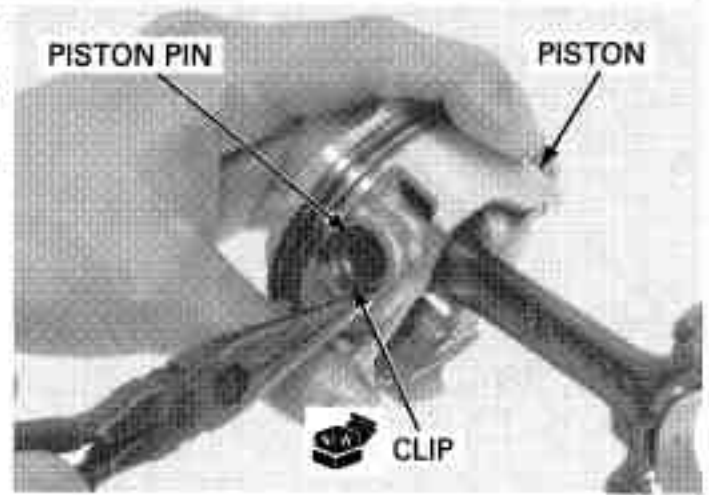

Apply engine oil to the cylinder wall, piston and piston rings.

Install the piston/connecting rod assembly into the cylinder using a commercially available piston ring compressor tool.

NOTICE

- While installing the piston, being careful not to damage the top surface of the cylinder, especially around the cylinder bore.
- Be careful not to damage the cylinder sleeve and crankpin with the connecting rod bolt threads.

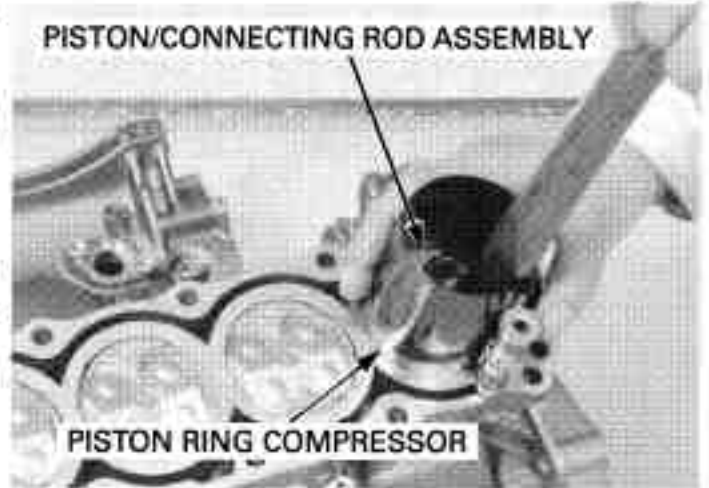

Make sure ring compressor tool sits flush with top surface of the cylinder.

Use the handle of a plastic hammer to tap the piston into the cylinder.

Make sure the piston/connecting rod assembly with the piston "IN" mark facing to the intake side.

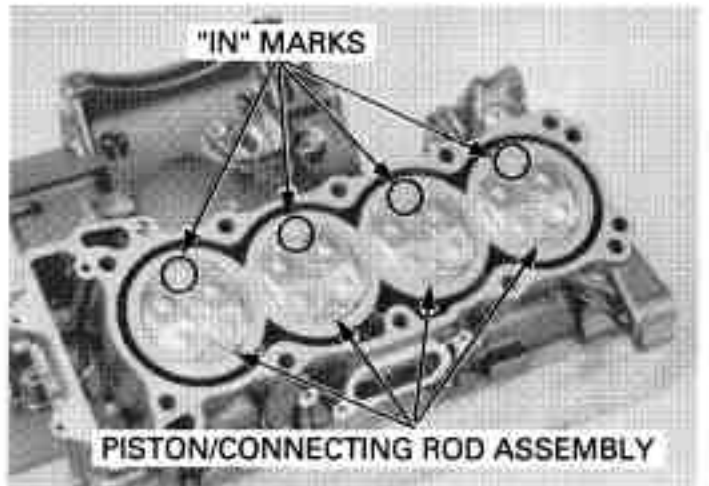

Apply molybdenum oil solution to the crankpin bearing surfaces.

Install the crankshaft (page 13-6).

Install the bearing cap.

Insure that the marks on the caps are aligned with the marks on the connecting rods.

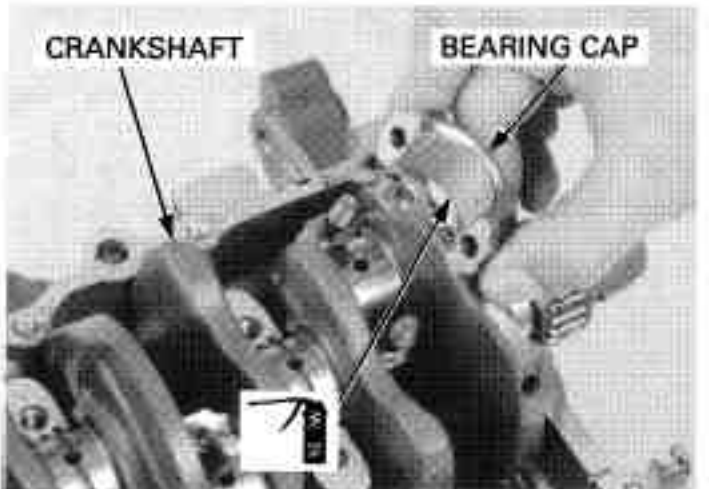

CRANKSHAFT/PISTON/CYLINDER

Apply oil to the connecting rod nut threads and seating surfaces.

Install the connecting rod nuts and tighten the nuts gradually and alternately, then tighten them to the specified torque.

TORQUE: 25 N·m (2.6 kgf·m, 19 lbf·ft)

Install the removed parts in the reverse order of removal.

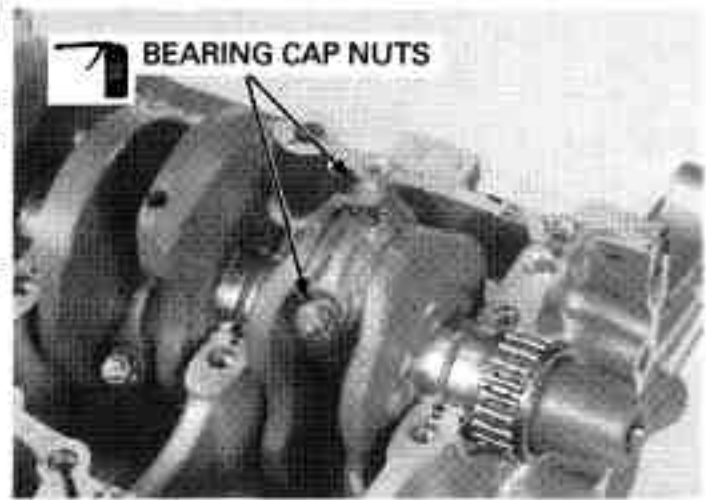

14. FRONT WHEEL/SUSPENSION/STEERING

COMPONENT LOCATION	14-2	FRONT WHEEL	14-15
SERVICE INFORMATION	14-4	FORK	14-21
TROUBLESHOOTING	14-7	STEERING STEM	14-41
HANDLEBAR	14-8		

FRONT WHEEL/SUSPENSION/STEERING

COMPONENT LOCATION

'04 model:

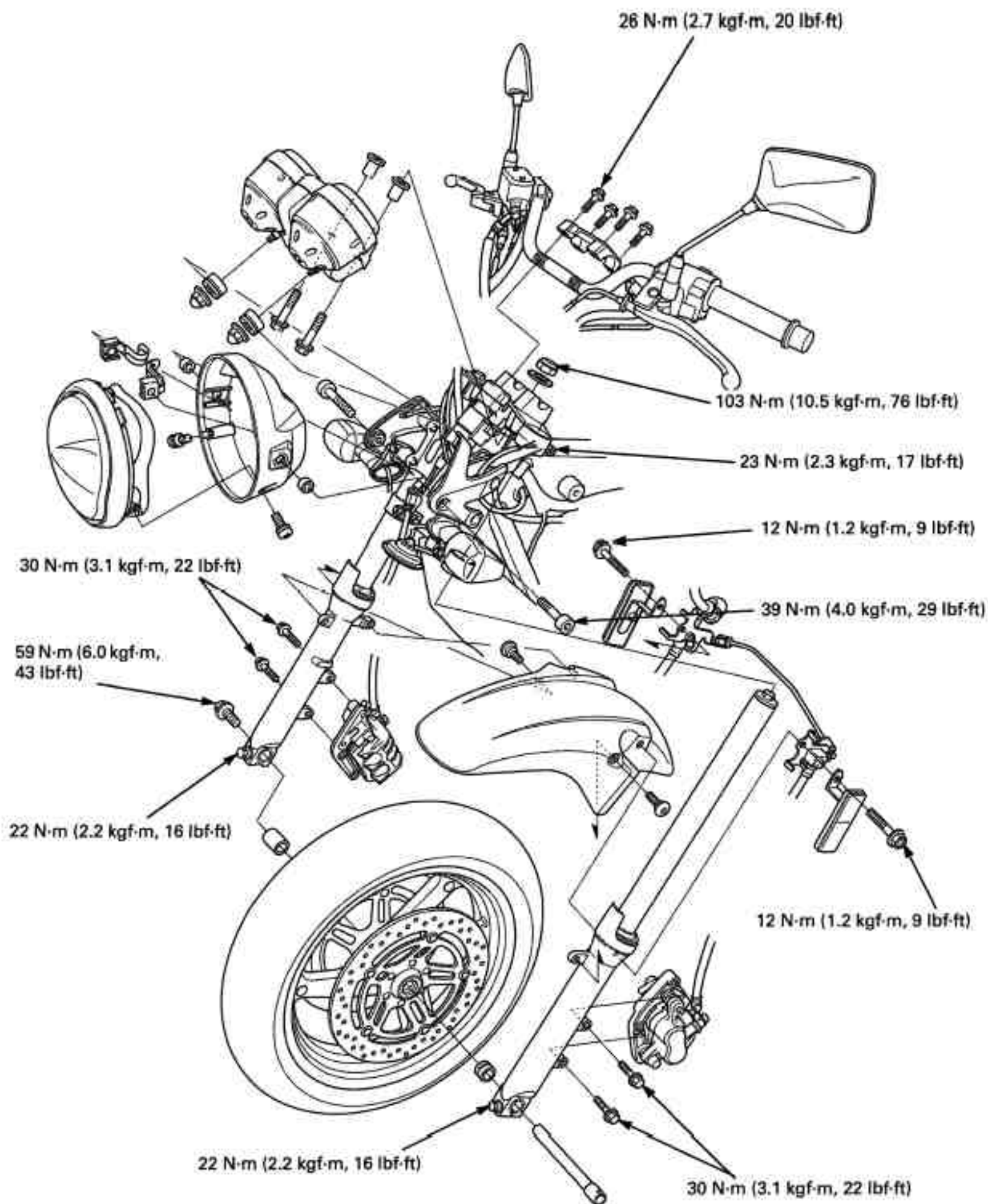

FRONT WHEEL/SUSPENSION/STEERING

After '04 model:

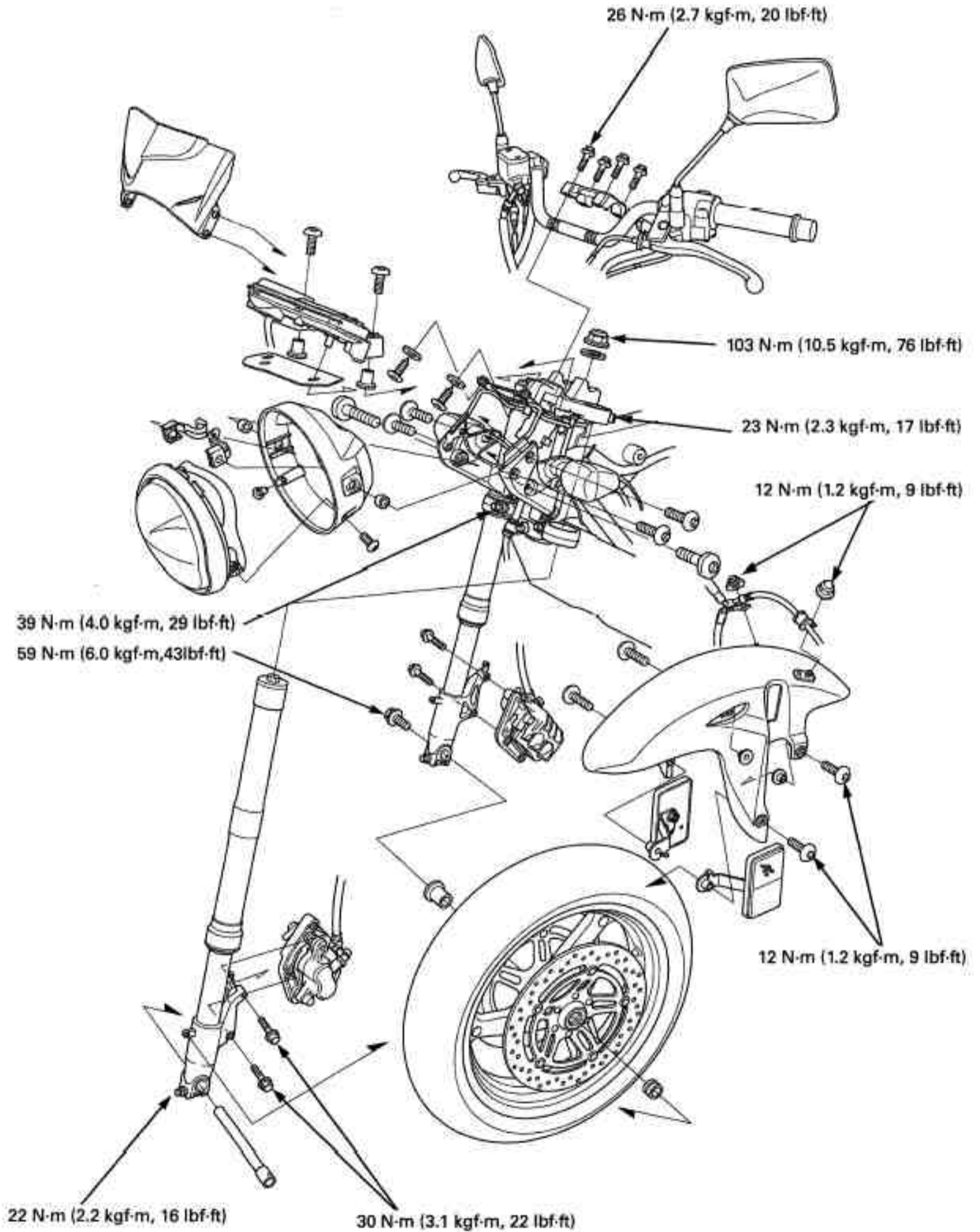

FRONT WHEEL/SUSPENSION/STEERING

SERVICE INFORMATION

GENERAL

- When servicing the front wheel, fork or steering stem, support the motorcycle using a safety stand or hoist.
- A contaminated brake disc or pad reduces stopping power. Discard contaminated pads and clean a contaminated disc with a high quality brake degreasing agent.
- After the front wheel installation, check the brake operation by applying the brake lever.
- Refer to the brake system information (page 16-4).
- Use only tires marked "TUBELESS" and tubeless valves on rim marked "TUBELESS TIRE APPLICABLE".

SPECIFICATIONS ('04 model)









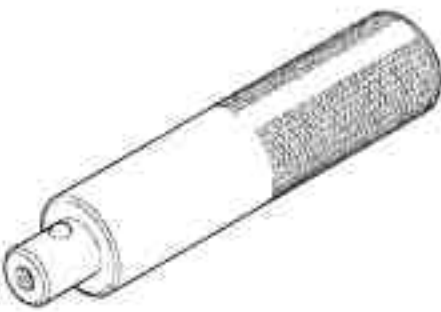

Unit: mm (in)

ITEM		STANDARD	SERVICE LIMIT
Minimum tire tread depth		-	1.5 (0.06)
Cold tire pressure	Driver only	250 kPa (2.50 kgf/cm ² , 36 psi)	-
	Driver and passenger	250 kPa (2.50 kgf/cm ² , 36 psi)	-
Axle runout		-	0.2 (0.01)
Wheel rim runout	Radial	-	2.0 (0.08)
	Axial	-	2.0 (0.08)
Wheel balance weight		-	60 g (2.1oz) max.
Fork ('04 model)	Spring free length	338.3 (13.32)	331.5 (13.05)
	Pipe runout	-	0.20 (0.008)
	Recommended fork fluid	Pro Honda suspension fluid SS-8	-
	Fluid level	140 (5.5)	-
	Fluid capacity	447 ± 2.5 cm ³ (15.1 ± 0.08 US oz, 15.7 ± 0.09 Imp oz)	-
Fork (After '04 model)	Spring free length	281.6 (11.09)	276.0 (10.9)
	Pipe runout	-	0.20 (0.008)
	Recommended fork fluid	Pro Honda suspension fluid SS-8	-
	Fluid level	77 (3.3)	-
	Fluid capacity	483 ± 2.5 cm ³ (16.36 ± 0.08 US oz, 17.00 ± 0.09 Imp oz)	-
Steering head bearing pre-load		0.9 - 1.3 kgf (2.0 - 2.9 lbf)	-





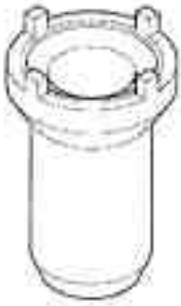
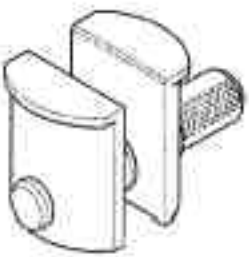
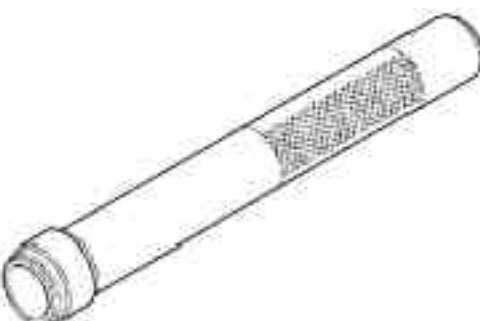

TORQUE VALUES

Handlebar holder bolt	26 N·m (2.7 kgf·m, 20 lbf·ft)	
Steering stem nut	103 N·m (10.5 kgf·m, 76 lbf·ft)	See page 14-44
Steering bearing adjustment nut lock nut	-	See page 14-44
Steering bearing adjustment nut	-	See page 14-44
Fork top bridge pinch bolt	23 N·m (2.3 kgf·m, 17 lbf·ft)	
Fork bottom bridge pinch bolt	39 N·m (4.0 kgf·m, 29 lbf·ft)	
Front axle bolt	59 N·m (6.0 kgf·m, 43 lbf·ft)	
Front axle holder bolt	22 N·m (2.2 kgf·m, 16 lbf·ft)	
Front brake disc mounting bolt	20 N·m (2.0 kgf·m, 14 lbf·ft)	ALOC bolt; replace with a new one
Fork cap	23 N·m (2.3 kgf·m, 17 lbf·ft)	'04 model
Front fork bolt	34 N·m (3.5 kgf·m, 25 lbf·ft)	After '04 model
Fork socket bolt	20 N·m (2.0 kgf·m, 14 lbf·ft)	Apply a locking agent to the threads
Front master cylinder holder bolt	12 N·m (1.2 kgf·m, 9 lbf·ft)	
Front brake caliper mounting bolt	30 N·m (3.1 kgf·m, 22 lbf·ft)	ALOC bolt; replace with a new one
Front brake hose clamp bolt	12 N·m (1.2 kgf·m, 9 lbf·ft)	'04 model
		ALOC bolt; replace with a new one
Front brake hose clamp cap nut	12 N·m (1.2 kgf·m, 9 lbf·ft)	After '04 model
Rearview mirror mounting nut	3.4 N·m (0.35 kgf·m, 2.5 lbf·ft)	

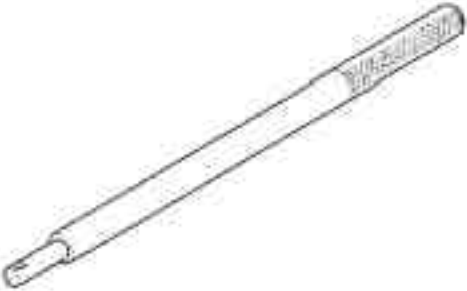
TOOLS

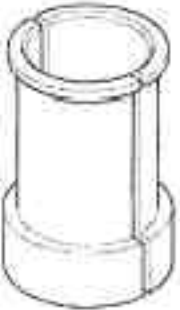
<p>Bearing remover shaft 07GGD-0010100</p>  <p>or 07746-0050100</p>	<p>Bearing remover head, 20 mm 07746-0050600</p> 	<p>Driver 07749-0010000</p> 
<p>Attachment, 42 X 47 mm 07746-0010300</p> 	<p>Attachment, 52 X 55 mm 07746-0010400</p> 	<p>Pilot, 20 mm 07746-0040500</p> 
<p>Slider weight 07947-KA50100</p> 	<p>Oil seal driver attachment 07947-KF00100</p> 	<p>Steering stem socket 07916-3710101</p>  <p>or 07916-3710100 (U.S.A. only)</p>
<p>Ball race remover 07946-3710500</p> 	<p>Steering stem driver 07946-MB00000</p> 	<p>Driver attachment 07953-MJ10100</p>  <p>or Race remover 07953-MJ1000B (U.S.A. only) or 07953-MJ1000A (U.S.A. only)</p>

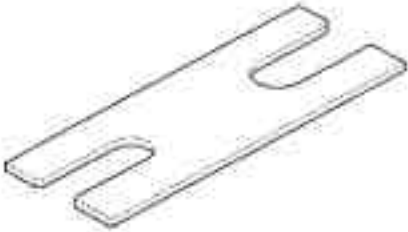
FRONT WHEEL/SUSPENSION/STEERING

<p>Driver handle 07953-MJ10200</p>  A long, thin, cylindrical metal rod with a slightly wider, textured section at one end.	<p>Fork seal driver weight 07KMD-KZ30100</p>  A cylindrical metal component with a wider, flanged top section and a narrower bottom section.	<p>Oil seal driver attachment 07RMD-MW40100</p>  A cylindrical metal component with a wide, flanged top section and a narrower bottom section, similar to the fork seal driver weight but with a different profile.
<p>Spring collar holder 070MF-MBZC110</p>  A metal component consisting of a circular collar with a central hole and two long, thin arms extending from the sides.	<p>Stopper plate 070MF-MBZC130</p>  A flat, rectangular metal plate with two long, thin arms extending from one side, similar to the spring collar holder but with a different shape.	<p>Fork damper holder 070MF-MBZC120</p>  A long, thin, cylindrical metal rod with a slightly wider section at one end.
<p>Fork damper holder attachment 07YMB-MCF1010</p>  A long, thin, cylindrical metal rod with a slightly wider section at one end, similar to the fork damper holder.		

TROUBLESHOOTING

Hard steering

- Steering head bearing adjustment nut too tight
- Faulty or damaged steering head bearings
- Bent steering stem
- Faulty tire
- Insufficient tire pressure

Steers to one side or does not track straight

- Damaged or loose steering head bearings
- Bent forks
- Bent axle
- Bent frame
- Wheel installed incorrectly
- Worn or damaged wheel bearings
- Worn or damaged swingarm pivot bearings

Front wheel wobbling

- Bent rim
- Worn or damaged front wheel bearings
- Faulty tire
- Unbalanced front tire and wheel

Front wheel turns hard

- Faulty front wheel bearing
- Bent front axle
- Front brake drag

Soft suspension

- Insufficient fluid in fork
- Incorrect fork fluid weight
- Weak fork springs
- Insufficient tire pressure

Hard suspension

- Bent fork tubes
- Too much fluid in fork
- Incorrect fork fluid weight
- Clogged fork fluid passage

Front suspension noise

- Insufficient fluid in fork
- Loose fork fasteners

HANDLEBAR

REMOVAL

Remove the rearview mirrors.

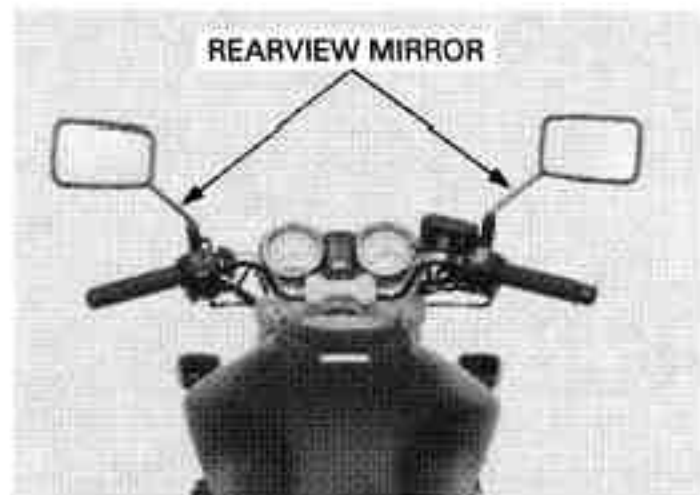

Disconnect the clutch switch wire connectors from the switch.
Remove the clutch lever bracket holder bolts, holder and clutch lever bracket assembly.

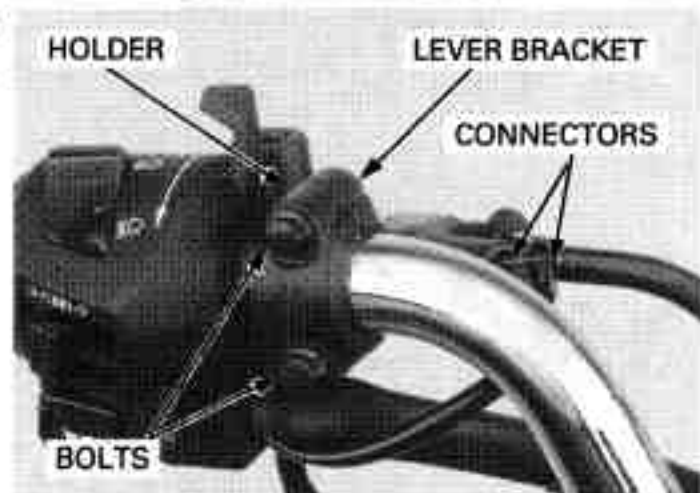

Remove the screws.

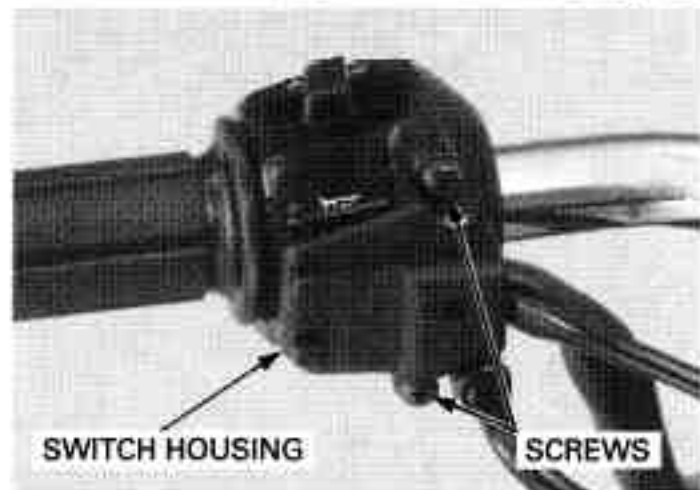

Disconnect the choke cable from the choke lever and remove the left handlebar switch.

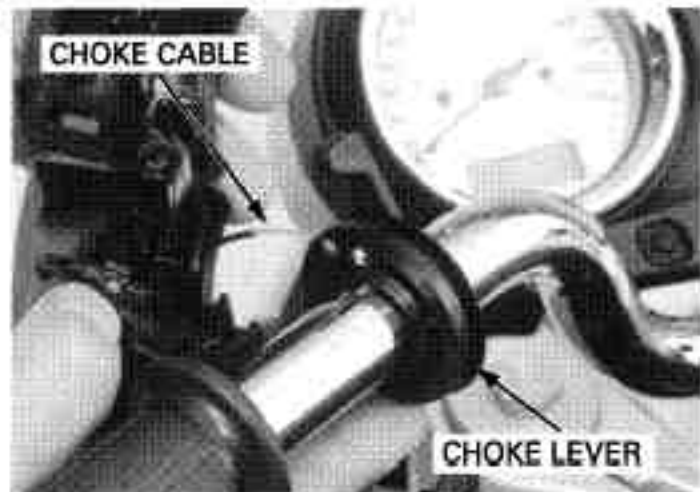

FRONT WHEEL/SUSPENSION/STEERING

Remove the screw and handlebar weight, handlebar grip rubber and choke lever.

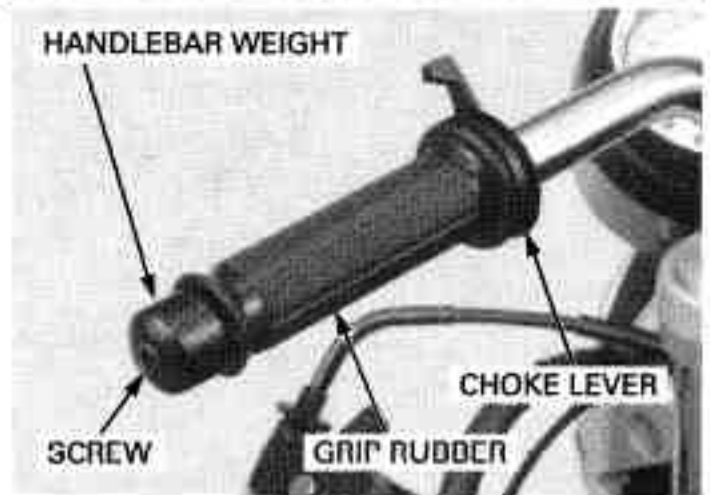

Disconnect the front brake switch wire connectors from the switch.

Keep the brake master cylinder upright to prevent air from entering the hydraulic system.

Remove the master cylinder holder bolts, holder and master cylinder assembly.

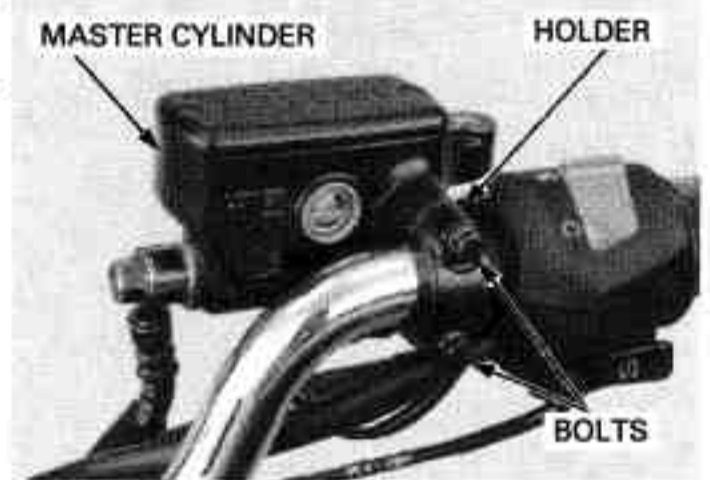

Remove the right handlebar switch/throttle housing screws.

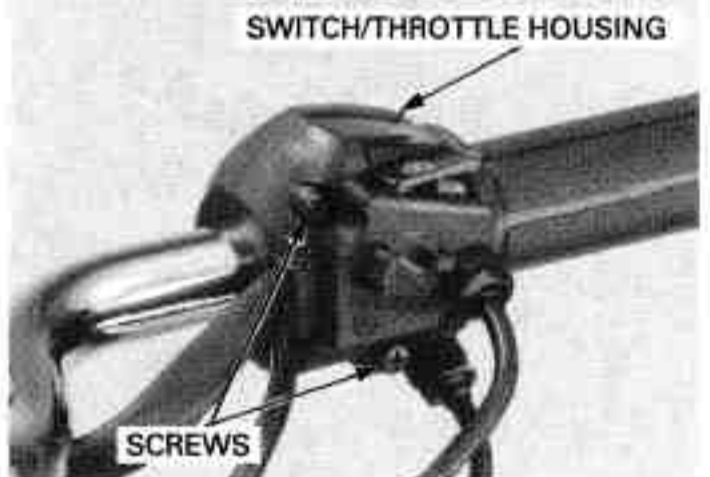

Remove the screw and handlebar weight from the handlebar.

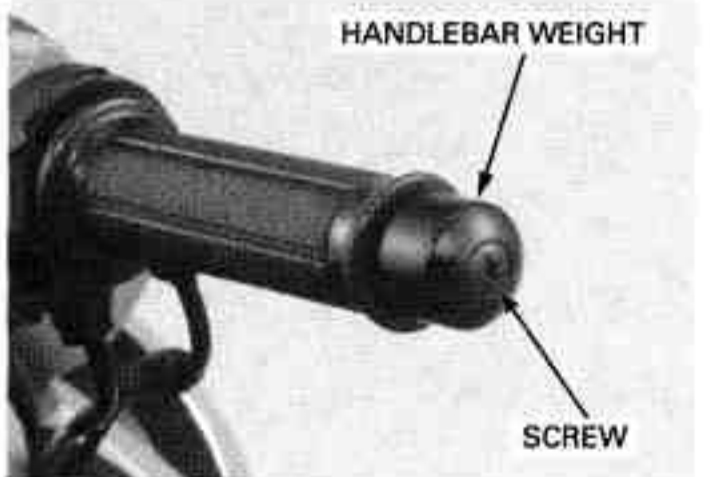

FRONT WHEEL/SUSPENSION/STEERING

Remove the bolts and handlebar holder.
Remove the handlebar.

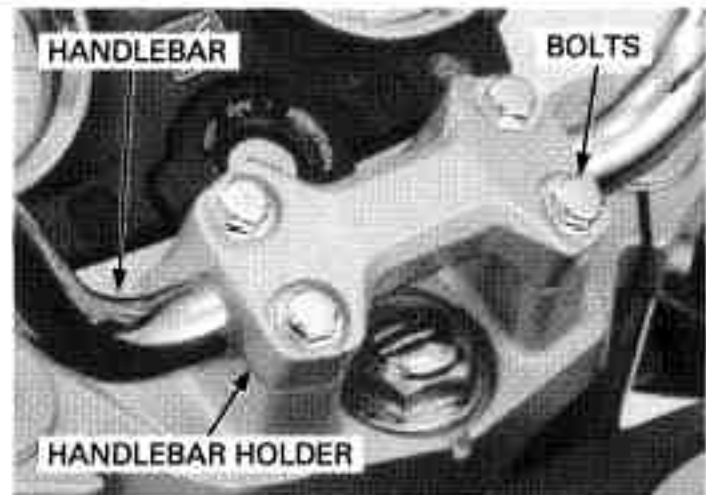

Disconnect the throttle cable ends from the throttle pipe and remove the right handlebar switch/throttle housing.

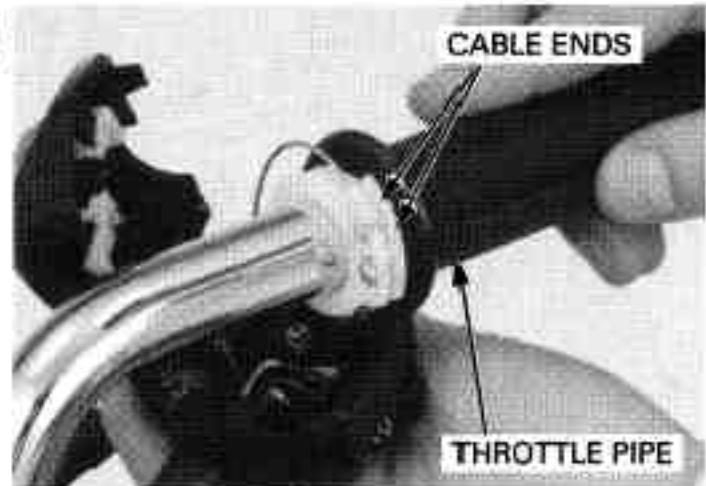

INSTALLATION

Apply grease to the sliding surface of the throttle pipe, then install the throttle pipe onto the handlebar.

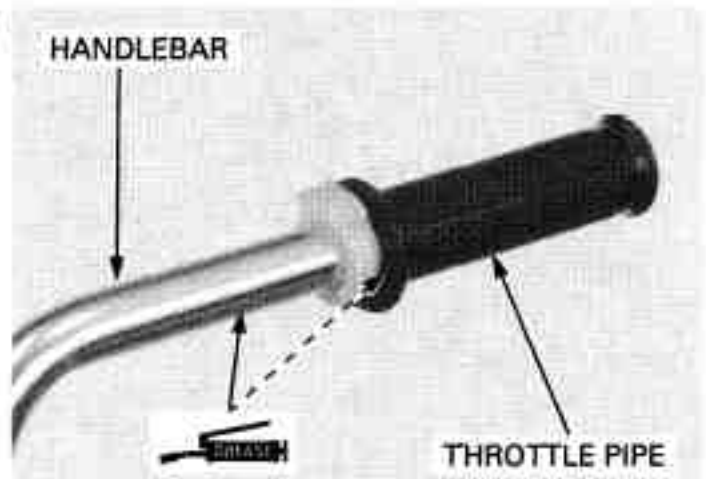

Connect the throttle cable ends to the throttle pipe. Install the right handlebar switch/throttle housing aligning its location pin with the hole in the handlebar.

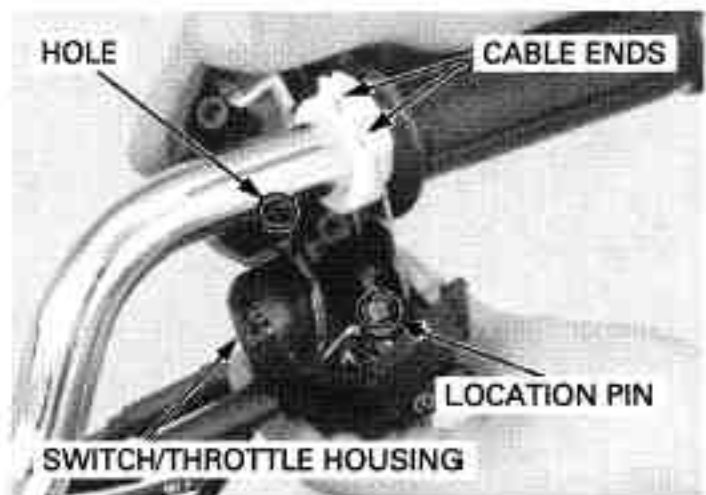

Place the handlebar on the lower holders aligning the punch mark on the handlebar with the top surface of the lower holders.
Install the handlebar holder with its punch mark facing forward.
Install the holder bolts.
Tighten the front bolts first, then tighten the rear bolts to the specified torque.

TORQUE: 26 N·m (2.7 kgf·m, 20 lbf·ft)

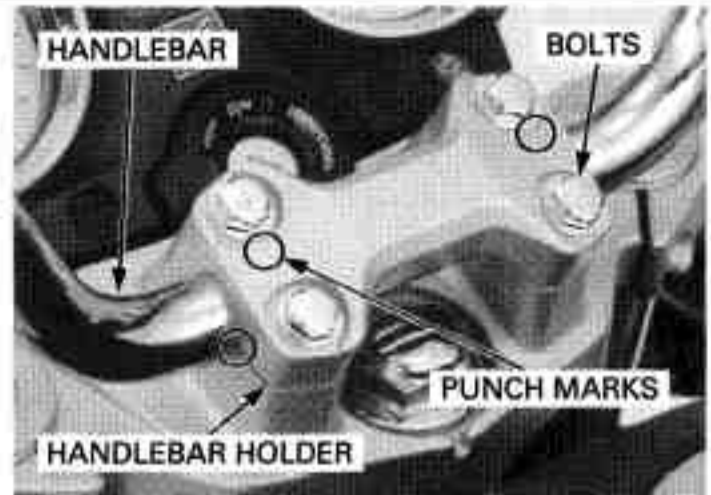

Tighten the forward screw first, then the rear screw.

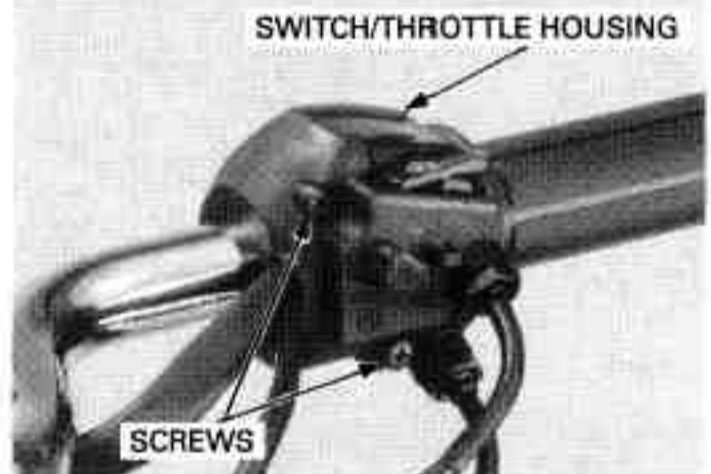

Install the right handlebar weight, aligning its tab with the groove in handlebar.



Install and tighten the screw securely.

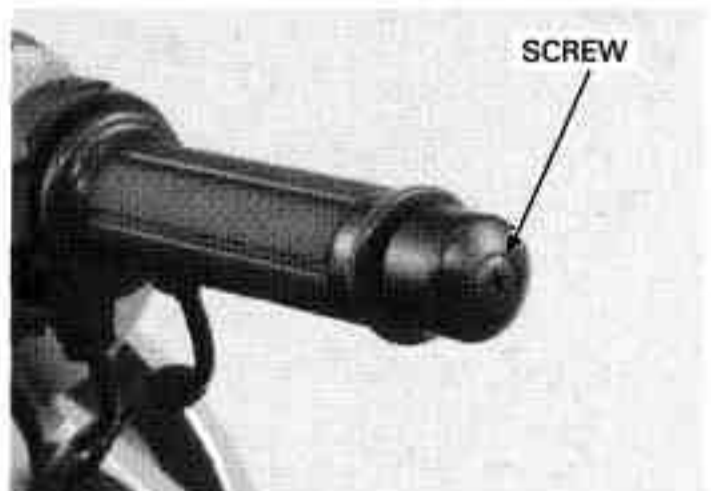

FRONT WHEEL/SUSPENSION/STEERING

HANDLEBAR WEIGHT REPLACEMENT

Remove the grip from the handlebar.
Straighten the weight retainer tab with a the screwdriver or punch.

Apply lubricant spray through the tab locking hole to the rubber for easy removal.

Temporarily install the grip end and screw, then remove the handlebar weight by turning the grip end.

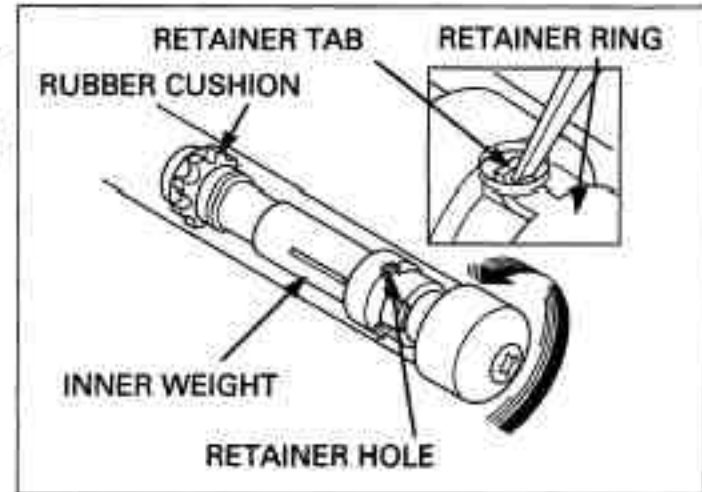

Remove the grip end from the handlebar weight.
Discard the retainer.

Install the new retainer onto the handlebar weight.
Install the grip end onto the handlebar weight aligning its boss with the slot in the handlebar weight.
Install a new mounting screw.

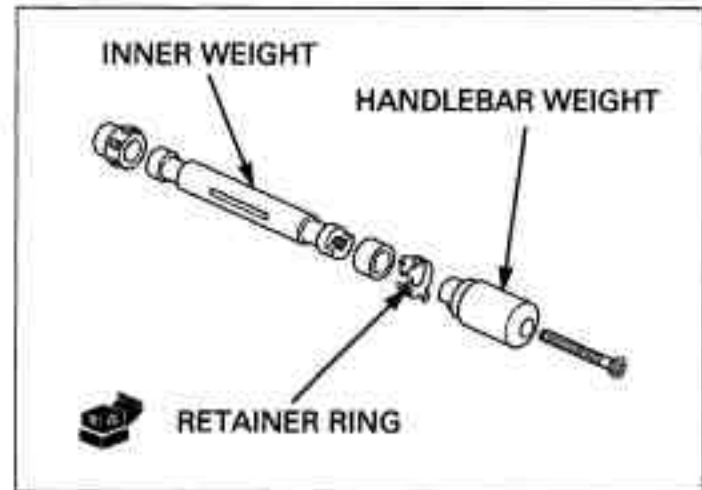

Insert the handlebar weight assembly into the handlebar.
Turn the handlebar weight and hook the retainer tab with the hole in the handlebar.

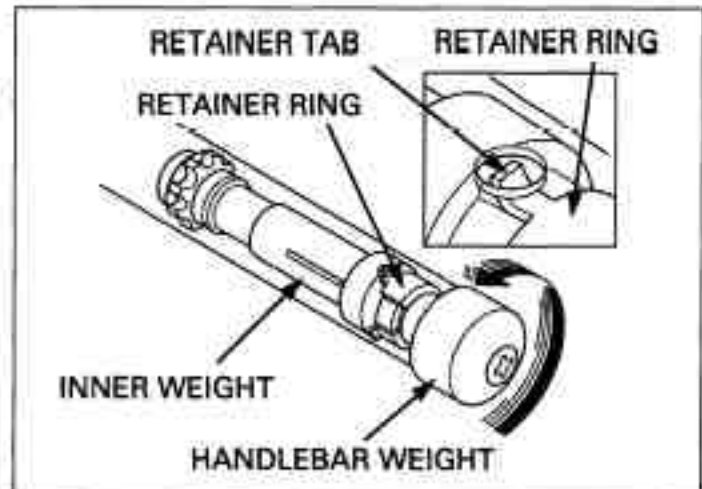

Install the choke lever onto the left side of the handlebar.

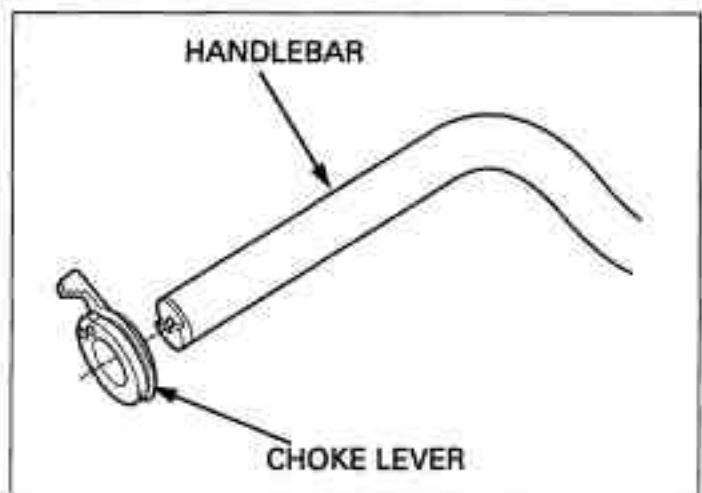

Apply Honda Bond A or equivalent adhesive to the inside of the grip and to the clean surfaces of the left handlebar and throttle grip.

Wait 3 – 5 minutes and install the grip.

Allow the adhesive to dry for an hour before using.

Rotate the grip for even application of the adhesive.

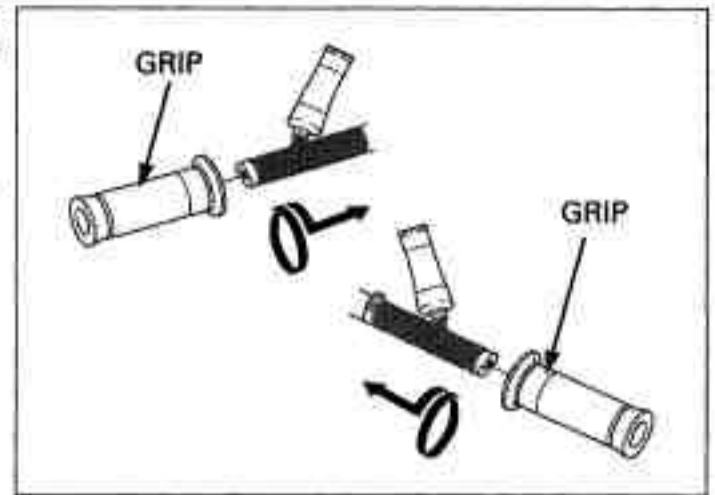

Install the right handlebar weight, aligning its tab with the groove in handlebar.

Install and tighten the screw securely.

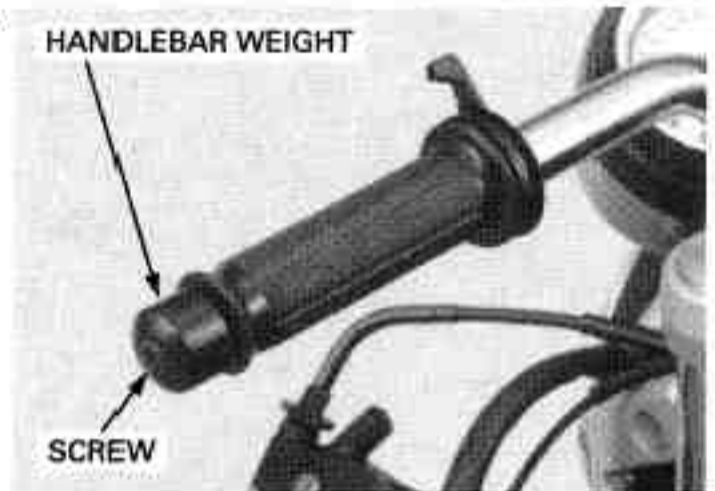

Connect the choke cable to the choke lever.

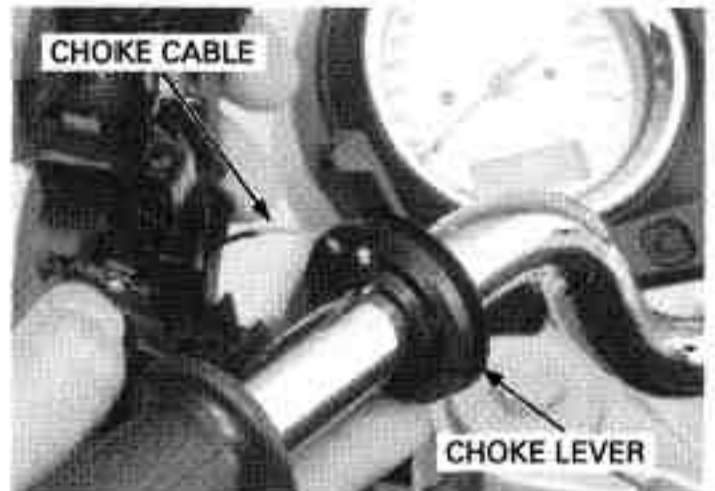

Install the left handlebar switch housing aligning its locating pin with the hole in the handlebar.

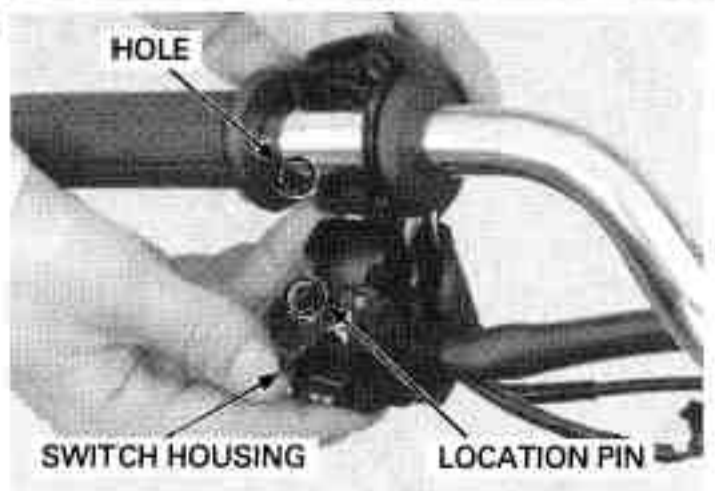

FRONT WHEEL/SUSPENSION/STEERING

Tighten the forward screw first, then the rear screw.

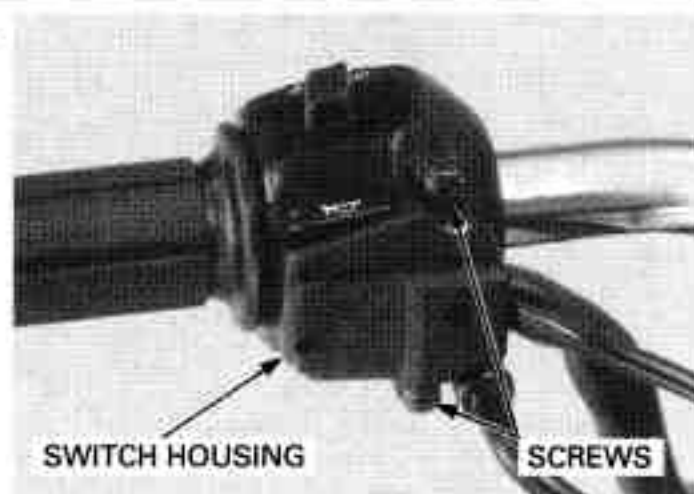

Install the clutch lever bracket assembly by aligning the end of the bracket with the punch mark on the handlebar.
Install the clutch lever bracket holder with the "UP" mark facing up.
Tighten the upper bolt first, then the lower bolt.
Connect the clutch switch wire connectors.

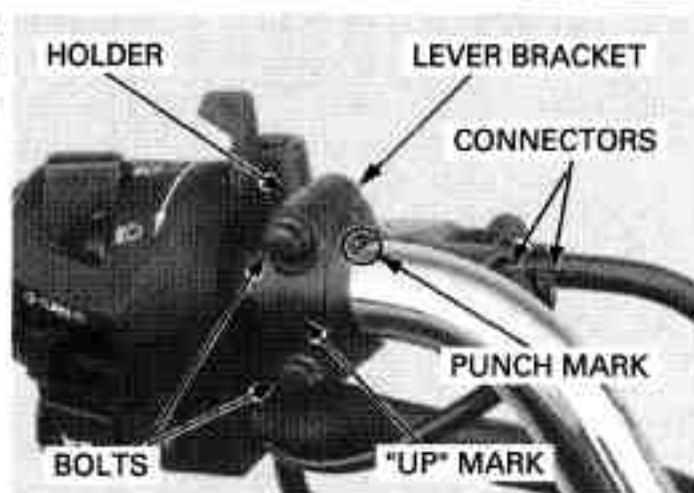

Install the master cylinder by aligning the end of the master cylinder with the punch mark on the handlebar.
Install the master cylinder holder with the "UP" mark facing up.
Tighten the upper bolt first, the lower bolt.
TORQUE: 12 N·m (1.2 kgf·m, 9 lbf·ft)
Connect the brake switch wire connectors.

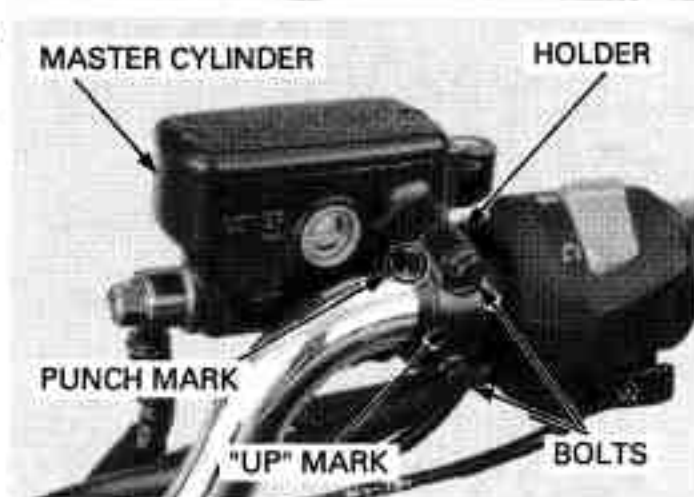

Install the rearview mirrors.
Tighten the mounting nuts to the specified torque.
TORQUE: 3.4 N·m (0.35 kgf·m, 2.5 lbf·ft)



FRONT WHEEL

REMOVAL

Loosen the right axle holder bolt and axle bolt.

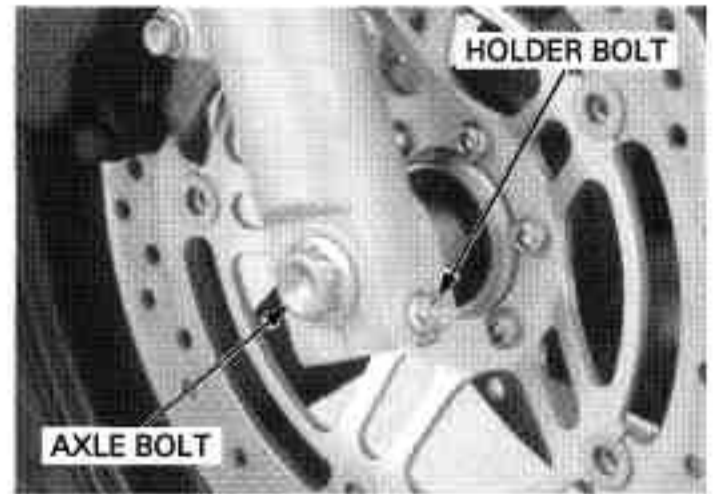

Support the motorcycle securely using a safety stand or a hoist.

Remove the mounting bolts and left brake caliper.

Do not operate the brake lever after the brake caliper is removed.

Support the brake caliper with a piece of wire so that it does not hang from the brake hose. Do not twist the brake hose.

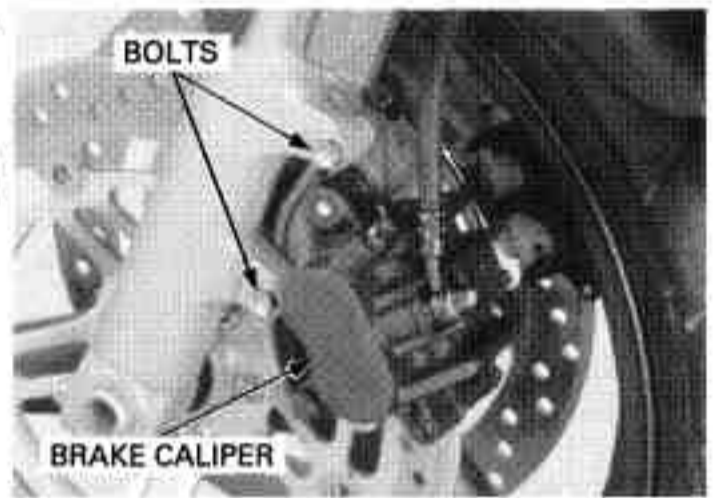

Remove the axle bolt.

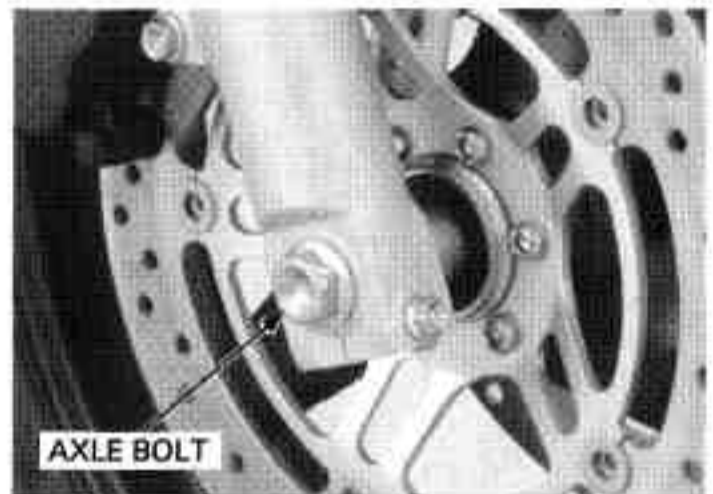

Loosen the left axle holder bolt.
Remove the axle and the front wheel.

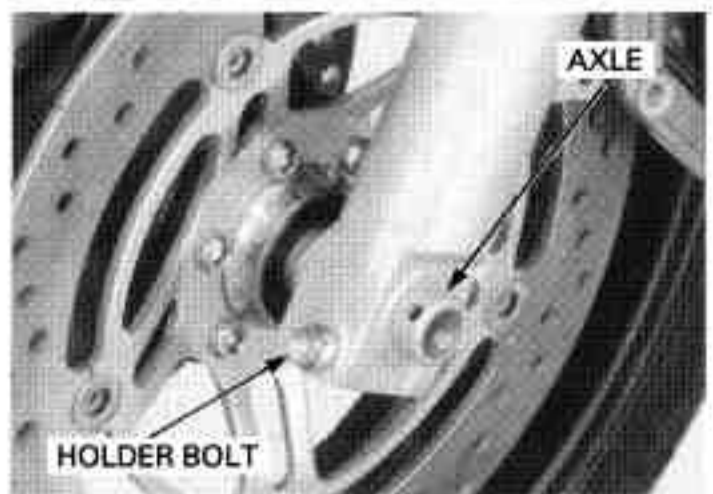

FRONT WHEEL/SUSPENSION/STEERING

Remove the side collars.

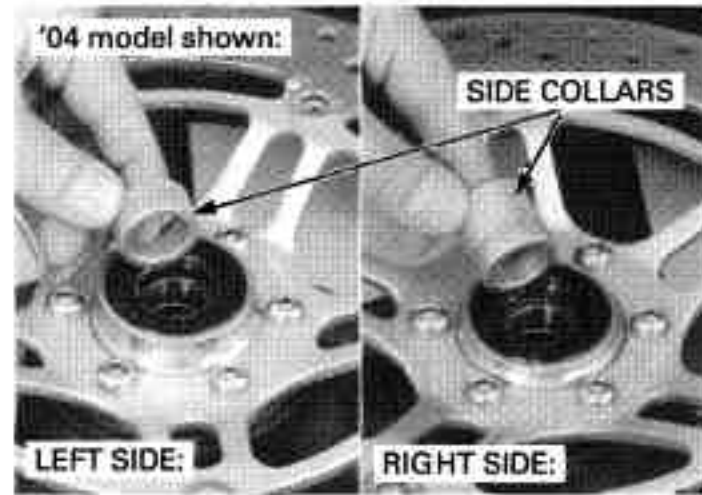

INSPECTION

Axle

Set the axle in V-block and measure the runout. Actual runout is 1/2 the total indicator reading.

SERVICE LIMIT: 0.2 mm (0.01 in)

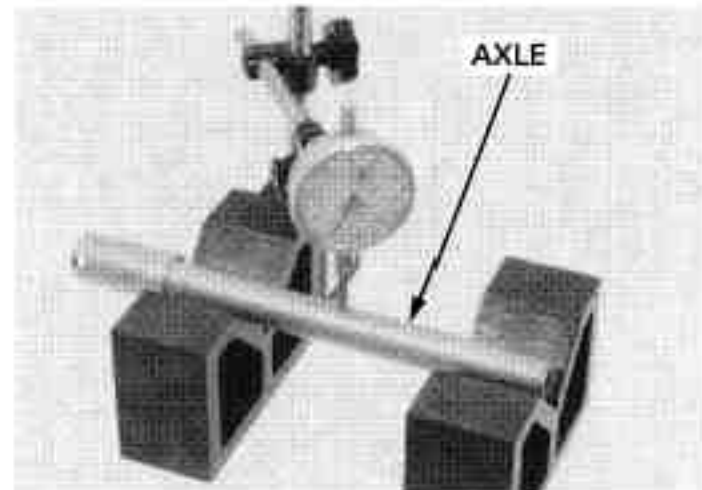

Wheel bearing

Turn the inner race of each bearing with your finger. The bearings should turn smoothly and quietly. Also check that the bearing outer race fits tightly in the hub.

Replace the bearings in pairs.

Remove and discard the bearings if they do not turn smoothly, quietly, or if they fit loosely in the hub.

Replace a new bearings, if necessary (page 14-17).

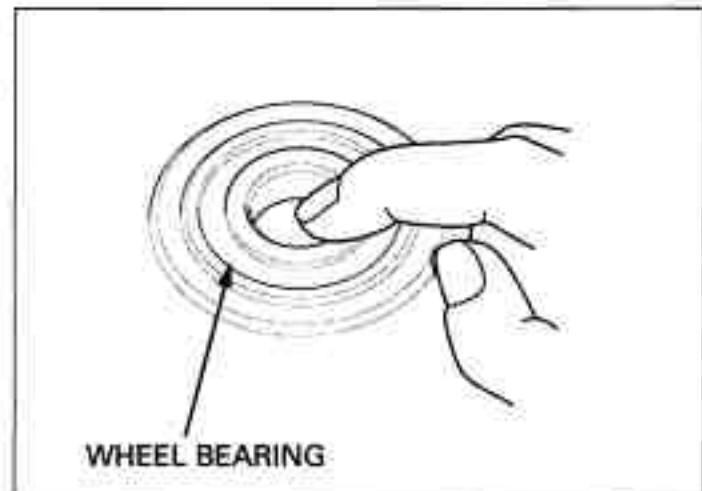

Wheel rim runout

Check the rim runout by placing the wheel in a turning stand.

Spin the wheel by hand, and read the runout using a dial indicator.

Actual runout is 1/2 the total indicator reading.

SERVICE LIMITS:

Radial: 2.0 mm (0.08 in)

Axial: 2.0 mm (0.08 in)

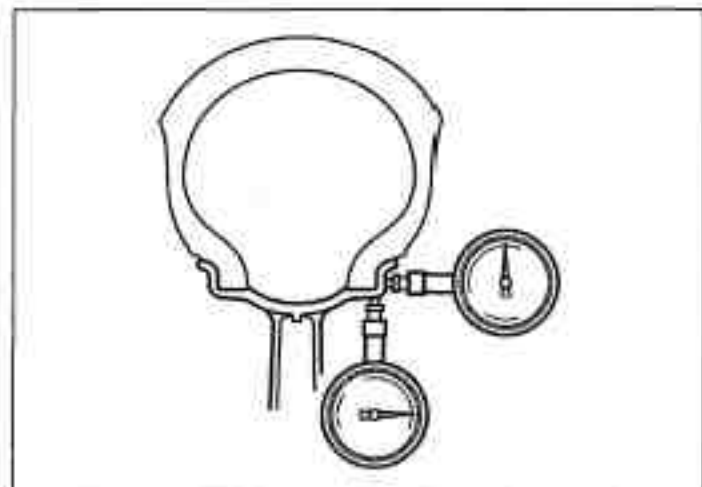

For optimum balance, the tire balance mark (a paint dot on the side wall) must be located next to the valve stem. Remount the tire if necessary.

Wheel balance

Always check balance when the tire has been removed from the rim.

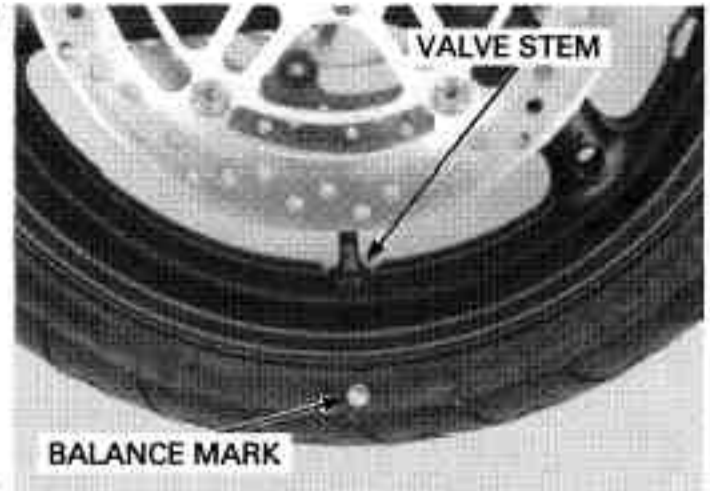

Note the rotating direction marks on the wheel and tire.



Remove the dust seals from the wheel. Mount the wheel, tire and brake discs assembly in an inspection stand. Spin the wheel, allow it to stop, and mark the lowest (heaviest) point of the wheel with a chalk. Do this two or three times to verify the heaviest area. If the wheel is balanced, it will not stop consistently in the same position.

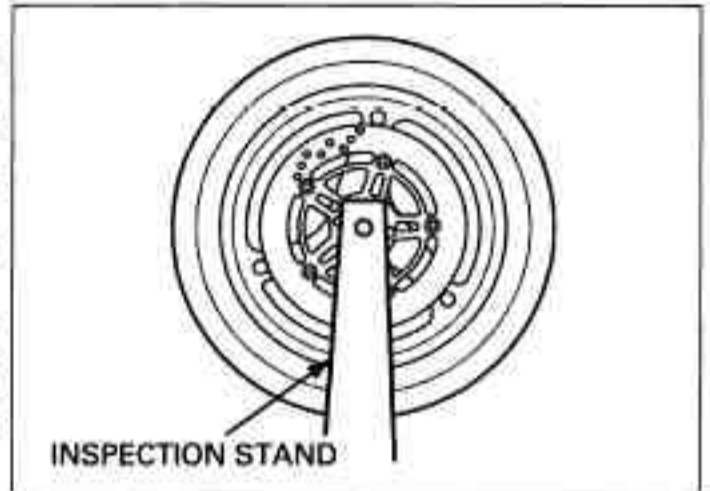

To balance the wheel, install wheel weights on the highest side of the rim, the side opposite the chalk marks. Add just enough weight so the wheel will no longer stop in the same position when it is spun. Do not add more than 60 grams to the wheel.

NOTE:

After '04 model is equipped with a new shape balance weight made of zinc spelter. This balance weight is incompatible with the conventional one in case of installation to the wheel.

DISASSEMBLY

Remove the bolts and brake discs. Remove the dust seals.

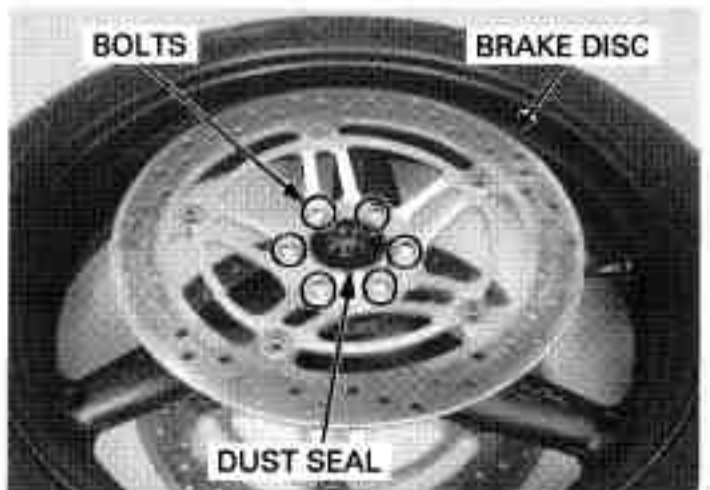

FRONT WHEEL/SUSPENSION/STEERING

Install the bearing remover head into the bearing. From the opposite side, install the bearing remover shaft and drive the bearing out of the wheel hub. Remove the distance collar and drive out the other bearing.

TOOLS:

Bearing remover head, 20 mm 07746-0050600

Bearing remover shaft 07GGD-0010100 or 07746-0050100



ASSEMBLY

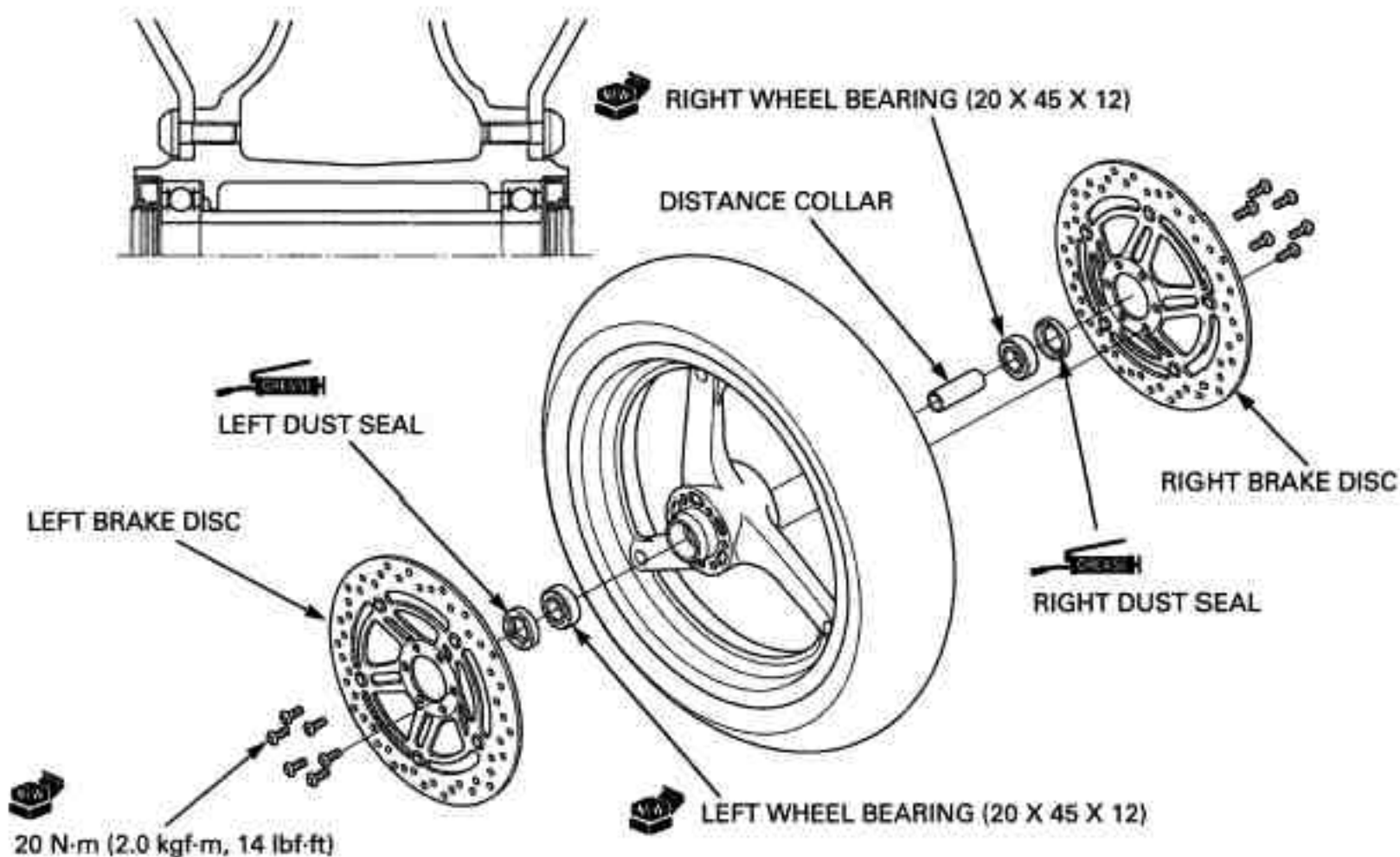

Never install the old bearings. Once the bearings has been removed, the bearing must be replaced with new ones.

Drive in a new right bearing squarely. Install the distance collar, then drive in the left bearing using the special tool.

TOOLS:

Driver

Attachment, 42 X 47 mm

Pilot, 20 mm

07749-0010000

07746-0010300

07746-0040500

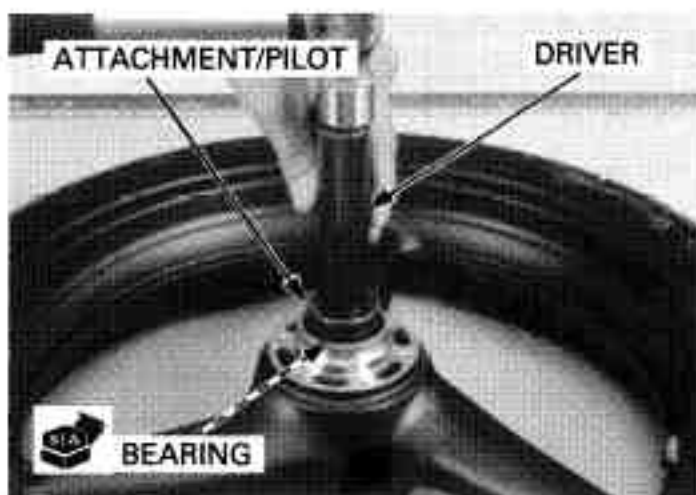

Do not get grease on the brake discs or stopping power will be reduced.

Install the brake discs on the wheel hub. Install and tighten new mounting bolts to the specified torque.

TORQUE: 20 N·m (2.0 kgf·m, 14 lbf·ft)

Apply grease to the dust seal lips, then install them into the wheel hub.

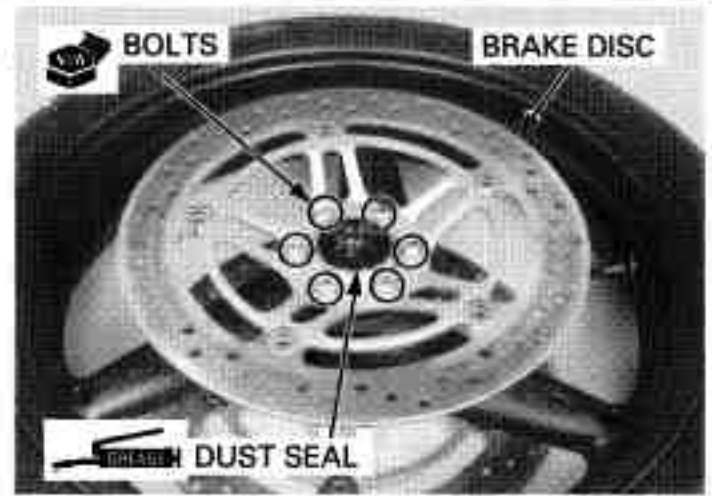

INSTALLATION

Install the side collars.

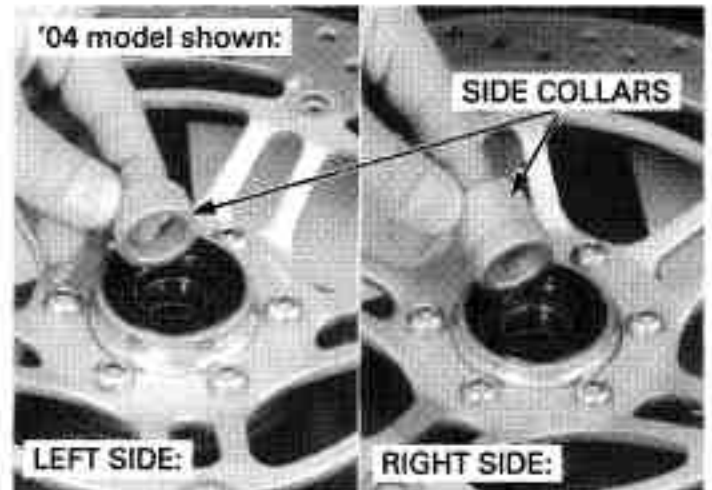

Install the front wheel between the fork legs.

Apply thin layer of grease to the front axle surface. Install the front axle from the left side.

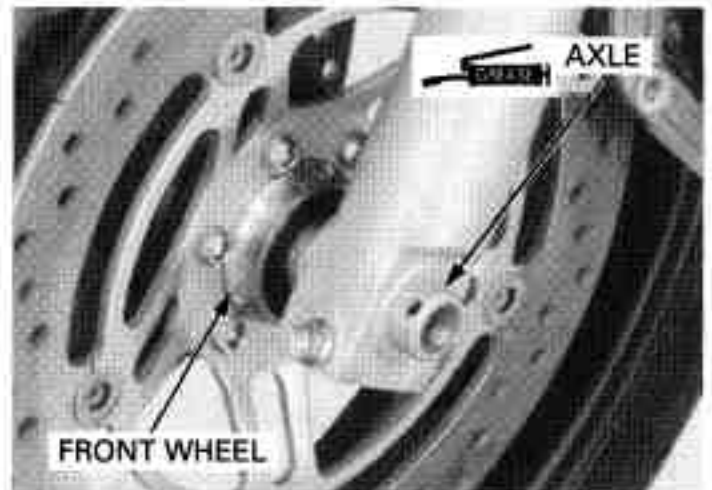

Hold the axle and tighten the axle bolt to the specified torque.

TORQUE: 59 N·m (6.0 kgf·m, 43 lbf·ft)

Tighten the right axle holder bolt to the specified torque.

TORQUE: 22 N·m (2.2 kgf·m, 16 lbf·ft)

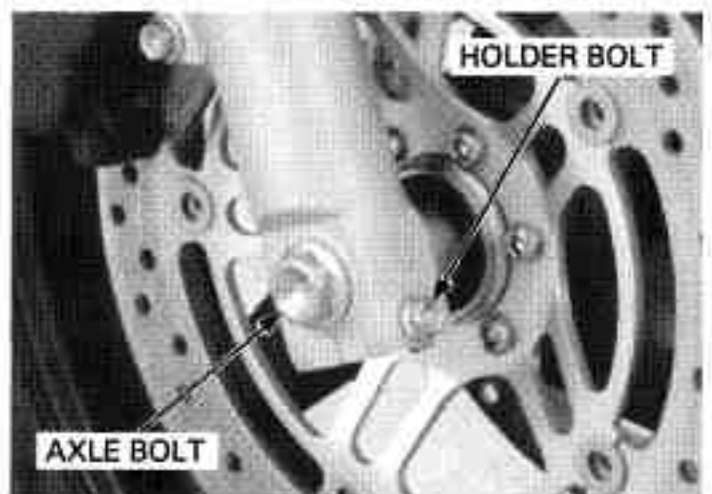

FRONT WHEEL/SUSPENSION/STEERING

Install the left brake caliper and tighten the new mounting bolts to the specified torque.

TORQUE: 30 N-m (3.1 kgf-m, 22 lbf-ft)

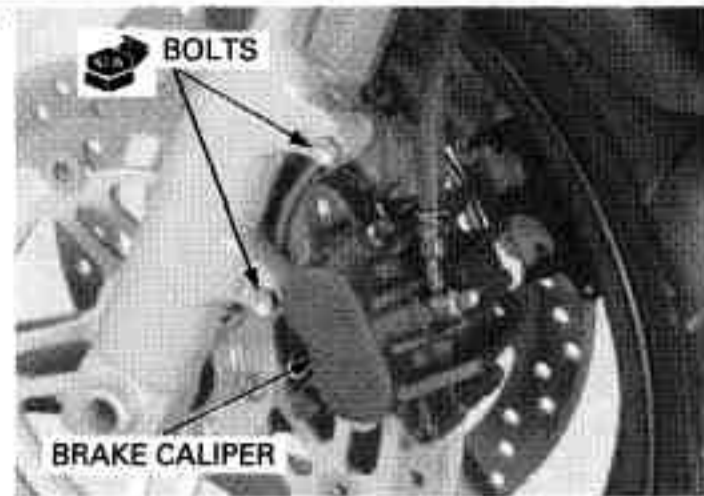

With the front brake applied, pump the fork up and down several times to seat the axle and check brake operation by applying the brake lever.



Tighten the left axle holder bolt to the specified torque.

TORQUE: 22 N-m (2.2 kgf-m, 16 lbf-ft)



Check the clearance between the brake disc and caliper bracket on each side after installation. The clearance should be at least 0.7 mm (0.03 in).

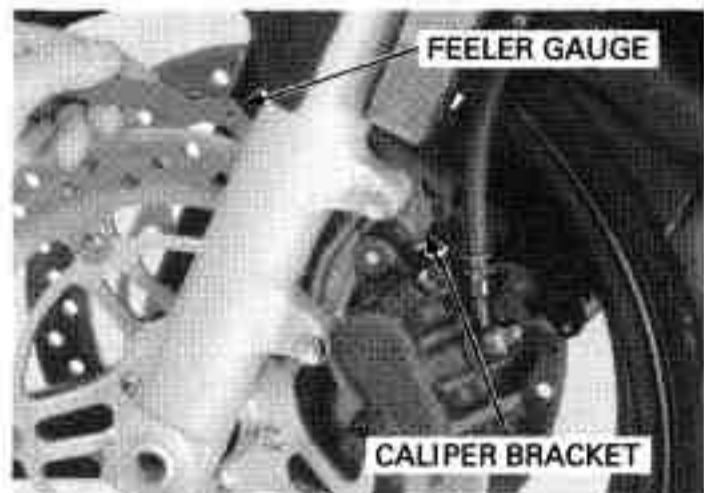

FORK

REMOVAL

Remove the front wheel (page 14-15).

Right side only: Remove the mounting bolts and right brake caliper.

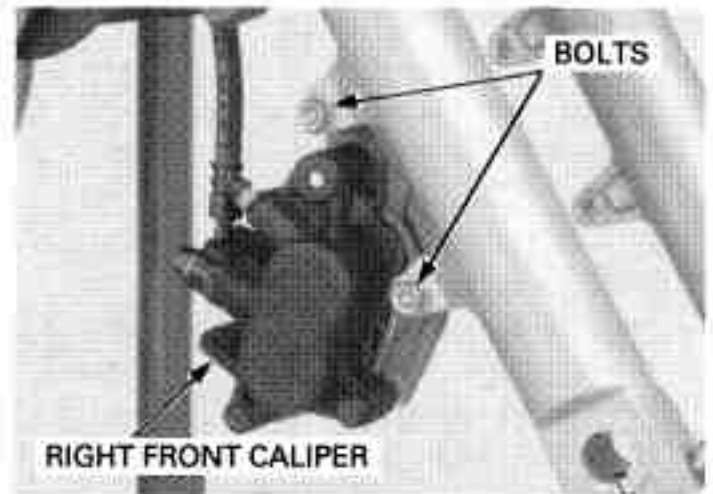

Remove the bolts, front reflectors, socket bolts and front fender (page 3-7).

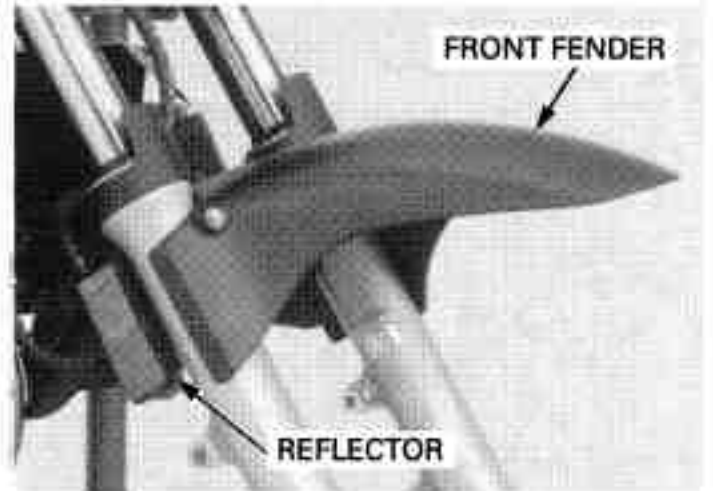

Loosen the fork top bridge pinch bolt.

When the fork leg will be disassembled, loosen the fork cap, but do not remove it yet.

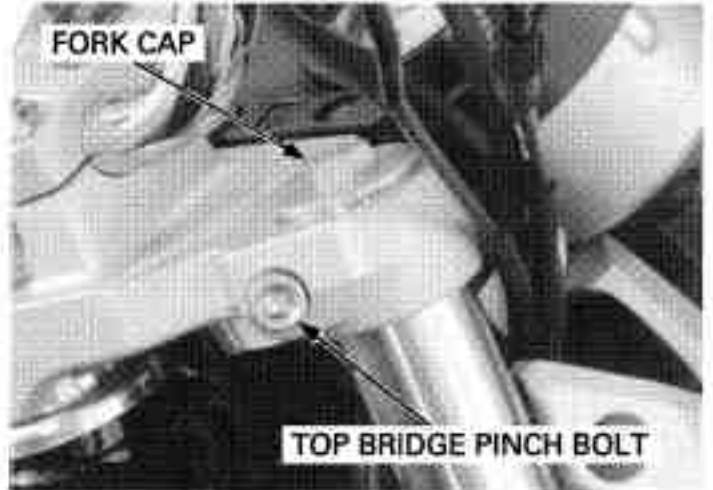

Loosen the fork bottom bridge pinch bolt and remove the fork tube from the fork top bridge and steering stem.

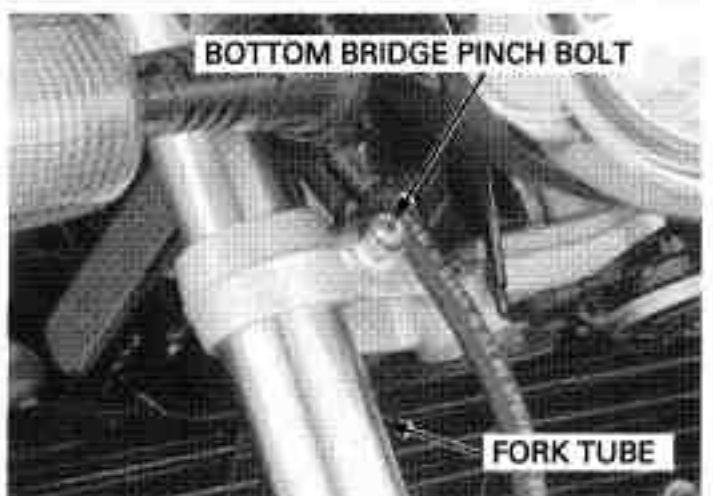

FRONT WHEEL/SUSPENSION/STEERING

DISASSEMBLY ('04 model)

The fork spring is under pressure. Use care when removing the fork cap.

Remove the fork cap from the fork tube.

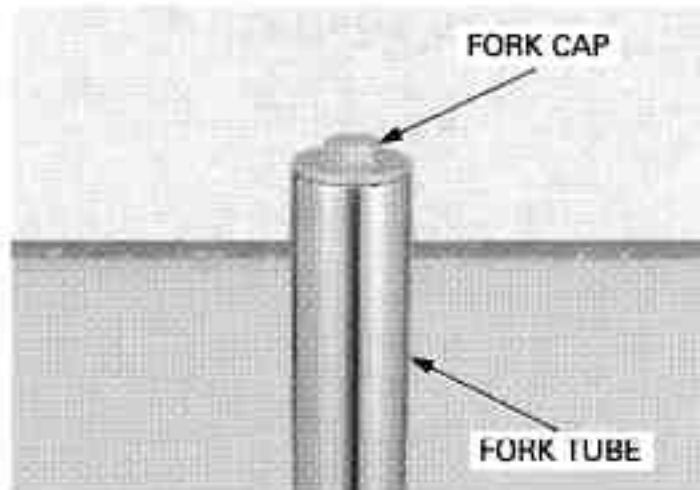

Remove the spacer and distance collar from the fork tube.

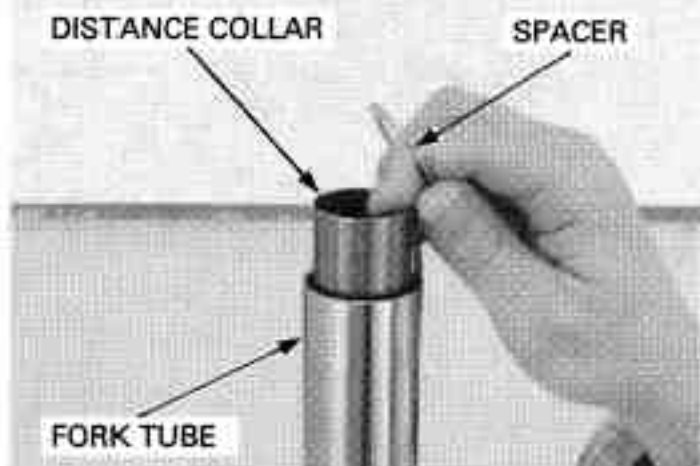

Remove the spring seat and fork spring from the fork tube.

Pour out the fork fluid by pumping the fork tube several times.

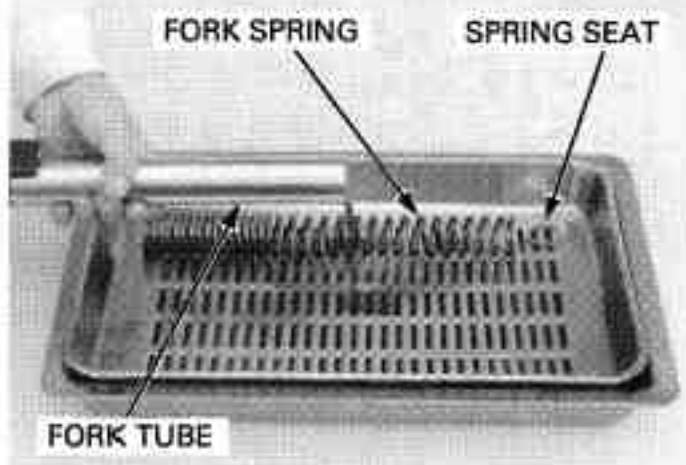

Remove the spring collar from the fork tube.

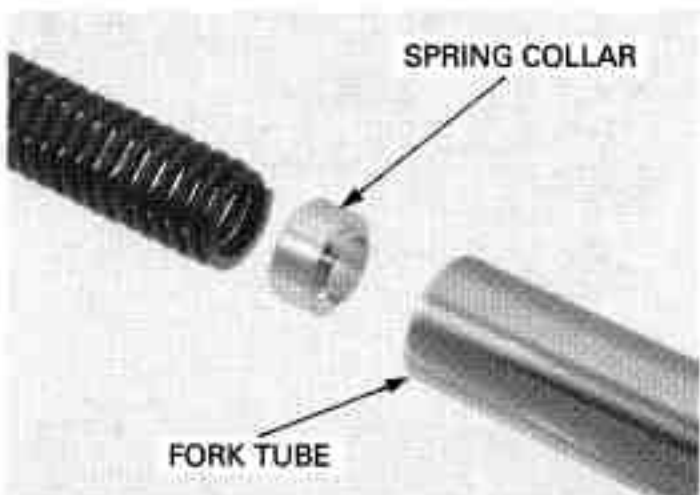

Remove the axle holder bolt from the fork slider.

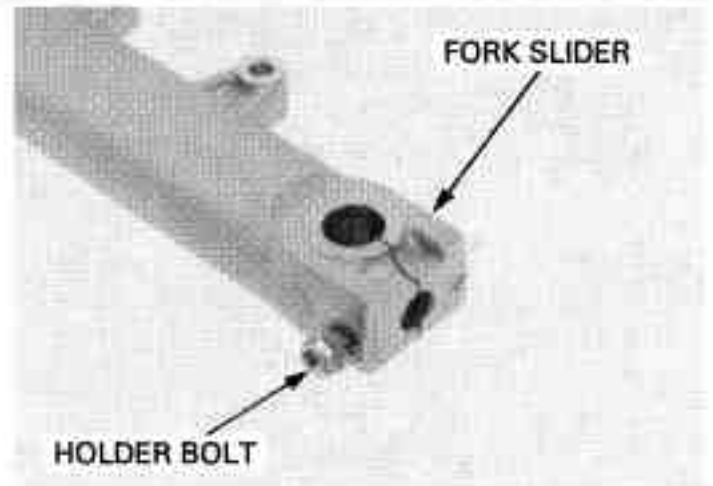

Hold the fork slider in a vice with soft jaws or a shop towel.

Remove the fork socket bolt and sealing washer.



If the fork piston turns together with the socket bolt, temporarily install the spring collar, fork spring, spring seat, distance collar, spacer and fork cap.

Do not remove the fork piston ring, unless it is necessary to replace with a new one.

Remove the fork piston and rebound spring from the fork tube.

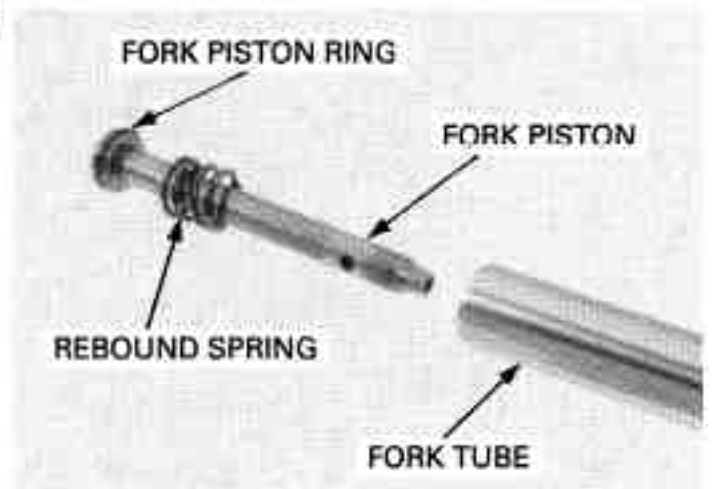

Be careful not to scratch the fork tube or damage the dust seal.

Remove the fork protector by prying it carefully using a screwdriver.

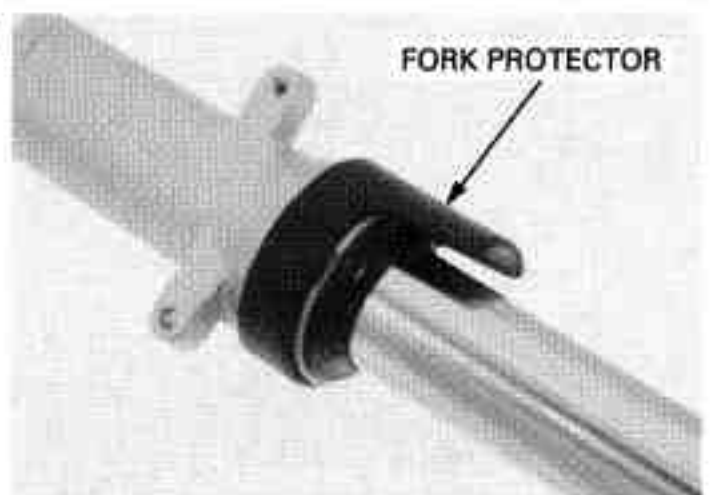

FRONT WHEEL/SUSPENSION/STEERING

Remove the dust seal.

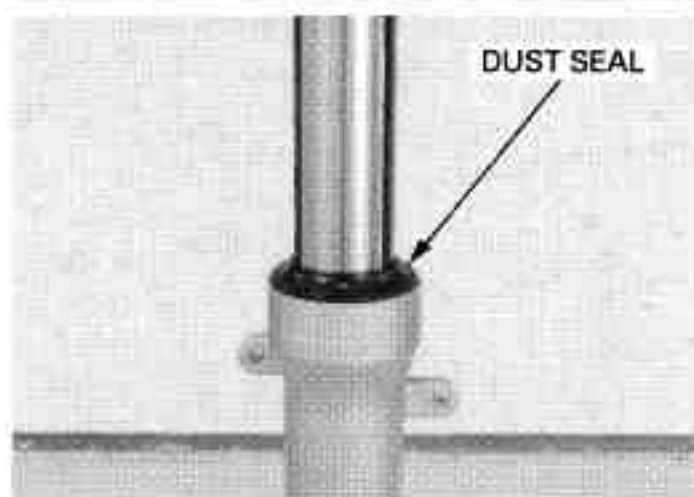

*Do not scratch the
fork tube sliding
surface.*

Remove the stopper ring.

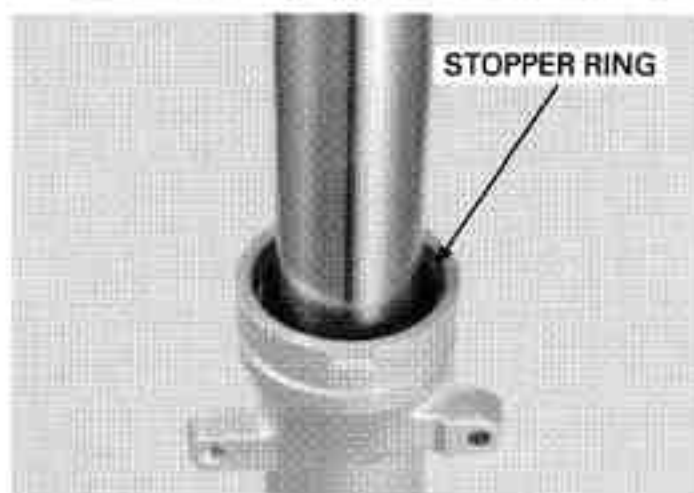

Pull the fork tube out until you feel resistance from the slider bushing. Then move it in and out, tapping the bushing lightly until the fork tube separates from the fork slider. The slider bushing will be forced out by the fork tube bushing.

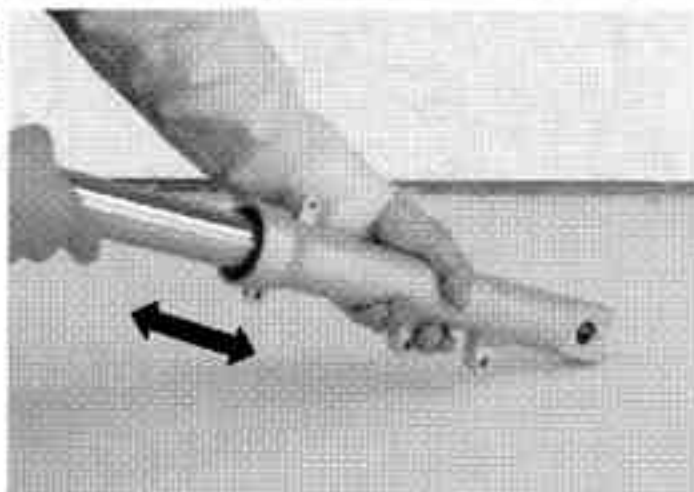

Remove the oil lock piece from the fork slider.

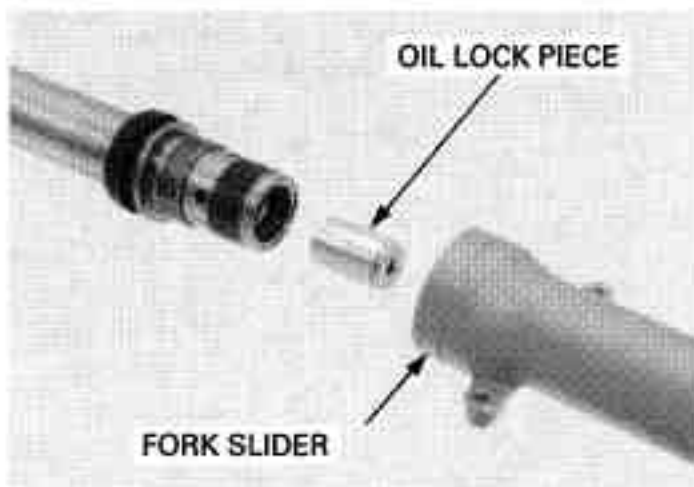

Remove the oil seal, back-up ring and slider bushing from the fork tube.

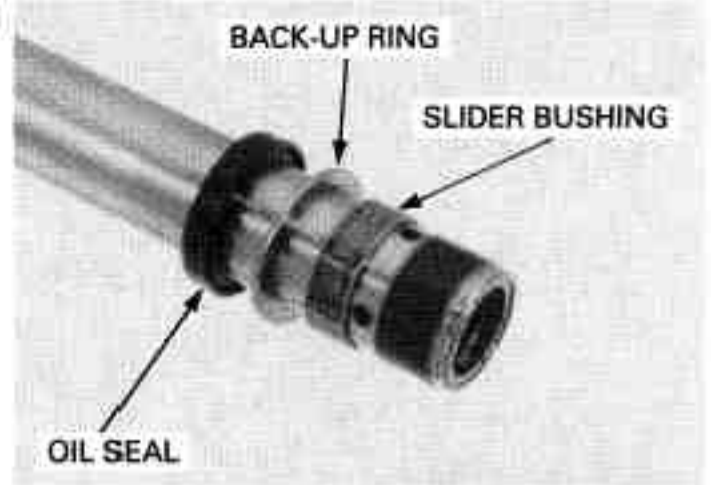

Do not remove the fork tube bushing unless it necessary to replace it with a new one.

Carefully remove the fork tube bushing by prying the slit with a screwdriver until the bushing can be pulled off by hand.



DISASSEMBLY (After '04 model)

Remove the front fork bolt from the fork slider.

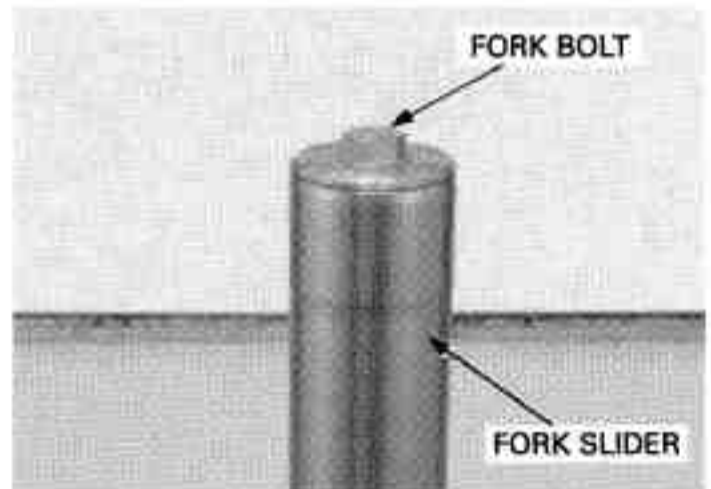

Be careful not to damage the spring collar holes.

Set the spring collar holder to the spring collar holes.

TOOLS:
Spring collar holder 070MF-MBZC110

Compress the spring collar with the spring collar holder.

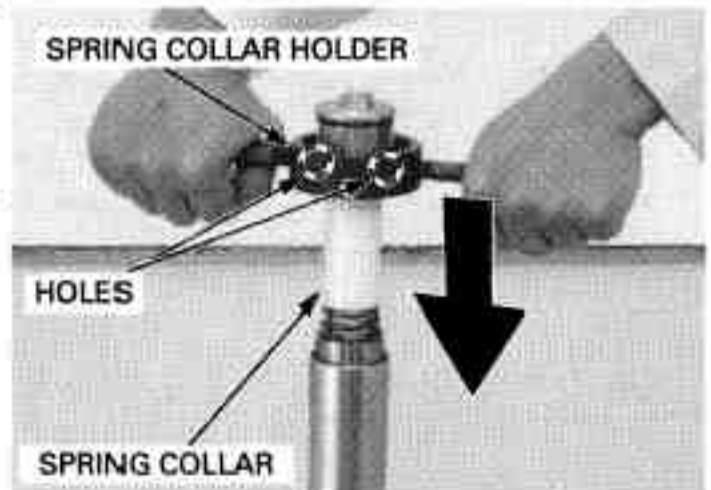

FRONT WHEEL/SUSPENSION/STEERING

Insert the stopper plate between the nut and the spring collar.

TOOLS:

Stopper plate 070MF-MBZC130

Loosen the lock nut with holding the front fork bolt.

Remove the front fork bolt.

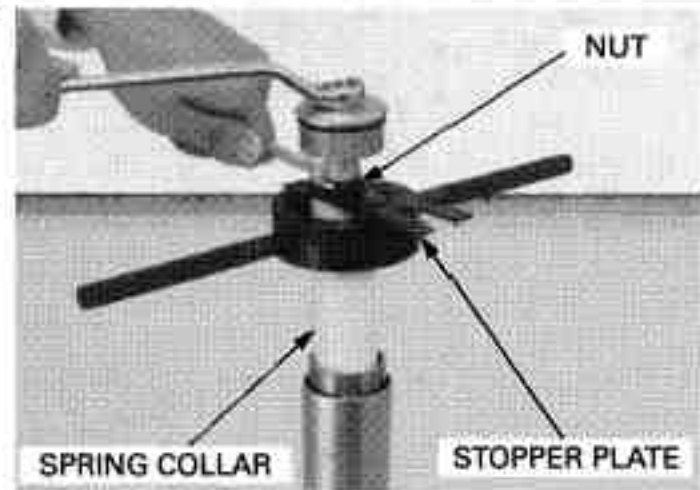

Remove the spring collar and the fork spring from the fork slider.

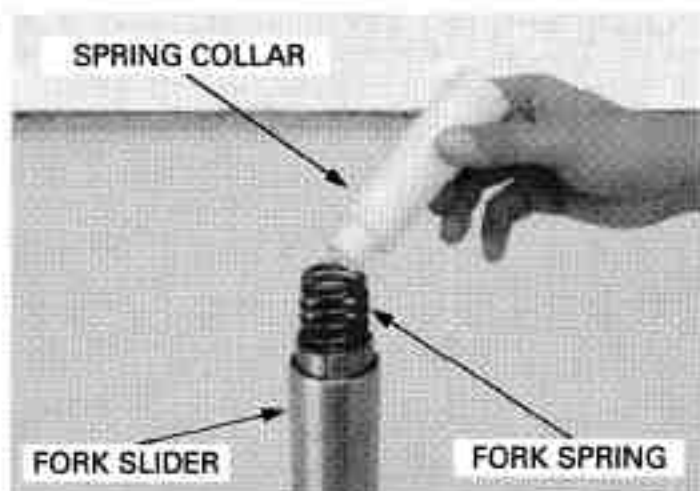

Pour out the fork fluid by pumping the fork slider several times.

And also pour out the fork fluid from the fork damper by pumping the fork damper rod several times.

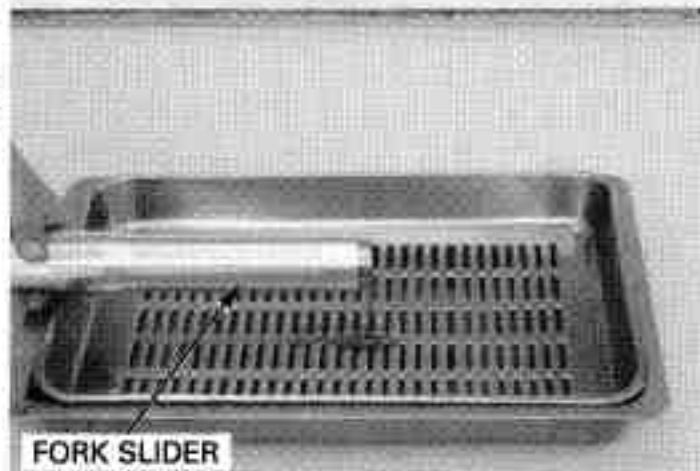

Hold the axle holder in a vice with soft jaws or a shop towel.

Hold the fork damper with the fork damper holder attachment, then remove the fork socket bolt and sealing washer.

TOOLS:

Fork damper holder attachment 07YMB-MCF0101



Remove the fork damper from the fork slider.

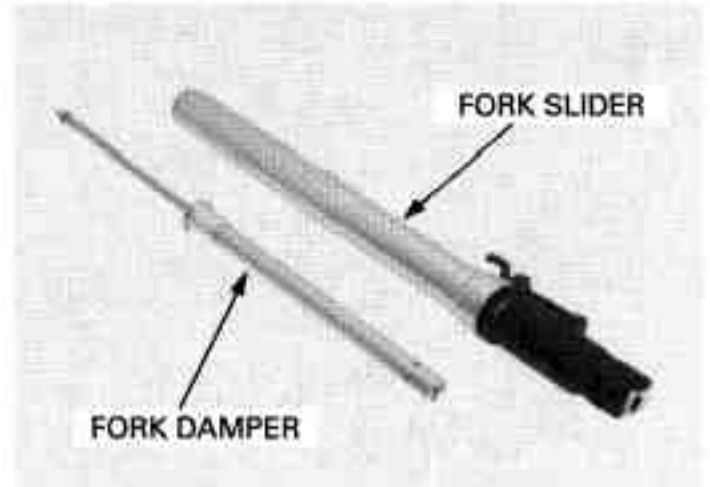

Remove the dust seal.

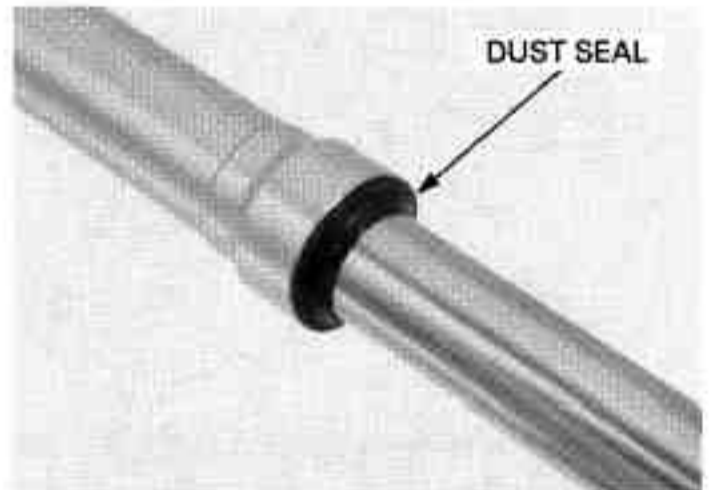

*Do not scratch the
fork tube sliding
surface.*

Remove the stopper ring.

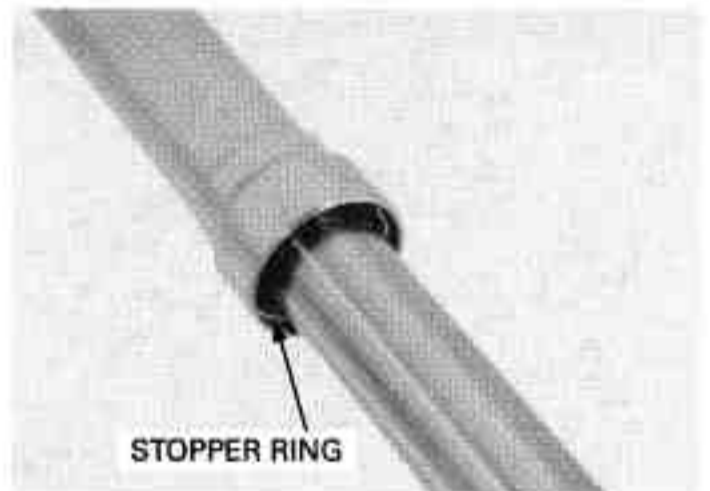

Pull the fork tube out until you feel resistance from the slider bushing. Then move it in and out, tapping the bushing lightly until the fork tube separates from the fork slider. The slider bushing will be forced out by the fork tube bushing.

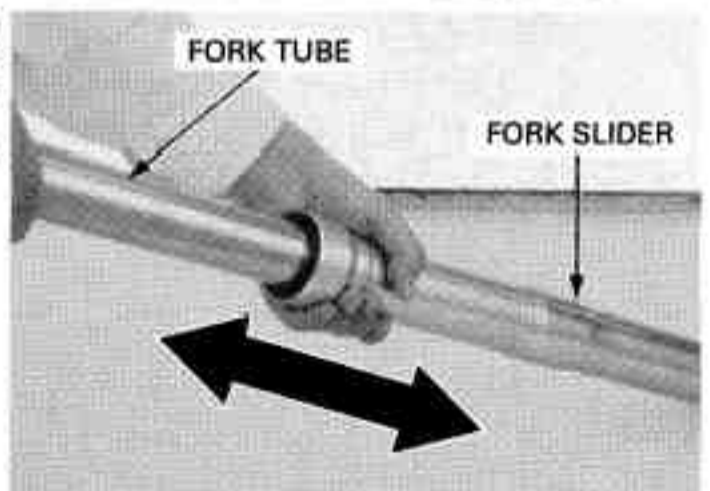

FRONT WHEEL/SUSPENSION/STEERING

Remove the oil seal, back-up ring and slider bushing from the fork tube.

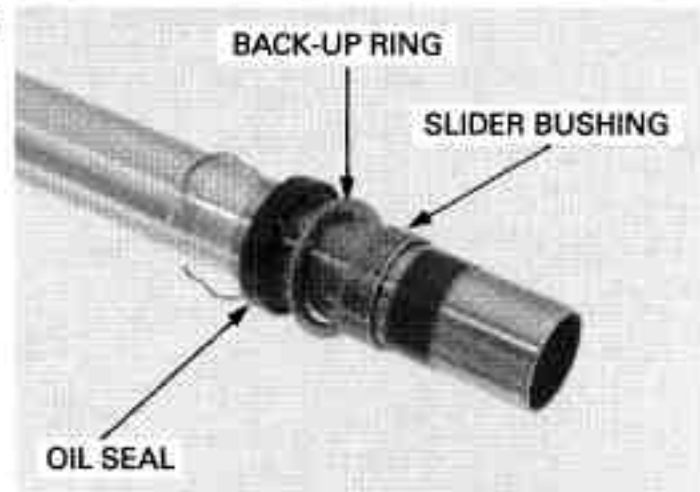

Do not remove the fork tube bushing unless it necessary to replace it with a new one.

Carefully remove the fork tube bushing by prying the slit with a screwdriver until the bushing can be pulled off by hand.



INSPECTION

Fork spring

Measure the fork spring free length.

SERVICE LIMIT:

'04 model: 331.5 mm (13.05 in)

After '04 model: 276.0 mm (10.9 in)

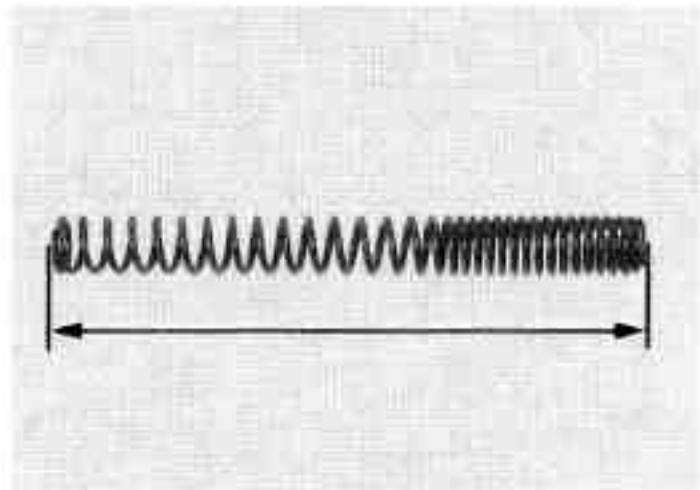

Fork tube/slider/piston ('04 model)

Check the fork tube and fork slider for score marks, scratches, or excessive or abnormal wear. Replace any components which are worn or damaged.

Replace the component if necessary.

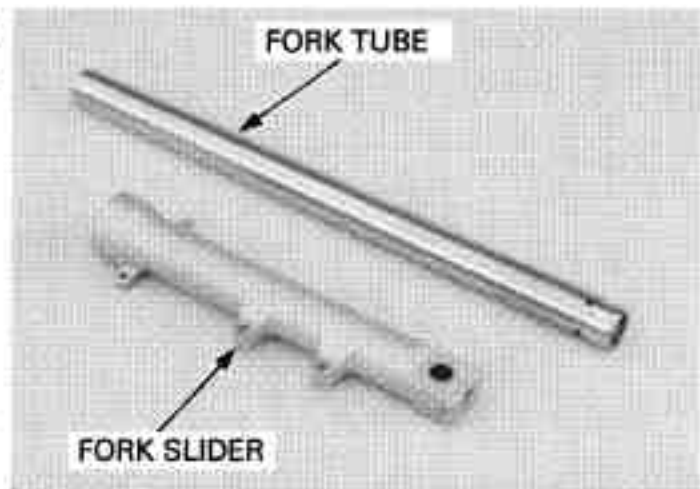

Place the fork tube in V-block and measure the runout.
Actual runout is 1/2 the total indicator reading.
SERVICE LIMIT: 0.20 mm (0.008 in)

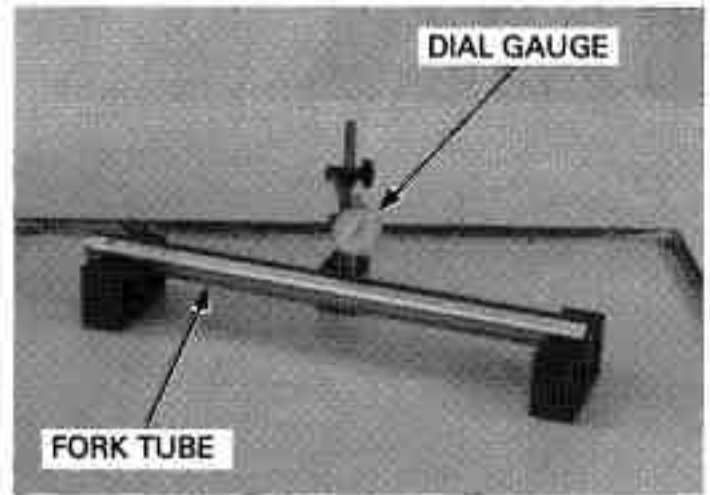

Check the fork piston ring for wear or damage.
Check the rebound spring for fatigue or damage.
Replace the component if necessary.

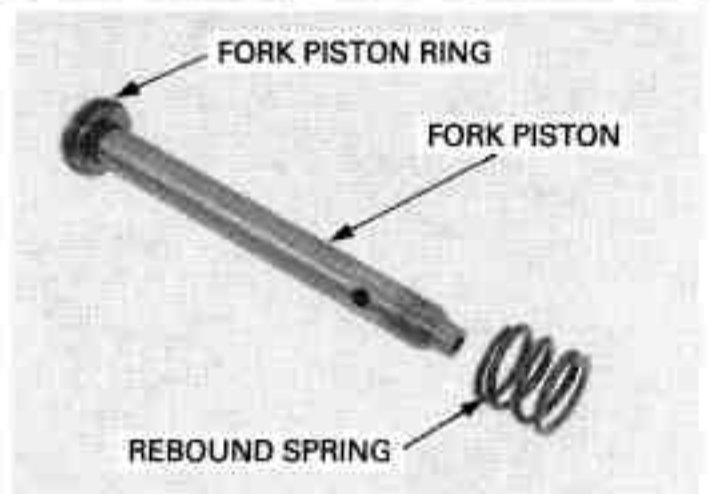

Fork tube/slider (After '04 model)

Check the fork tube and fork slider for score marks, scratches, or excessive or abnormal wear.
Replace any components which are worn or damaged.

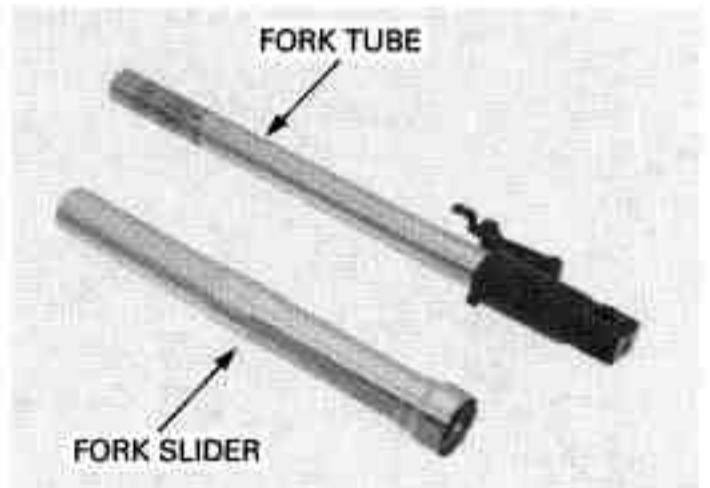

Check the oil lock valve for wear or damage.
Replace the fork damper, if any components is damaged.

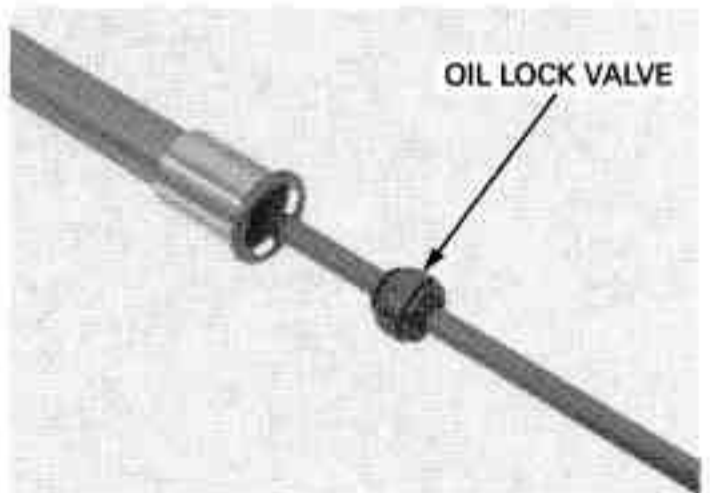

FRONT WHEEL/SUSPENSION/STEERING

Place the fork tube in V-block and measure the runout.

Actual runout is 1/2 of the total indicator reading.

SERVICE LIMIT: 0.20 mm (0.008 in)

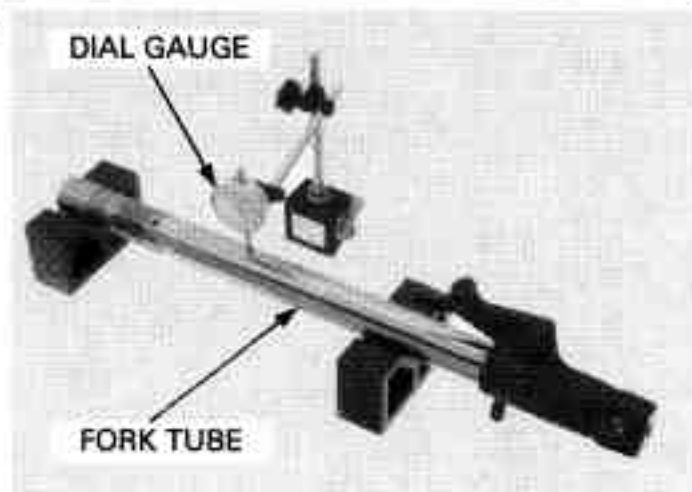

Fork tube bushing/slider bushing/back-up ring

Visually inspect the slider and fork tube bushings. Replace the bushings if there is excessive scoring or scratching, or if the teflon is worn so that the copper surface appears on more than 3/4 of the entire surface.

Check the back-up ring; replace it if there is any distortion at the points shown.

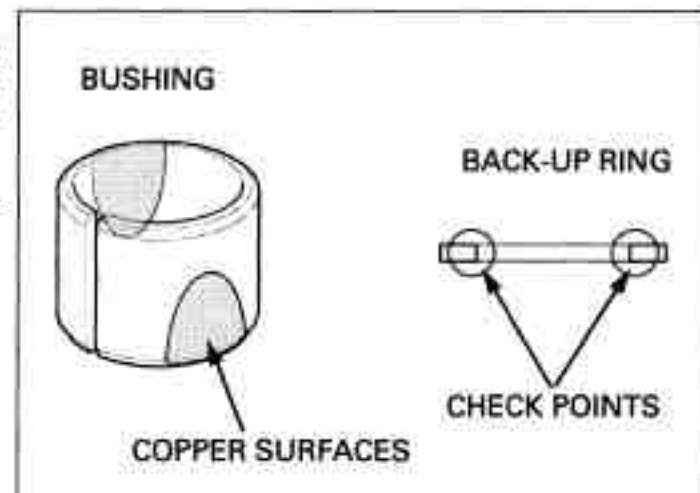

ASSEMBLY ('04 model)

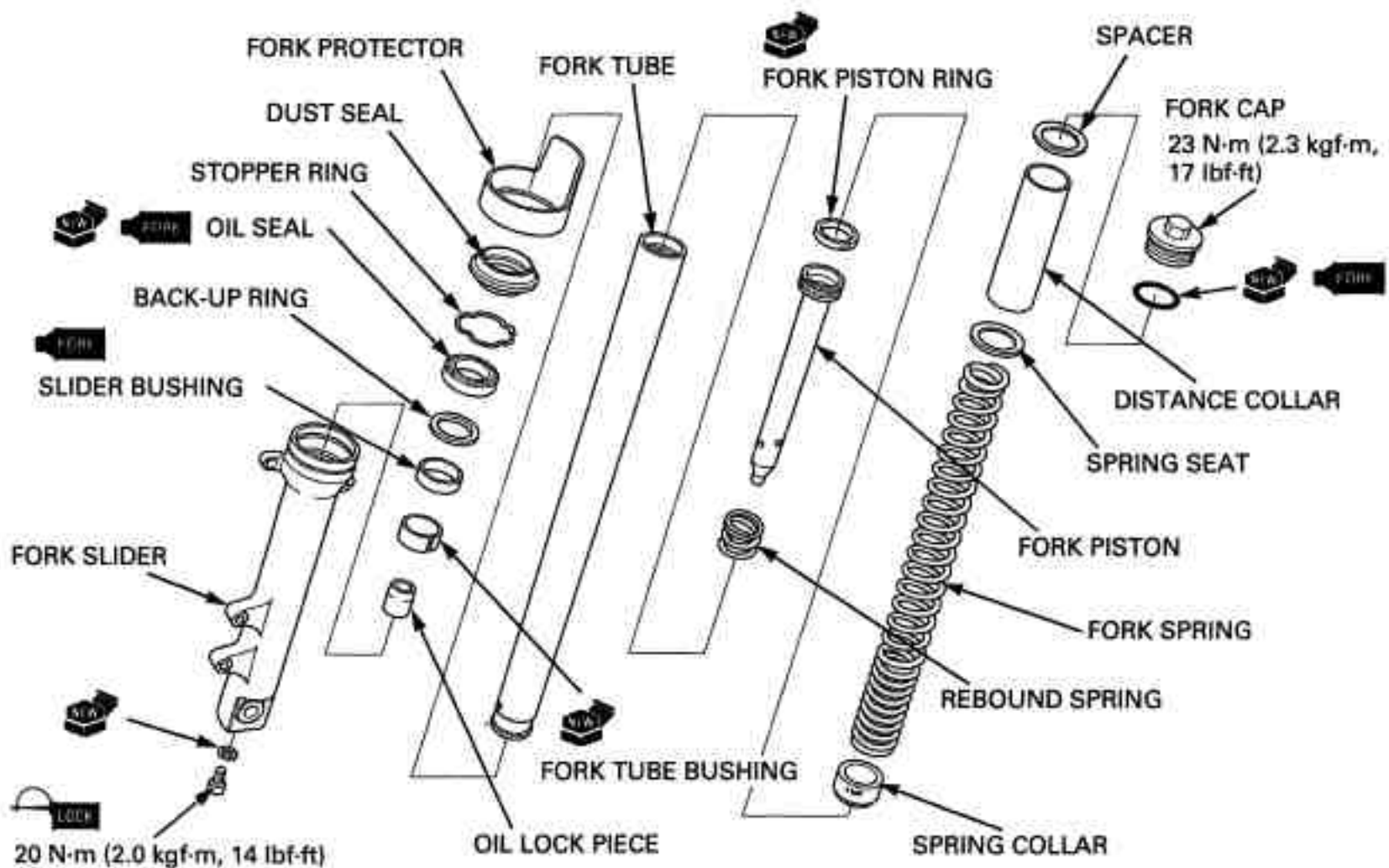

FRONT WHEEL/SUSPENSION/STEERING

Before assembly, wash all parts with a high flash or non-flammable solvent and wipe them dry.

Remove the burrs from the bushing mating surface, being careful not to peel off the coating.

Do not open the bushing slit more than necessary.

Install the new fork tube bushing being careful not to damage the coating of the bushing if it has been removed.



Apply fork fluid to the new oil seal lip.

Install the oil seal with its marked side facing up.

Install the slider bushing, back-up ring and new oil seal.



Install the rebound spring/fork piston to the fork tube.

Install the oil lock piece onto the fork piston end.

Apply fork fluid to the fork tube bushing and slider bushing, then install the fork tube into the fork slider.

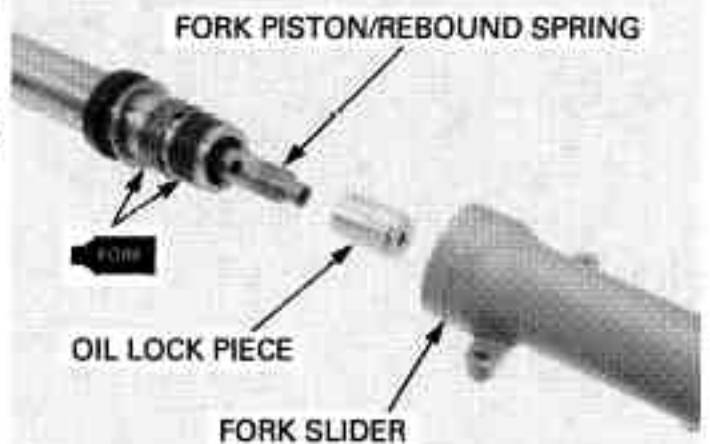

Drive the oil seal in using the special tools.

TOOLS:

Fork seal driver weight 07947-KA50100
Oil seal driver attachment 07947-KF00100

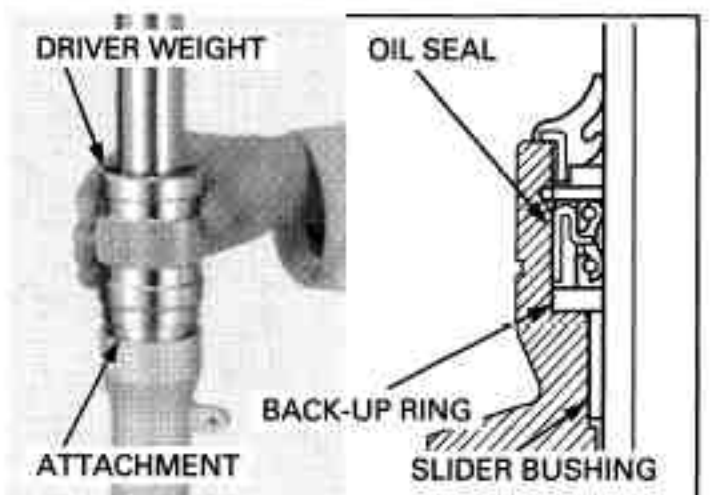

FRONT WHEEL/SUSPENSION/STEERING

Install the stopper ring into the fork slider groove securely.

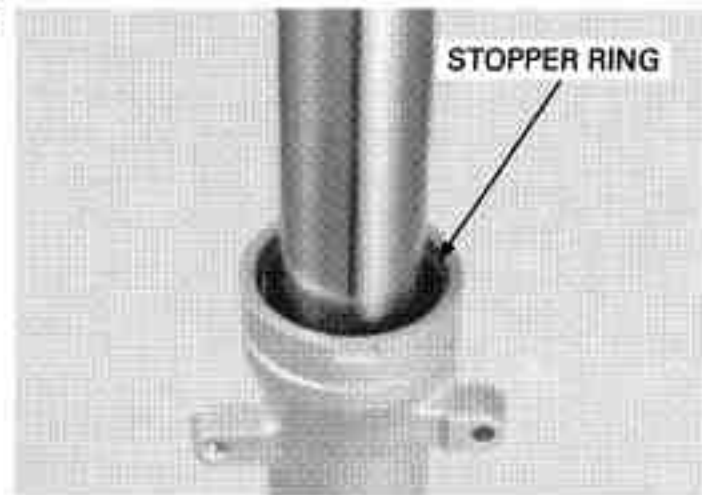

Install the dust seal.

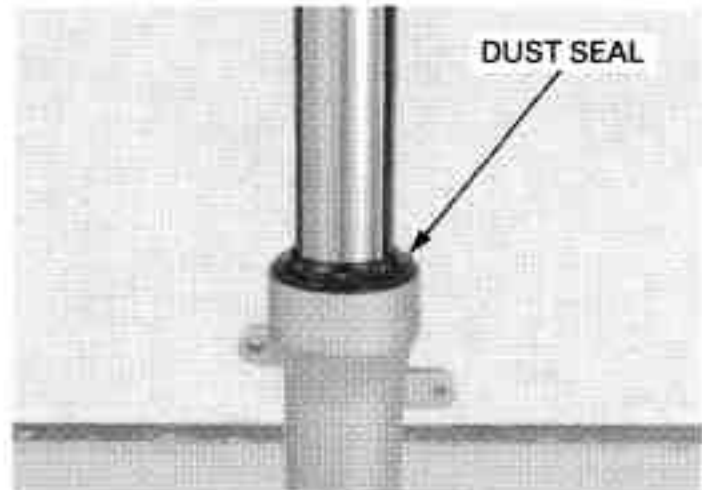

Install the fork protector over the fork slider with the pawls aligned with the slider grooves as shown.

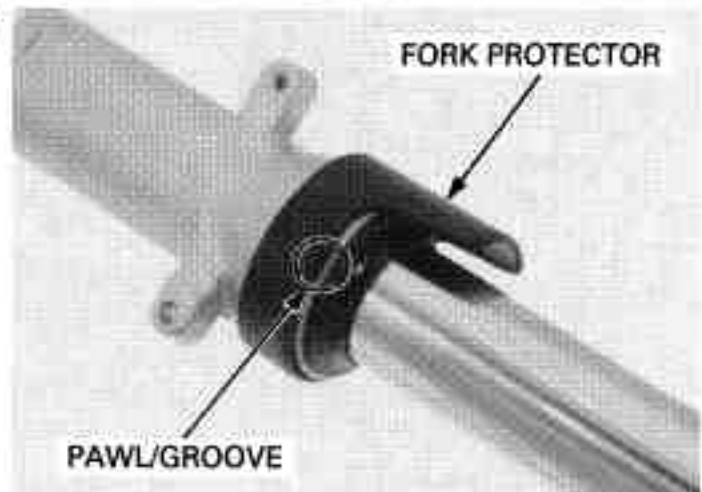

Apply a locking agent to the fork socket bolt threads.
Install the socket bolt with a new sealing washer.



Hold the fork slider in a vise with soft jaws or a shop towel.

If the fork piston turns together with the socket bolt, temporarily install the spring collar, fork spring, spring seat, distance collar, spacer and fork cap.

Tighten the fork socket bolt to the specified torque.

TORQUE: 20 N·m (2.0 kgf·m, 14 lbf·ft)

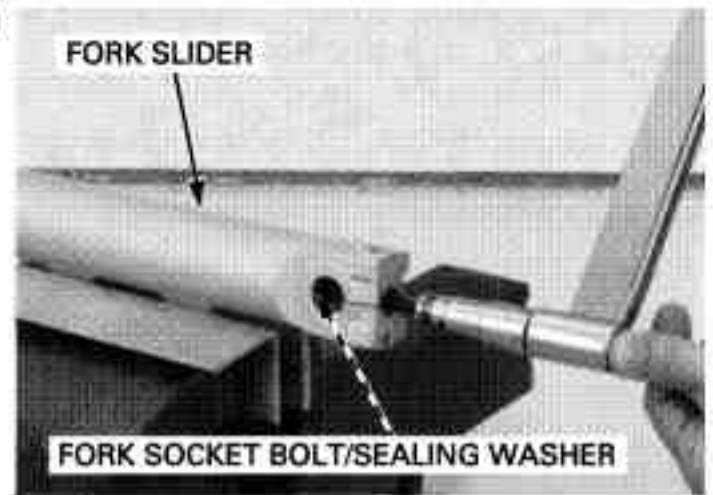

Install the axle holder bolt to the fork slider, but do not tighten yet.

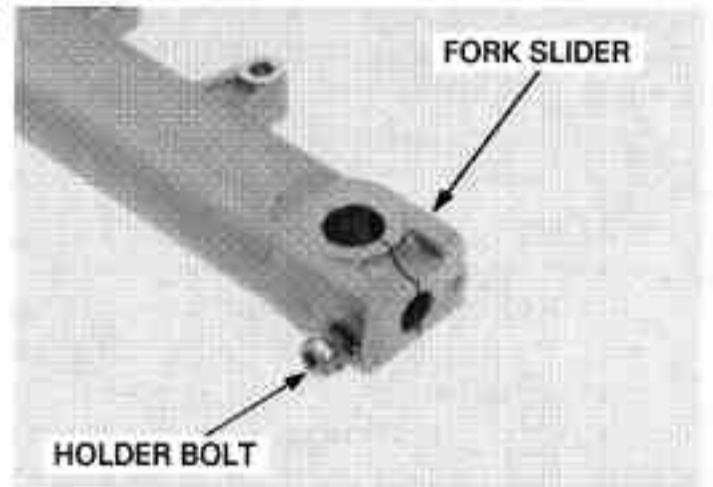

Install the spring collar with its "UP" mark facing up.

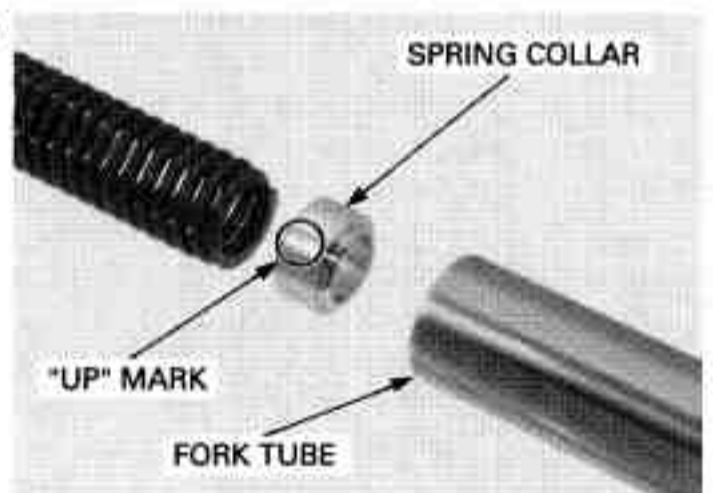

Pour the specified amount of recommended fork fluid into the fork tube.

RECOMMENDED FORK FLUID:

Pro Honda suspension fluid SS-8

FORK FLUID CAPACITY:

$447 \pm 2.5 \text{ cm}^3$ (15.1 \pm 0.08 US oz, 15.7 \pm 0.09 Imp oz)

Pump the fork tube several times.

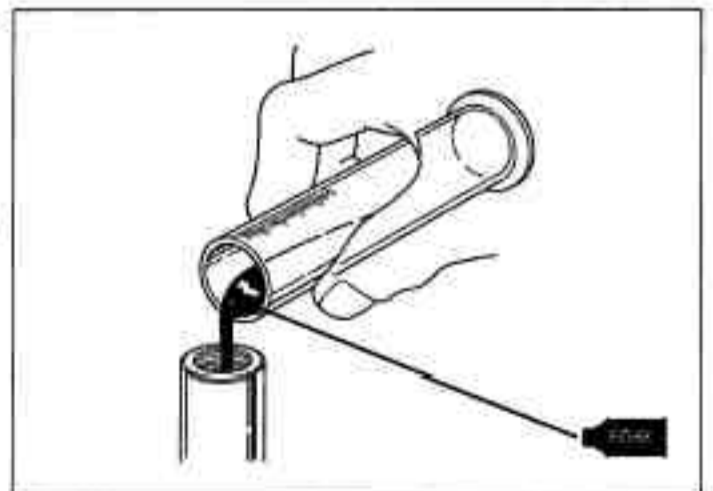

FRONT WHEEL/SUSPENSION/STEERING

Be sure the oil level is the same in the both forks.

Measure the oil level from the top of the fork tube while compressing the fork tube all the way after stroking the fork tube slowly more than 5 times.

FORK OIL LEVEL: 140 mm (5.5 in)

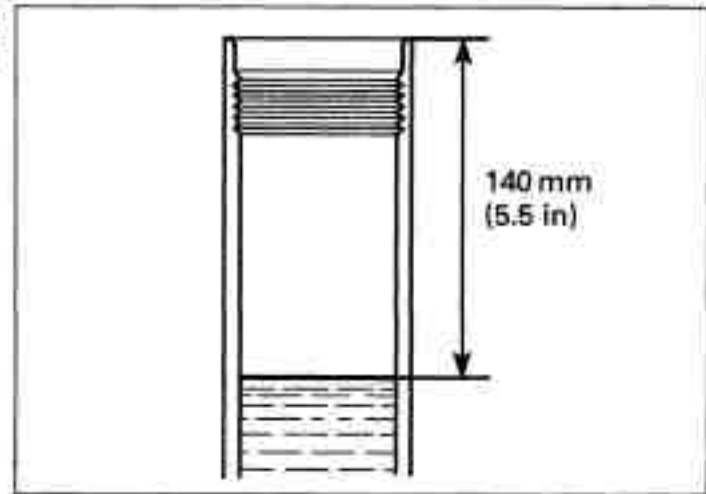

Pull the fork tube up and install the fork spring with the tightly wound coil end facing down.

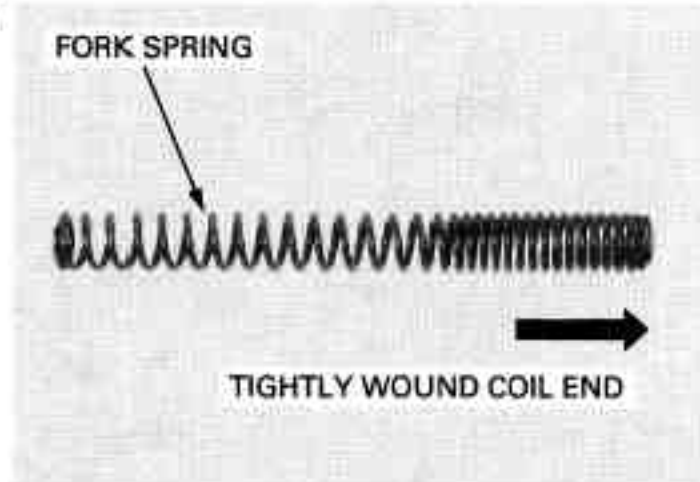

Install the spring seat and distance collar.

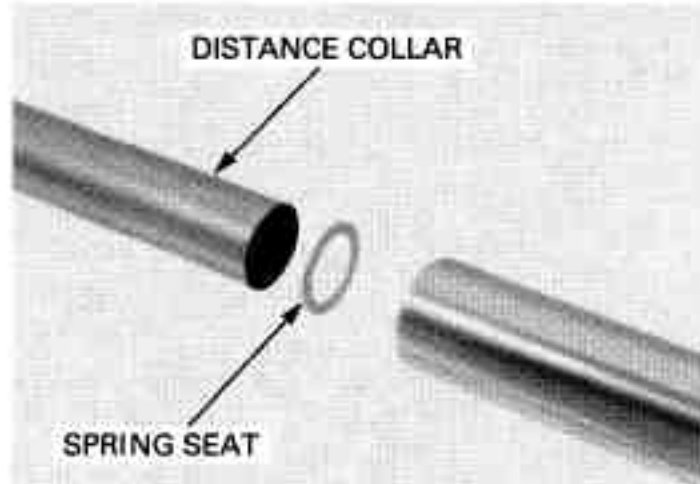

Install the spacer.
Install new O-ring onto the fork cap.
Apply fork fluid to the new O-ring.

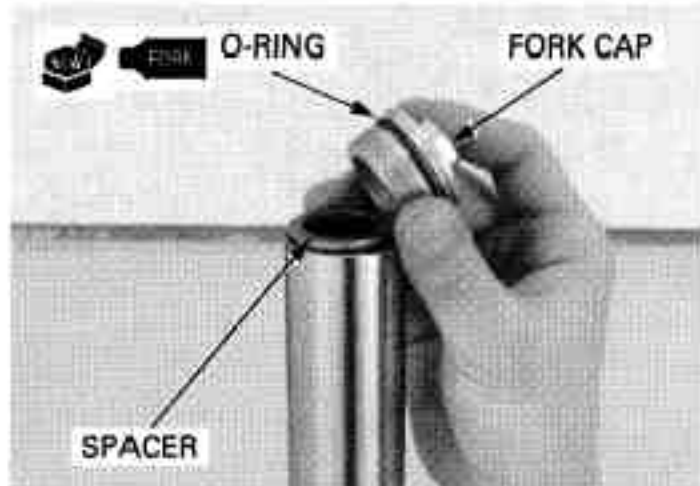

Install the fork cap into the fork tube.

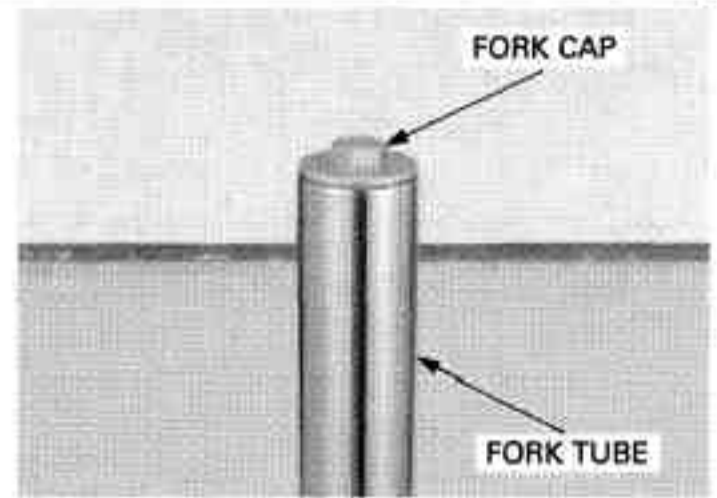

ASSEMBLY (After '04 model)

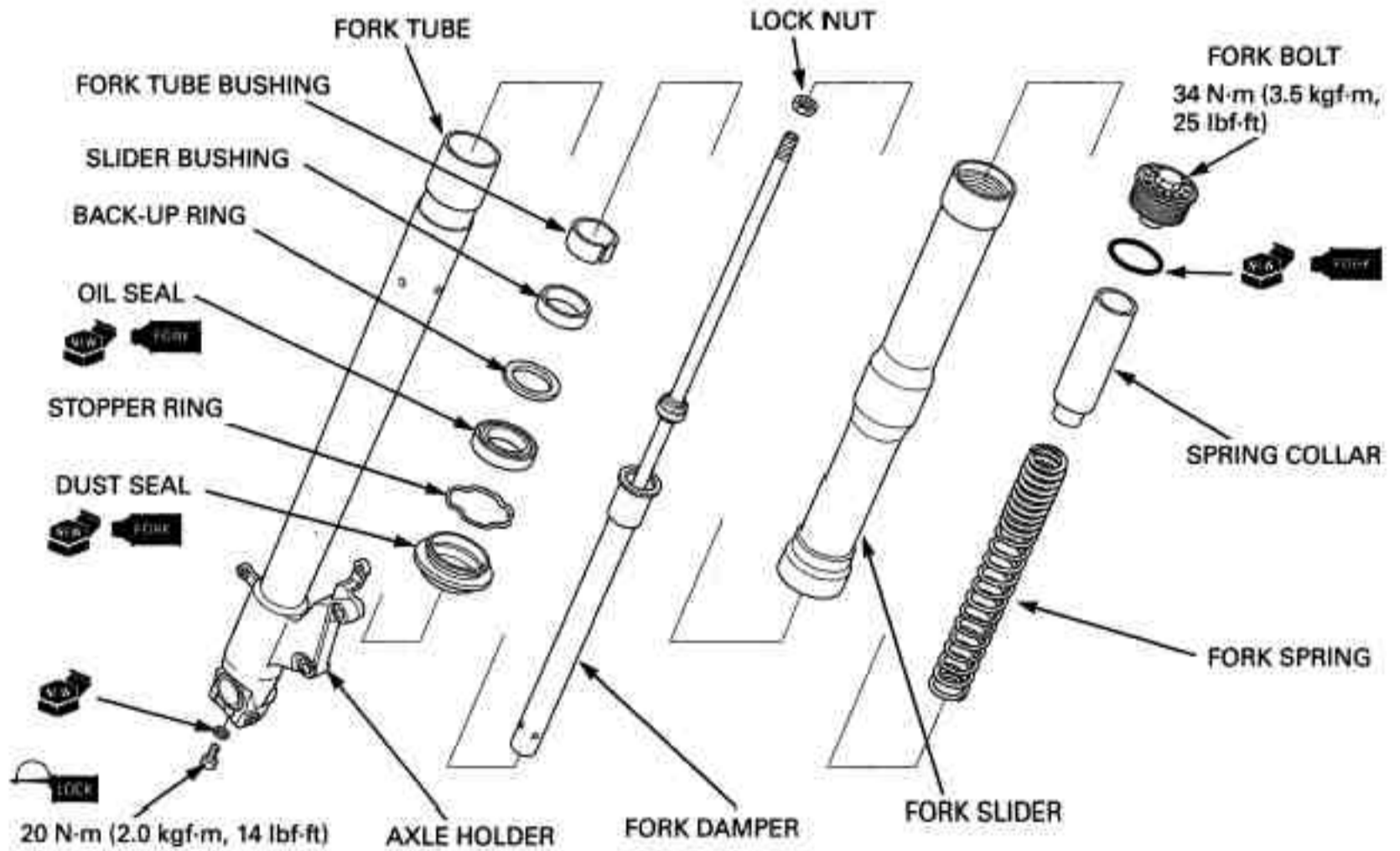

- Before assembly, wash all parts with a high flash or non-flammable solvent and wipe them dry.
- When installing the fork dust seal and the oil seal, wrap the edge and groove of the fork tube with a tape.

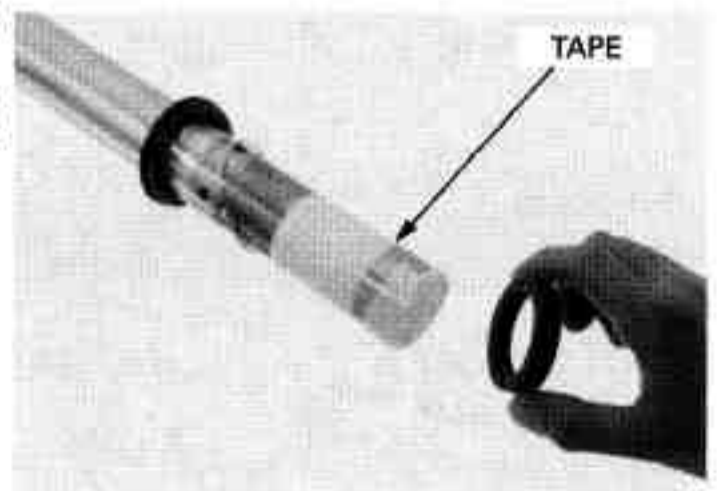

FRONT WHEEL/SUSPENSION/STEERING

Apply fork fluid to a new dust seal and oil seal lips.

Install the oil seal with its marked side facing toward the axle holder.

Install the dust seal, stopper ring and oil seal.

Remove the burrs from the slider bushing mating surface, being careful not to peel off the coating.

Install the back-up ring, slider bushing and fork tube bushing.

Install the fork tube into the fork slider.

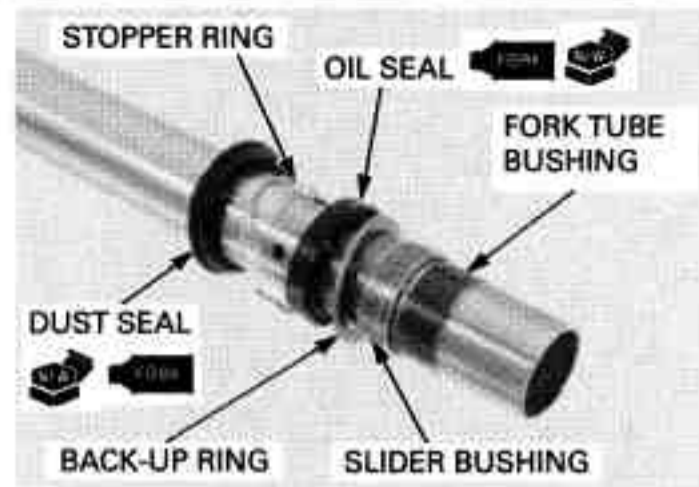

Drive the oil seal in using the special tools.

TOOLS:

Fork seal driver weight 07KMD-KZ30100
Oil seal driver attachment 07RMD-MW40100

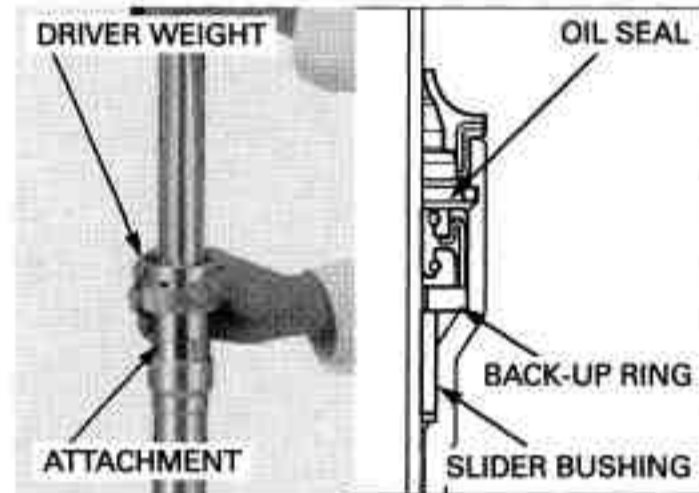

Install the stopper ring into the fork slider groove securely.

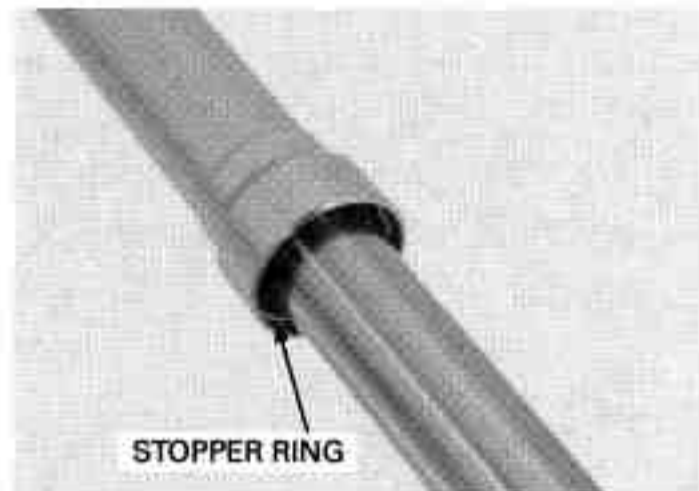

Install the dust seal.

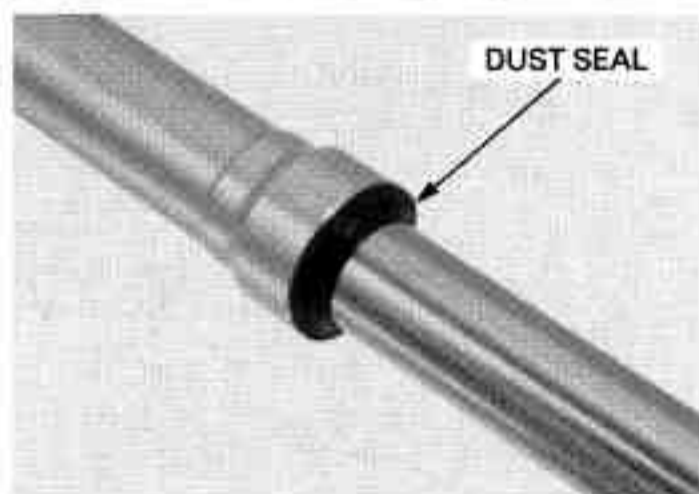

Install the fork damper into the fork slider.

Apply a locking agent to the fork socket bolt threads.

Install the socket bolt with a new sealing washer.

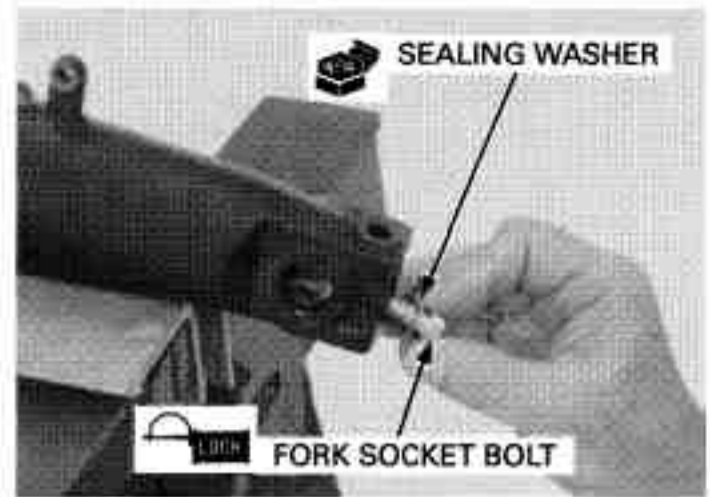

Hold the axle holder in a vise with soft jaws or a shop towel.

Hold the fork damper with fork damper holder attachment then tighten the fork socket bolt to the specified torque.

TOOLS:

Fork damper holder attachment 07YMB-MCF0101

TORQUE: 20 N·m (2.0 kgf·m, 14.4 lbf·ft)



Pour the specified amount of recommended fork fluid into the fork slider.

RECOMMENDED FORK FLUID:

Honda Ultra Cushion Oil 10W or equivalent

FORK FLUID CAPACITY:

483 ± 2.5 cm³

(16.36 ± 0.08 US oz, 17.00 ± 0.09 Imp oz)

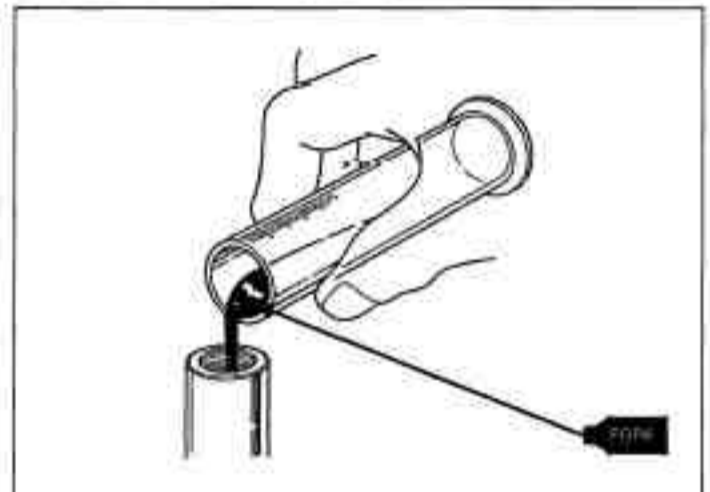

Bleed the air from the fork leg as follows.

1. Extend the fork, cover the top of the fork slider with your hand and compress the fork leg slowly.
2. Remove your hand and extend the fork slowly.
Repeat above procedure 2 or 3 times.
3. Pump the fork damper rod slowly 8 - 10 times.

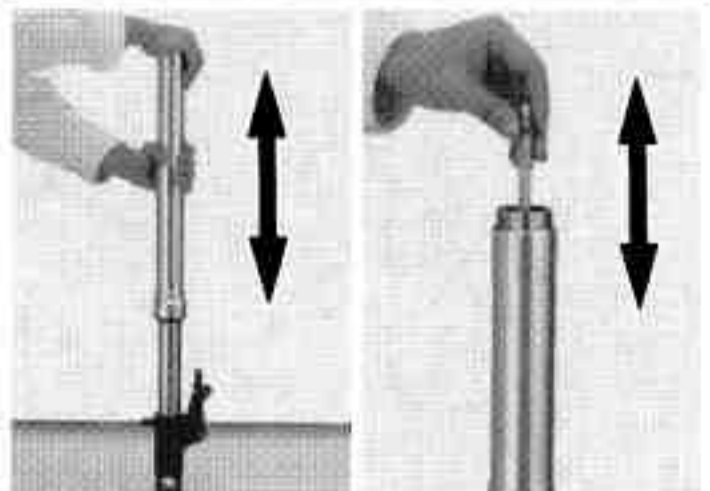

FRONT WHEEL/SUSPENSION/STEERING

Be sure that the oil level is the same in the both forks.

Slowly push the slider, gently seat the dust seal onto axle holder and leave it for 5 minutes.

After the oil level stabilizes, measure the oil level from top of the fork tube.

FORK OIL LEVEL: 77 mm (3.0 in)

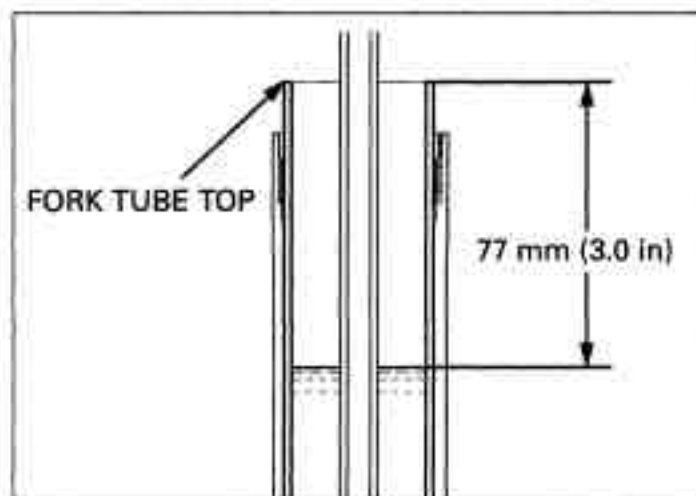

Pull the fork tube up and install the fork spring with the tapered end facing up.

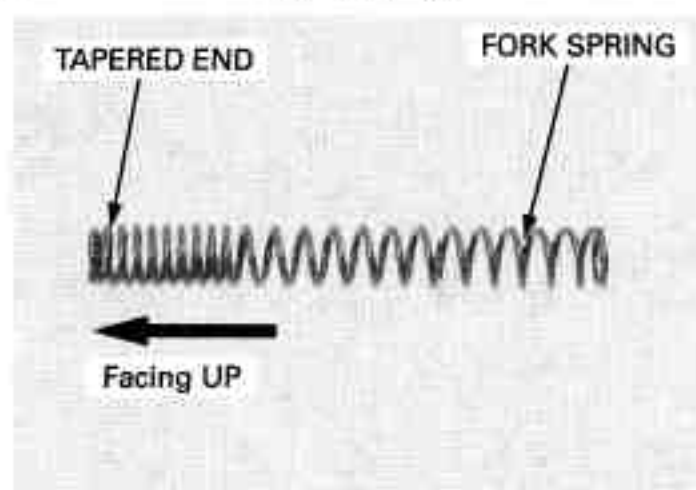

Attach the fork damper holder to the fork damper.

TOOLS:

Fork damper holder 070MF-MBZC120

Install the fork spring collar.

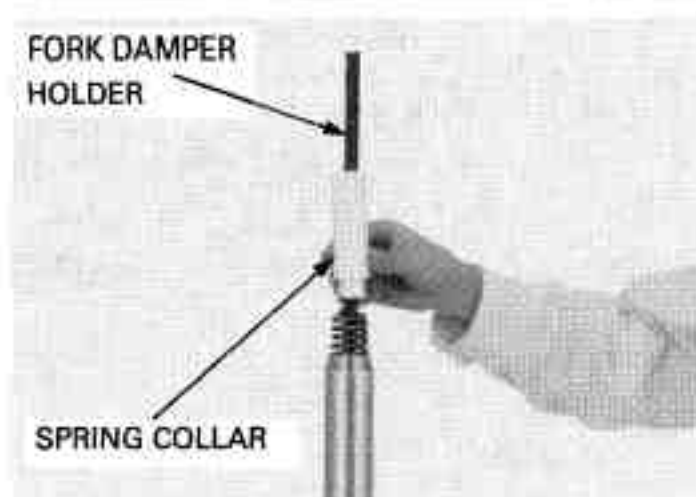

Set the spring collar holder to the spring collar holes.

TOOLS:

Spring collar holder 070MF-MBZC110

Compress the spring collar with the spring collar holder while pulling up the fork damper holder. Install the stopper plate between the nut and the spring collar.

TOOLS:

Stopper plate 070MF-MBZC130

Remove the fork damper holder.

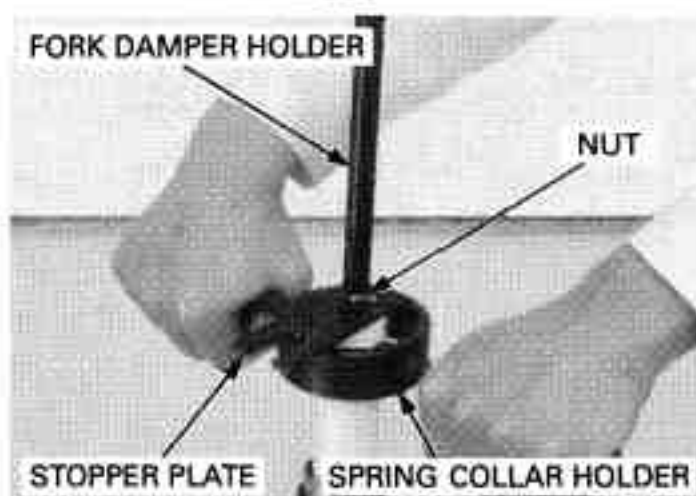

Apply fork fluid to a new O-ring and install it to the fork bolt.

Install the front fork bolt to the fork damper.

Tighten the lock nut to the specified torque with holding the fork bolt.

TORQUE: 20 N-m (2.0 kgf-m, 14.4 lbf-ft)

Remove the stopper plate and the spring collar holder.

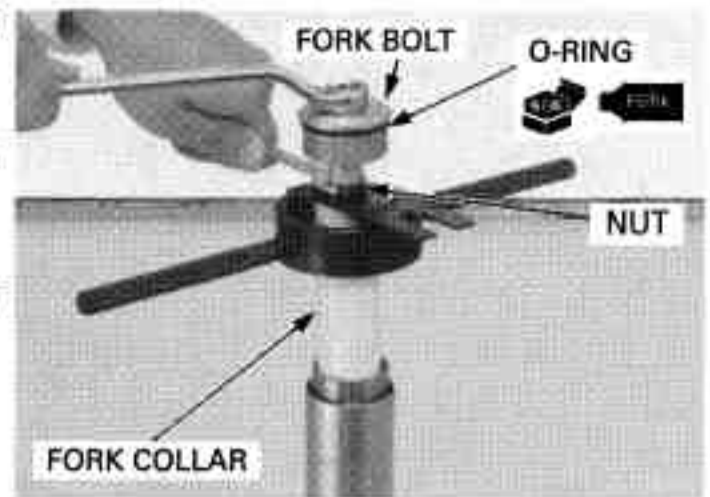

Install the front fork bolt to the fork slider.

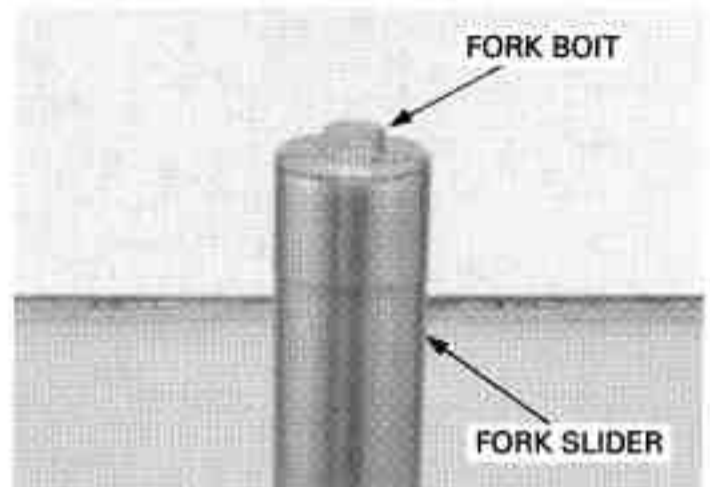

INSTALLATION

Install the fork leg through the steering stem and top bridge.

Align the top end of the fork tube with the upper surface of the top bridge as shown.

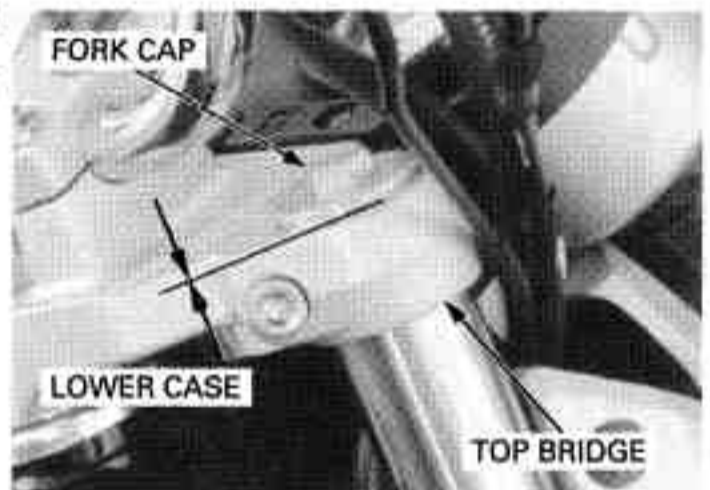

Tighten the bottom bridge pinch bolt to the specified torque.

TORQUE: 39 N-m (4.0 kgf-m, 29 lbf-ft)

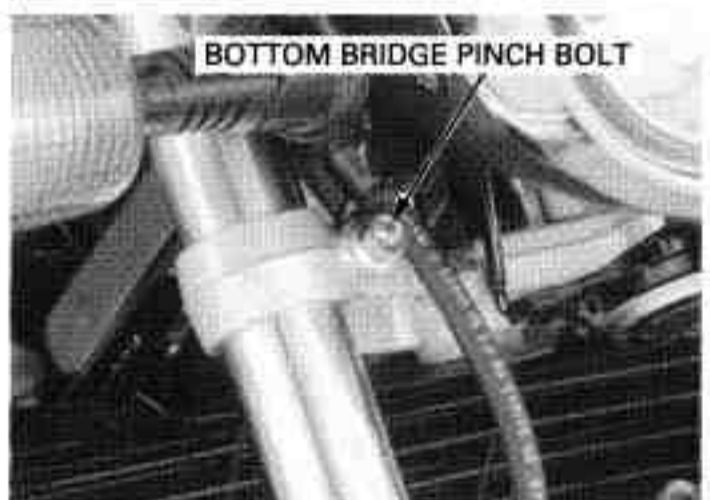

FRONT WHEEL/SUSPENSION/STEERING

'04 model only: Tighten the fork cap to the specified torque if it was removed.

TORQUE: 23 N·m (2.3 kgf·m, 17 lbf·ft)

Tighten the top bridge pinch bolt to the specified torque.

TORQUE: 23 N·m (2.3 kgf·m, 17 lbf·ft)

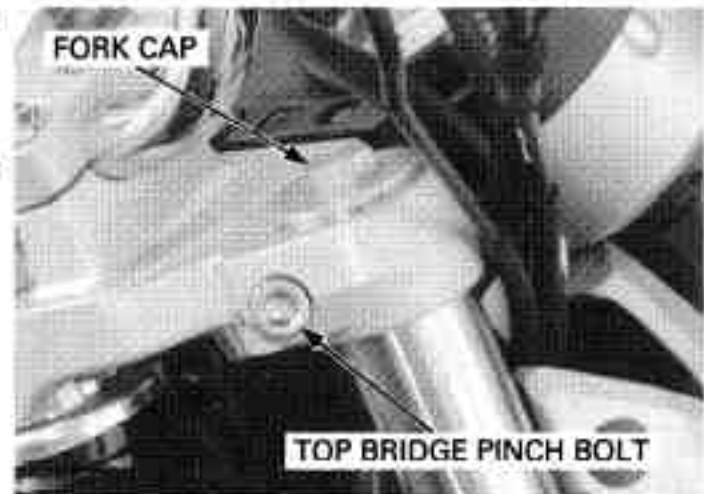

After '04 model only: Tighten the fork bolt to the specified torque if it was removed.

TORQUE: 34 N·m (3.5 kgf·m, 25 lbf·ft)

Tighten the top bridge pinch bolt to the specified torque.

TORQUE: 23 N·m (2.3 kgf·m, 17 lbf·ft)

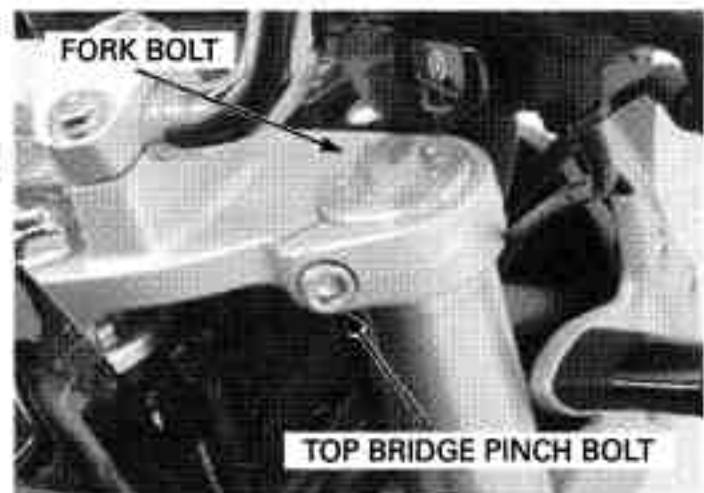

Install the front fender, socket bolts, reflector and bolts (page 3-7).

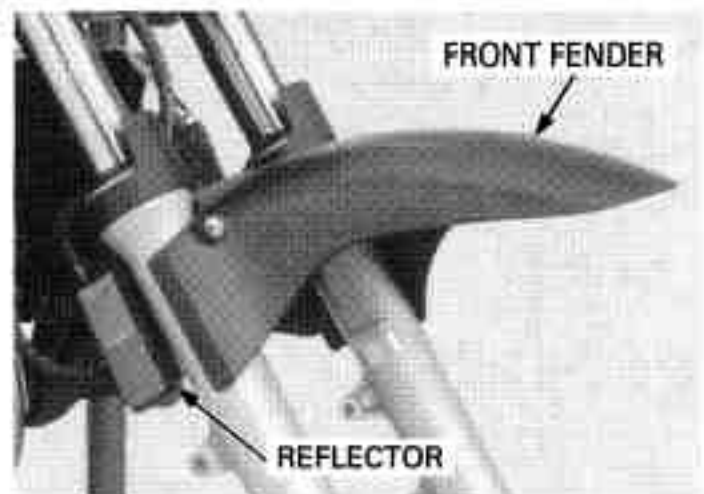

Right side only: Install the right brake caliper and tighten the new mounting bolts to the specified torque.

TORQUE: 30 N·m (3.1 kgf·m, 22 lbf·ft)

Install the front wheel (page 14-19).

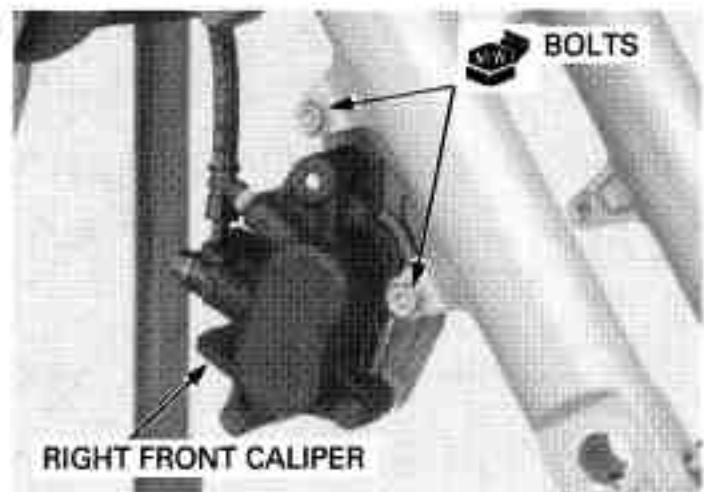

STEERING STEM**REMOVAL**

Remove the following:

- Handlebar (page 14-8)
- Front wheel (page 14-15)
- Headlight case (page 20-7)
- Combination meter (page 20-9)
- Horn ('04 model only) (page 20-30)
- Meter visor (After '04 model only) (page 3-8)

Remove the bolt and front brake hose clamp.

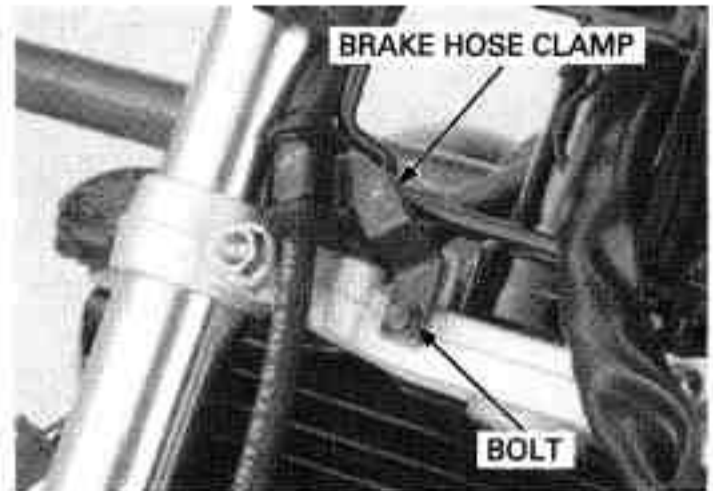

Remove the steering stem nut and washer.

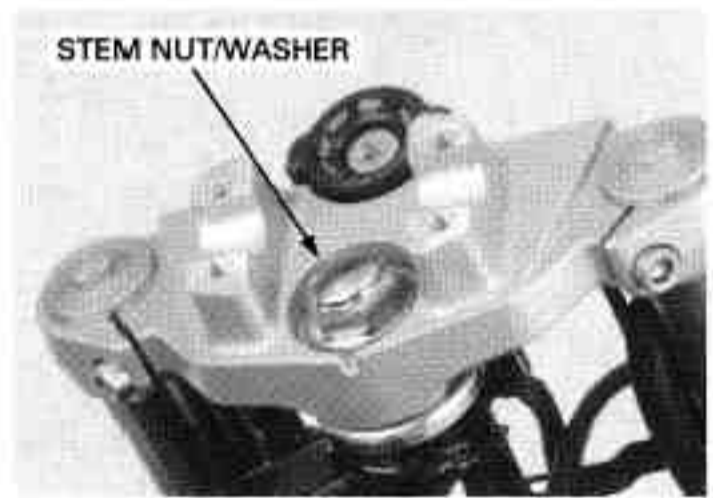

Loosen the fork top bridge pinch bolts and remove the top bridge.

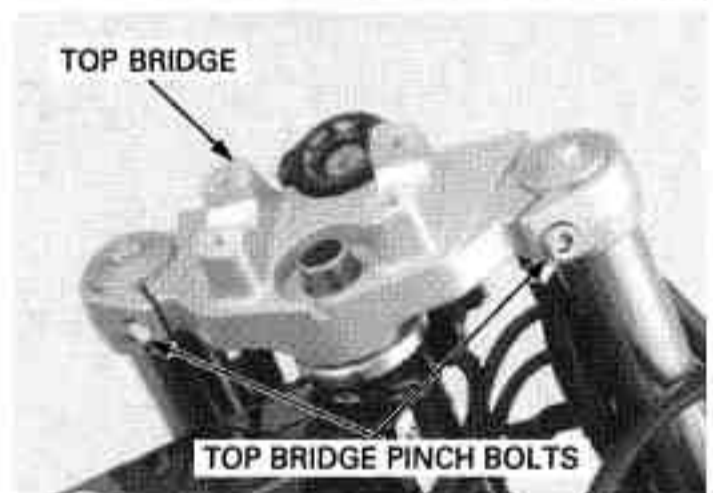

Remove the headlight case bracket assembly from the steering stem.

Remove the forks (page 14-21).



FRONT WHEEL/SUSPENSION/STEERING

Straighten the tabs of the lock washer.

Remove the steering bearing adjustment nut lock nut and lock washer.

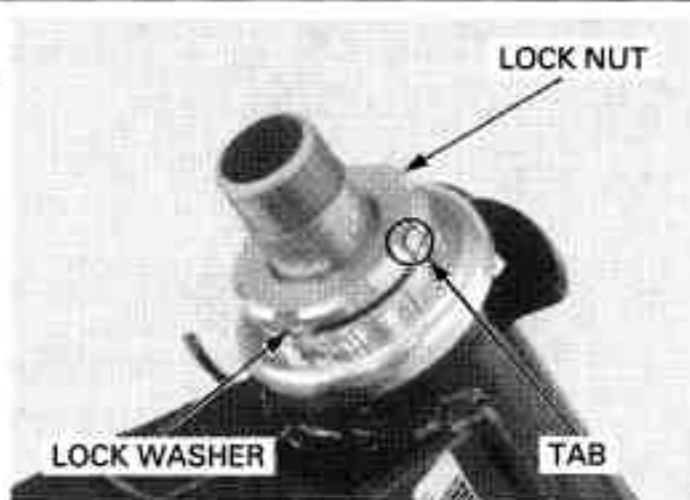

Remove the steering stem bearing adjustment nut using the special tool.

TOOL:

Steering stem socket 07916-3710101 or
07916-3710100 (U.S.A. only)

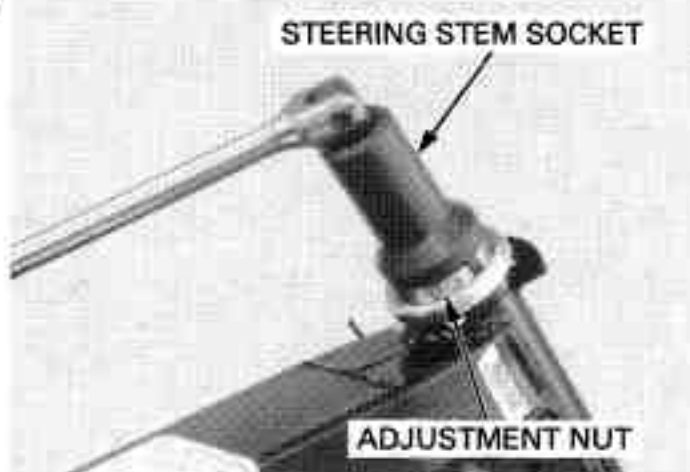

Remove the following:

- Dust seal
- Upper bearing inner race
- Upper bearing

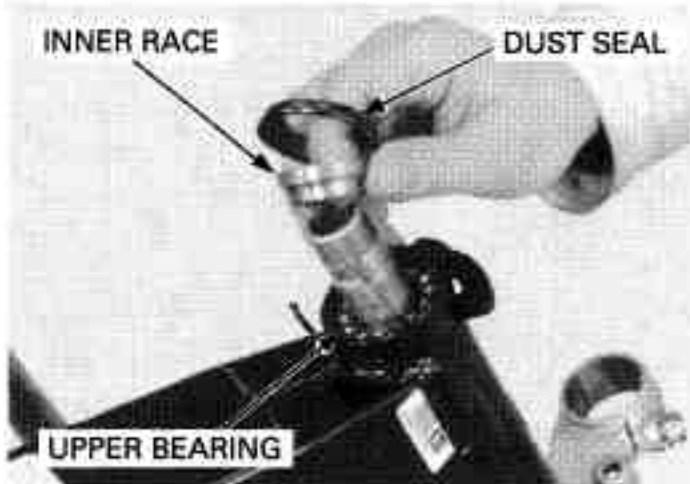

Remove the following:

- Steering stem
- Lower bearing

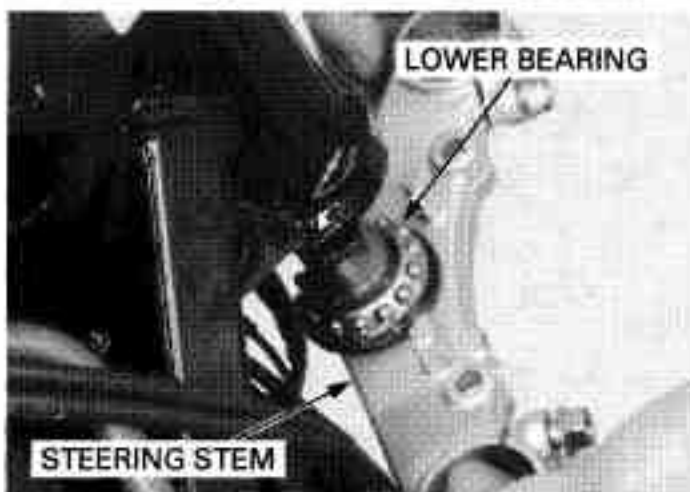

BEARING REPLACEMENT

Always replace the bearings and races as a set.

Remove the upper bearing outer races using the special tools.

TOOLS:

- Driver attachment** 07953-MJ10100 or
- Race remover** 07953-MJ1010B (U.S.A. only) or 07953-MJ1010A (U.S.A. only)
- Driver handle** 07953-MJ10200

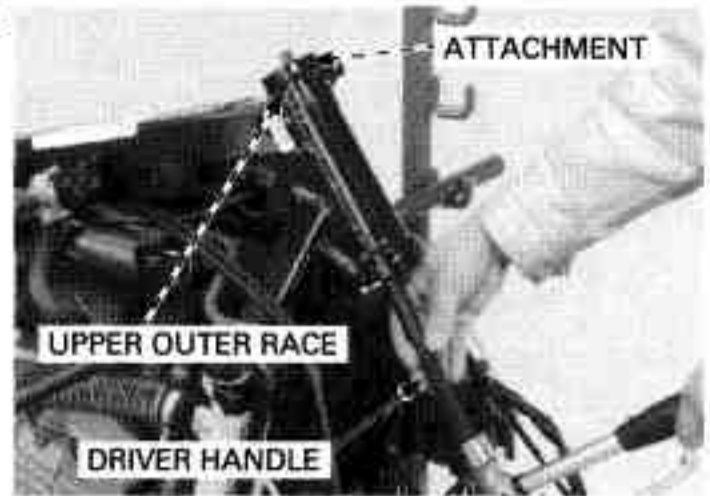

Remove the lower bearing outer races using the special tools.

TOOL:

- Bearing race remover** 07946-3710500

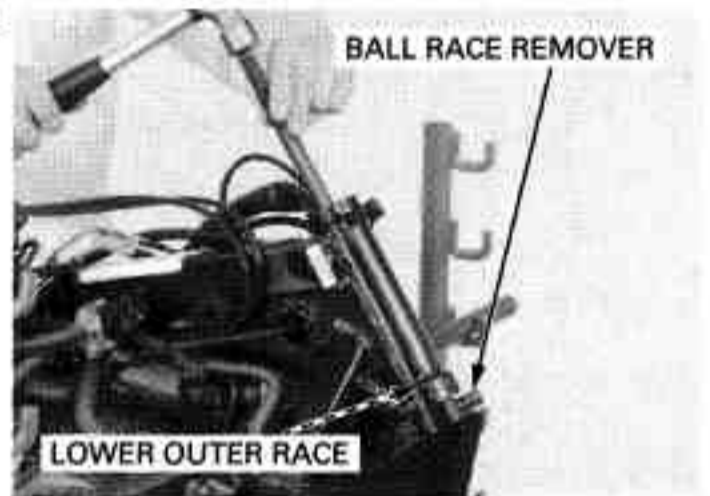

Temporarily install the steering stem nut onto the stem to prevent the threads from being damaged when removing the lower bearing inner race from the stem.

Remove the lower bearing inner race with a chisel or equivalent tool, being careful not to damage the stem.

Remove the dust seal.

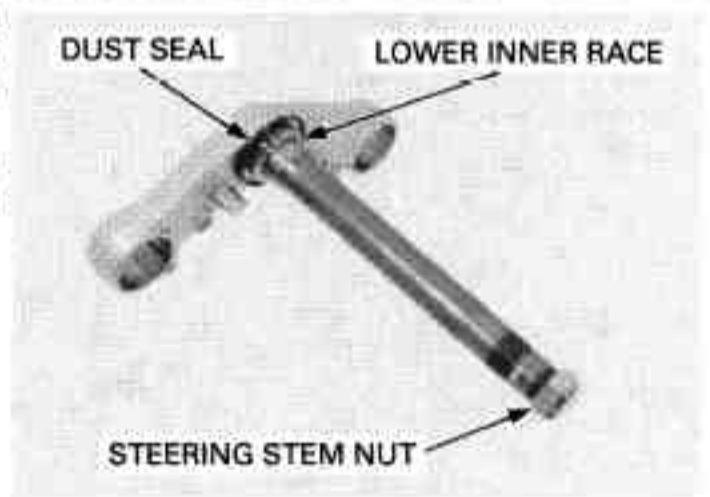

Apply grease to a new dust seal lips and install it over the steering stem.

Install a new lower bearing inner race using a special tool and a hydraulic press.

TOOL:

- Steering stem driver** 07946-MB00000

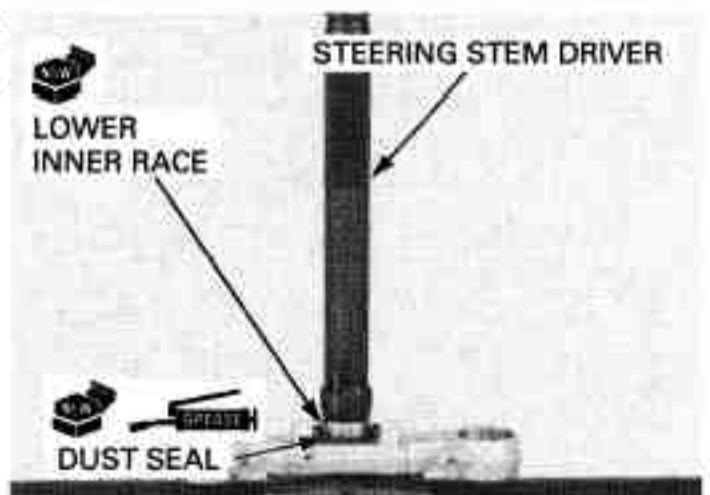

FRONT WHEEL/SUSPENSION/STEERING

Drive a new lower bearing outer race into the steering head pipe.

TOOLS:

Driver 07749-0010000
Attachment, 52 X 55 mm 07746-0010400

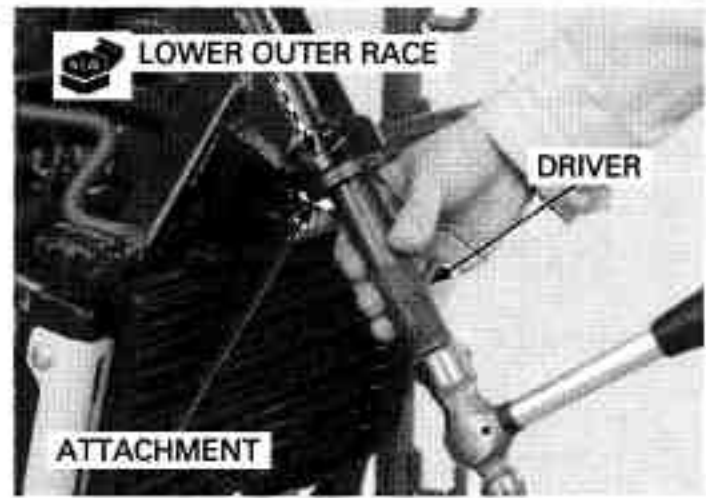

Drive a new upper bearing outer race into the steering head pipe.

TOOLS:

Driver 07749-0010000
Attachment, 42 X 47 mm 07746-0010300

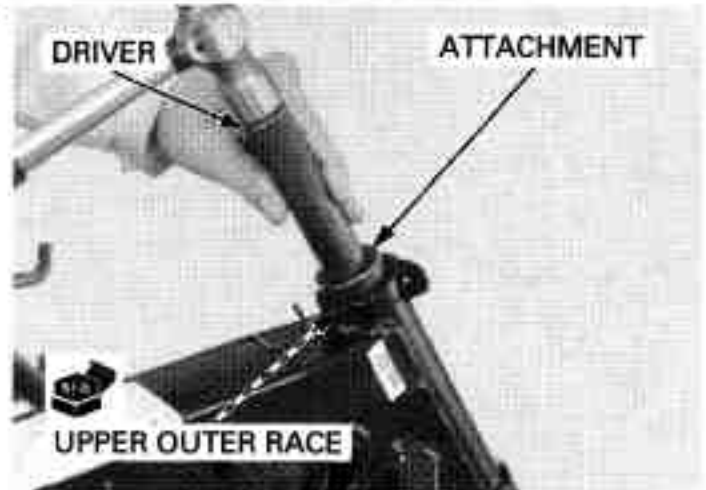

INSTALLATION

'04 model:

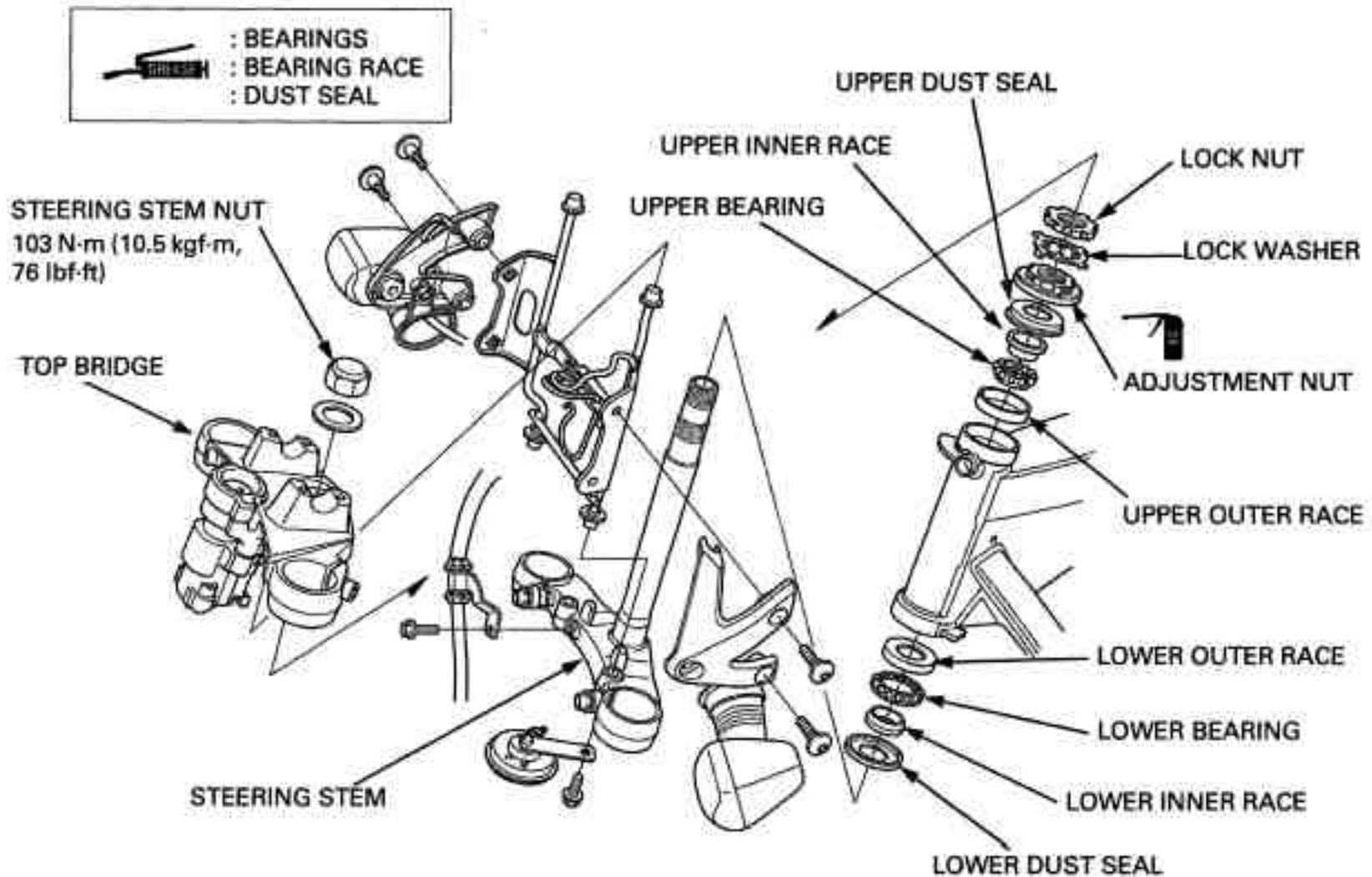

After '04 model:

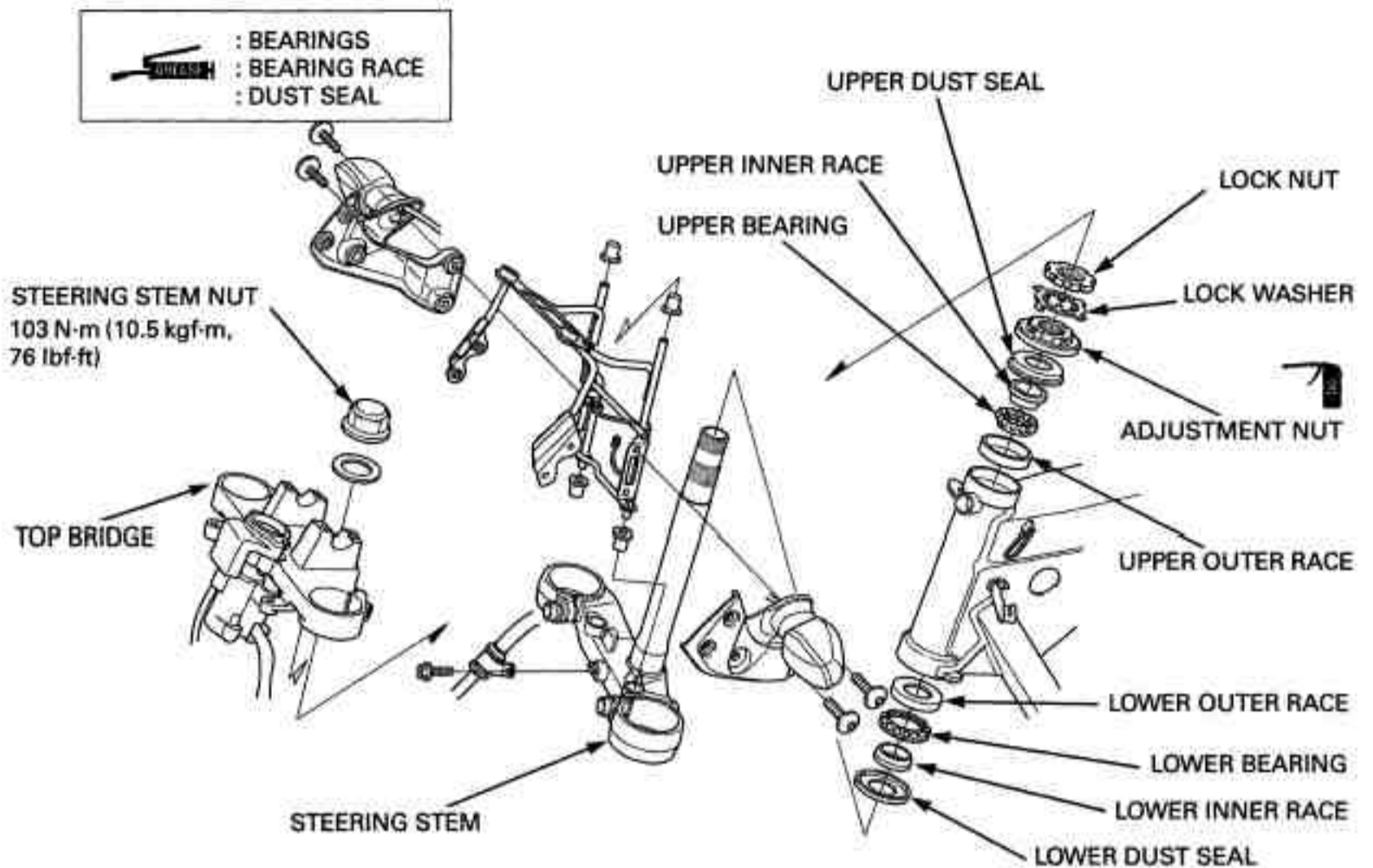

Apply grease to upper and lower bearings and bearing races.

Install the lower bearing onto the steering stem. Insert the steering stem into the steering head pipe.

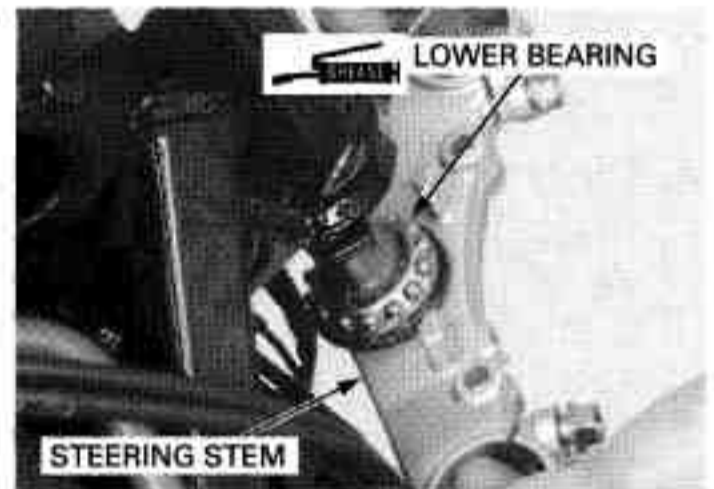

Install upper bearing, inner race and dust seal.

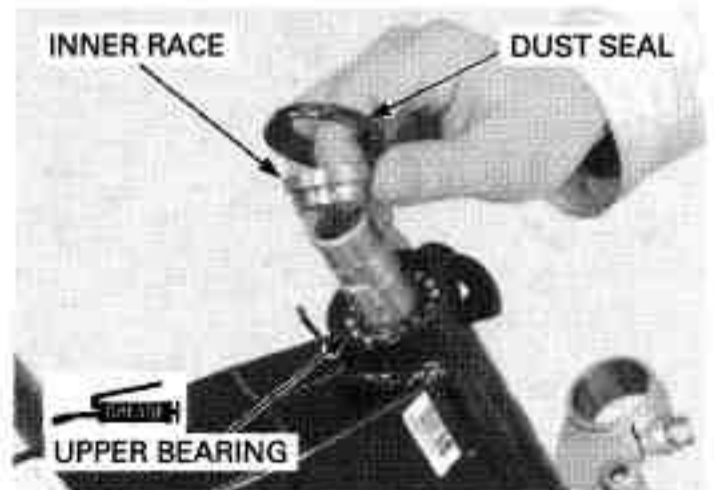

FRONT WHEEL/SUSPENSION/STEERING

Apply oil to the bearing adjustment nut threads. Install and tighten the stem bearing adjustment nut to the initial torque.

TOOL:

Steering stem socket 07916-3710101 or
07916-3710100 (U.S.A. only)

TORQUE: 27 N-m (2.8 kgf-m, 20 lbf-ft)

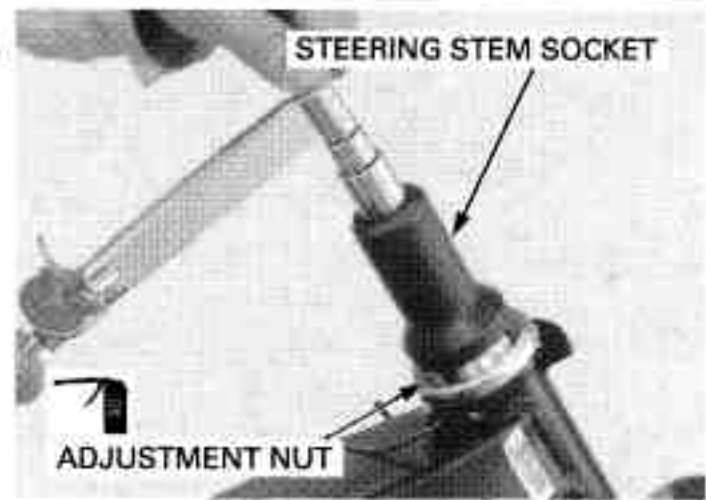

Move the steering stem right and left, lock-to-lock, five times to seat the bearings. Make sure that the steering stem moves smoothly, without play or binding.

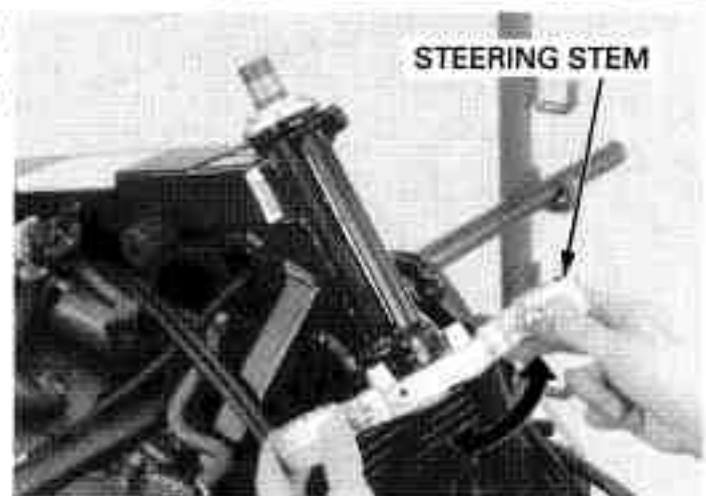

Retighten the bearing adjusting nut to the specified torque.

TOOL:

Steering stem socket 07916-3710101 or
07916-3710100 (U.S.A. only)

TORQUE: 27 N-m (2.8 kgf-m, 20 lbf-ft)

Recheck that the steering stem moves smoothly without play or binding.

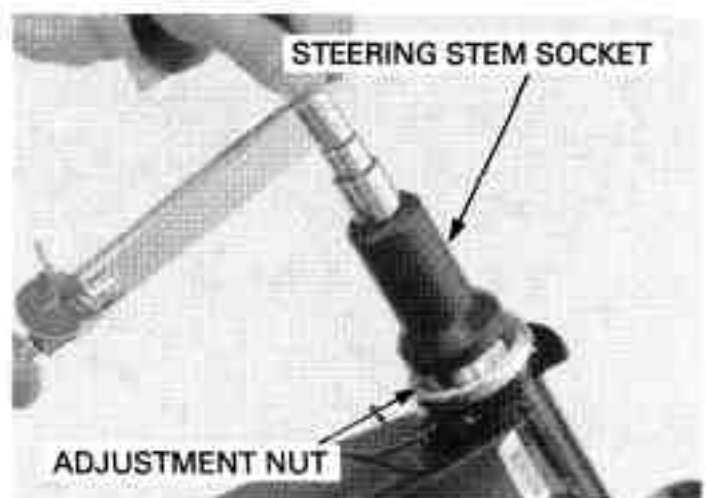

Install the new lock washer onto the steering stem.

Align the tabs of the lock washer with the grooves in the adjustment nut and bend two opposite tabs (shorter) down into the adjustment nut groove.



Do not over tighten the lock nut until lock washer being flat.

Install and finger tighten the lock nut, further finger tighten the lock nut within 1/4 turn (90°) enough to align its grooves with the lock washer tabs.

Bend the lock washer tabs up into the lock nut groove.

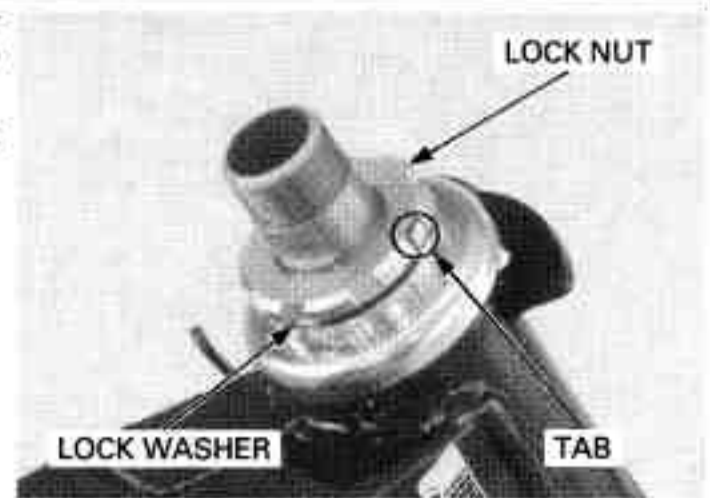

Install the fork legs (page 14-39).

Route the wires, cables properly (page 1-23).

Install the headlight case bracket with its rubber grommets to the holes on the steering stem.

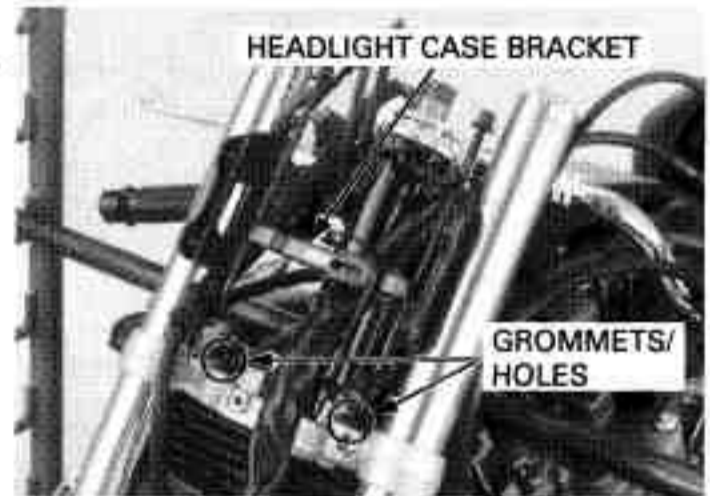

Install the top bridge with its holes to the grommets of the headlight case bracket.



Install the washer and steering stem nut. Tighten the steering stem nut to the specified torque.

TORQUE: 103 N·m (10.5 kgf·m, 76 lbf·ft)



FRONT WHEEL/SUSPENSION/STEERING

Install the front brake hose clamp, tighten the bolt securely.

Install the following;

- Handlebar (page 14-10)
- Front wheel (page 14-19)
- Headlight case (page 20-7)
- Combination meter (page 20-12)
- Horn ('04 model) (page 20-30)
- Meter visor (After '04 model only) (page 3-8)

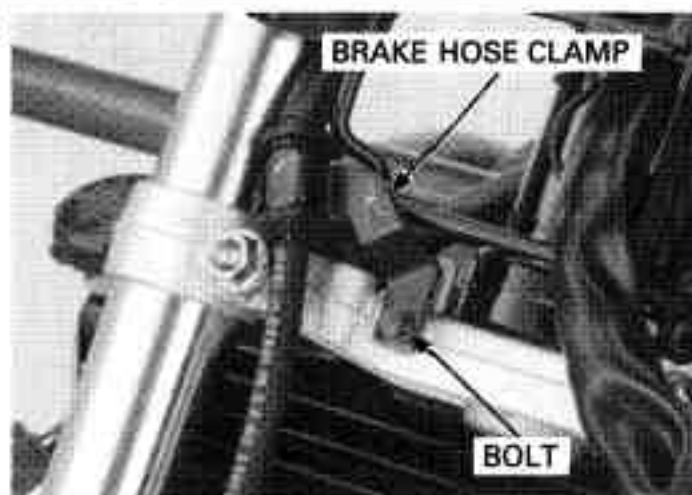

STEERING HEAD BEARING PRE-LOAD

Jack-up the motorcycle to raise the front wheel off the ground.

Position the steering stem to the straight ahead position.

Hook a spring scale to the fork tube and measure the steering head bearing pre-load.

The pre-load should be within 0.9 – 1.3 kgf (2.0 – 2.9 lbf).

If the readings do not fall within the limits, lower the front wheel to the ground and adjust the steering bearing adjusting nut.

Make sure that there is no cable or wire harness interference.

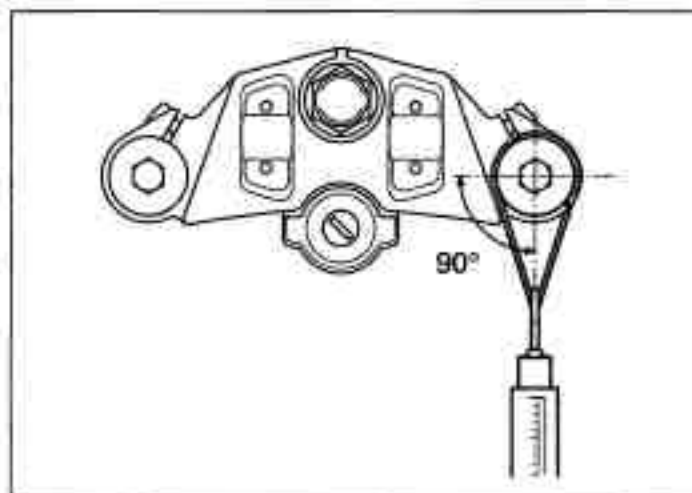

15. REAR WHEEL/SUSPENSION

COMPONENT LOCATION	15-2	REAR WHEEL	15-6
SERVICE INFORMATION	15-3	SHOCK ABSORBER	15-13
TROUBLESHOOTING	15-5	SWINGARM	15-15

REAR WHEEL/SUSPENSION

COMPONENT LOCATION

'04 model shown:

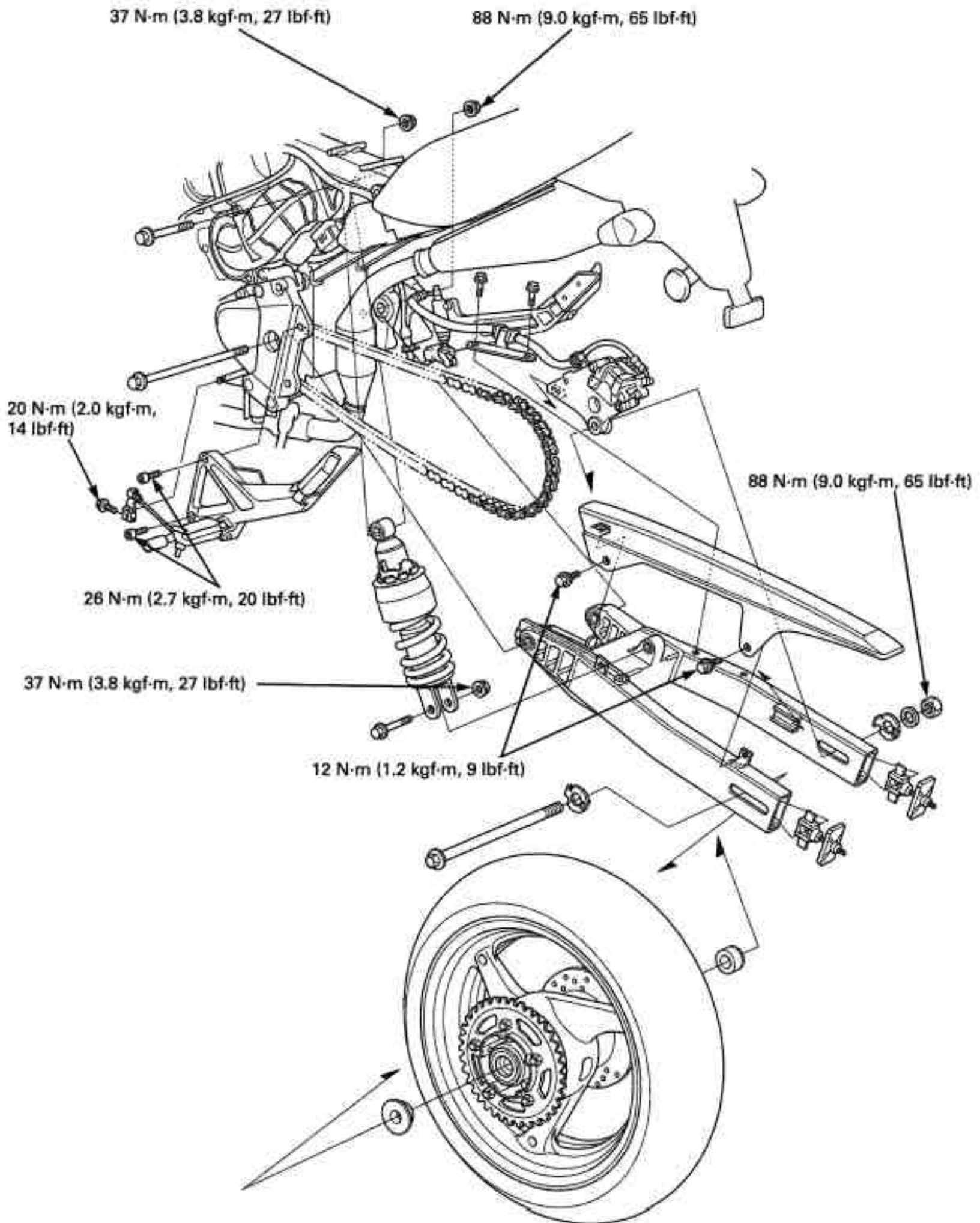

SERVICE INFORMATION

GENERAL

- A contaminated brake disc or pad reduces stopping power. Discard contaminated pads and clean a contaminated disc with a high quality brake degreasing agent.
- After the rear wheel installation, check the brake operation by applying the brake pedal.
- The shock absorber contains nitrogen under high pressure. Do not allow fire or heat near the shock absorber.
- Before disposal of the shock absorber, release the nitrogen (page 15-14).
- When servicing the rear wheel and suspension, support the motorcycle using a safety stand or hoist.
- Use only tires marked "TUBELESS" and tubeless valves on rim marked "TUBELESS TIRE APPLICABLE".
- Use genuine Honda replacement bolts and nuts for all suspension pivot and mounting point.
- Refer to the brake system information (page 16-4).

SPECIFICATIONS

Unit: mm (in)











ITEM		STANDARD		SERVICE LIMIT
Minimum tire tread depth		-		2.0 (0.08)
Cold tire pressure	Driver only	290 kPa (2.90 kgf/cm ² , 42 psi)		-
	Driver and passenger	290 kPa (2.90 kgf/cm ² , 42 psi)		-
Axle runout		-		0.2 (0.01)
Wheel rim runout	Radial	-		2.0 (0.08)
	Axial	-		2.0 (0.08)
Wheel balance weight		-		60 g (2.1 oz) max.
Drive chain	Size/link	DID	525VM2-110LE	-
		RK	525RO-110LE	-
	Slack	30 - 40 (1.2 - 1.6)		50 (2.0)
Shock absorber pre-load adjuster standard position		2nd groove		-

TORQUE VALUES

Rear axle nut	88 N·m (9.0 kgf·m, 65 lbf·ft)	U-nut
Rear brake disc mounting bolt	42 N·m (4.3 kgf·m, 31 lbf·ft)	ALOC bolt: replace with a new one
Final driven sprocket nut	108 N·m (11.0 kgf·m, 80 lbf·ft)	U-nut
Swingarm pivot nut	88 N·m (9.0 kgf·m, 65 lbf·ft)	U-nut
Drive chain case bolt	12 N·m (1.2 kgf·m, 9 lbf·ft)	
Drive chain slider bolt	8.8 N·m (0.90 kgf·m, 6.5 lbf·ft)	
Drive chain adjuster lock nut	21 N·m (2.1 kgf·m, 15 lbf·ft)	
Rear shock absorber upper mounting nut	37 N·m (3.8 kgf·m, 27 lbf·ft)	U-nut
Rear shock absorber lower mounting nut	37 N·m (3.8 kgf·m, 27 lbf·ft)	U-nut
Footpeg holder bolt	26 N·m (2.7 kgf·m, 20 lbf·ft)	
Gearshift pedal link bolt (gearshift spindle side)	20 N·m (2.0 kgf·m, 14 lbf·ft)	

REAR WHEEL/SUSPENSION

TOOLS

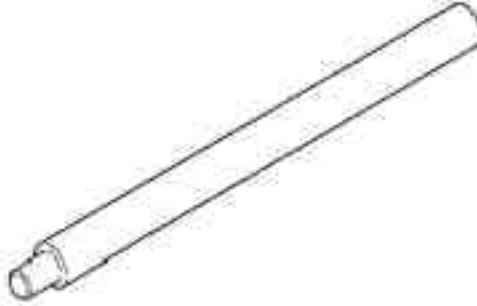
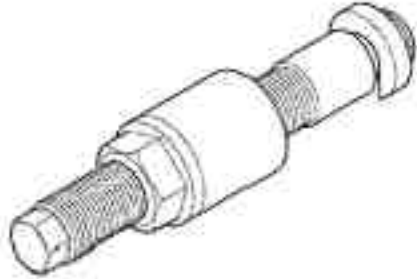
<p>Bearing remover shaft 07GGD-0010100</p>  <p>or 07746-0050100</p>	<p>Bearing remover head, 17 mm 07746-0050500</p> 	<p>Driver 07749-0010000</p> 
<p>Attachment, 32 X 35 mm 07746-0010100</p> 	<p>Attachment, 42 X 47 mm 07746-0010300</p> 	<p>Attachment, 52 X 55 mm 07746-0010400</p> 
<p>Attachment, 24 X 26 mm 07746-0010700</p> 	<p>Pilot, 15 mm 07746-0040300</p> 	<p>Pilot, 17 mm 07746-0040400</p> 
<p>Pilot, 22 mm 07746-0041000</p> 	<p>Driver shaft 07946-MJ00100</p> 	<p>Needle bearing remover 07LMC-KV30100</p> 

Attachment, 28 X 30 mm
07946-1870100



TROUBLESHOOTING

Soft suspension

- Weak shock absorber spring
- Incorrect suspension adjustment
- Oil leakage from damper unit
- Insufficient tire pressure

Stiff suspension

- Incorrect suspension adjustment
- Damaged rear suspension pivot bearings
- Bent damper rod
- Incorrect swingarm pivot fasteners tightening
- Tire pressure too high

Rear wheel wobbling

- Bent rim
- Worn or damaged rear wheel bearings
- Faulty rear tire
- Unbalanced rear tire and wheel
- Insufficient rear tire pressure
- Faulty swingarm pivot bearings

Rear wheel hard to turn

- Faulty rear wheel bearings
- Bent rear axle
- Rear brake drag
- Drive chain too tight

Rear suspension noise

- Faulty rear shock absorber
- Loose rear suspension fasteners
- Worn rear suspension pivot bearings

REAR WHEEL/SUSPENSION

REAR WHEEL

REMOVAL

Loosen the rear axle nut.

Support the motorcycle using a safety stand or a hoist, raise the rear wheel off the ground.

Loosen the lock nut and drive chain adjusting nut and make a drive chain slack fully.

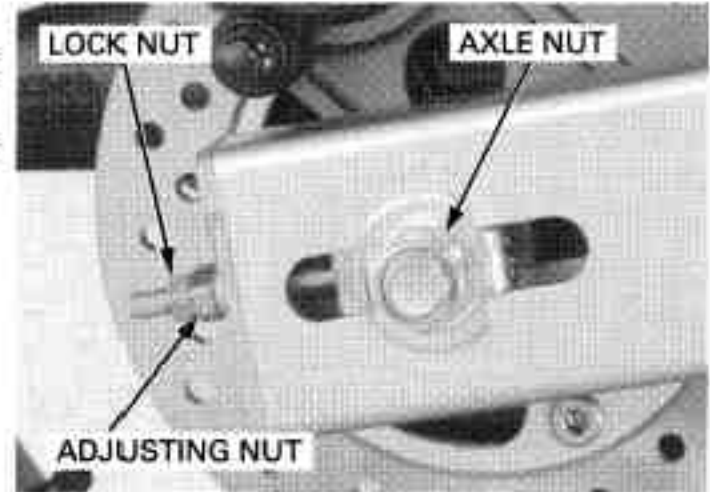

Remove the axle nut, washer and rear axle washer.

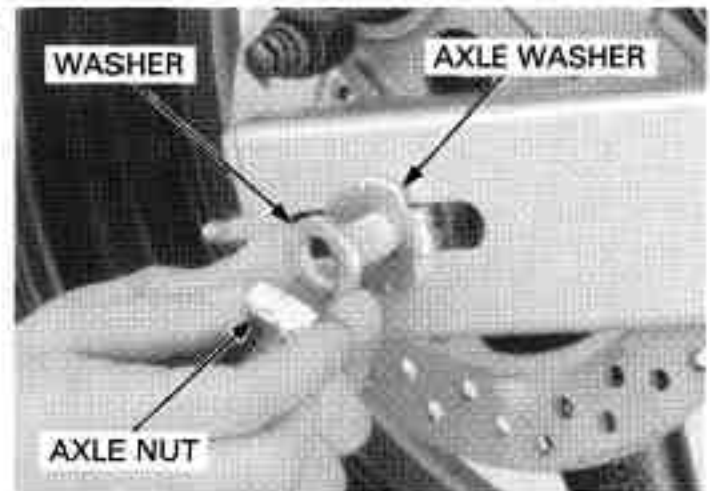

Derail the drive chain from the driven sprocket

Remove the rear axle, then remove the rear wheel.

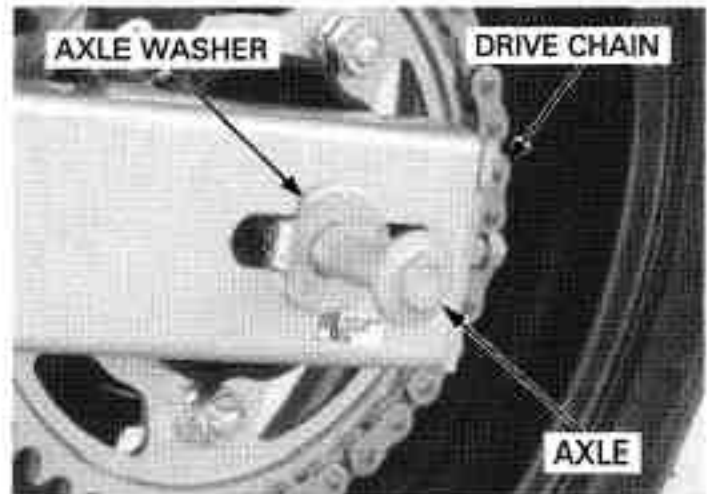

Do not operate the brake pedal after the rear wheel is removed.

Remove the side collars.

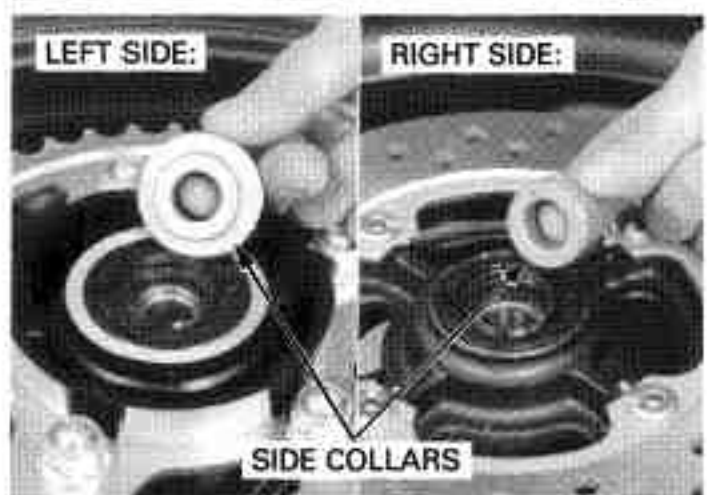

INSPECTION

Axle

Place the axle in V-blocks and measure the runout. Actual runout is 1/2 the total indicator reading.

SERVICE LIMIT: 0.2 mm (0.01 in)

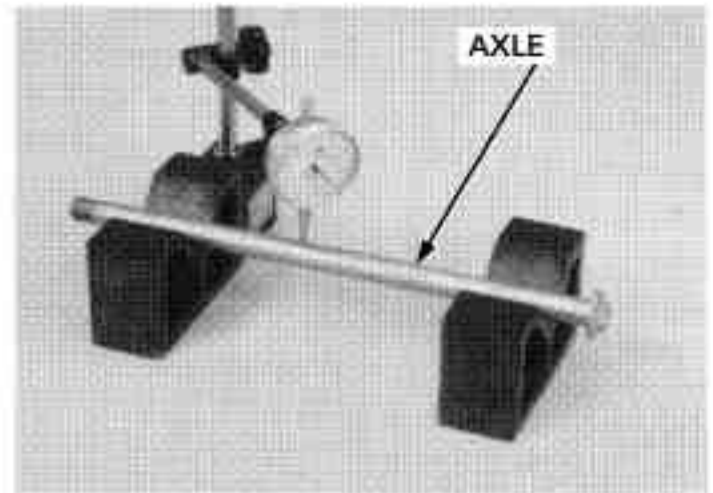

Wheel bearing

Turn the inner race of each bearing with your finger. Bearings should turn smoothly and quietly. Also check that the bearing outer race fits tightly in the hub.

Replace the wheel bearings in pairs.

Remove and discard the bearings if the races do not turn smoothly and quietly, or if they fit loosely in the hub.

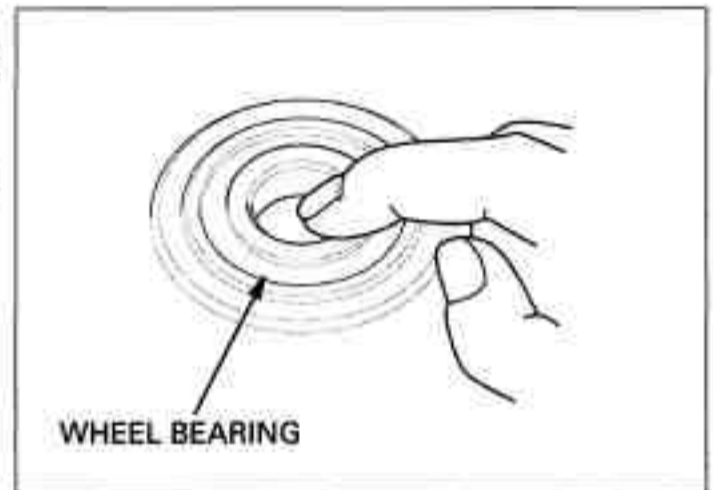

Wheel rim runout

Check the rim runout by placing the wheel in a turning stand. Spin the wheel slowly and read the runout using a dial indicator. Actual runout is 1/2 the total indicator reading.

SERVICE LIMITS:

Radial: 2.0 mm (0.08 in)

Axial: 2.0 mm (0.08 in)

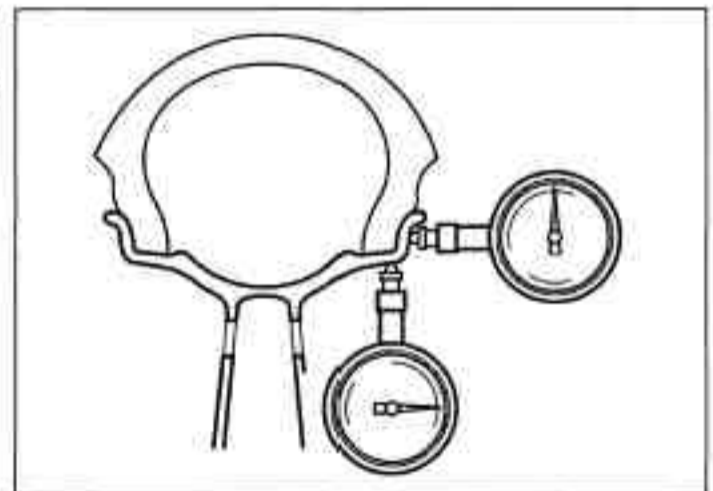

Driven sprocket

Check the condition of the final driven sprocket teeth. Replace the sprocket if worn or damaged.

- If the final driven sprocket requires replacement, inspect the drive chain and drive sprocket.
- Never install a new drive chain on a worn sprocket or a worn chain on new sprockets. Both chain and sprocket must be in good condition or the replacement chain or sprocket will wear rapidly.

Wheel balance

Refer to the wheel balance servicing (page 14-17).

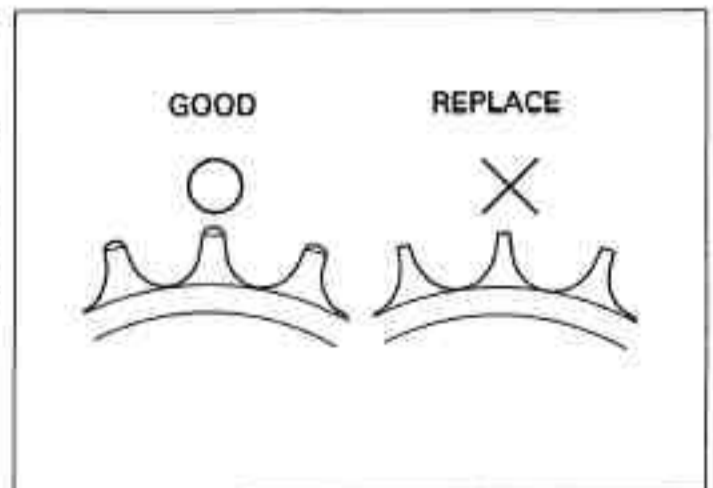

REAR WHEEL/SUSPENSION

DISASSEMBLY

Remove the bolts and brake disc.
Remove the right dust seal.

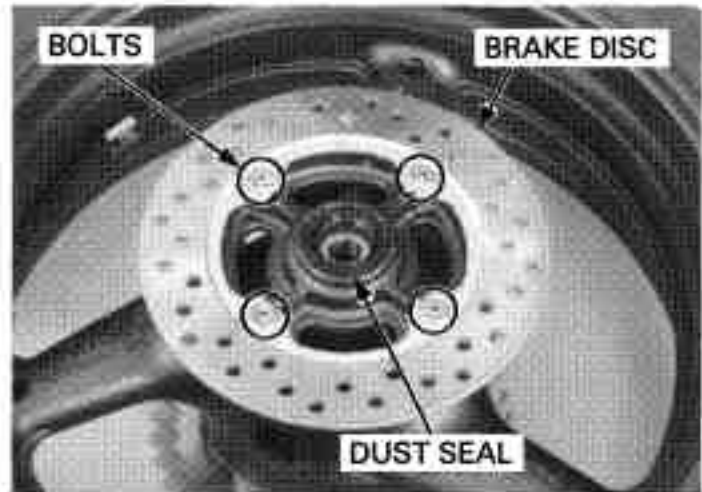

If you will be disassemble the driven flange, loosen the driven sprocket nuts before removing the driven flange from the wheel hub.

Remove the left dust seal.

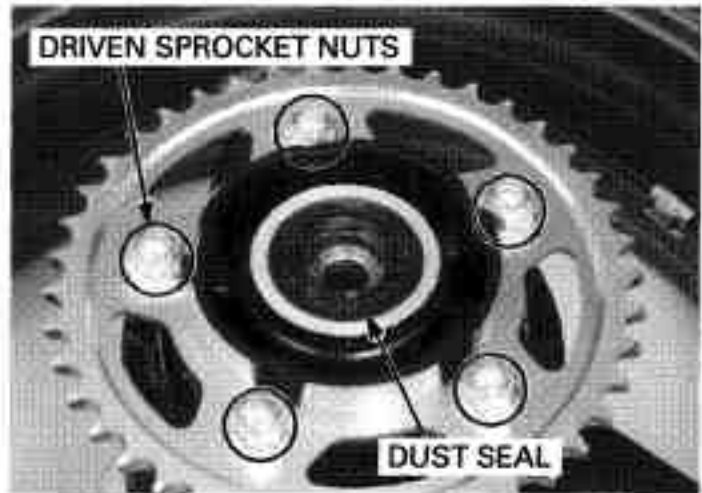

Remove the driven flange assembly from the left wheel hub.

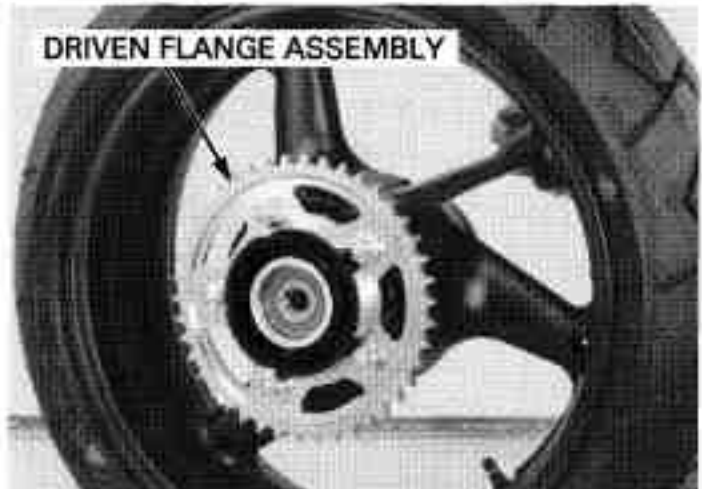

Remove the wheel damper rubbers.
Remove the O-ring.

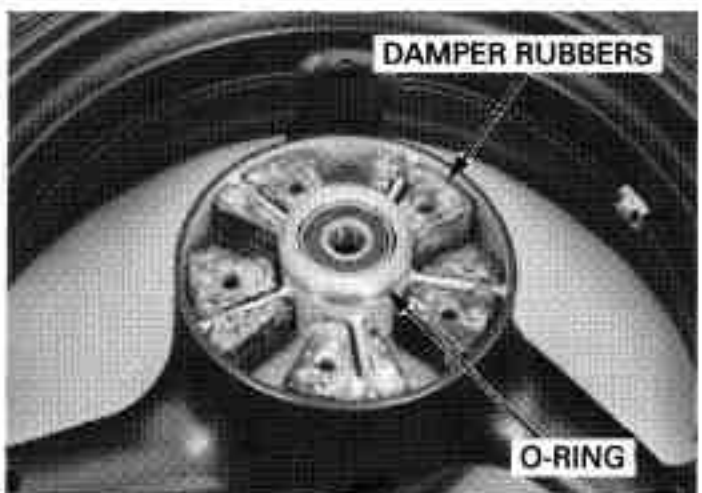

Driven flange bearing removal

Remove the driven flange collar.
Drive out the driven flange bearing.

DRIVEN FLANGE COLLAR

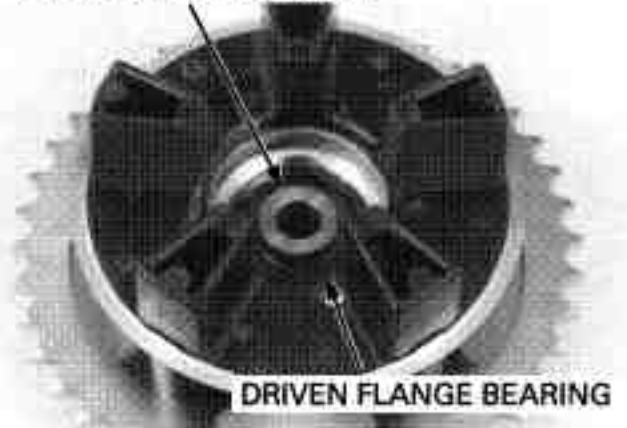

Wheel bearing removal

Install the bearing remover head into the bearing.
From the opposite side install the bearing remover shaft and drive the bearing out of the wheel hub.
Remove the distance collar and drive out the other bearing.

TOOLS:

Bearing remover head, 17 mm 07746-0050500
Bearing remover shaft 07GGD-0010100 or 07746-0050100

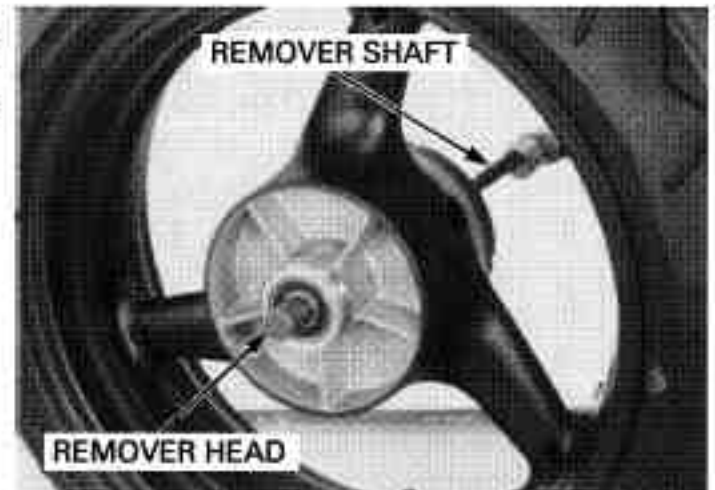

ASSEMBLY

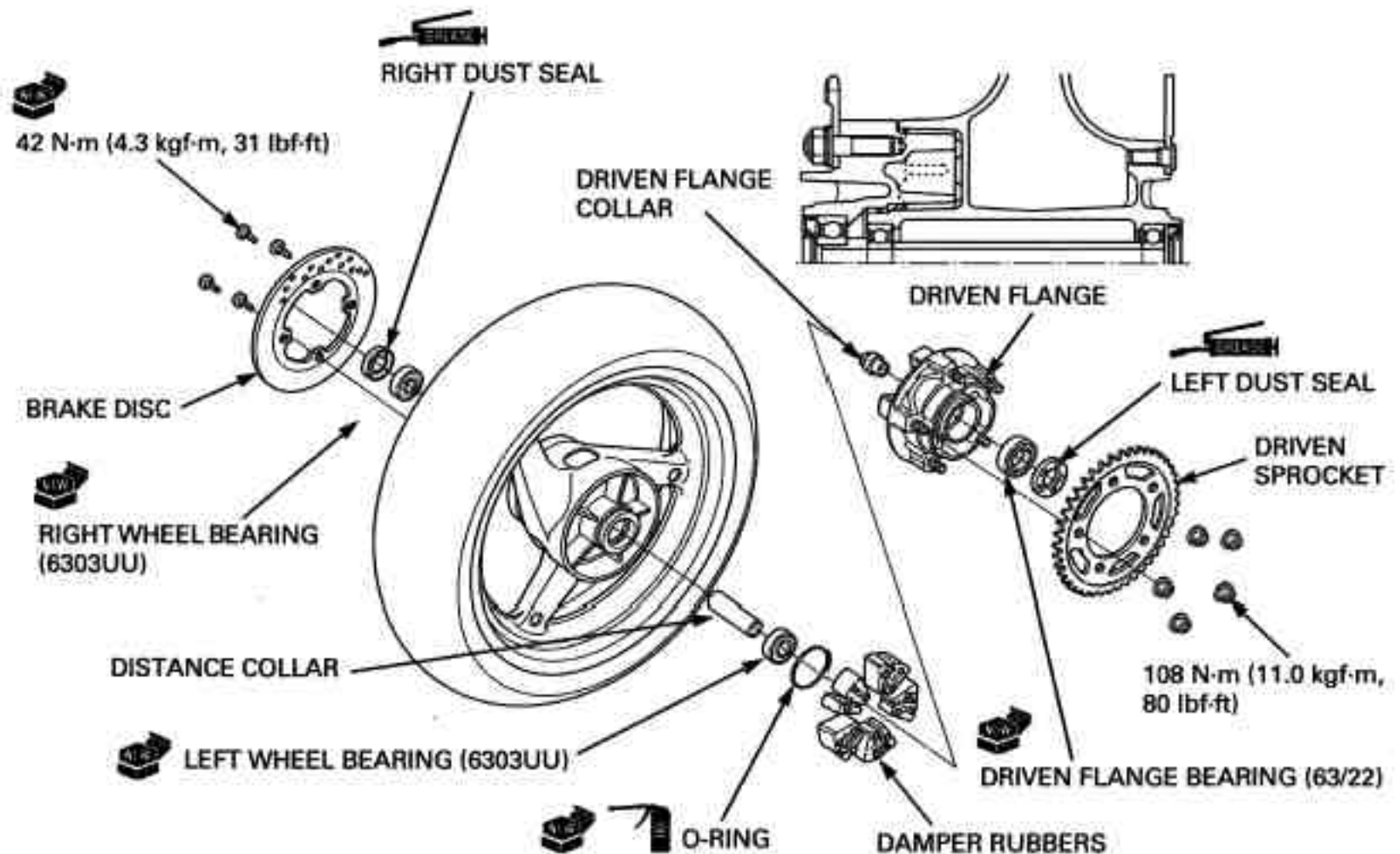

REAR WHEEL/SUSPENSION

Never install the old bearings, once the bearings has been removed, the bearing must be replaced with new ones.

Wheel bearing installation

Drive in a new right bearing squarely.

TOOLS:

Driver 07749-0010000
Attachment, 42 X 47 mm 07746-0010300
Pilot, 17 mm 07746-0040400

Install the distance collar

Drive in the left side bearing using the same tools.

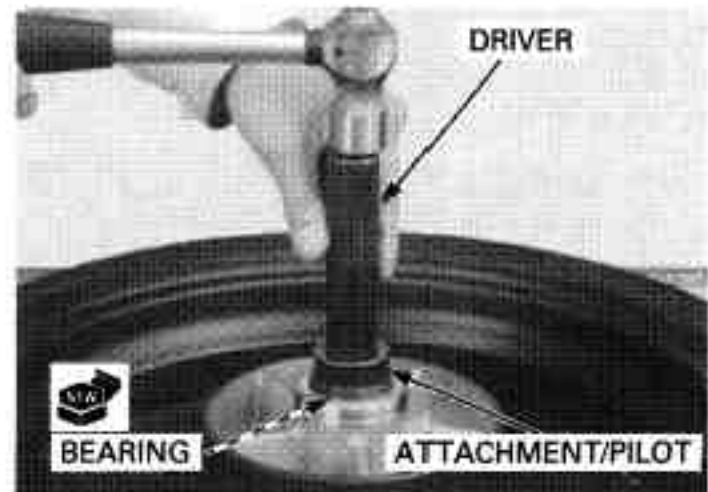

Driven flange bearing installation

Place a new bearing onto the suitable base with its marking facing down.
Drive the driven flange collar in a new driven flange bearing until it is fully seated.

TOOLS:

Driver 07749-0010000
Attachment, 28 X 30 mm 07946-1870100
Pilot, 17 mm 07746-0040400

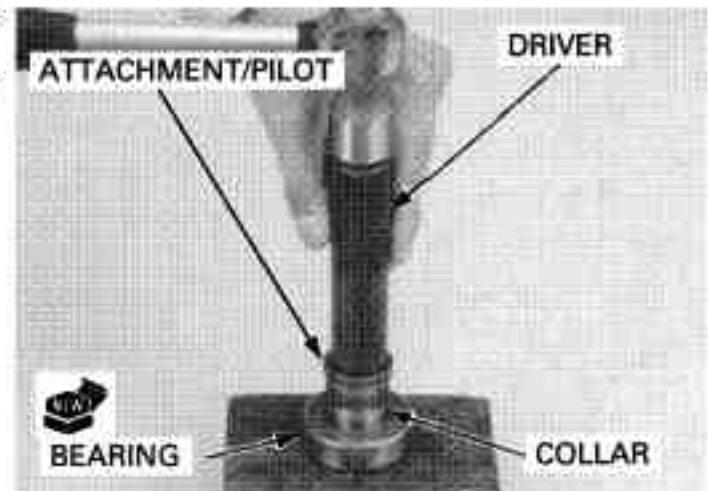

Drive the driven flange bearing into the driven flange using the special tools.

TOOLS:

Driver 07749-0010000
Attachment, 52 X 55 mm 07746-0010400
Pilot, 17 mm 07746-0040400

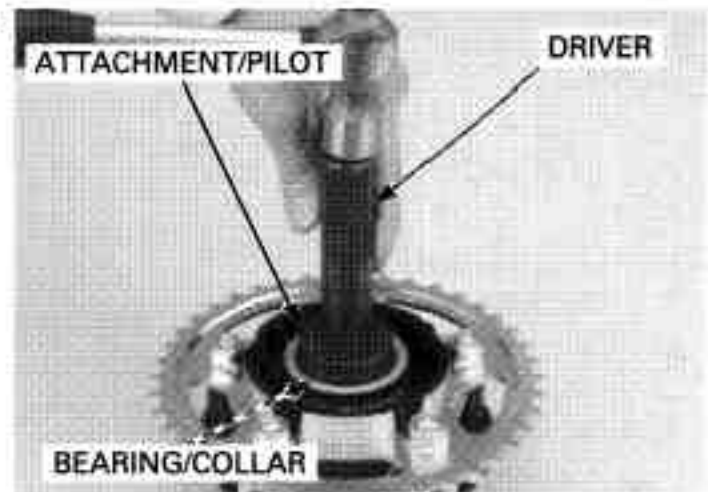

Replace the damper rubbers as a set.

Install the wheel damper rubbers into the wheel hub.

Apply grease to a new O-ring and install it into the groove of the wheel hub.

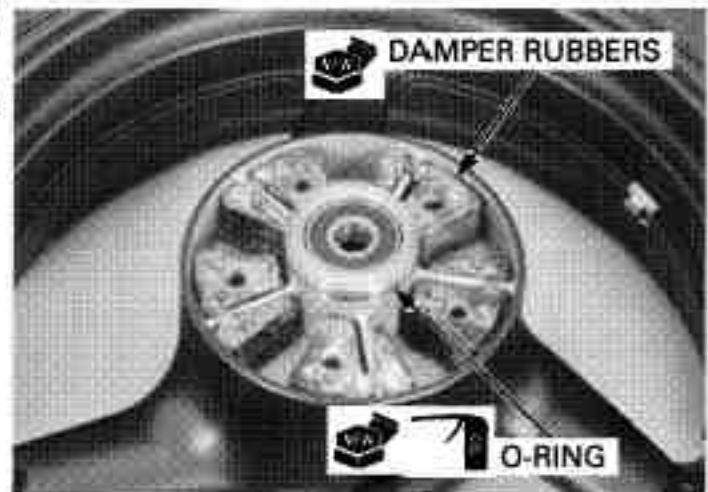

Apply grease to the driven flange and rear wheel hub contact area.
Install the driven flange assembly into the left wheel hub.

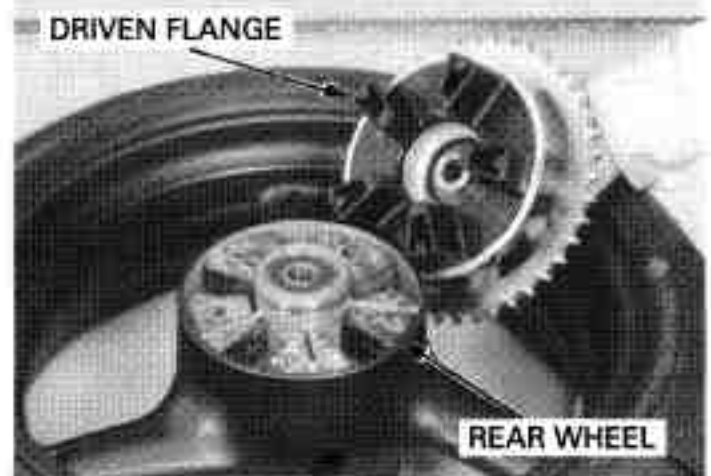

If the driven sprocket was removed, install the driven sprocket and tighten the nuts.

TORQUE: 108 N·m (11.0 kgf·m, 80 lbf·ft)

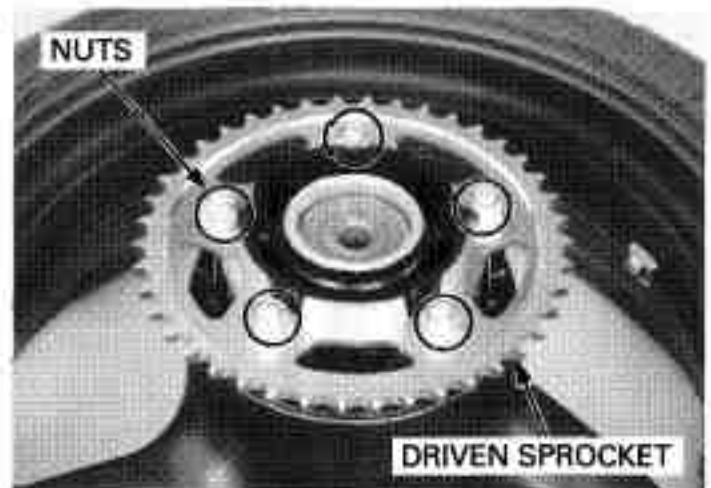

Apply grease to the dust seal lips, then install it into the driven flange.



Install the brake disc with its rotating direction mark facing out.
Install and tighten new bolts to the specified torque.

TORQUE: 42 N·m (4.3 kgf·m, 31 lbf·ft)

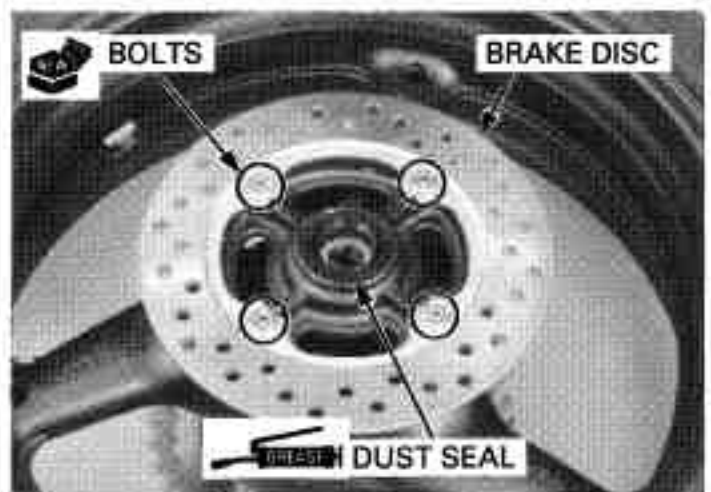

REAR WHEEL/SUSPENSION

INSTALLATION

Apply grease to the side collar inside and grooves.
Install the side collars.

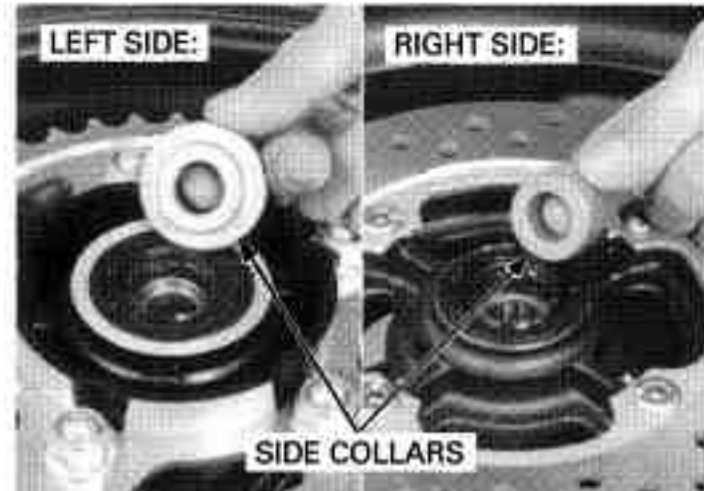

Install the rear brake caliper bracket onto the guide of the swingarm.

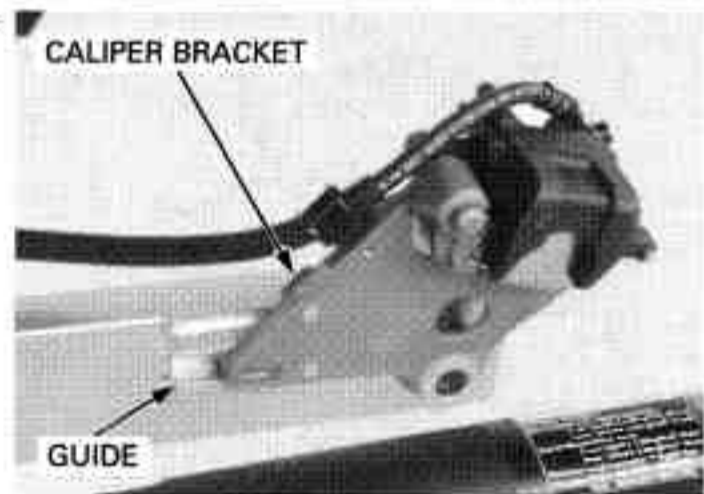

Be careful not to damage the brake pads.

Place the rear wheel into the swingarm carefully aligning the brake disc between the brake pads. Install the drive chain over the driven sprocket. Install the rear axle washer and rear axle from the left side.

Make sure the "F" mark on the rear axle washer facing forward.

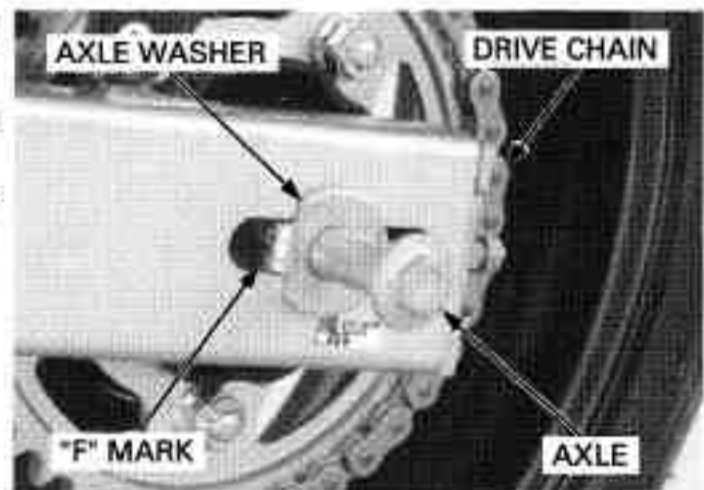

Install the axle washer with its "F" mark facing forward.
Install the washer and axle nut.

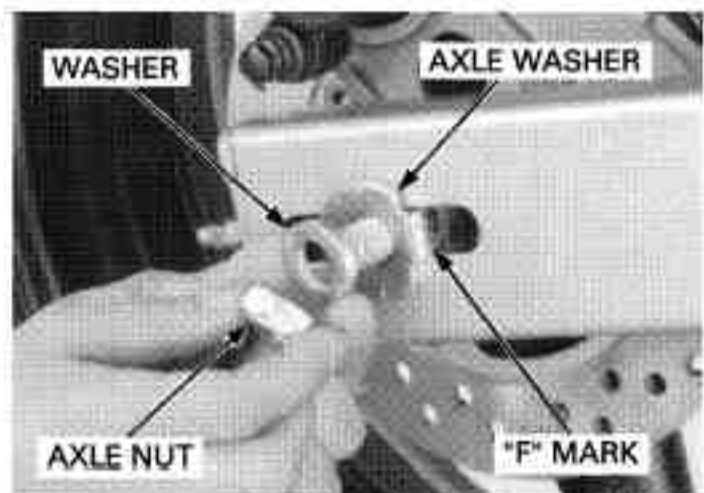

Adjust the drive chain slack (page 4-23).
Tighten the axle nut to the specified torque.
TORQUE: 88 N·m (9.0 kgf·m, 65 lbf·ft)

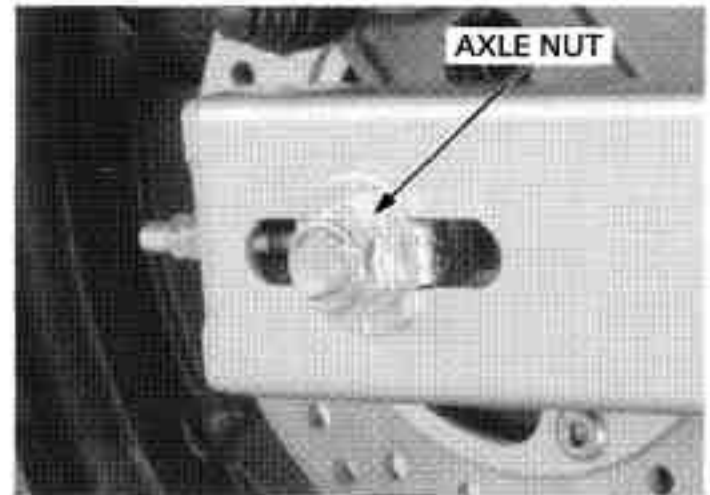

SHOCK ABSORBER

REMOVAL

Support the motorcycle using a safety stand or a hoist, raise the rear wheel off the ground.

Remove the side cover (page 3-4).
Remove the rear wheel (page 15-6).
Remove the regulator/rectifier (page 17-9).

Remove the shock absorber lower mounting bolt/nut.



Remove the shock absorber upper mounting bolt/nut and the shock absorber.



INSPECTION

Visually inspect the damper unit for damage.

Check for the:

- Damper rod for bend or damage
- Damper unit for deformation or oil leaks
- Upper mounting bushing for wear or damage

Inspect all the other parts for wear or damage.



REAR WHEEL/SUSPENSION

SHOCK ABSORBER DISPOSAL PROCEDURE

Center punch the damper case to mark the drilling point.

Wrap the shock absorber inside a plastic bag. Support the shock absorber upright in a vise as shown.

Through the open end of the bag, insert a drill motor with a sharp 2 - 3 mm (5/64 - 1/8 in) drill bit.

Point the valve away from you to prevent debris getting in your eyes.

Hold the bag around the drill motor and briefly run the drill motor inside the bag; this will inflate the bag with air from the motor and help keep the bag from getting caught in the bit when you start.

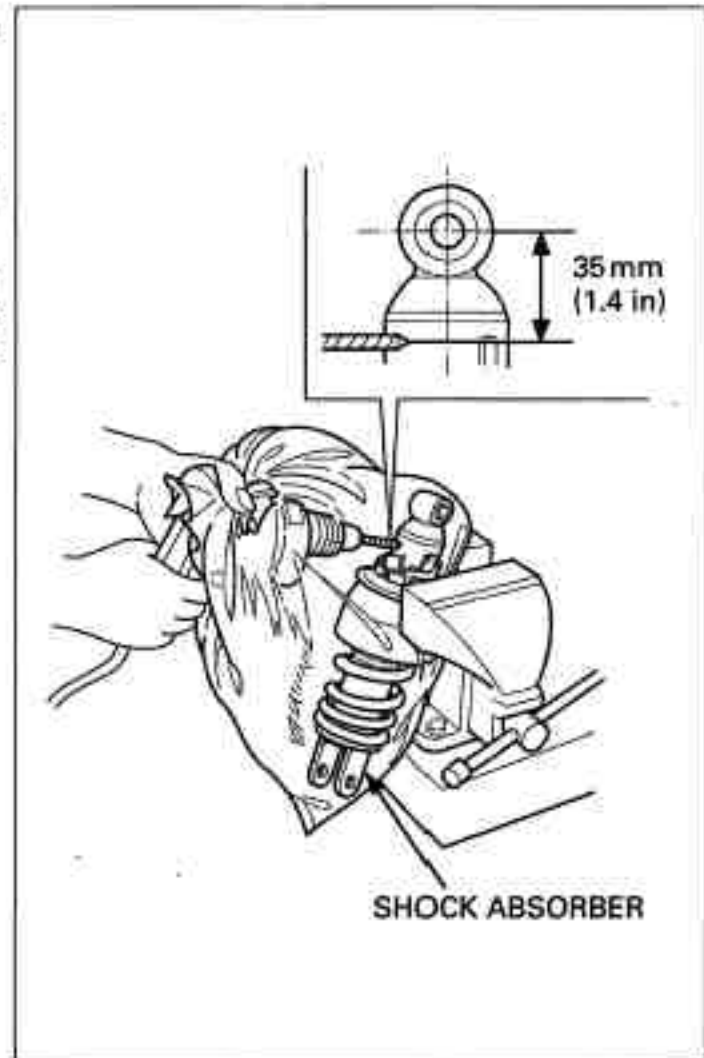

INSTALLATION

Install the shock absorber into the frame. Install the upper and lower mounting bolt/nut. Tighten the upper mounting nut to the specified torque.

TORQUE: 37 N·m (3.8 kgf·m, 27 lbf·ft)



Tighten the lower mounting nut to the specified torque.

TORQUE: 37 N·m (3.8 kgf·m, 27 lbf·ft)

Install the removed parts in the reverse order of removal.



SWINGARM

REMOVAL

Support the motorcycle using a safety stand or a hoist, raise the rear wheel off the ground.

Remove the rear wheel (page 15-6)

Remove the bolt, then remove the gearshift pedal link from the spindle.

Remove the socket bolts and left footpeg holder.

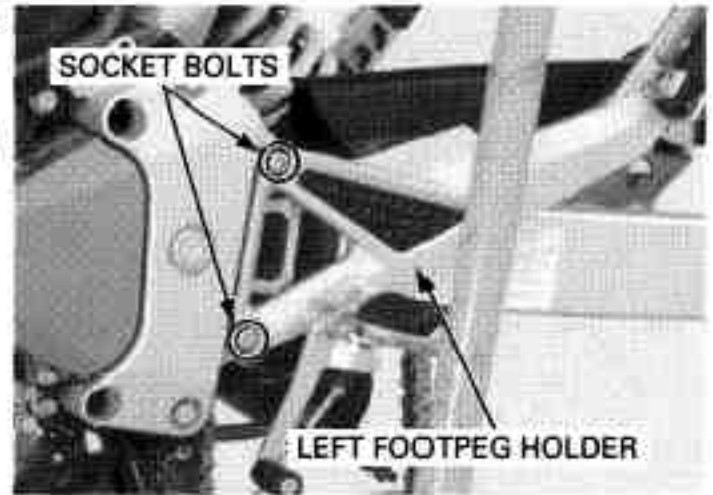

Remove the brake hose clamp bolts.

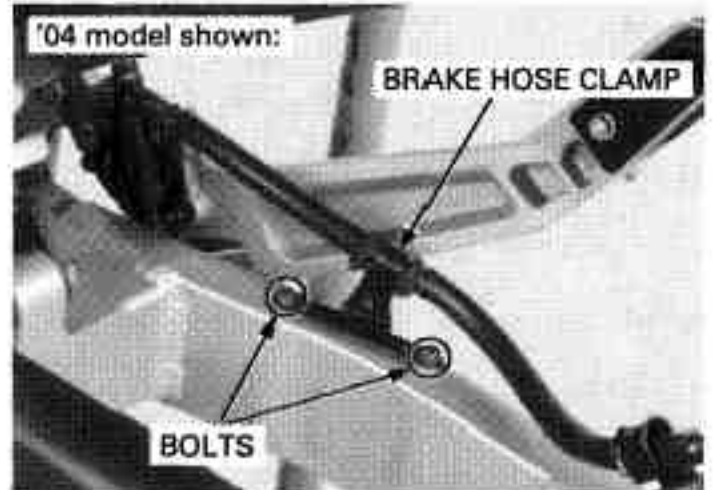

Remove the shock absorber lower mounting bolt/nut.

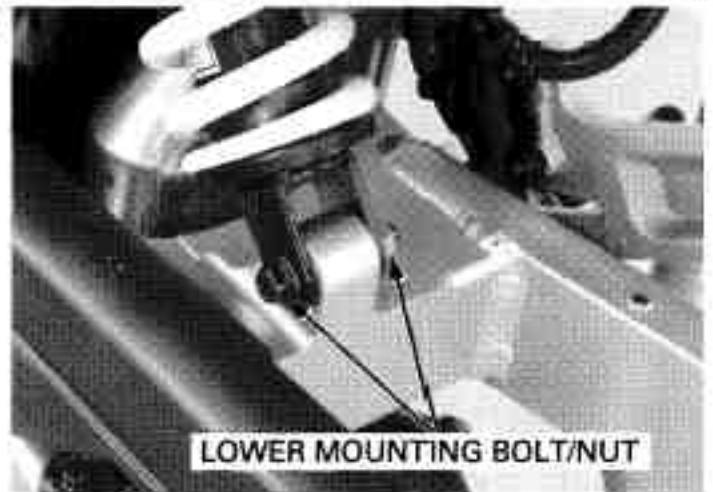

Remove the bolts and drive chain case.

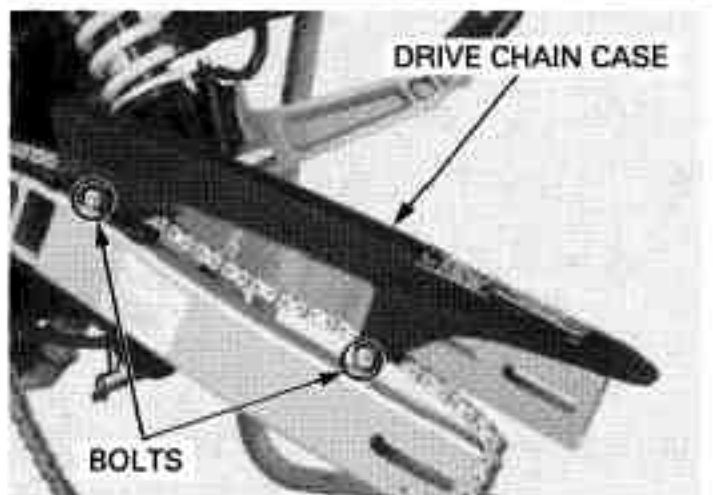

REAR WHEEL/SUSPENSION

Remove the swingarm pivot nut.

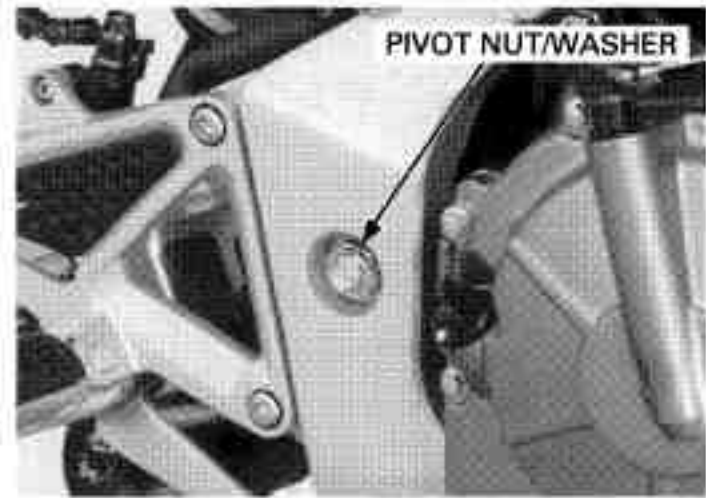

Loosen the left pivot bracket bolts.
Slightly pull the pivot bracket outward.
Remove the swingarm pivot bolt and swingarm.

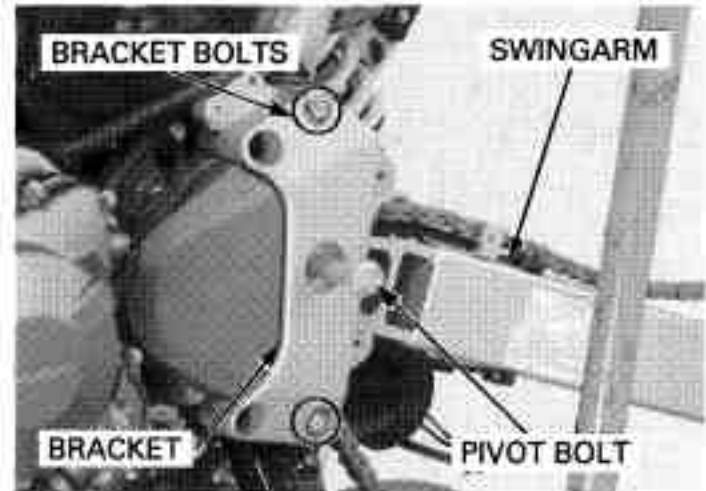

DISASSEMBLY/INSPECTION

Remove the bolts and drive chain slider.
Check the drive chain slider for wear or damage.
Replace if necessary.

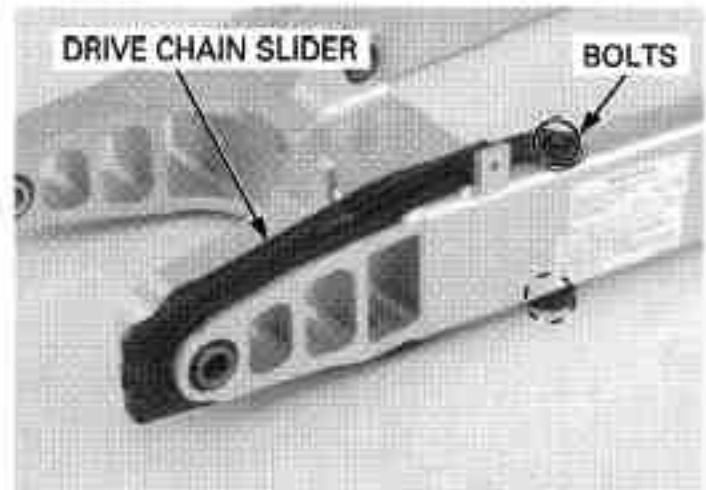

Remove the pivot collar and dust seals from the swingarm left pivot.

Check the dust seals and collar for damage or fatigue.

Check the needle bearings for damage.

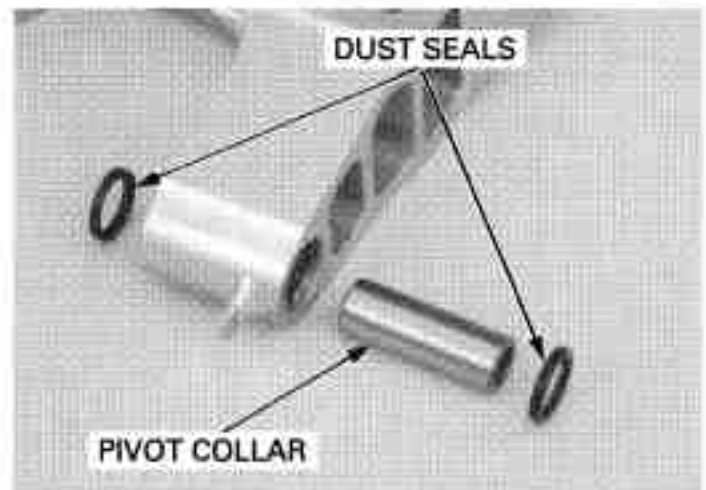

Remove the pivot side collars and dust seals from the swingarm right pivot.

Check the dust seals and collars for damage or fatigue.

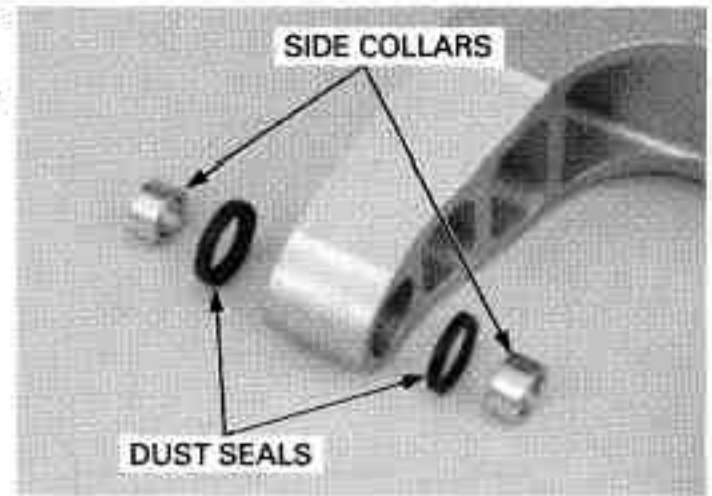

Turn the inner race of right pivot bearings with your finger.

The bearings should turn smoothly and quietly. Also check that the bearing outer race fits tightly in the hub.

Remove and discard the bearings if the races do not turn smoothly and quietly, or if they fit loosely in the pivot.

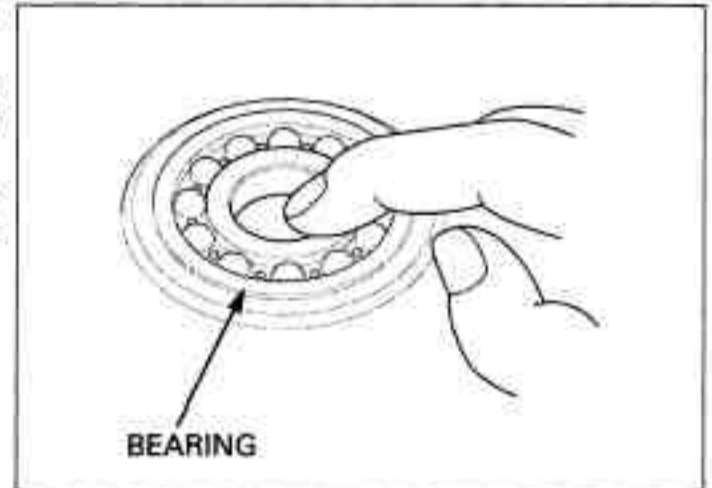

Remove the pivot collar and dust seals from the swingarm shock absorber pivot.

Check the dust seals and collar for damage or fatigue.

Check the needle bearing for damage.

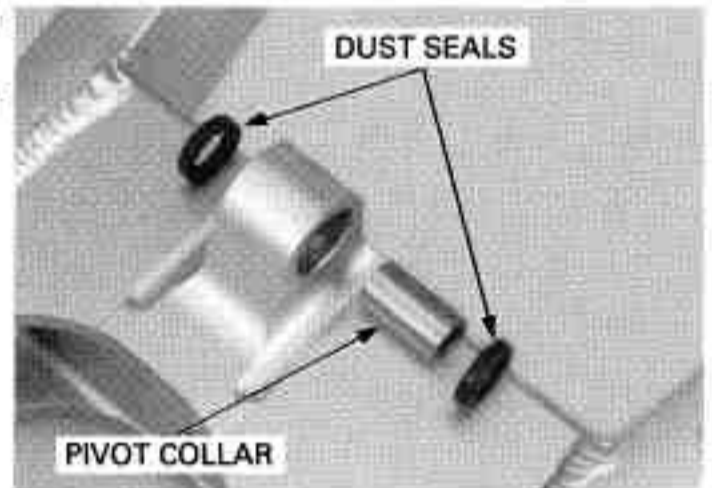

PIVOT BEARING REPLACEMENT

Remove the snap ring.

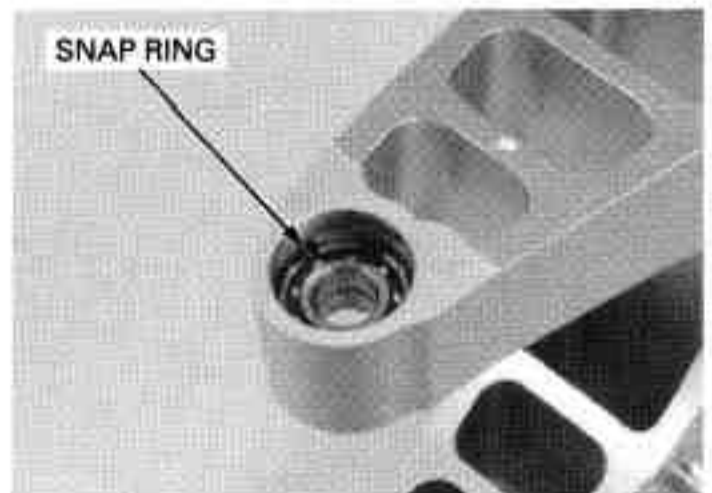

REAR WHEEL/SUSPENSION

Press the right pivot radial ball bearings out using the special tool and a hydraulic press.

TOOL:

Driver shaft 07946-MJ00100

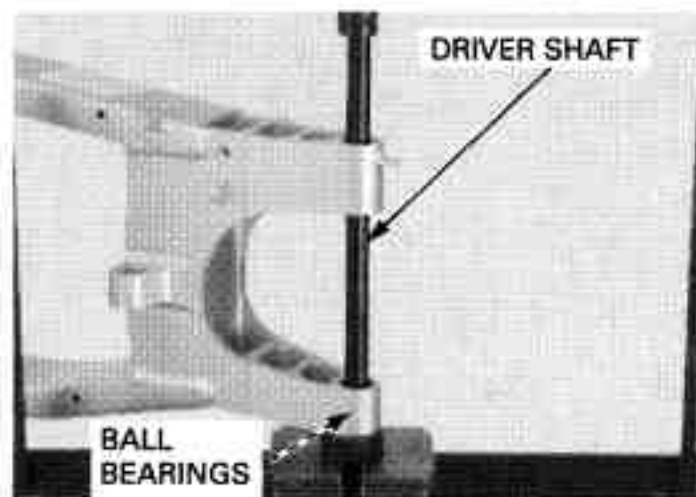

Press the left pivot needle bearings out using the special tools and a hydraulic press.

TOOLS:

Driver 07749-0010000

Attachment, 24 X 26 mm 07746-0010700

Pilot, 22 mm 07746-0041000

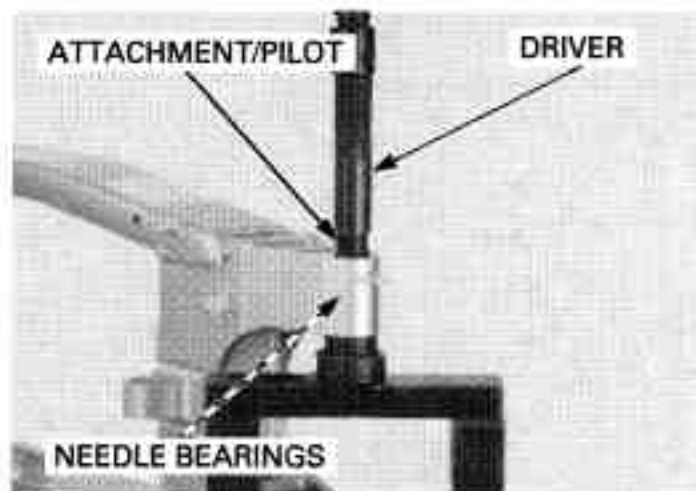

Pack new needle bearings with grease.
Press the inner needle bearing into the swingarm left pivot until the depth from the swingarm outer surface is 28 - 29 mm (1.10 - 1.14 in) using the special tools and a hydraulic press.

TOOLS:

Driver 07749-0010000

Attachment, 24 X 26 mm 07746-0010700

Pilot, 22 mm 07746-0041000

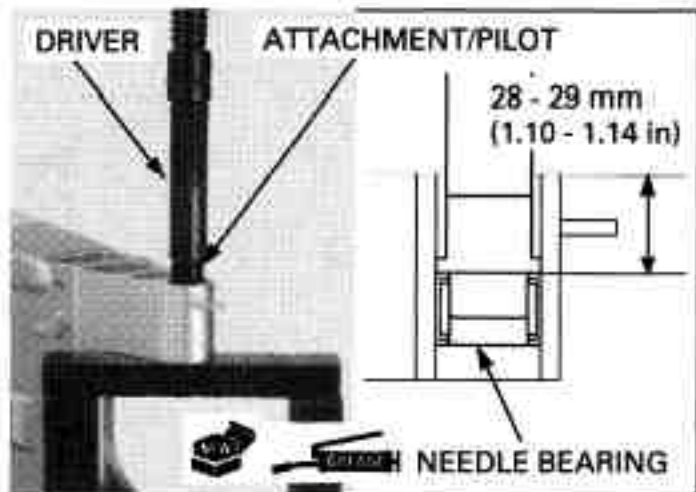

Press the inner needle bearing into the swingarm left pivot until the depth from the swingarm outer surface is 4 - 5 mm (0.16 - 0.20 in) using the special tools and a hydraulic press.

TOOLS:

Driver 07749-0010000

Attachment, 24 X 26 mm 07746-0010700

Pilot, 22 mm 07746-0041000

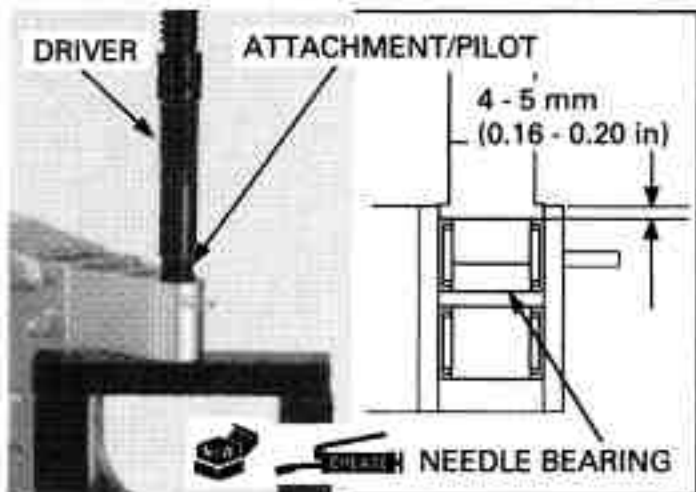

Press the radial ball bearings in using the special tools and a hydraulic press.

TOOLS:

Driver 07749-0010000
Attachment, 32 X 35 mm 07746-0010100
Pilot, 15 mm 07746-0040300

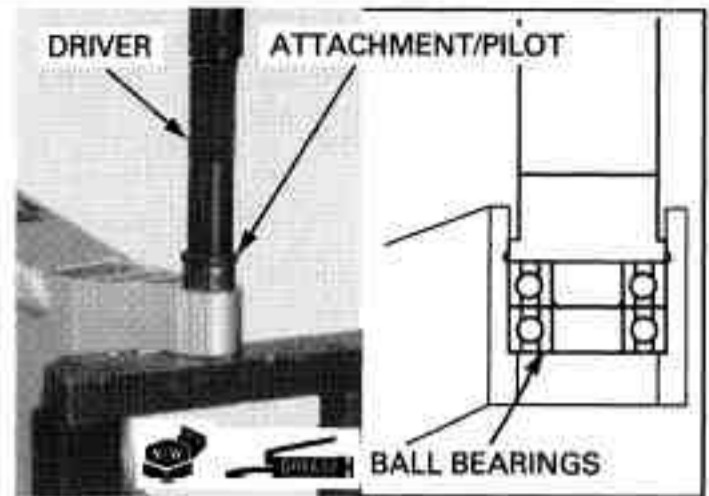

Install the snap ring into the groove securely.

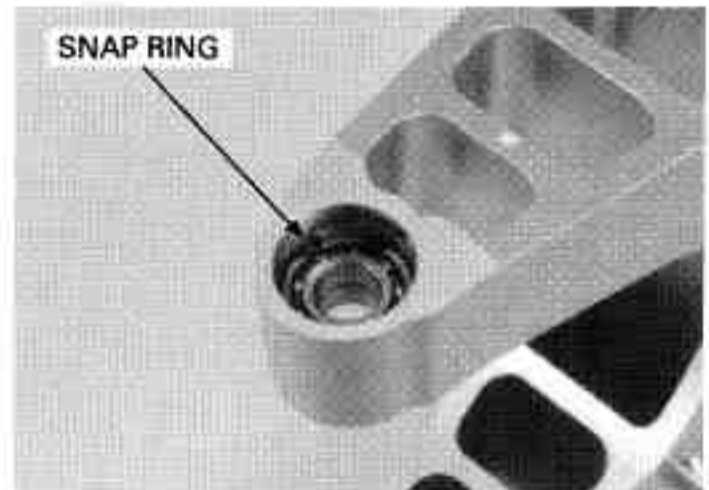

Shock absorber bearing replacement

Remove the needle bearing out of swingarm using the special tool.

TOOL:

Needle bearing remover 07LMC-KV30100

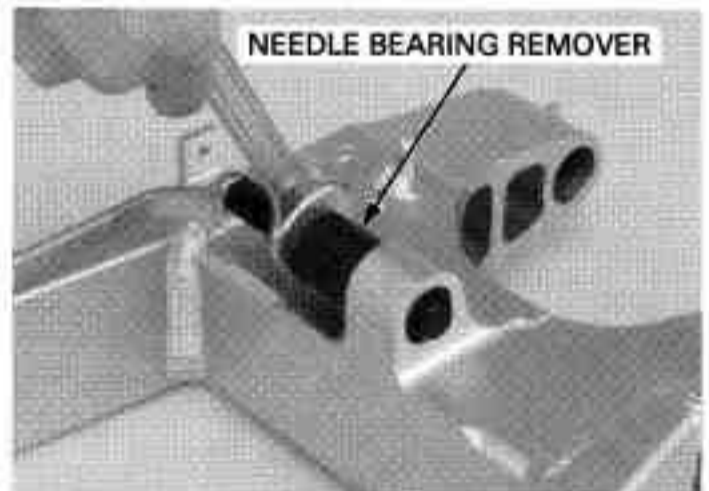

Apply grease to the needle rollers of the new bearing.

Install the needle bearing into the pivot until the depth from the swingarm outer surface is 5.2 – 5.7 mm (0.20 – 0.22 in), using the same tool.

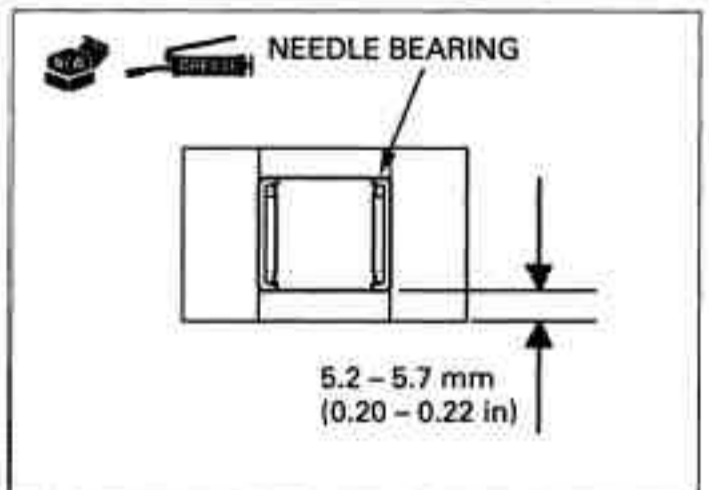

REAR WHEEL/SUSPENSION

ASSEMBLY

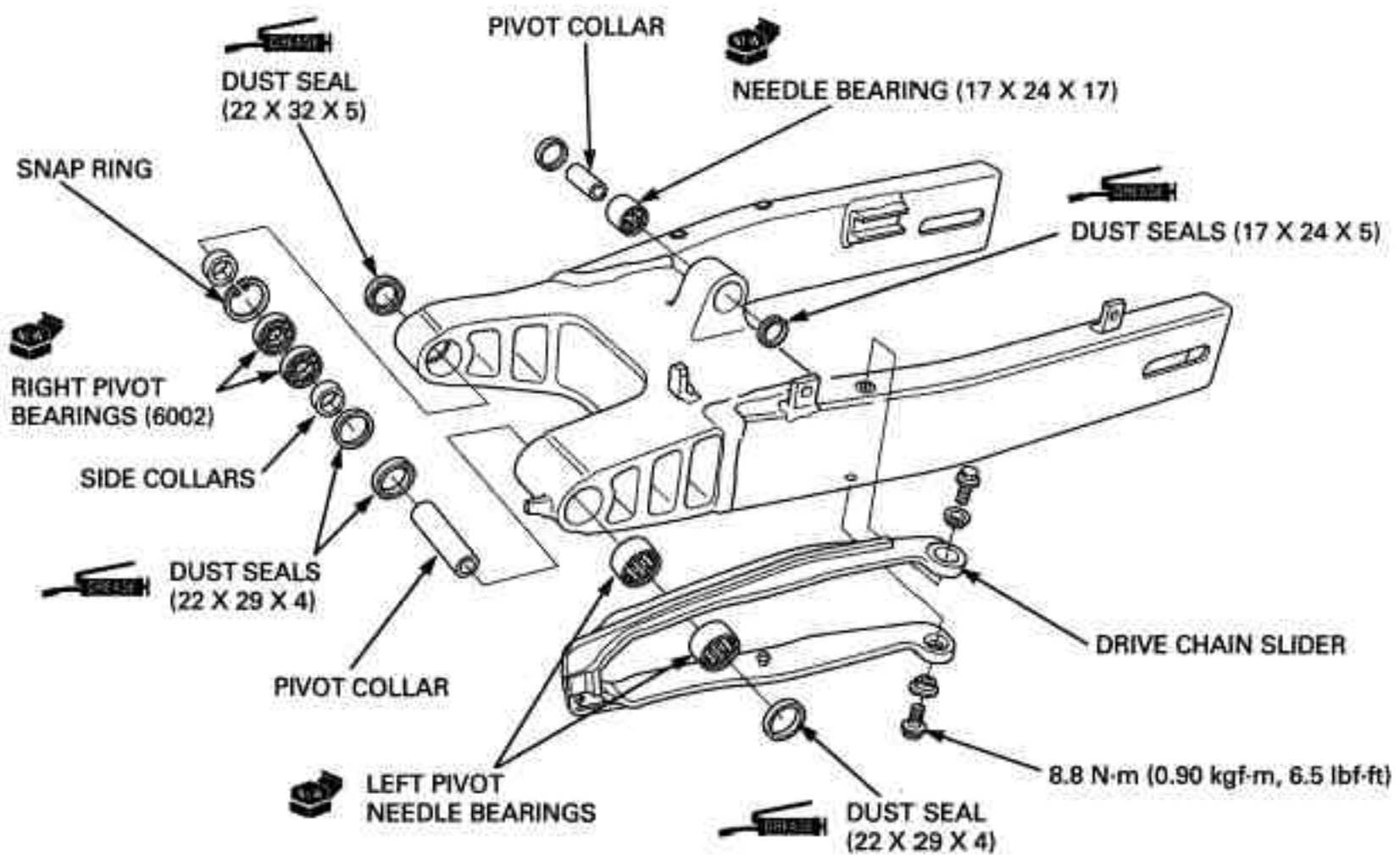

Apply grease to the dust seal lips, then install the dust seals and pivot collar into the swingarm shock absorber pivot.

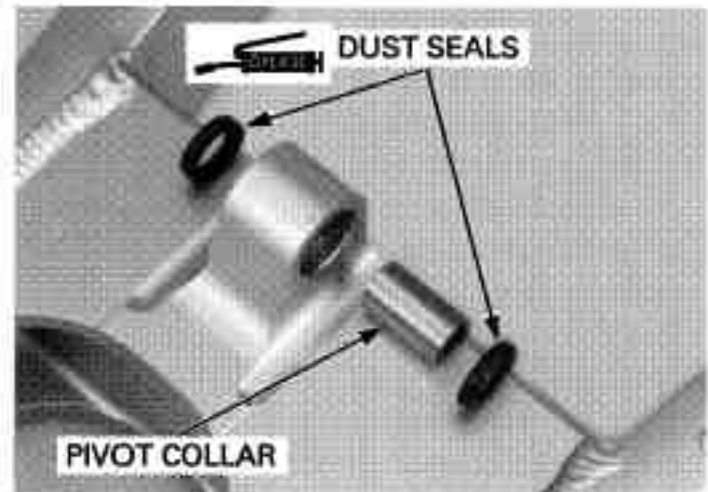

Apply grease to the dust seal lips, then install the dust seals into the right swingarm pivot. Fill the grease up between the inner dust seal and needle bearing. Install the pivot side collars.

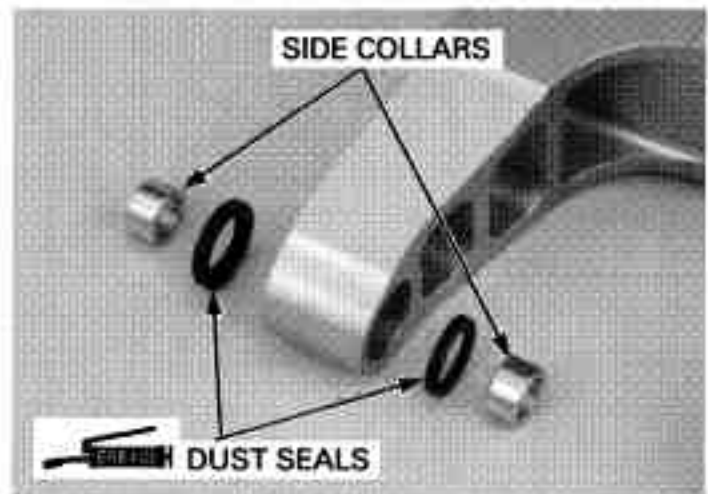

Apply grease to the dust seal lips, then install the dust seals and pivot collar into the left swingarm pivot.

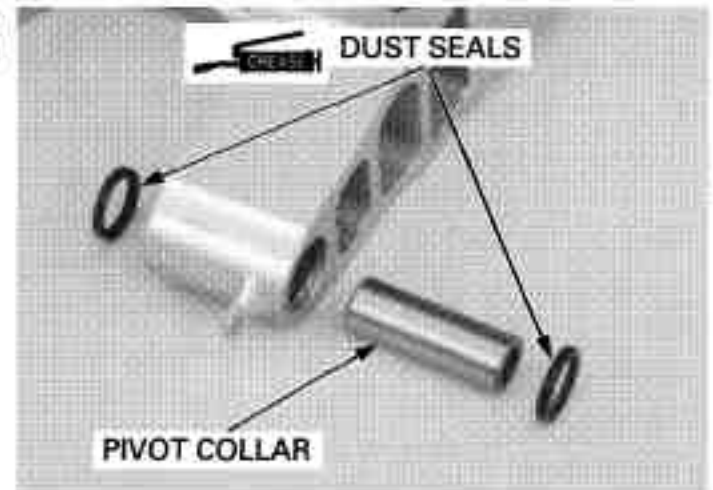

Install the drive chain slider aligning the slit with the boss on the swingarm.
Install the drive chain slider bosses into the holes in the swingarm.

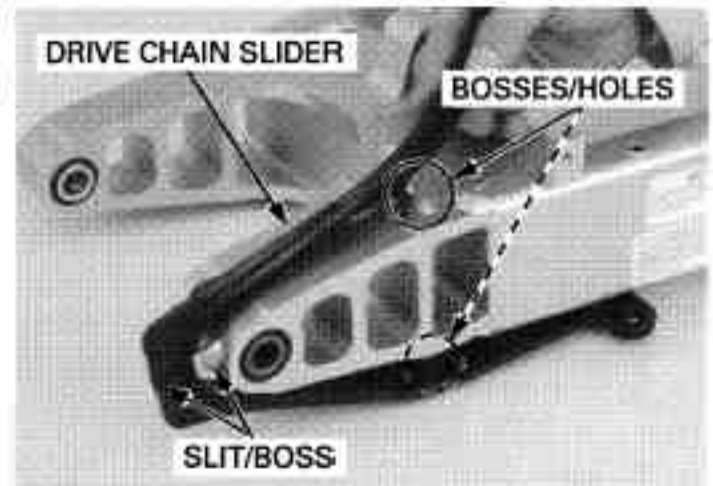

Install and tighten the drive chain slider bolts to the specified torque.

TORQUE: 8.8 N·m (0.90 kgf·m, 6.5 lbf·ft)

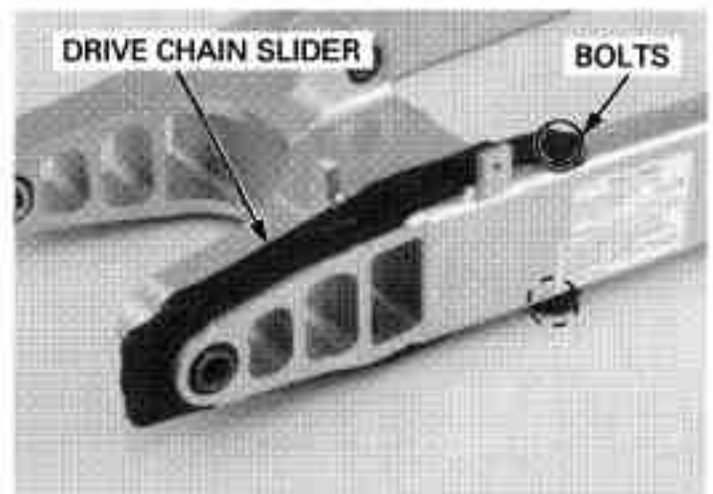

INSTALLATION

Apply thin coat of grease to the swingarm pivot bolt surface.

Install the swingarm into the frame.

Tighten the left pivot bracket bolts securely.

Install the swingarm pivot bolt from the left side.

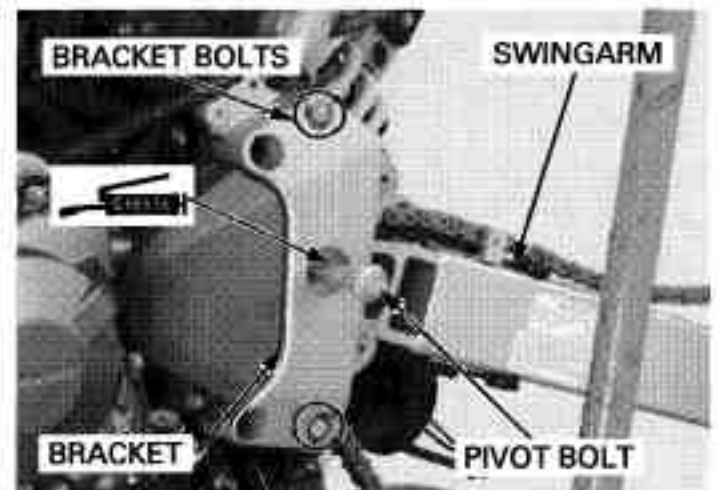

REAR WHEEL/SUSPENSION

Install and tighten the swingarm pivot nut to the specified torque.

TORQUE: 88 N-m (9.0 kgf-m, 65 lbf-ft)

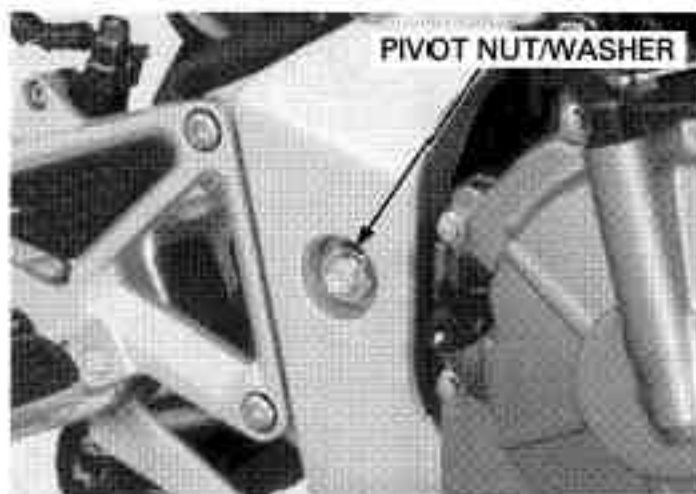

Install the drive chain case aligning its slit with the boss on the swingarm.

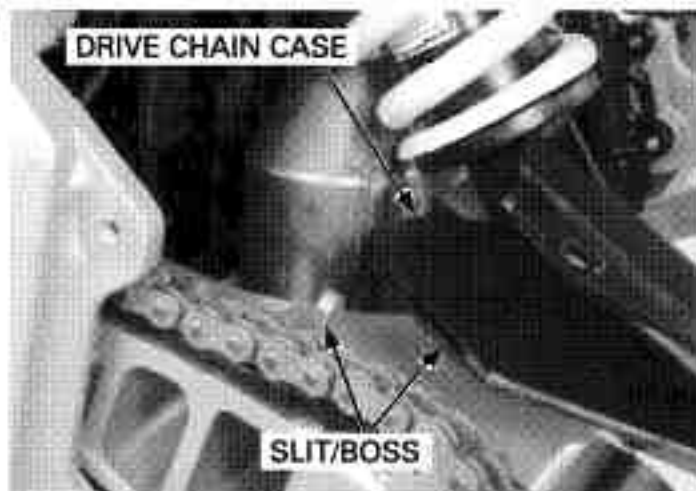

Tighten the drive chain case bolts to the specified torque.

TORQUE: 12 N-m (1.2 kgf-m, 9 lbf-ft)

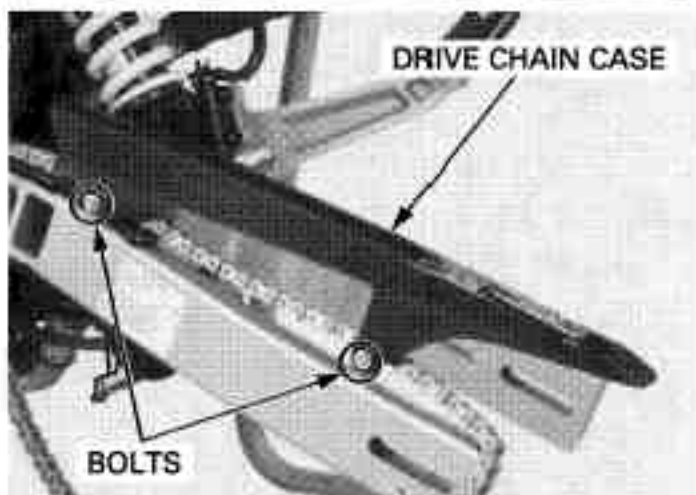

Install the shock absorber lower mounting bolt/nut, then tighten the nut to the specified torque.

TORQUE: 37 N-m (3.8 kgf-m, 27 lbf-ft)

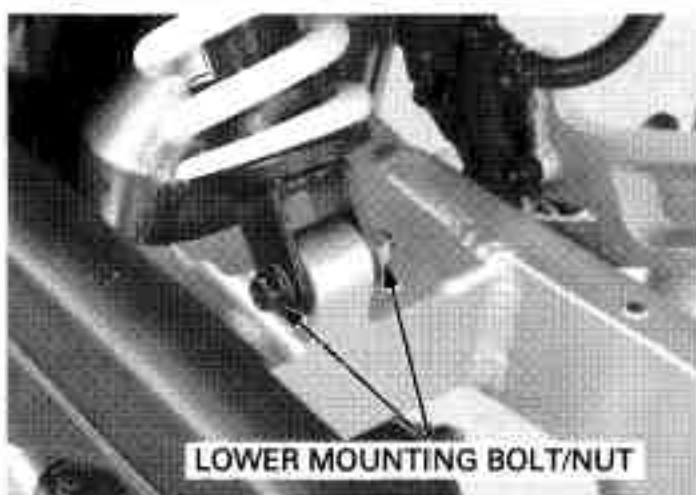

Route the brake hose properly, then install the rear brake caliper/bracket onto the boss of the swing-arm.

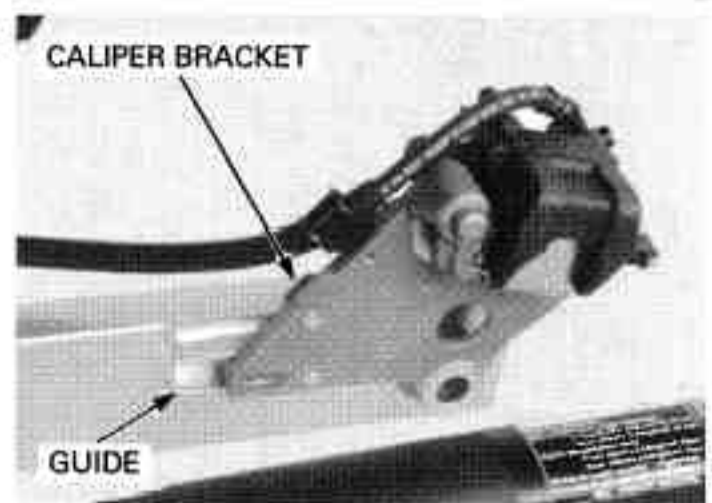

Install and tighten the brake hose clamp bolts securely.

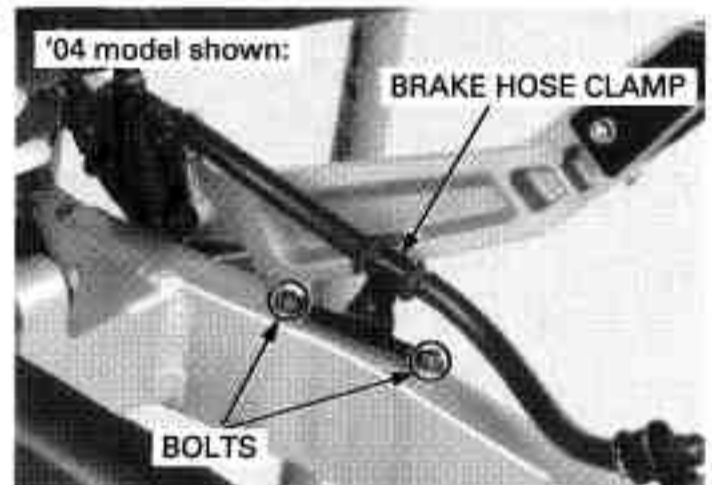

Install the left footpeg holder and tighten the bolts to the specified torque.

TORQUE: 26 N·m (2.7 kgf·m, 20 lbf·ft)

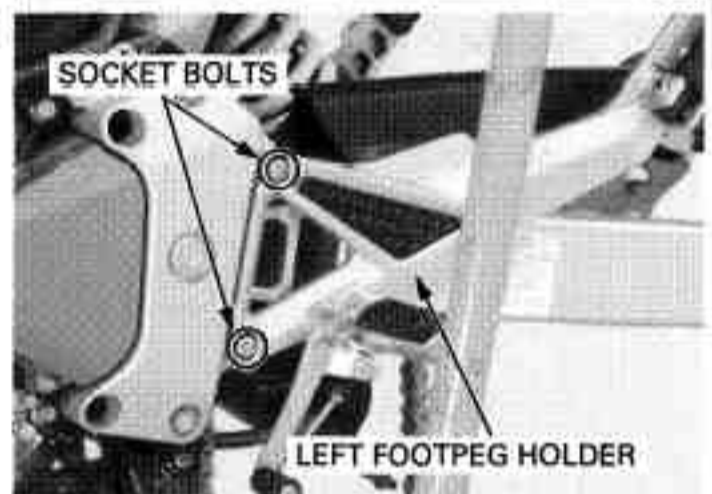

Install the gearshift pedal link to the spindle aligning its slit with the punch mark on the spindle. Tighten the bolt to the specified torque.

TORQUE: 20 N·m (2.0 kgf·m, 14 lbf·ft)

Install the rear wheel (page 15-12).

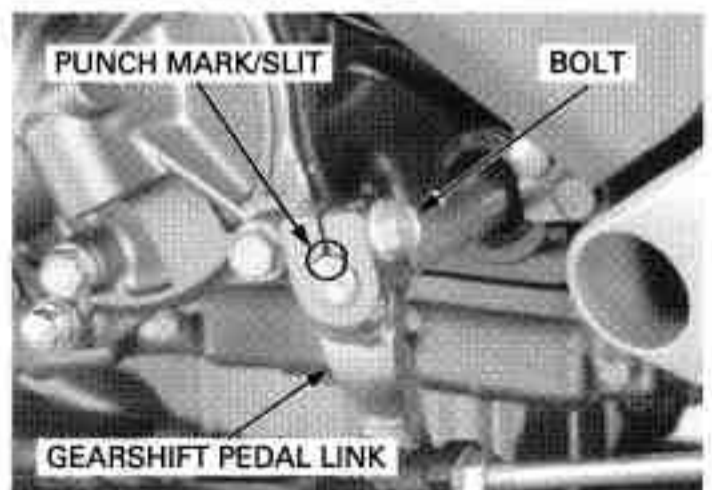

16. HYDRAULIC BRAKE

COMPONENT LOCATION	16-2	FRONT MASTER CYLINDER	16-12
SERVICE INFORMATION	16-4	REAR MASTER CYLINDER	16-18
TROUBLESHOOTING	16-5	FRONT BRAKE CALIPER	16-24
BRAKE FLUID REPLACEMENT/ AIR BLEEDING	16-6	REAR BRAKE CALIPER	16-28
BRAKE PAD/DISC	16-9	BRAKE PEDAL	16-32

HYDRAULIC BRAKE

COMPONENT LOCATION

FRONT:

12 N·m (1.2 kgf·m, 9 lbf·ft)

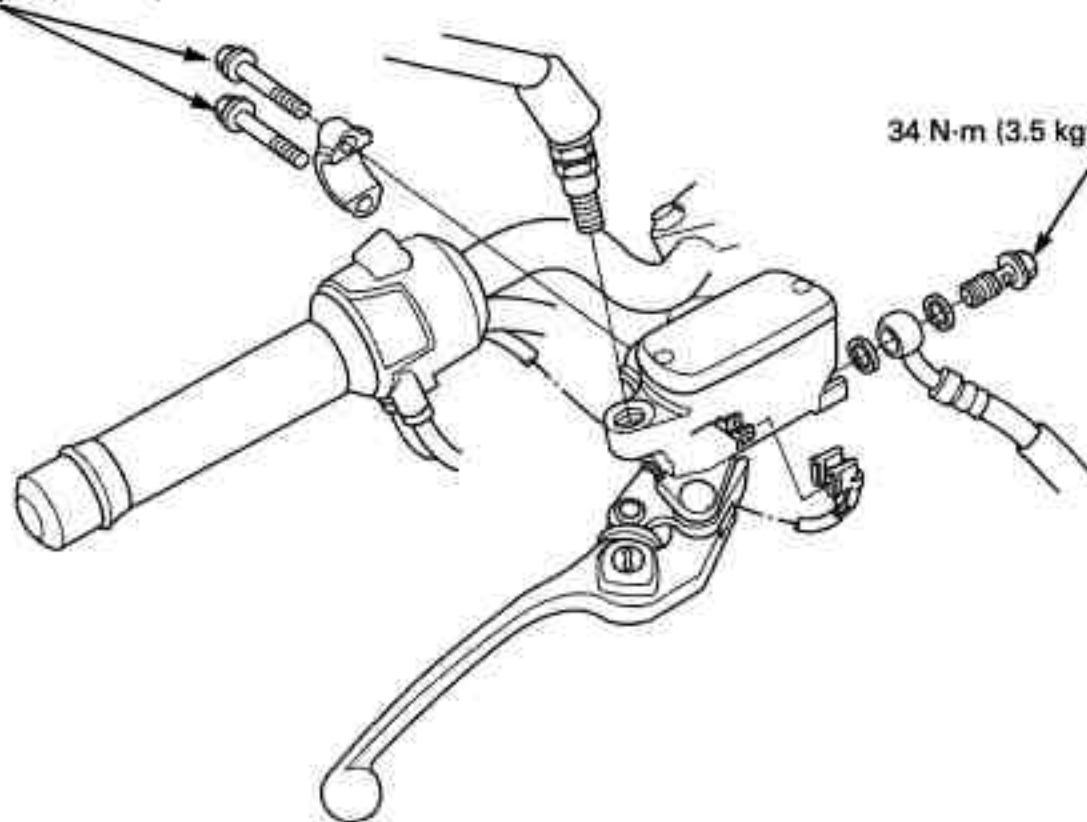

34 N·m (3.5 kgf·m, 25 lbf·ft)

34 N·m (3.5 kgf·m, 25 lbf·ft)

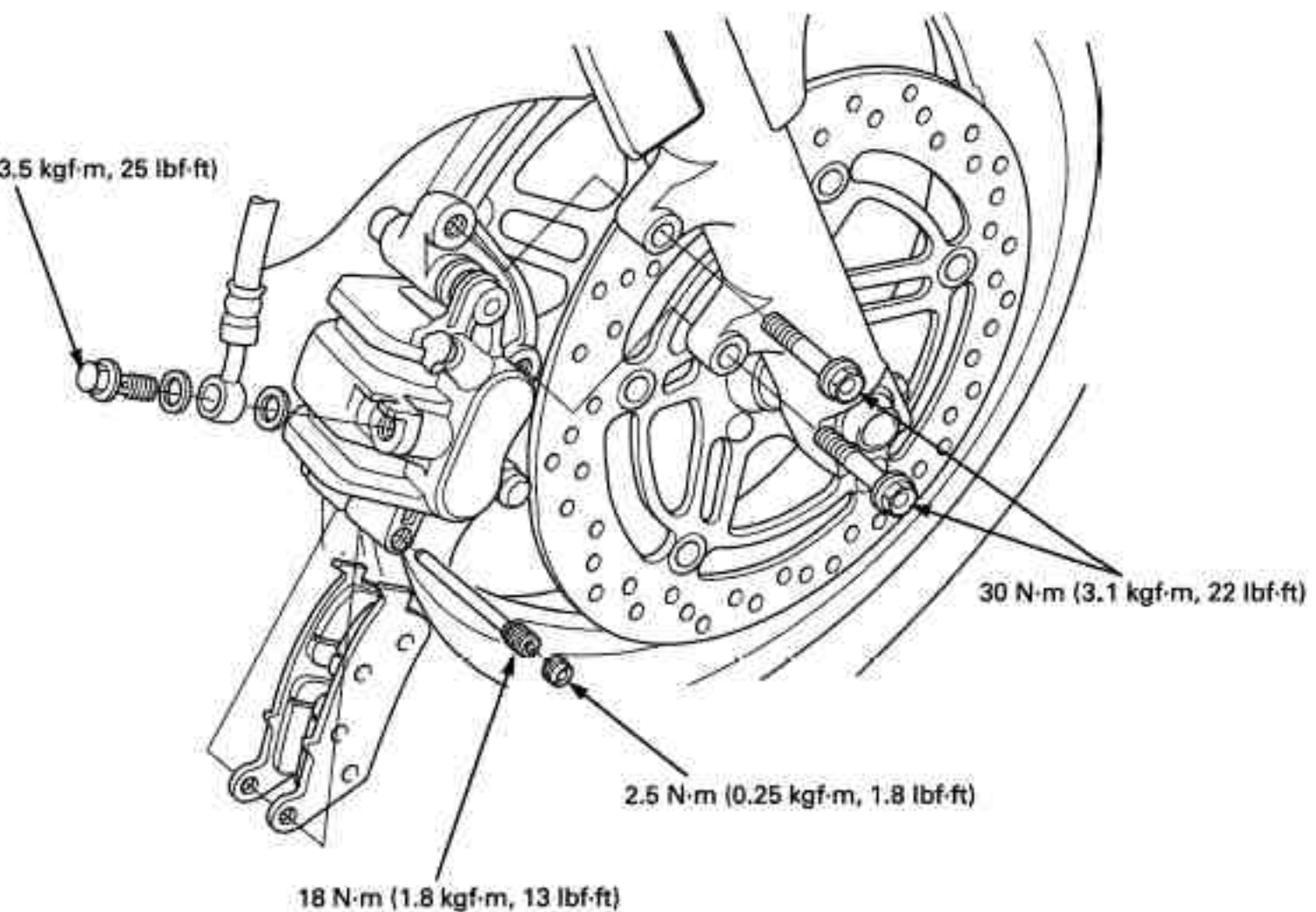

30 N·m (3.1 kgf·m, 22 lbf·ft)

2.5 N·m (0.25 kgf·m, 1.8 lbf·ft)

18 N·m (1.8 kgf·m, 13 lbf·ft)

REAR:

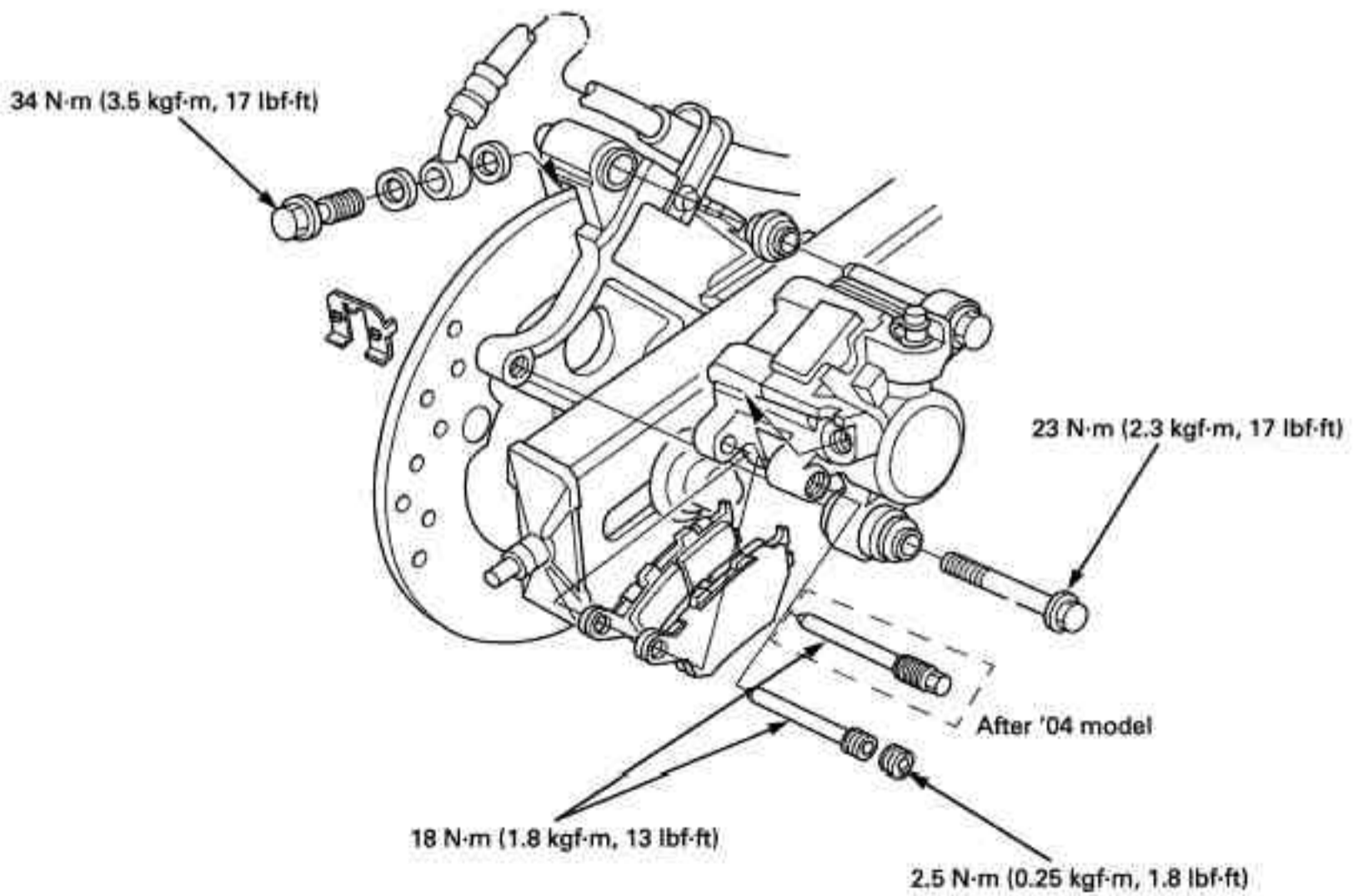
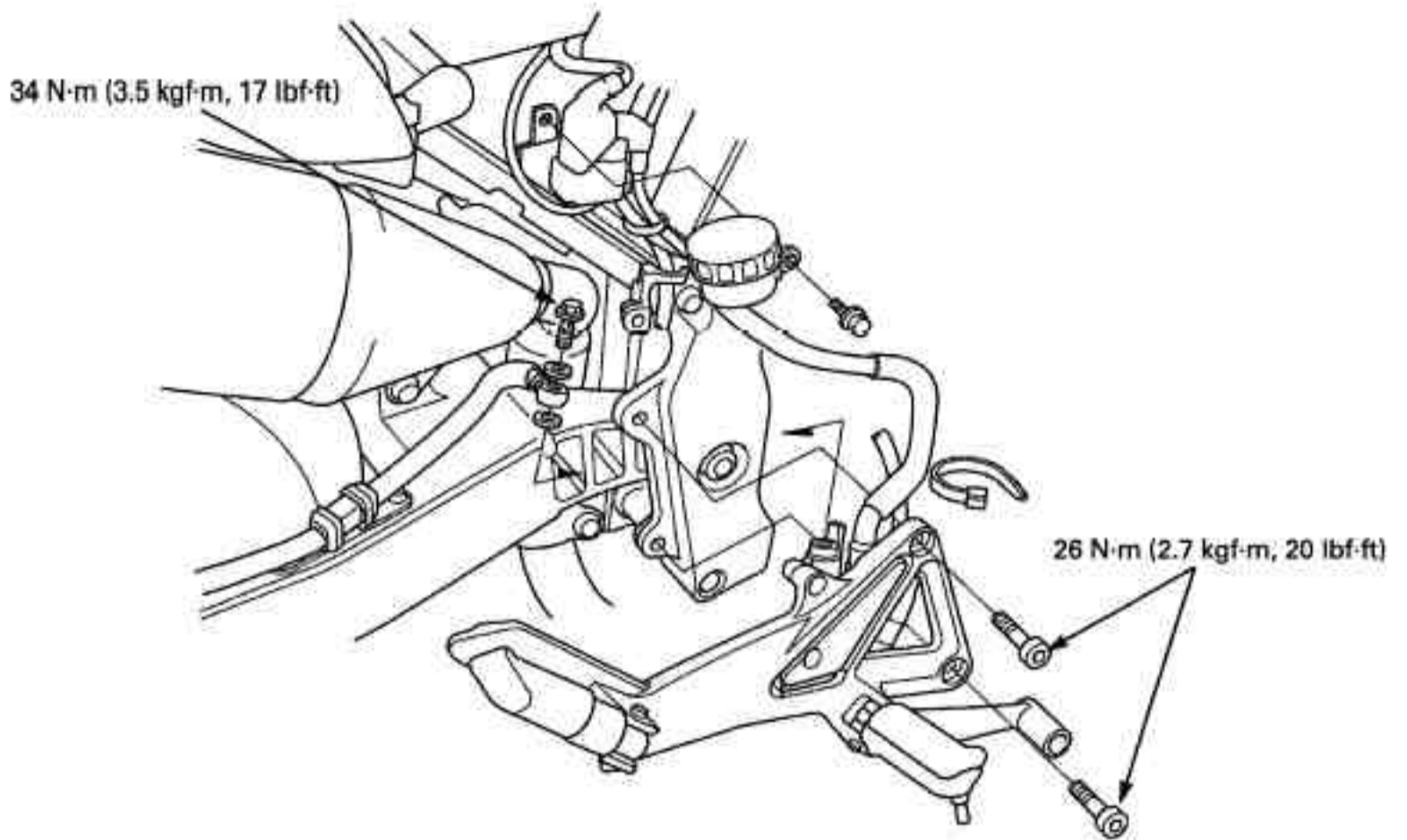

HYDRAULIC BRAKE

SERVICE INFORMATION

GENERAL

⚠ CAUTION

Frequent inhalation of brake pad dust, regardless of material composition could be hazardous to your health.

- Avoid breathing dust particles.
- Never use an air hose or brush to clean brake assemblies. Use an OSHA-approved vacuum cleaner.

NOTICE

Spilled brake fluid will severely damage instrument lenses and painted surfaces. It is also harmful to some rubber parts. Be careful whenever you remove the reservoir cap; make sure the front reservoir is horizontal first.

- A contaminated brake disc or pad reduces stopping power. Discard contaminated pads and clean a contaminated disc with a high quality brake degreasing agent.
- Check the brake system by applying the brake lever or pedal after the air bleeding.
- Never allow contaminants (dirt, water, etc.) to get into an open reservoir.
- Once the hydraulic system has been opened, or if the brake feels spongy, the system must be bled.
- Always use fresh DOT 4 brake fluid from a sealed container when servicing the system. Do not mix different types of fluid they may not be compatible.
- Always check brake operation before riding the motorcycle.

SPECIFICATIONS

Unit: mm (in)

ITEM		STANDARD	SERVICE LIMIT
Front	Specified brake fluid	DOT 4	-
	Brake disc thickness	4.5 (0.18)	3.5 (0.14)
	Brake disc runout	-	0.30 (0.012)
	Master cylinder I.D.	12.7 (0.50)	-
	Caliper cylinder I.D.	Upper Lower	32.03 (1.261) 30.23 (1.190)
Rear	Specified brake fluid	DOT 4	-
	Brake pedal height	67.5 (2.66)	-
	Brake disk thickness	5.0 (0.20)	4.0 (0.16)
	Brake disc runout	-	0.30 (0.012)
	Master cylinder I.D.	14.00 (0.551)	-
	Caliper cylinder I.D.	33.96 (1.337)	-

TORQUE VALUES

Front brake master cylinder holder bolt	12 N·m (1.2 kgf·m, 9 lbf·ft)	
Front brake master cylinder reservoir cap screw	1.5 N·m (0.15 kgf·m, 1.1 lbf·ft)	
Brake lever pivot bolt	0.9 N·m (0.10 kgf·m, 0.7 lbf·ft)	
Brake lever pivot nut	5.9 N·m (0.60 kgf·m, 4.3 lbf·ft)	
Front brake light switch screw	1.2 N·m (0.12 kgf·m, 0.9 lbf·ft)	
Front brake caliper mounting bolt	30 N·m (3.1 kgf·m, 22 lbf·ft)	ALOC bolt; replace with a new one
Front brake caliper pin bolt A	23 N·m (2.3 kgf·m, 17 lbf·ft)	Apply a locking agent to the threads
Front brake caliper pin bolt	13 N·m (1.3 kgf·m, 9 lbf·ft)	Apply a locking agent to the threads
Pad pin	18 N·m (1.8 kgf·m, 13 lbf·ft)	
Pad pin plug	2.5 N·m (0.25 kgf·m, 1.8 lbf·ft)	
Front brake hose clamp bolt	12 N·m (1.2 kgf·m, 9 lbf·ft)	'04 model ALOC bolt; replace with a new one After '04 model
Front brake hose clamp cap nut	12 N·m (1.2 kgf·m, 9 lbf·ft)	
Brake caliper bleeder	5.4 N·m (0.55 kgf·m, 4 lbf·ft)	
Rear master cylinder mounting bolt	12 N·m (1.2 kgf·m, 9 lbf·ft)	
Rear master cylinder hose joint screw	1.5 N·m (0.15 kgf·m, 1.1 lbf·ft)	Apply a locking agent to the threads
Rear master cylinder push rod nut	18 N·m (1.8 kgf·m, 13 lbf·ft)	
Rear brake caliper main slide pin	27 N·m (2.8 kgf·m, 20 lbf·ft)	
Rear brake caliper sub slide pin	23 N·m (2.3 kgf·m, 17 lbf·ft)	ALOC bolt; replace with a new one
Rear brake hose clamp bolt	8.8 N·m (0.90 kgf·m, 6.5 lbf·ft)	ALOC bolt; replace with a new one
Brake hose oil bolt	34 N·m (3.5 kgf·m, 25 lbf·ft)	
Footpeg holder bolt	26 N·m (2.7 kgf·m, 20 lbf·ft)	

TOOL

Snap ring pliers
07914-SA50001

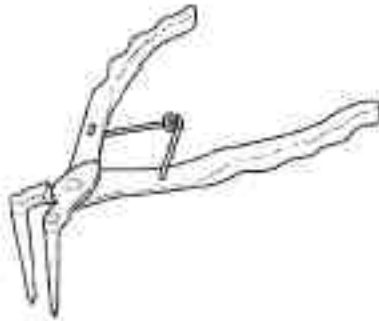

or 07914-3230001

TROUBLESHOOTING**Brake lever/pedal soft or spongy**

- Air in hydraulic system
- Leaking hydraulic system
- Contaminated brake pad/disc
- Worn caliper piston seal
- Worn master cylinder piston cups
- Worn brake pad/disc
- Contaminated caliper
- Caliper not sliding properly
- Low brake fluid level
- Clogged fluid passage
- Warped/deformed brake disc
- Sticking/worn caliper piston
- Sticking/worn master cylinder piston
- Contaminated master cylinder
- Bent brake lever/pedal

Brake lever/pedal hard

- Clogged/restricted brake system
- Sticking/worn caliper piston
- Caliper not sliding properly
- Clogged/restricted fluid passage
- Worn caliper piston seal
- Sticking/worn master cylinder piston
- Bent brake lever/pedal

Brake drags

- Contaminated brake pad/disc
- Misaligned wheel
- Warped/deformed brake disc
- Caliper not sliding properly
- Clogged/restricted brake hydraulic system
- Sticking/worn caliper piston

HYDRAULIC BRAKE

BRAKE FLUID REPLACEMENT/AIR BLEEDING

NOTICE

Spilled brake fluid will severely damage the plastic parts and painted surfaces. Place a shop towel over these parts whenever the system is serviced.

- Do not allow foreign material to enter the system when filling the reservoir.

BRAKE FLUID DRAINING

For the front brake, turn the handlebar to the left until the reservoir is parallel to the ground, before removing the reservoir cap.

Remove the screws and reservoir cap.

Remove the diaphragm plate and diaphragm.



For the rear brake, remove the right side cover (page 3-4).

Remove the reservoir cap.

Remove the diaphragm plate and diaphragm.



Connect a bleed hose to the caliper bleed valve.

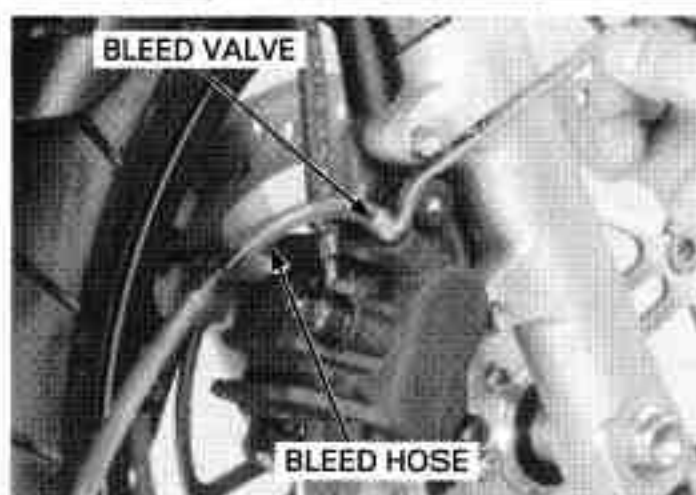

Loosen the bleed valve and pump the brake lever or pedal.
Stop pumping the lever or pedal when no more fluid flows out of the bleed valve.



BRAKE FLUID FILLING/AIR BLEEDING

Fill the reservoir with DOT 4 brake fluid from a sealed container.

NOTICE

- Use only DOT 4 brake fluid from a sealed container.
- Do not mix different types of fluid. They are not compatible.

Connect a commercially available brake bleeder to the bleed valve.

Operate the brake bleeder and loosen the bleed valve.

If not using an automatic refill system, adding fluid when the fluid level in the master cylinder reservoir is low.

- Check the fluid level often while bleeding the brakes to prevent air from being pumped into the system.
- When using a brake bleeding tool, follow the manufacturer's operating instructions.

Perform the bleeding procedure until the system is completely flushed/bled.

- If air is entering the bleeder from around the bleed valve threads, seal the threads with teflon tape.
- If a brake bleeder is not available, fill the master cylinder and operate the brake lever or pedal to fill the system.

Close the bleed valve.

Next, perform the available BLEEDING procedure.

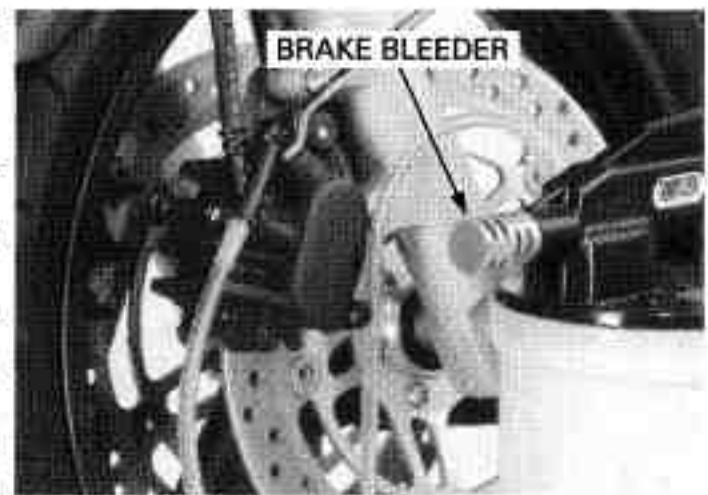

HYDRAULIC BRAKE

Connect a clear bleed hose to the bleed valve. Pump up the system pressure with the lever or pedal until there are no air bubbles in the fluid flowing out of the master cylinder and lever or pedal resistance is felt.

Do not release the brake lever or pedal until the bleed valve has been closed.

1. Squeeze the brake lever or push the brake pedal, open the bleed valve 1/2 turn and then close the valve.
2. Release the brake lever or pedal until the bleed valve has been closed.
3. Repeat steps 1 and 2 until bubbles cease to appear in the fluid coming out of the bleed valve.
4. Tighten the bleed valve.

TORQUE: 5.4 N·m (0.55 kgf·m, 4 lbf·ft)

Fill the fluid reservoir to the upper level.

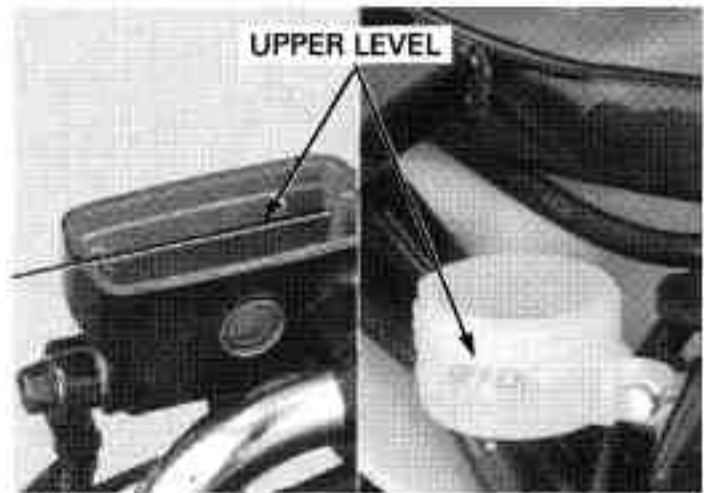
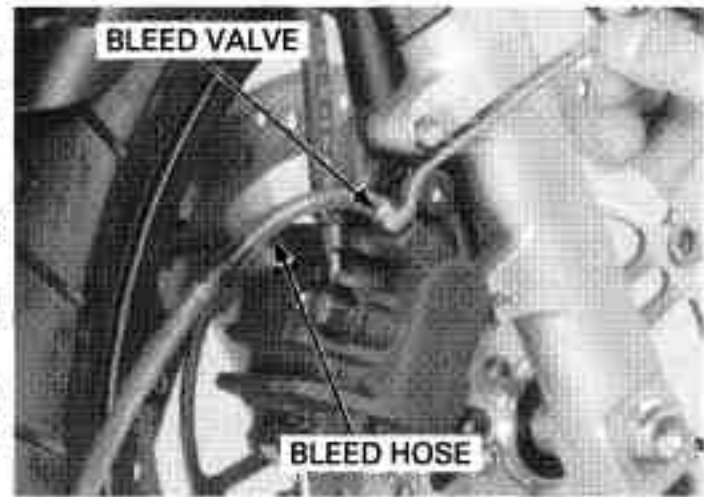

On the front brake, install the diaphragm and diaphragm plate. Install the reservoir cap, and tighten the screws to the specified torque.

TORQUE: 1.5 N·m (0.15 kgf·m, 1.1 lbf·ft)

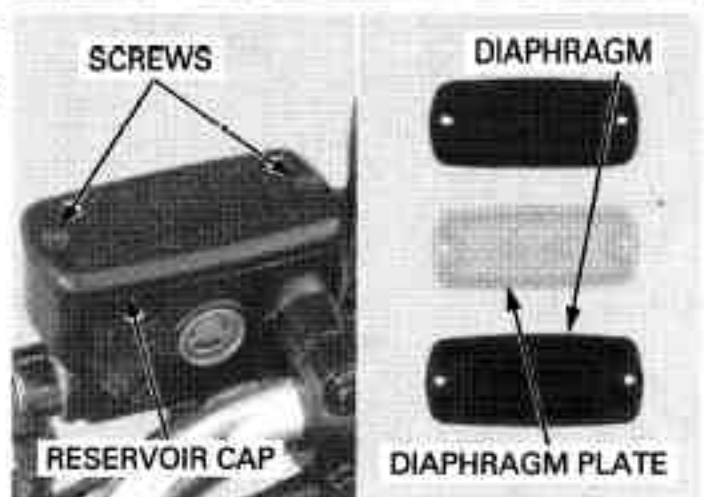

On the rear brake, install the diaphragm and diaphragm plate. Install the reservoir cap securely. Install the right side cover (page 3-4).

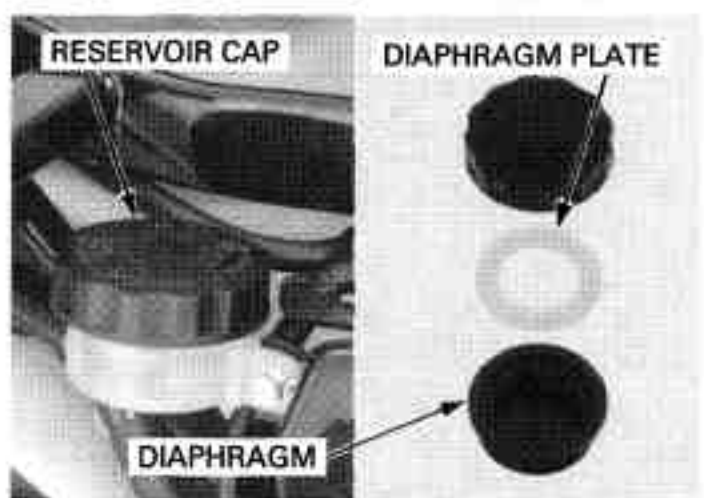

BRAKE PAD/DISC

FRONT BRAKE PAD REPLACEMENT

Check the brake fluid level in the brake master cylinder reservoir as this operation causes the level to rise.

Push the caliper pistons all the way in to allow installation of new brake pad.

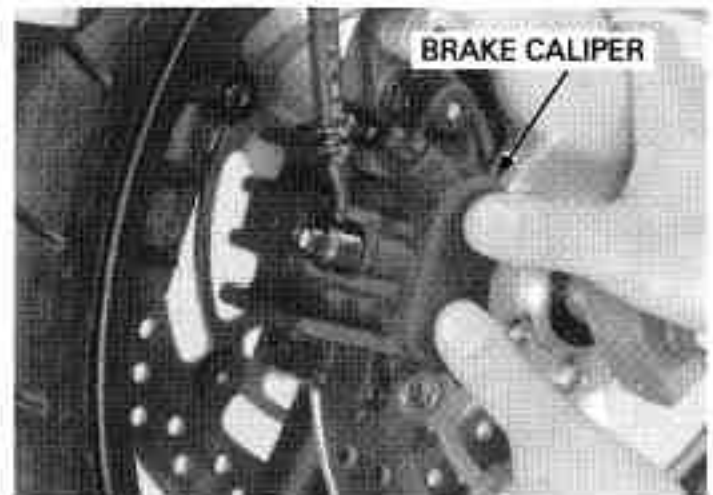

Remove the pad pin plug, then loosen the pad pin.

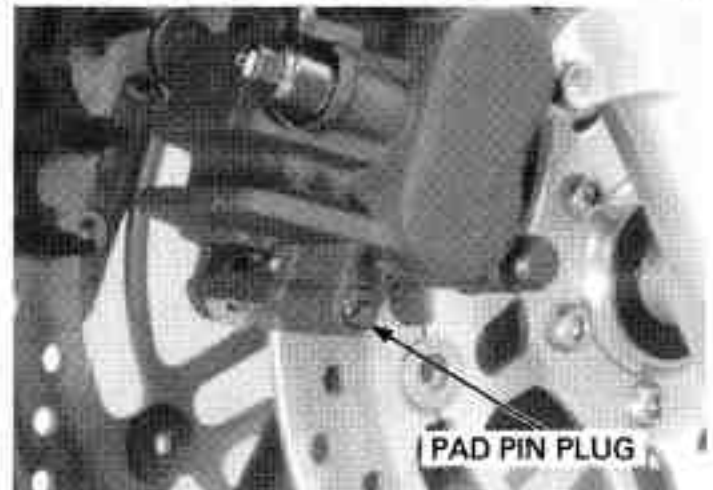

Remove the pad pin and brake pads.
Clean the brake caliper inside especially around the pistons.

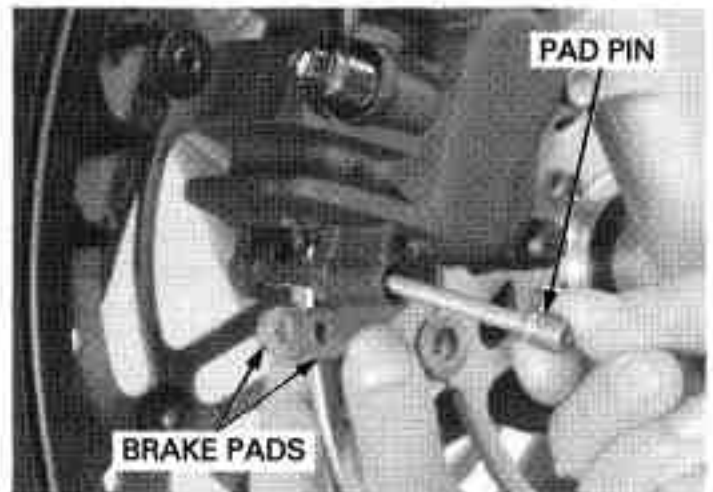

Make sure that the pad spring is in the place.

Always replace the brake pads in pairs to assure even disc pressure.

Install new brake pads.
Push the brake pads against the pad spring, then install the pad pin.

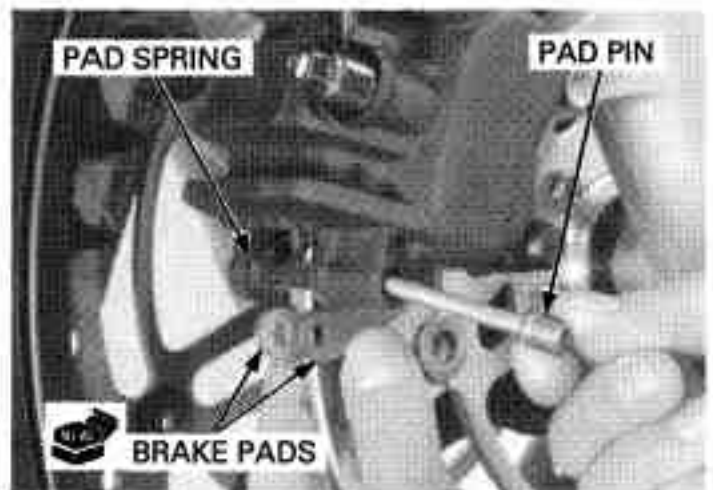

HYDRAULIC BRAKE

Tighten the pad pin to the specified torque.

TORQUE: 18 N·m (1.8 kgf·m, 13 lbf·ft)

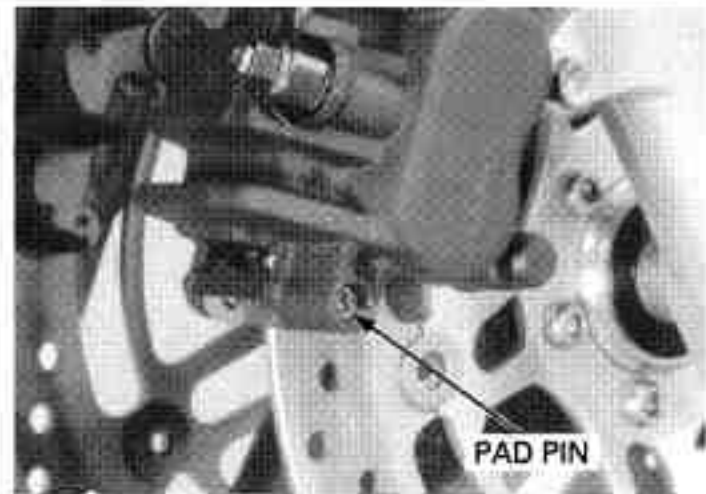

Install and tighten the pad pin plug to the specified torque.

TORQUE: 2.5 N·m (0.25 kgf·m, 1.8 lbf·ft)

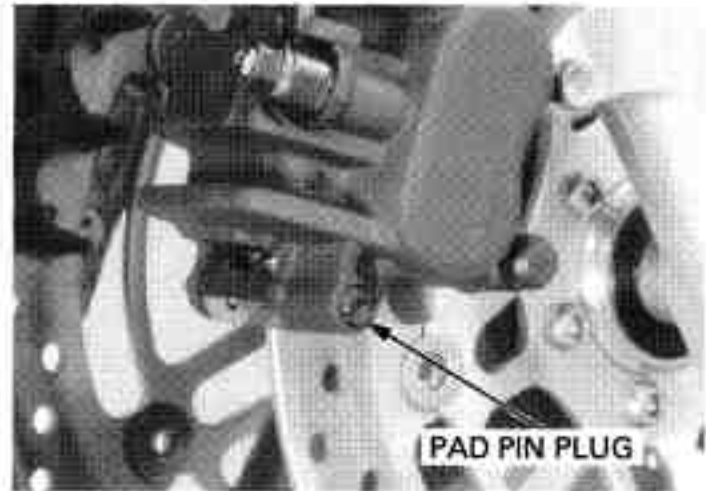

Check the brake fluid level in the brake master cylinder reservoir as this operation causes the level to rise.

REAR BRAKE PAD REPLACEMENT

Push the caliper pistons all the way in by pushing the caliper body inward to allow installation of new brake pads.



'04 model only: Remove the pad pin plug.

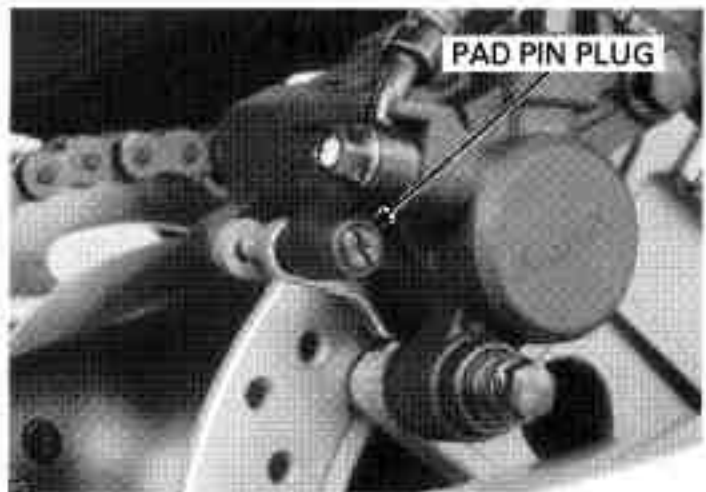

Loosen the pad pin.
Remove the caliper sub slide pin.

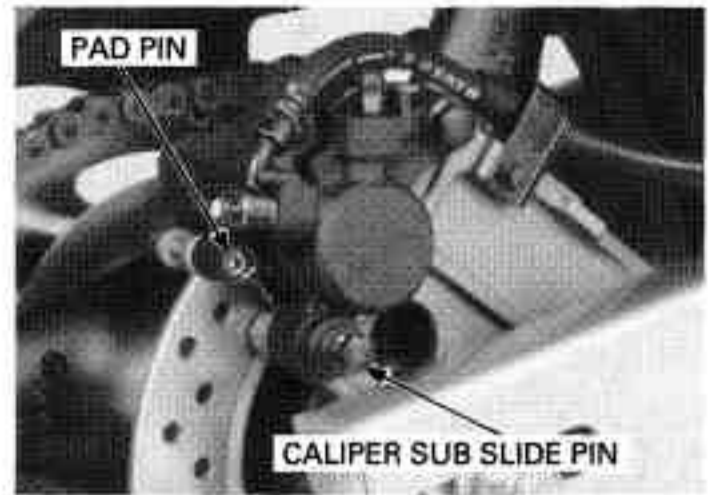

Pivot the caliper up.
Remove the pad pin and brake pads.
Clean the brake caliper inside especially around the pistons.

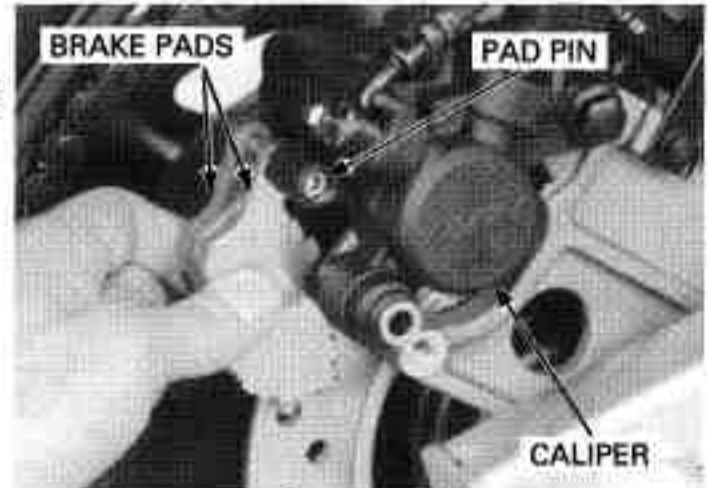

Make sure the brake pad spring is in place.

Always replace the brake pads in pairs to assure even disc pressure.

Install new brake pads.

Lower the caliper while pushing the pads against the pad spring so that the pad ends are positioned onto the retainer on the caliper bracket.

Install the pad pin.

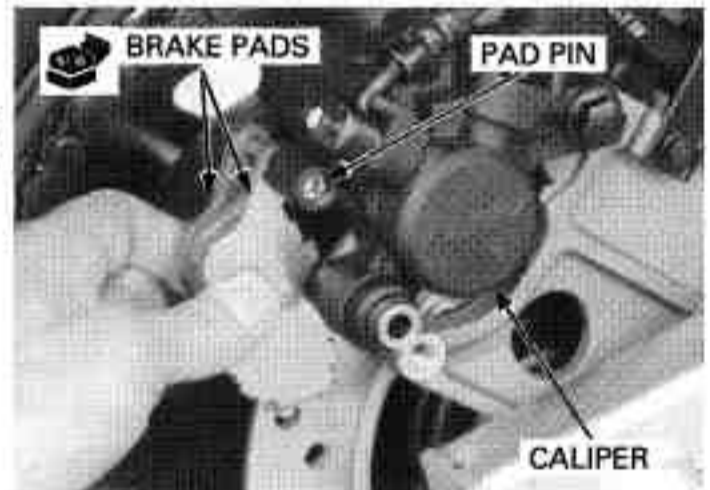

Install and tighten new caliper sub slide pin to the specified torque.

TORQUE: 23 N·m (2.3 kgf·m, 17 lbf·ft)

Tighten the pad pin to the specified torque.

TORQUE: 18 N·m (1.8 kgf·m, 13 lbf·ft)

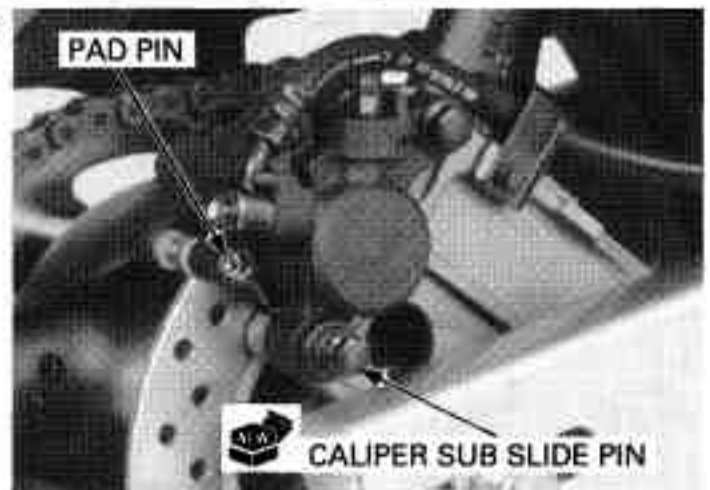

HYDRAULIC BRAKE

'04 model only. Install and tighten the pad pin plug to the specified torque.

TORQUE: 2.5 N·m (0.25 kgf·m, 1.8 lbf·ft)

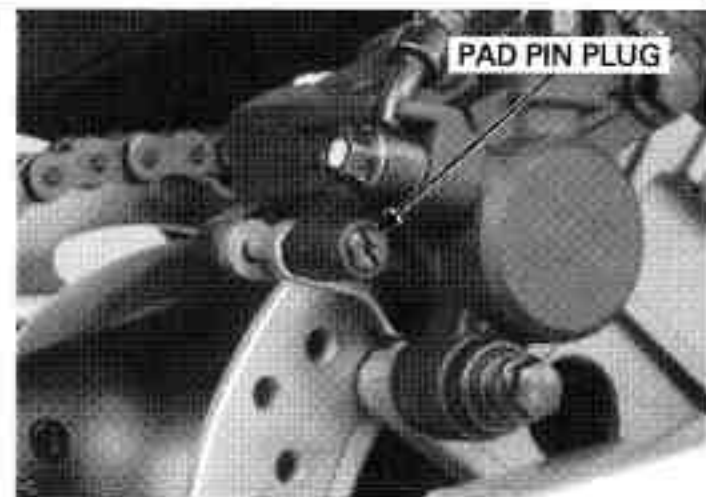

BRAKE DISC INSPECTION

Visually inspect the brake disc for damage or crack. Measure the brake disc thickness with a micrometer.

SERVICE LIMITS:

FRONT: 3.5 mm (0.14 in)

REAR: 4.0 mm (0.16 in)

Replace the brake disc if the smallest measurement is less than the service limit.

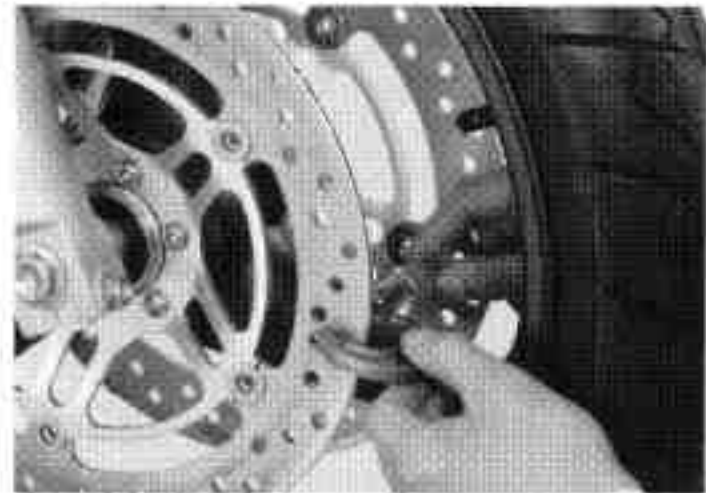

Measure the brake disc warpage with a dial indicator.

SERVICE LIMITS:

FRONT: 0.30 mm (0.012 in)

REAR: 0.30 mm (0.012 in)

Check the wheel bearings for excessive play, if the warpage exceeds the service limit.

Replace the brake disc if the wheel bearings are normal.



FRONT MASTER CYLINDER

REMOVAL

Remove the rear view mirror (page 14-8).
Drain the front hydraulic system (page 16-6).

Disconnect the brake light switch wire connectors.



Avoid spilling fluid on painted, plastic, or rubber parts. Place a rag over these parts whenever the system is serviced.

Remove the brake hose oil bolt, sealing washers and brake hose eyelet.

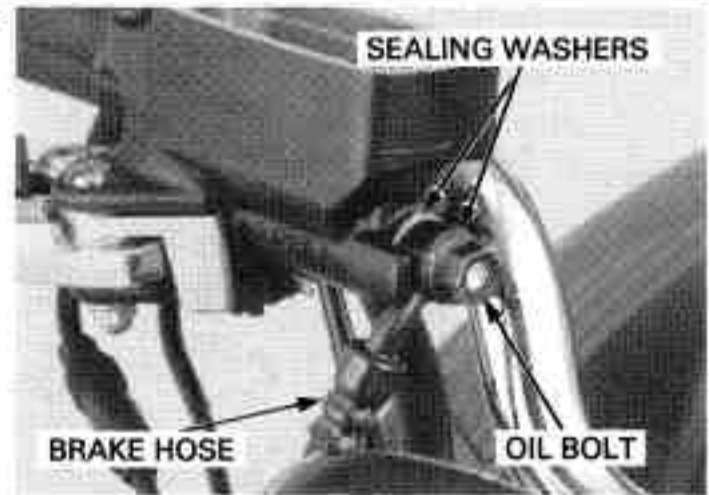

Remove the bolts from the master cylinder holder and remove the master cylinder assembly.

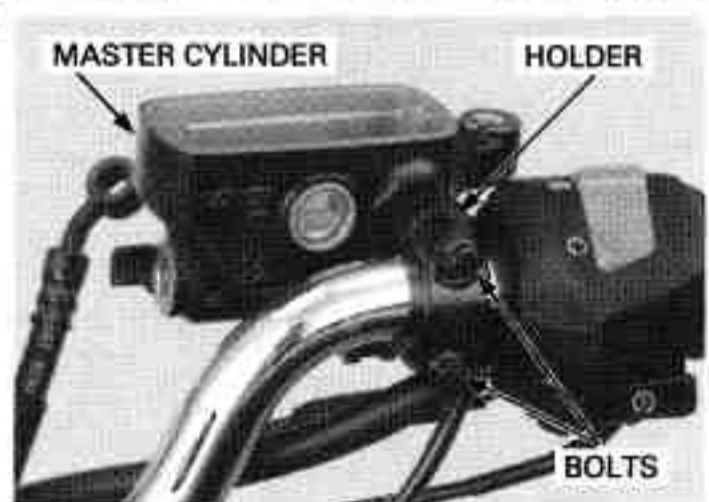

DISASSEMBLY

Remove the pivot bolt/nut and brake lever assembly.

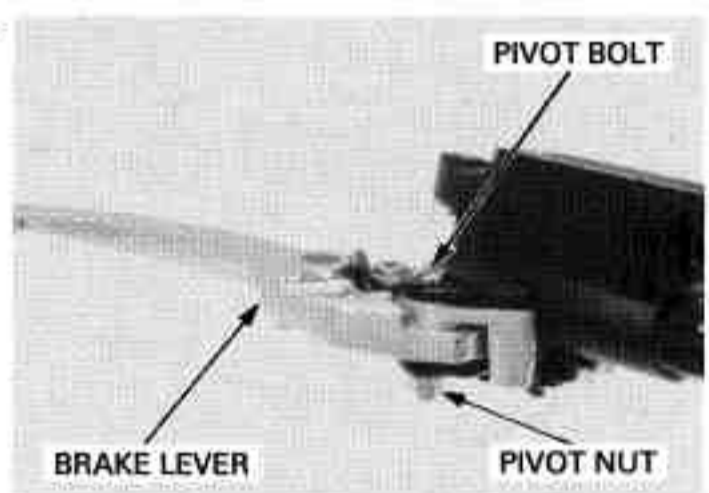

Remove the screw and brake light switch.

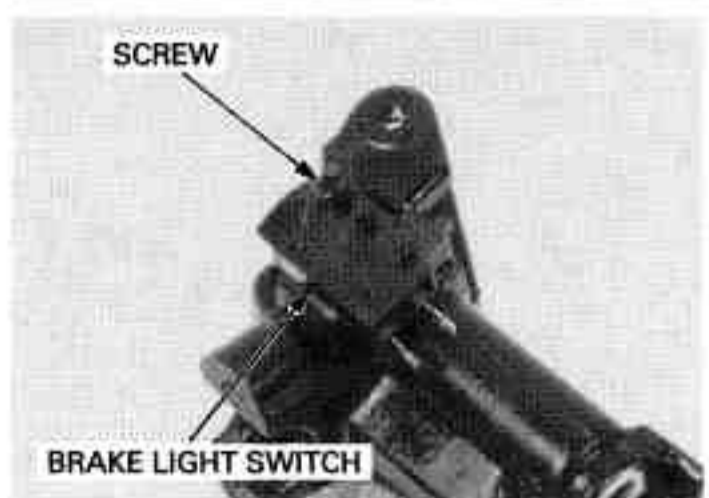

HYDRAULIC BRAKE

Remove the boot.

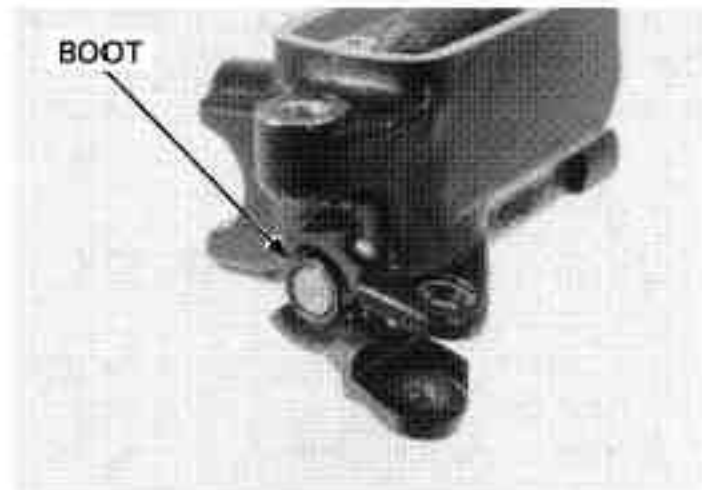

Remove the snap ring from the master cylinder body using the special tool as shown.

TOOL:

Snap ring pliers 07914-SA50001 or
07914-3230001

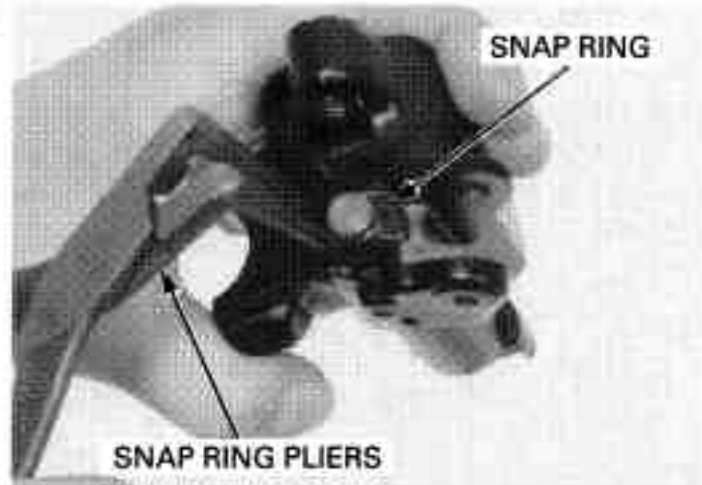

Remove the master piston and spring.

Clean the inside of the cylinder and reservoir with
brake fluid.

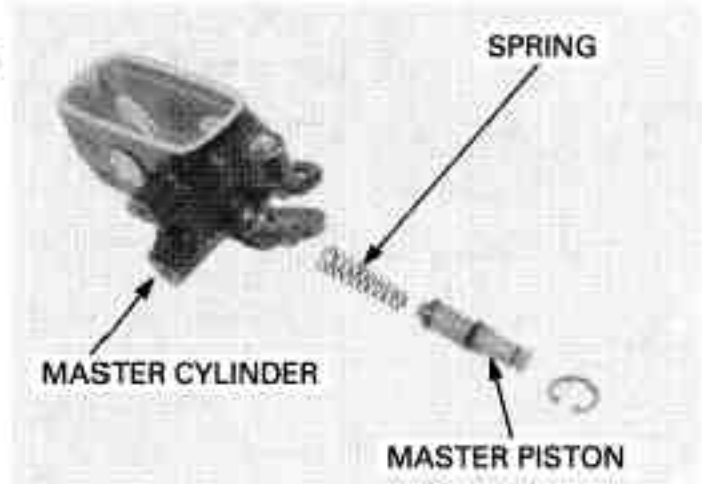

INSPECTION

Check the piston boot, primary cup and secondary
cup for fatigue or damage.
Check the master cylinder and piston for abnormal
scratches.

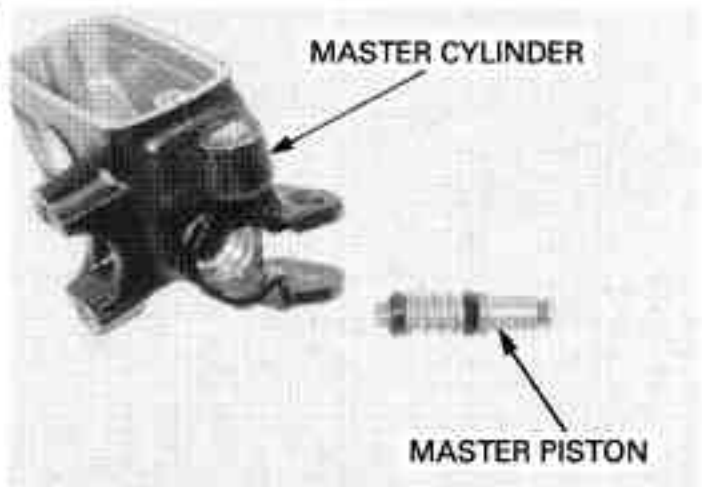

ASSEMBLY

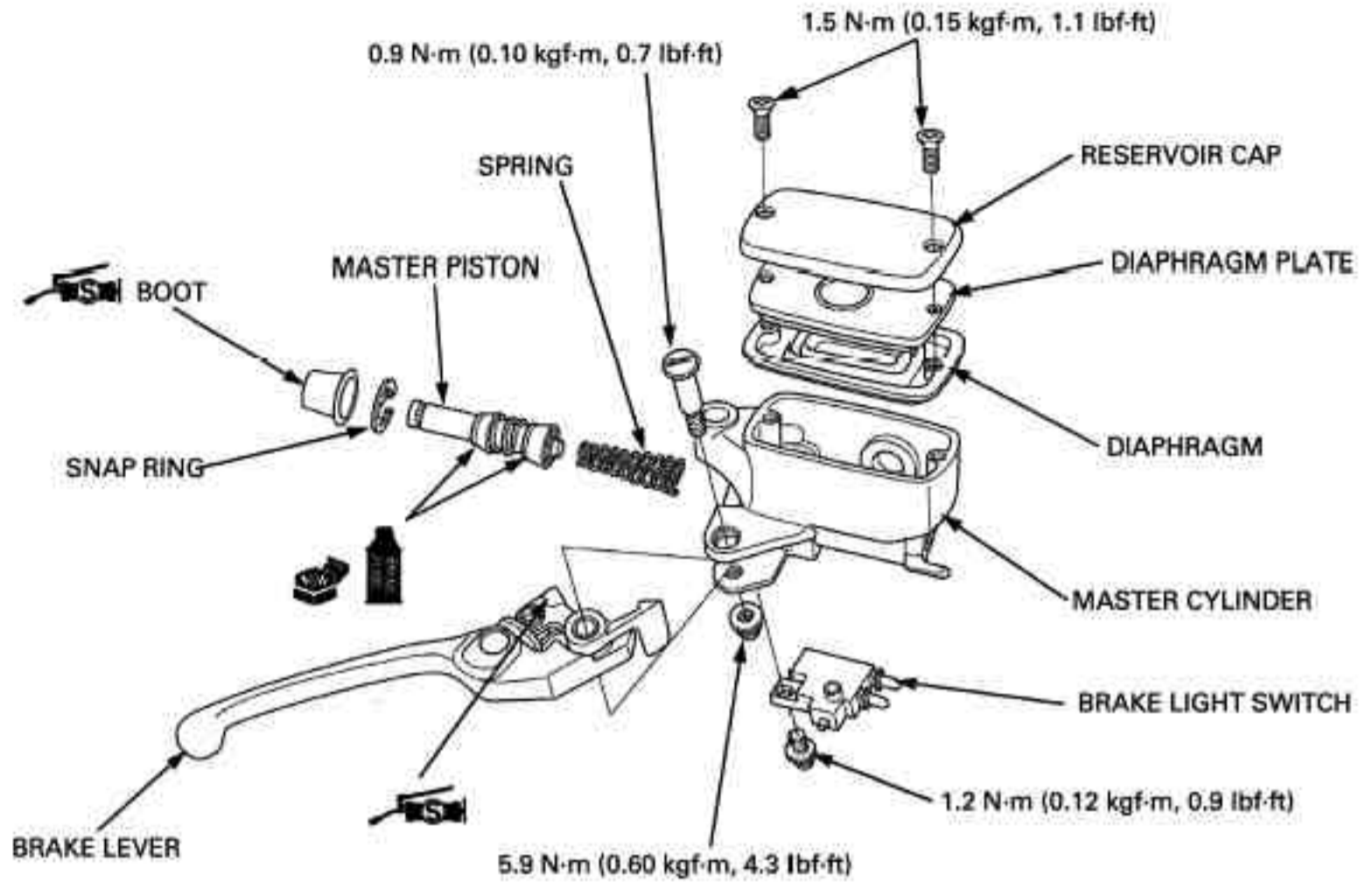

Keep the piston, cups, spring, snap ring and boot as a set; do not substitute individual parts.

Coat all parts with clean brake fluid before assembly.

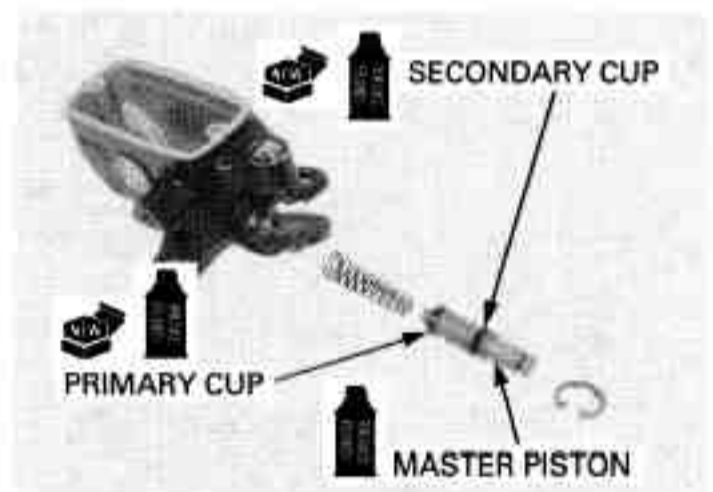

When installing the cups, do not allow the lips to turn inside out.

Dip the piston in brake fluid. Install the primary and secondary cups onto the master piston. Install the spring onto the tip of the master piston. Install the spring/primary cup and piston assembly into the master cylinder.

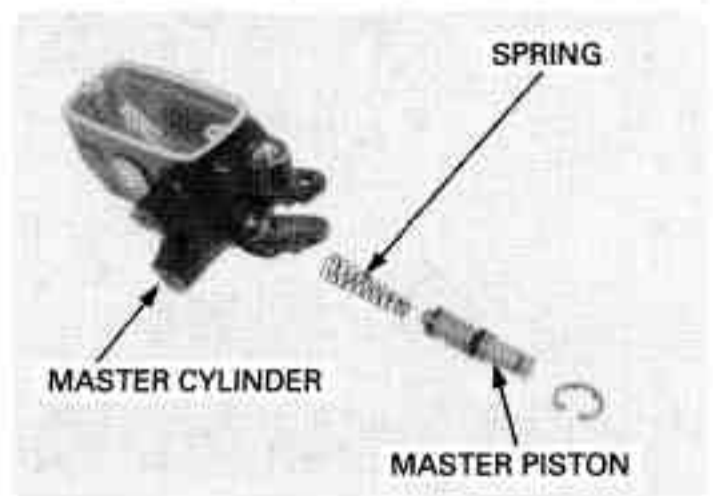

HYDRAULIC BRAKE

Be certain the snap ring is firmly seated in the groove.

Install the snap ring using the special tool as shown.

TOOL:

Snap ring pliers 07914-SA50001 or
07914-3230001

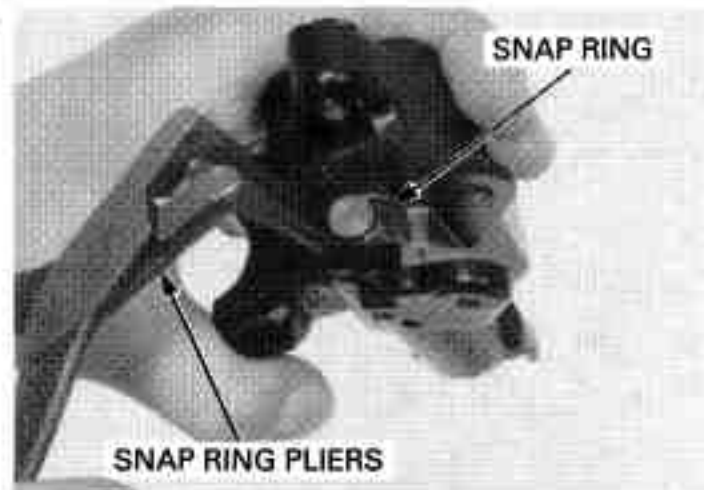

Install the boot.

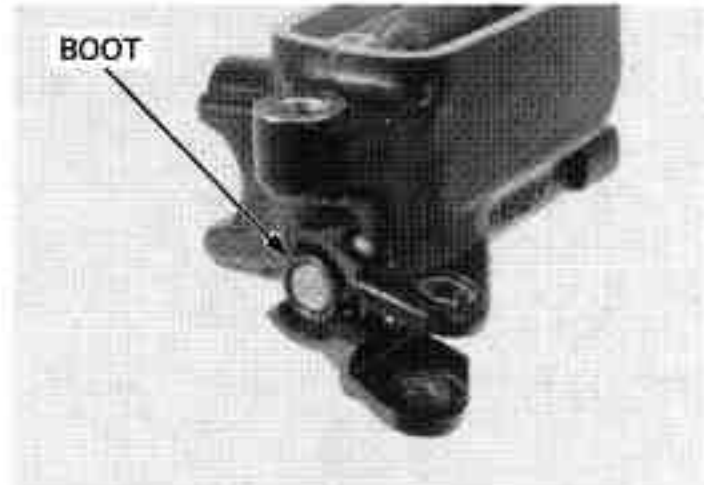

Install the brake light switch and tighten the screw to the specified torque.

TORQUE: 1.2 N-m (0.12 kgf-m, 0.9 lbf-ft)

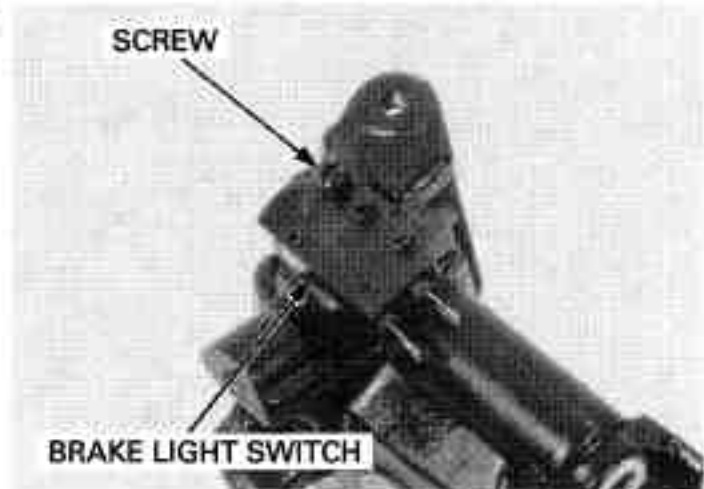

Apply silicone grease to the contact surfaces of the brake lever and piston tip.

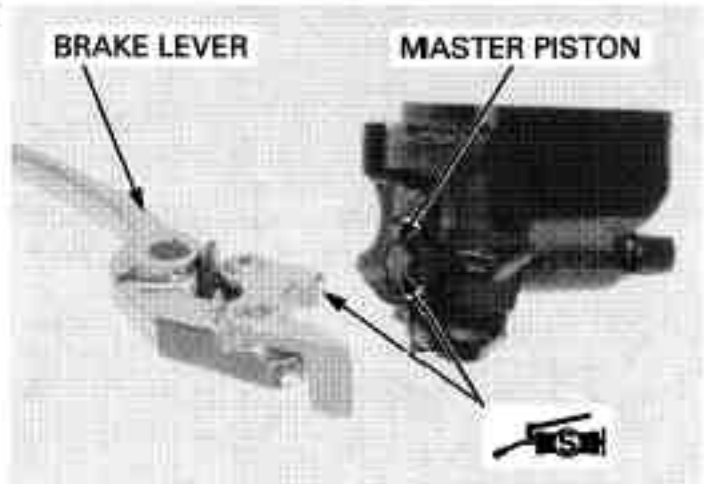

Install the brake lever assembly, tighten the pivot bolt to the specified torque.

TORQUE: 0.9 N-m (0.10 kgf-m, 0.7 lbf-ft)

Hold the pivot bolt and tighten the pivot nut to the specified torque.

TORQUE: 5.9 N-m (0.60 kgf-m, 4.3 lbf-ft)

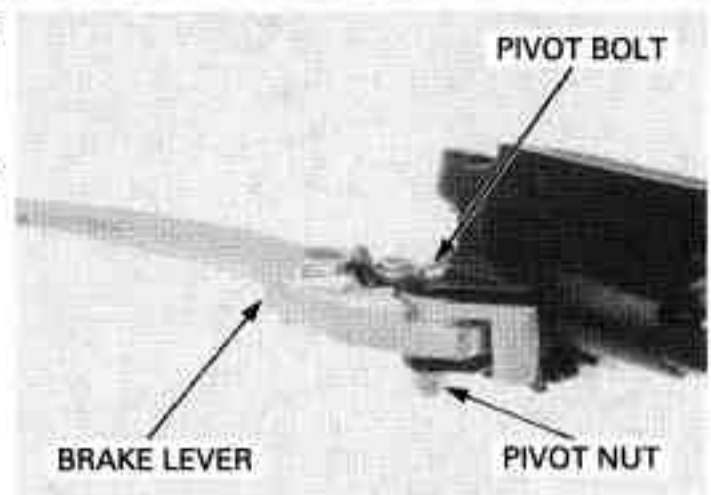

INSTALLATION

Place the master cylinder assembly on the handlebar.

Align the end of the master cylinder with the punch mark on the handlebar.

Install the master cylinder holder with the "UP" mark facing up.

Tighten the upper bolt first, then the lower bolt to the specified torque.

TORQUE: 12 N-m (1.2 kgf-m, 9 lbf-ft)

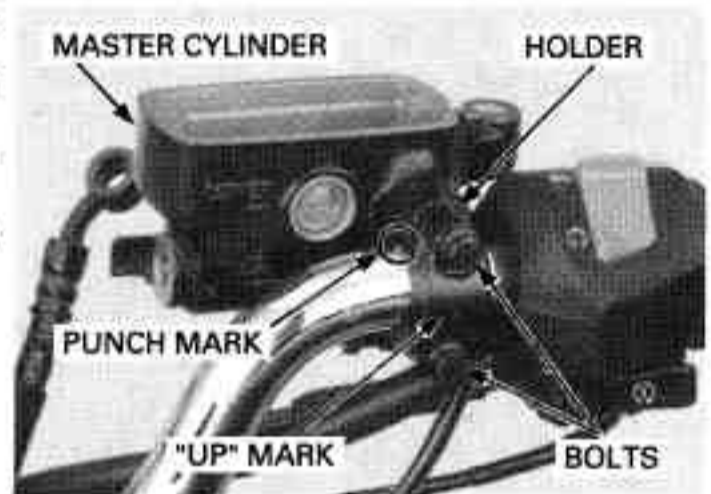

Install the brake hose eyelet with the oil bolt and new sealing washers.

Push the eyelet joint against the stopper, then tighten the oil bolt to the specified torque.

TORQUE: 34 N-m (3.5 kgf-m, 25 lbf-ft)



Connect the brake light switch wire connectors.

Fill the reservoir to the upper level (page 16-7) and bleed the brake system (page 16-7).

Install the rear view mirror (page 14-10).

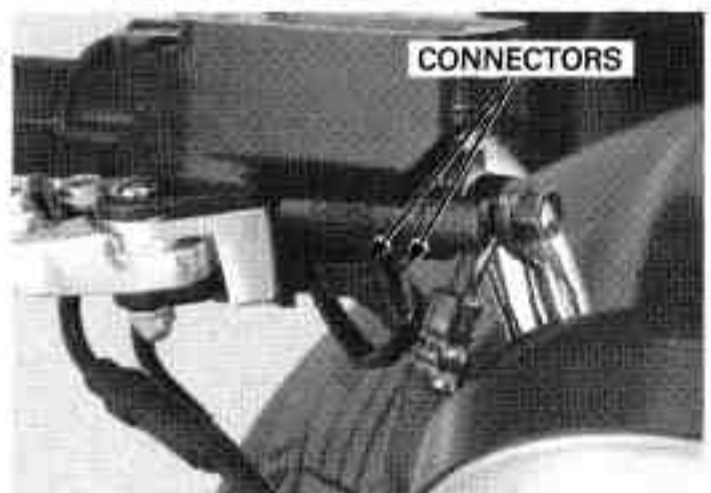

HYDRAULIC BRAKE

REAR MASTER CYLINDER

REMOVAL

Drain the rear hydraulic system (page 16-6).

Remove the bolt and rear master cylinder reservoir.

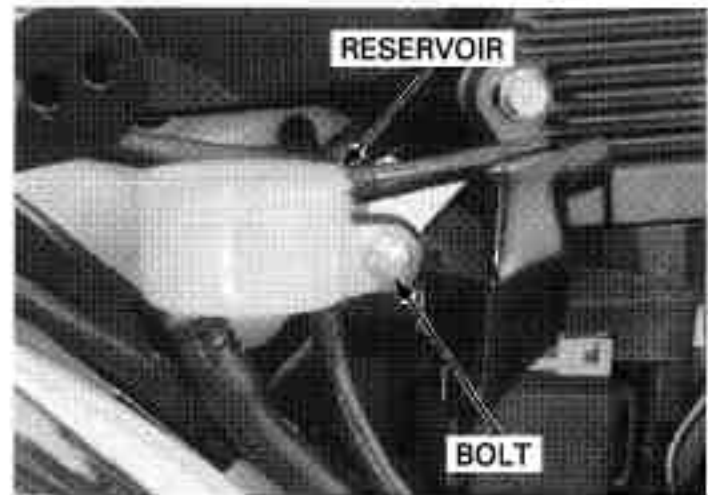

Avoid spilling fluid on painted, plastic, or rubber parts. Place a rag over these parts whenever the system is serviced.

Remove the brake hose oil bolt, sealing washers and brake hose.



Remove the reservoir hose from the clamp. Remove the wire band.

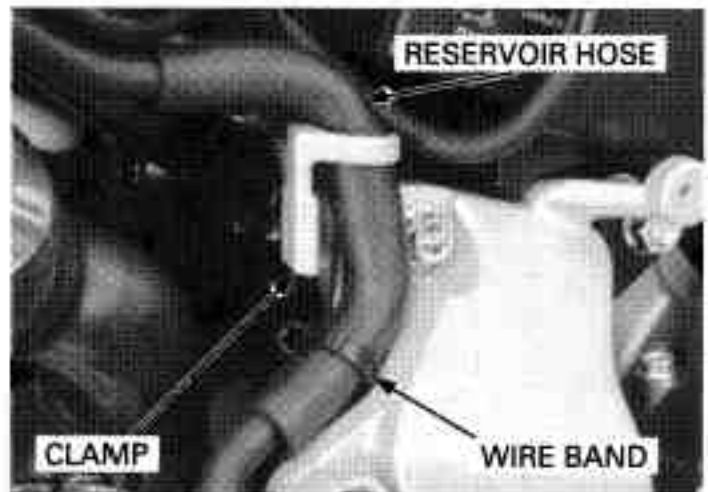

Loosen the rear master cylinder mounting bolts. Remove the bolts and right footpeg holder assembly.

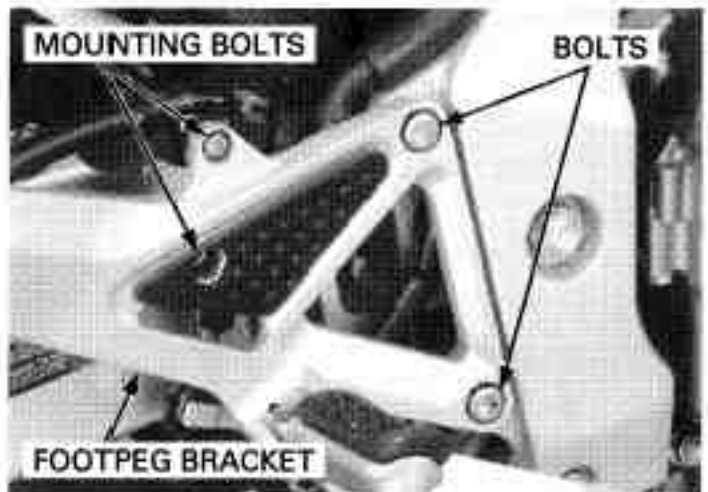

Remove and discard the brake pedal joint cotter pin. Remove the joint pin.

Remove the master cylinder mounting bolts and rear master cylinder.

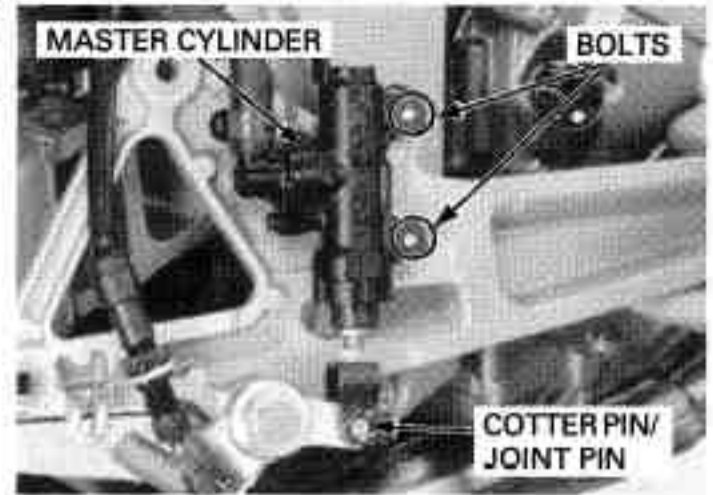

DISASSEMBLY

Remove the hose clamp, then remove the reservoir cup from the reservoir hose.

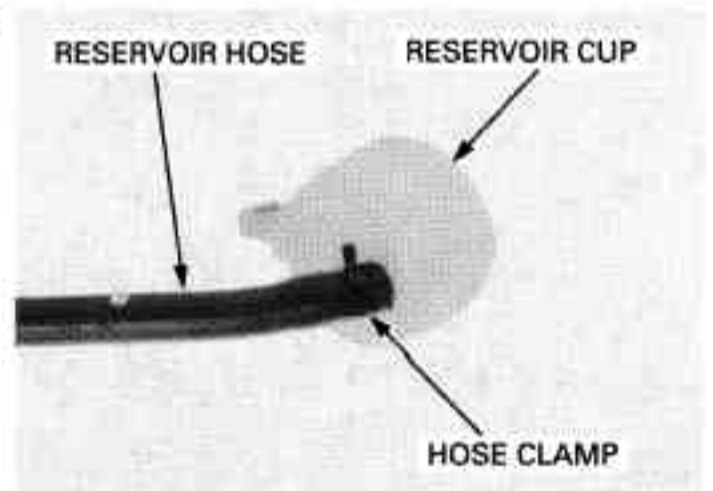

Remove the screw and reservoir hose joint and O-ring from the master cylinder.

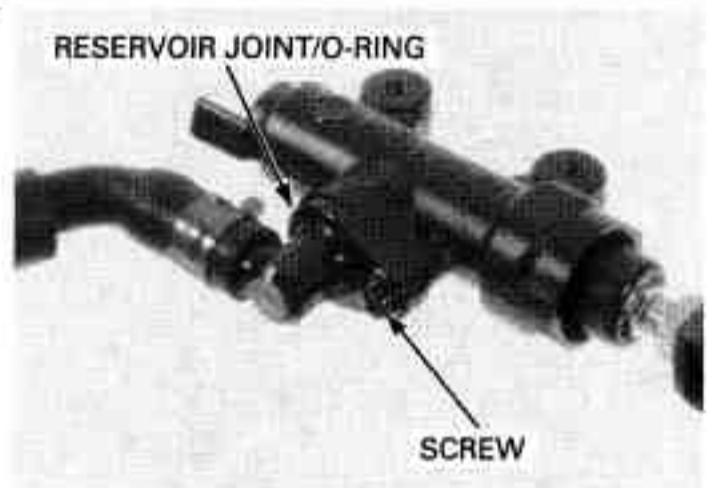

Remove the boot.

Remove the snap ring from the master cylinder body using the special tool as shown.

TOOL:

Snap ring pliers 07914-SA50001 or 07914-3230001

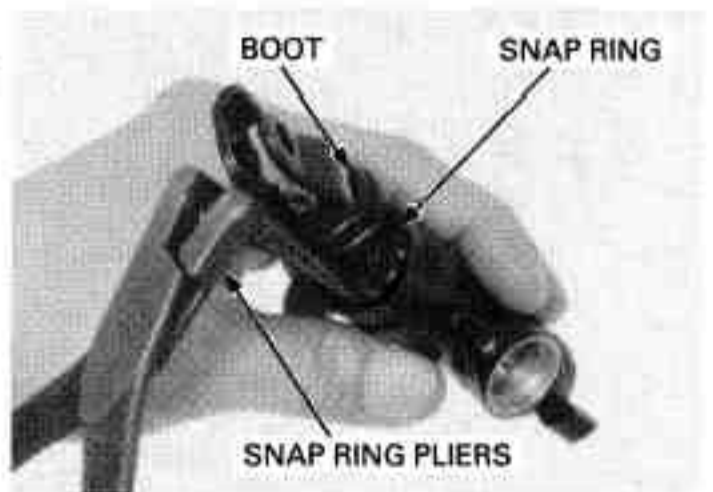

HYDRAULIC BRAKE

Remove the push rod, master piston, primary cup and spring.

Clean the inside of the cylinder with brake fluid.

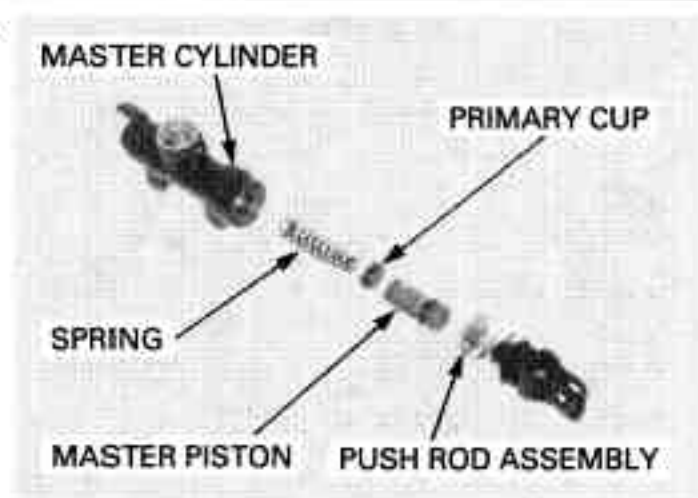

INSPECTION

Check the piston boot, primary cup and secondary cup for fatigue or damage.
Check the master cylinder and piston for abnormal scratches.

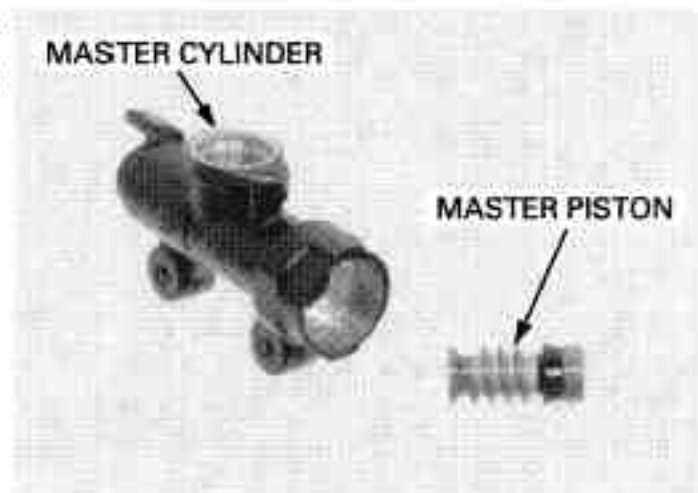

ASSEMBLY

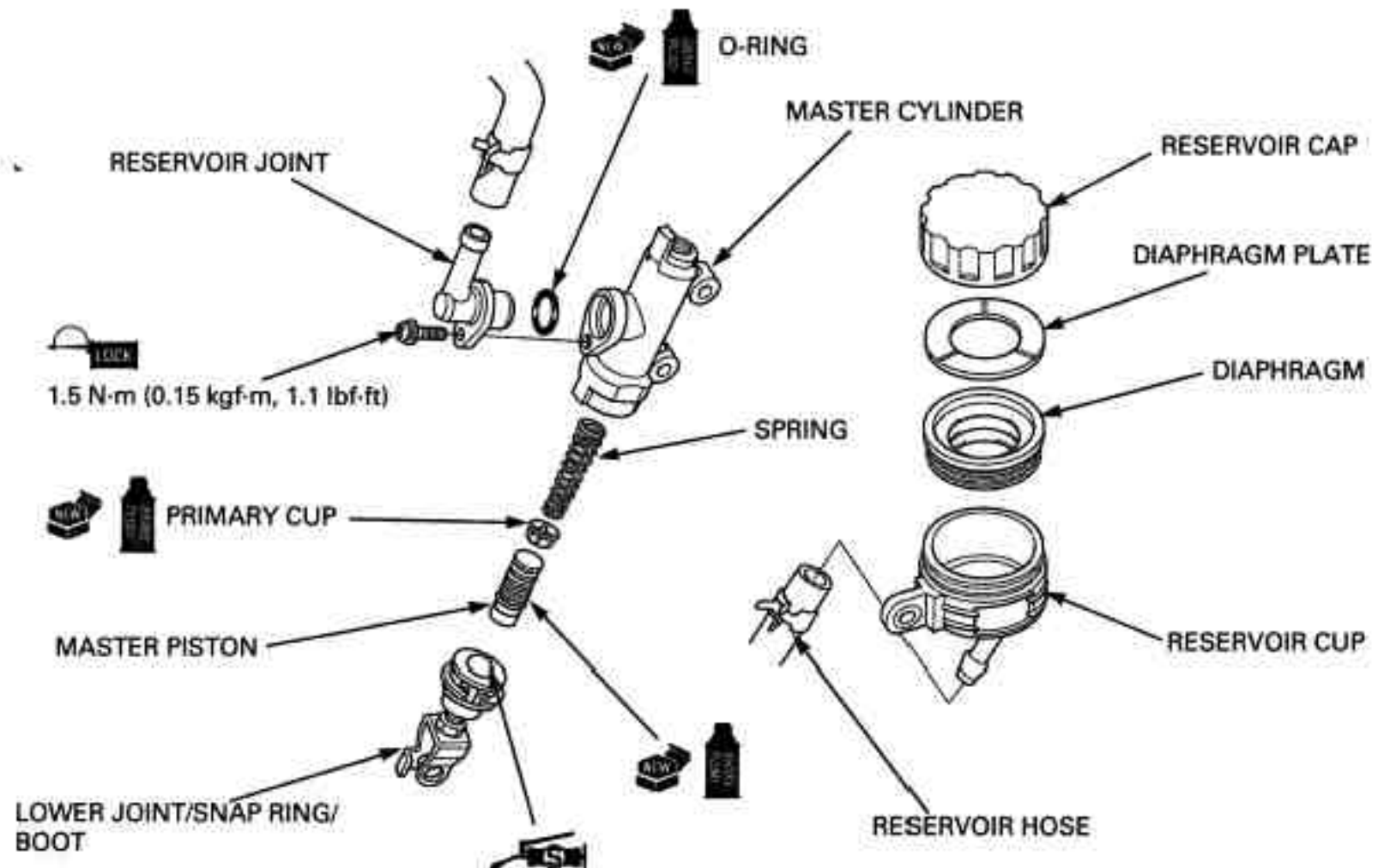

Keep the piston, cups, spring, snap ring and boot as a set; do not substitute individual parts.

Coat all parts with clean brake fluid before assembly.

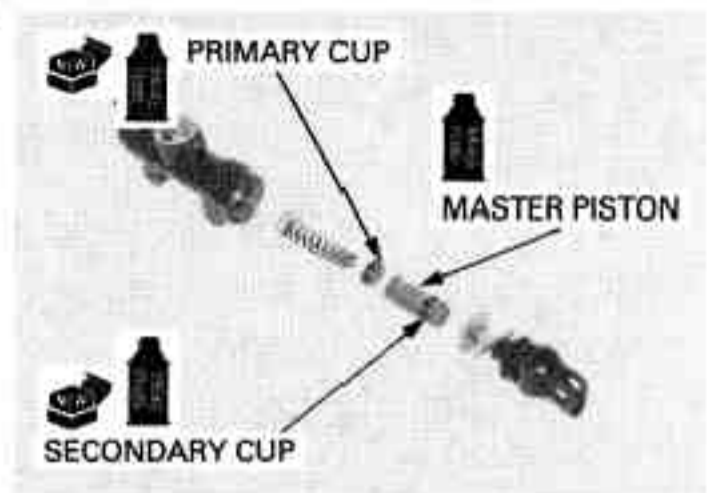

When installing the cups, do not allow the lips to turn inside out.

Dip the piston in brake fluid. Install the primary cup to the spring. Apply silicone grease to the piston contact area of the push rod. Install the spring/primary cup and master piston assembly.

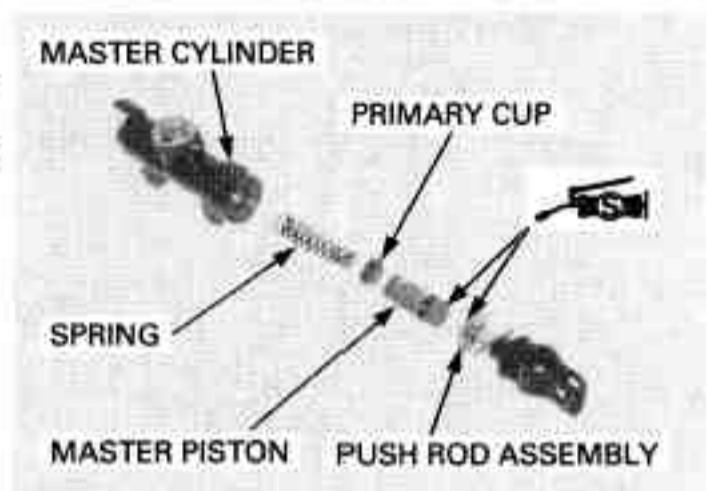

Be certain the snap ring is firmly seated in the groove.

Install the push rod into the master cylinder.

Install the snap ring using the special tool as shown.

TOOL:
Snap ring pliers 07914-SA50001 or 07914-3230001

Install the boot.

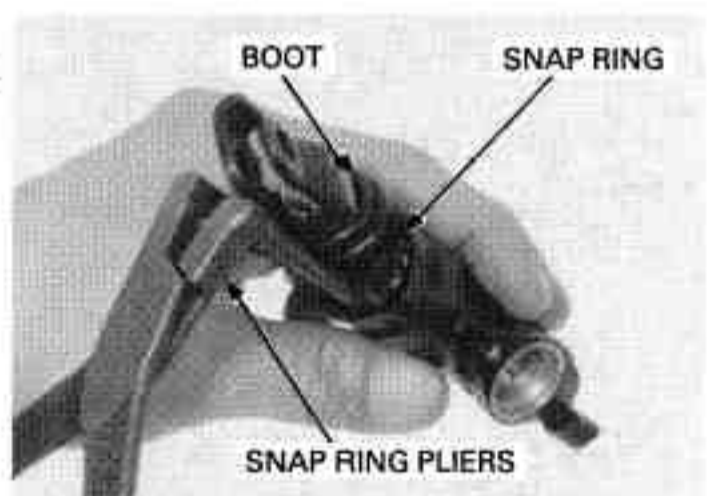

If the push rod is disassembled, adjust the push rod length as shown. After adjustment, tighten the lock nut to the specified torque.

TORQUE: 18 N-m (1.8 kgf-m, 13 lbf-ft)

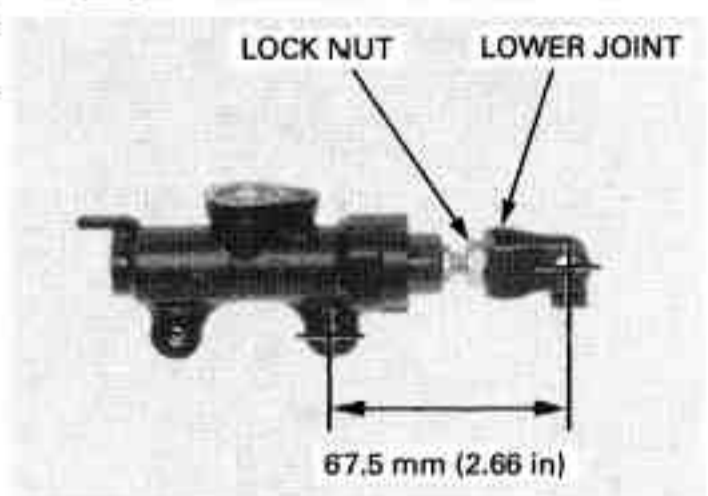

HYDRAULIC BRAKE

Apply brake fluid to a new O-ring and install it onto the reservoir joint.
Install the reservoir joint into the master cylinder.



Apply a locking agent to the reservoir joint screw threads.

Install and tighten the screw to the specified torque.

TORQUE: 1.5 N·m (0.15 kgf·m, 1.1 lbf·ft)

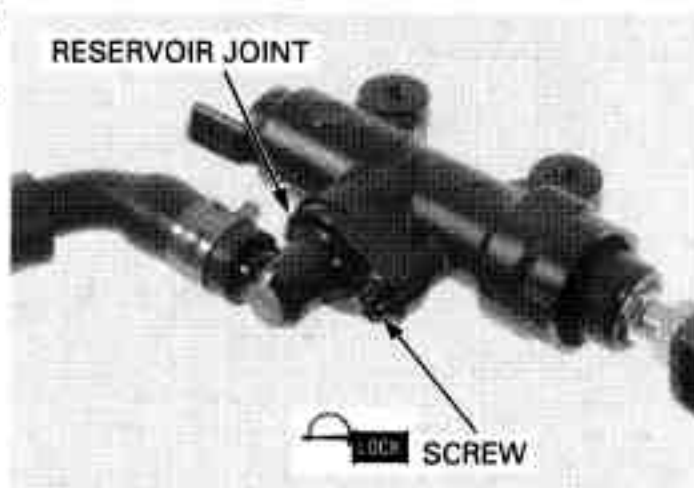

Install the reservoir cup to the reservoir hose.
Install the hose clamp securely.

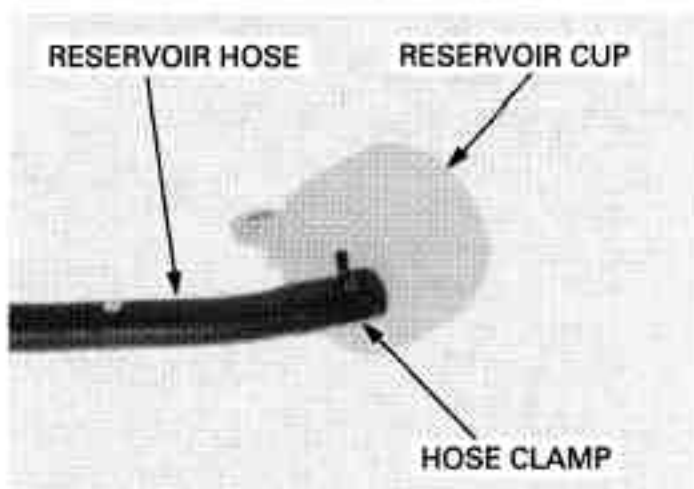

INSTALLATION

Place the rear master cylinder onto the right footpeg holder, then install the rear master cylinder mounting bolts.

Connect the brake pedal to the push rod lower joint. Install the joint pin and secure it with a new cotter pin.

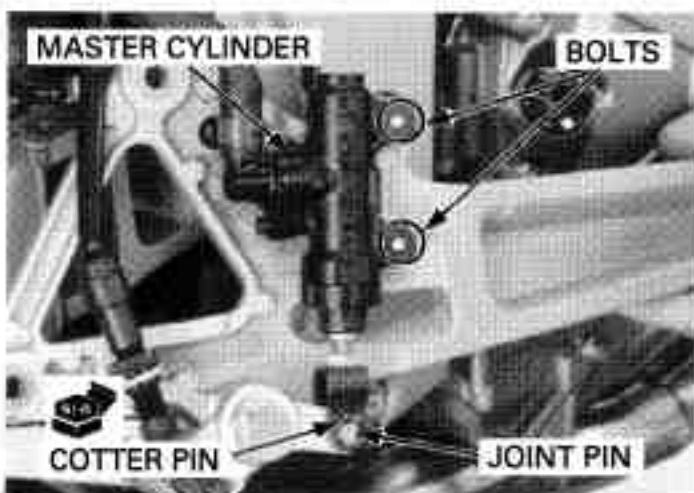

Install the right footpeg holder onto the frame, tighten the bolts to the specified torque.

TORQUE: 26 N·m (2.7 kgf·m, 20 lbf·ft)

Tighten the rear master cylinder mounting bolts to the specified torque.

TORQUE: 12 N·m (1.2 kgf·m, 9 lbf·ft)

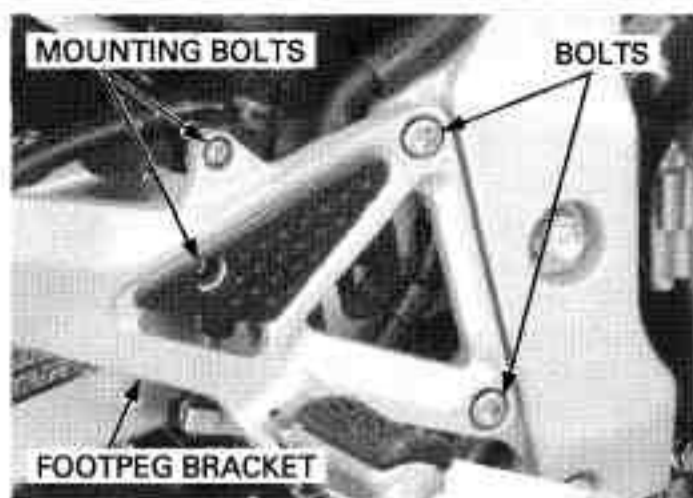

Install the wire band.
Install the reservoir hose to the clamp.

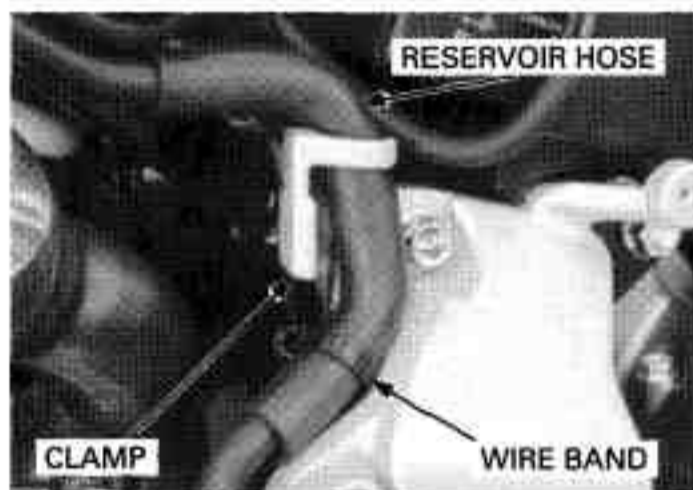

Install the brake hose with the oil bolt and new sealing washers.

Push the eyelet joint against the stopper, then tighten the oil bolt to the specified torque.

TORQUE: 34 N·m (3.5 kgf·m, 25 lbf·ft)



Install and tighten the brake reservoir mounting bolt securely.

Fill the reservoir to the upper level (page 16-7) and bleed the brake system (page 16-7).
Install the right side cover (page 3-4).

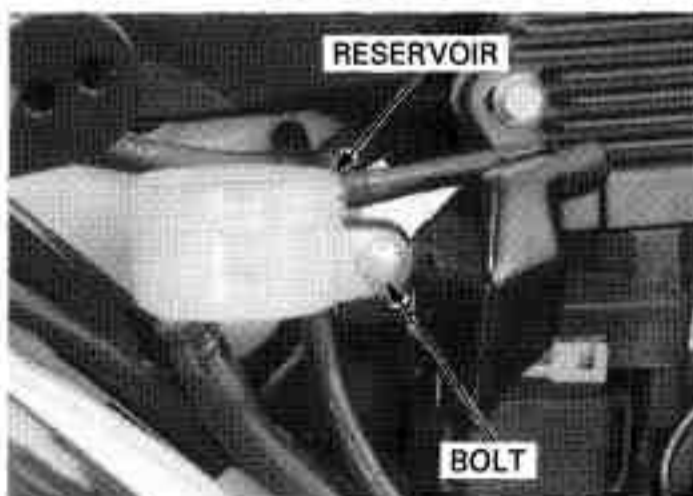

FRONT BRAKE CALIPER

REMOVAL

Drain the front brake hydraulic system (page 16-6).
Remove the brake pads (page 16-9).

Avoid spilling fluid on painted, plastic, or rubber parts. Place a rag over these parts whenever the system is serviced.

Remove the oil bolt, sealing washers and brake hose eyelet joint.

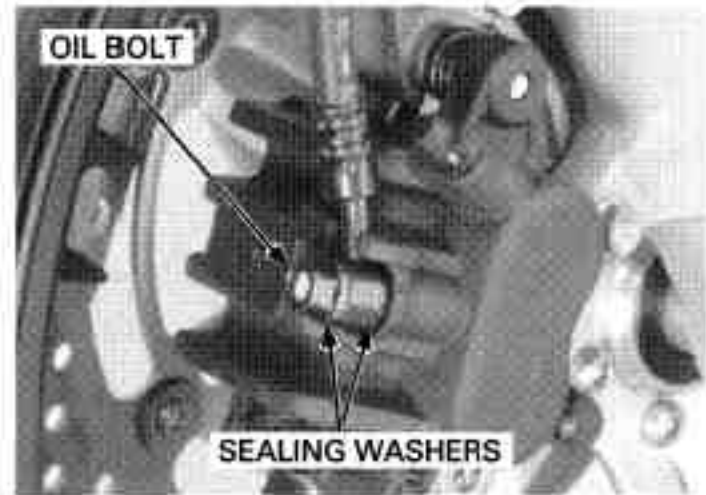

Remove the caliper mounting bolts and the front brake caliper.

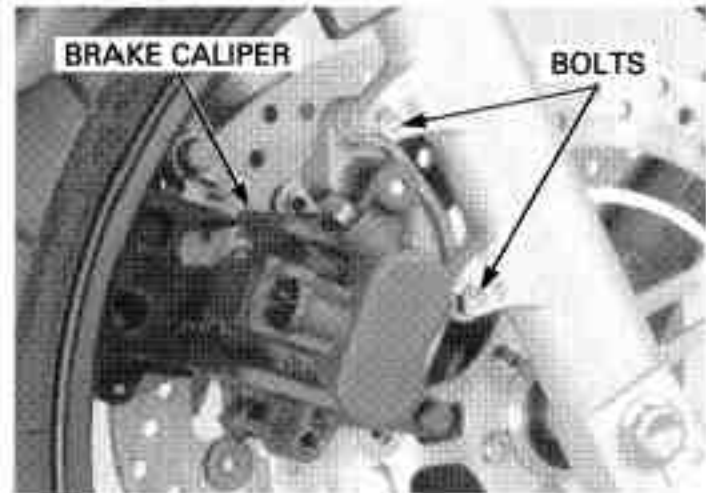

DISASSEMBLY

Remove the caliper bracket from the caliper body.

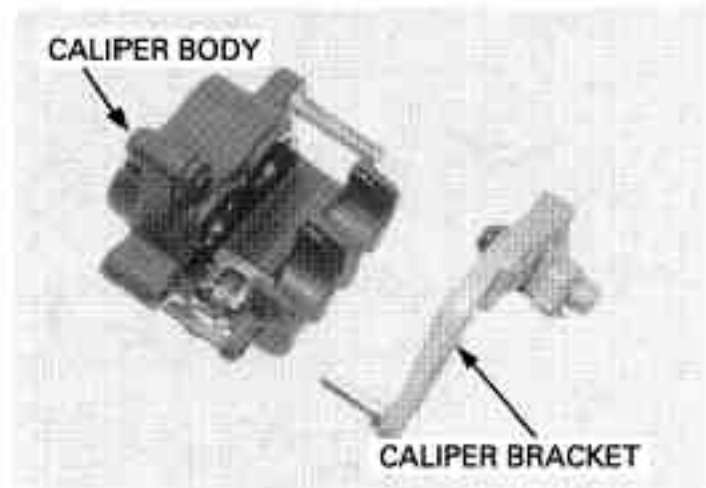

Remove the pad retainer and caliper pin boot from the caliper bracket.

If the bracket pin boot is hard or deteriorated, replace it with a new one.

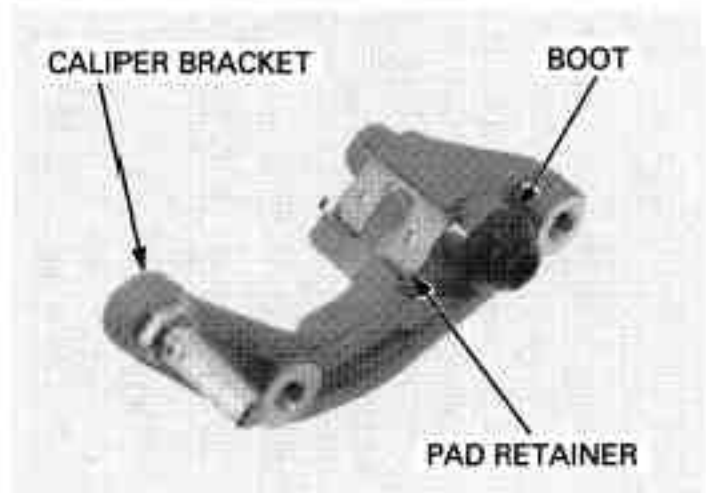

Remove the pad spring and bracket pin boot from the caliper body.

If the bracket pin boot is hard or deteriorated, replace it with a new one.

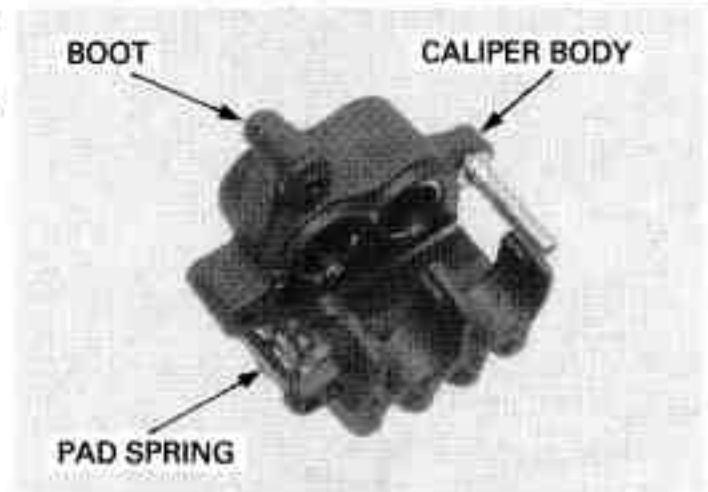

Place a shop towel over the pistons.

Do not use high pressure air or bring the nozzle too close to the inlet.

Position the caliper body with the pistons down and apply small squirts of air pressure to the fluid inlet to remove the pistons.

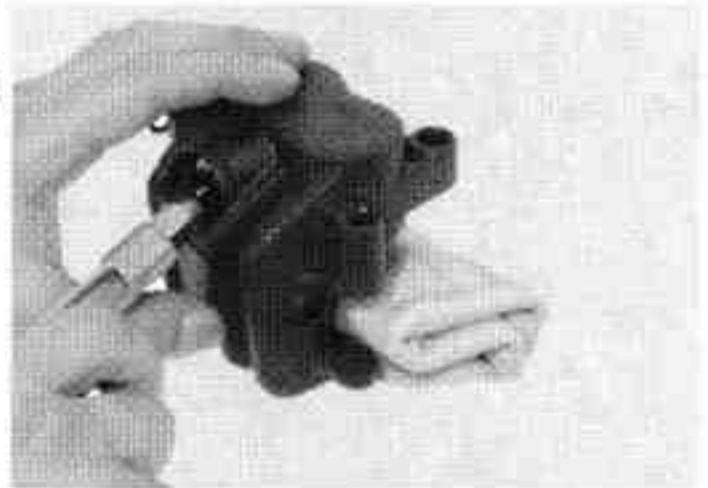

Be careful not to damage the piston sliding surface.

Push the dust seals and piston seals in and lift them out.

Clean the seal grooves with clean brake fluid.

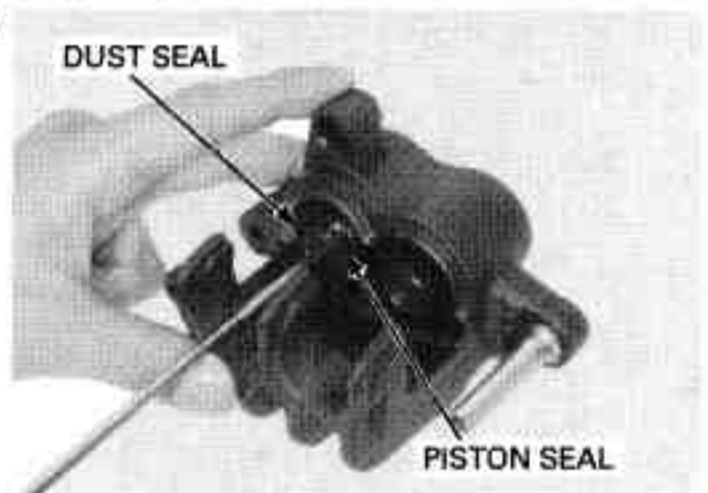

INSPECTION

Check the caliper cylinder for scoring or other damage.

Check the caliper pistons for scratches, scoring or other damage.

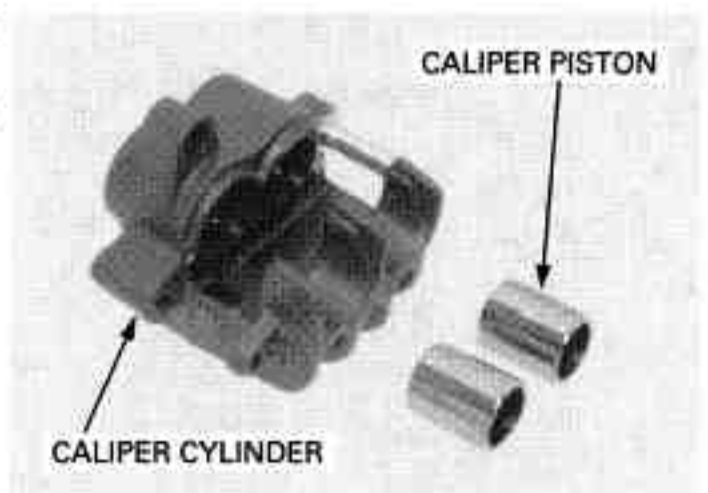

HYDRAULIC BRAKE

ASSEMBLY

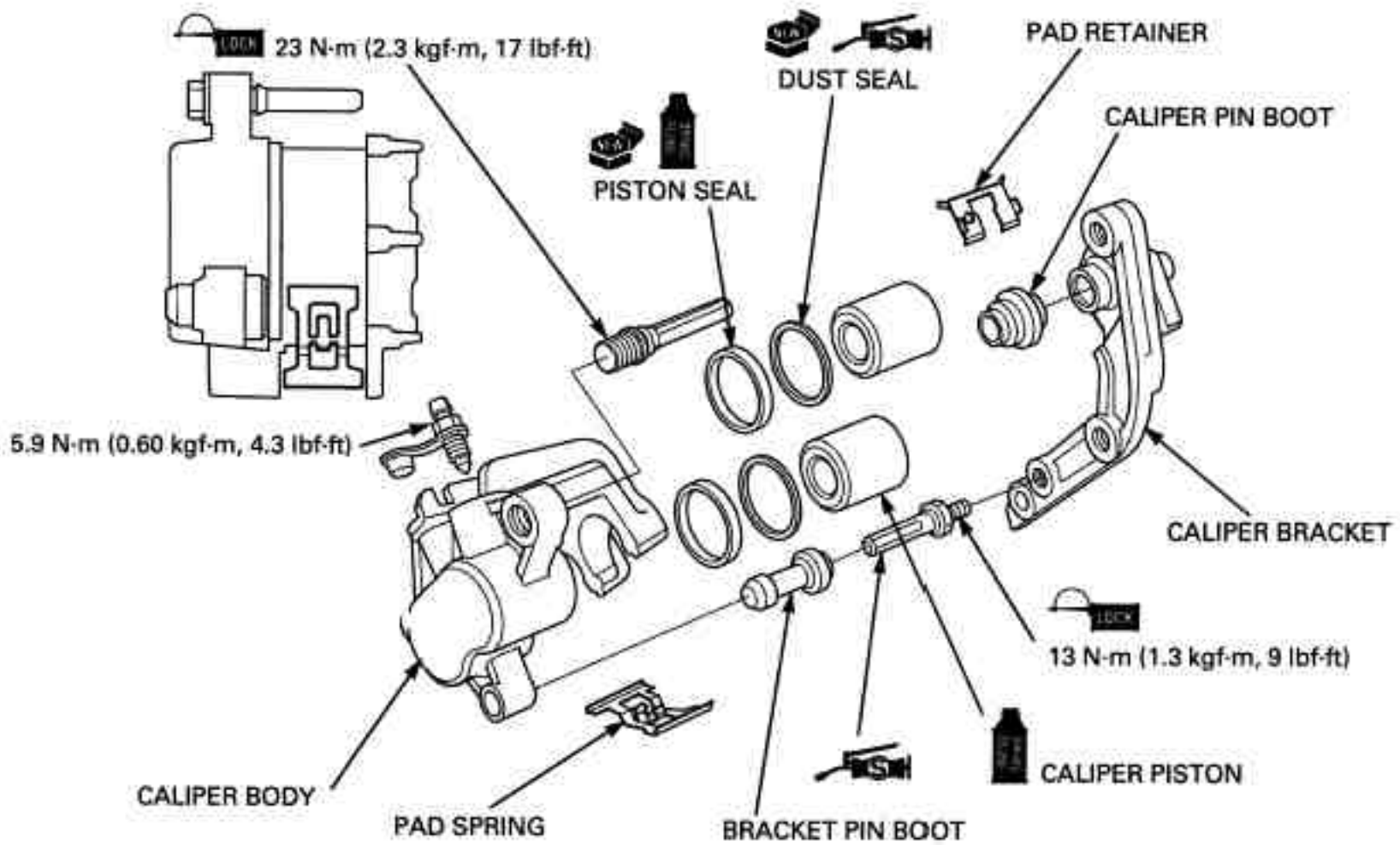

Coat the new piston seals with clean brake fluid.
Coat the new dust seals with silicone grease.
Coat the caliper pistons with clean brake fluid.



Install the piston and dust seal into the groove of the caliper body.

Install the caliper pistons into the caliper cylinder with their opening ends toward the pad.

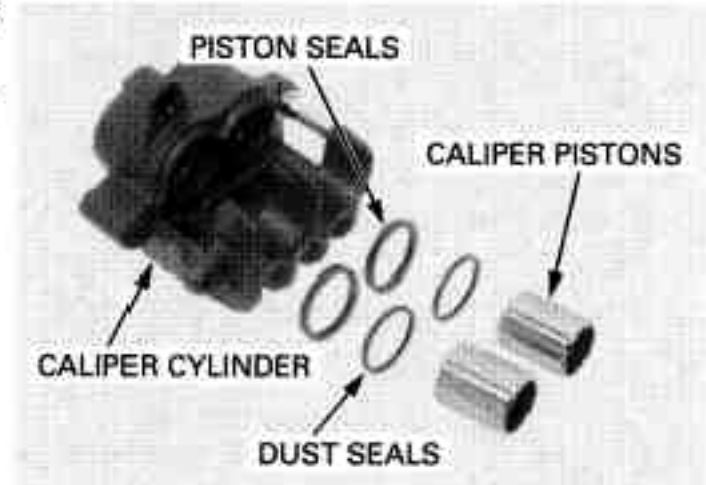

Note the installation direction of the pad spring.

Install the pad spring in the caliper body.

Install the bracket pin boot into the caliper body.

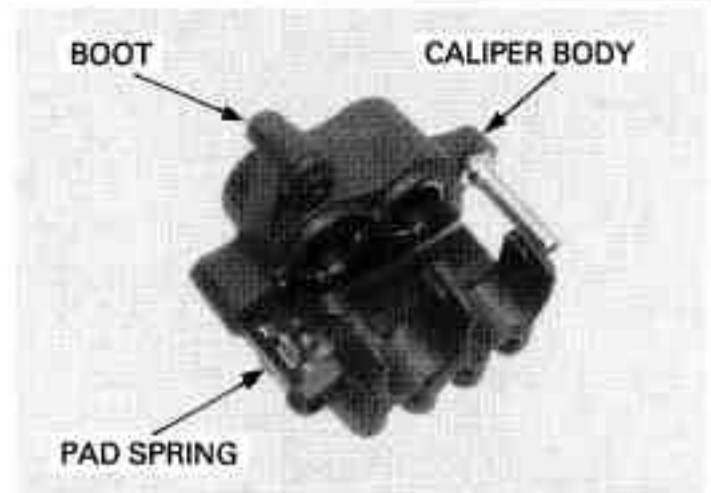

Install the brake pad retainer and caliper pin boot into the caliper bracket.

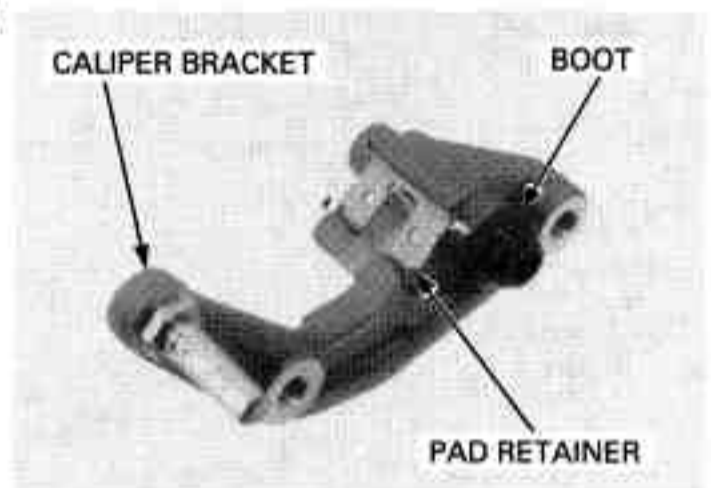

Apply silicone grease to the caliper and bracket pins and install the caliper bracket over the caliper body.

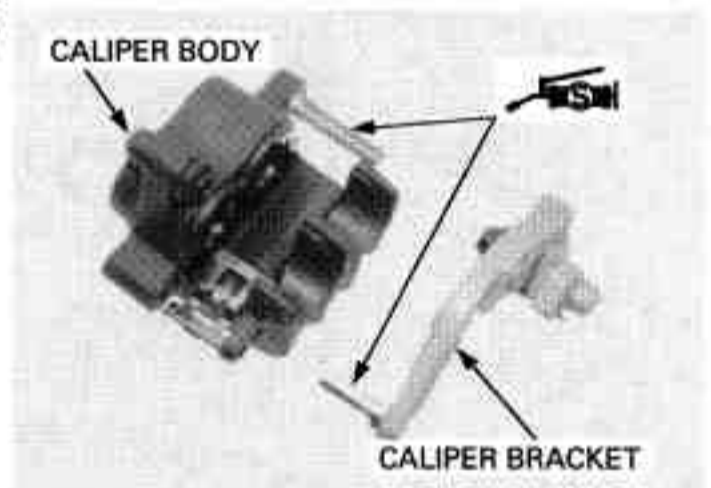

INSTALLATION

Install the brake caliper onto the fork leg.

Install and tighten the new brake caliper mounting bolts to the specified torque.

TORQUE: 30 N·m (3.1 kgf·m, 22 lbf·ft)

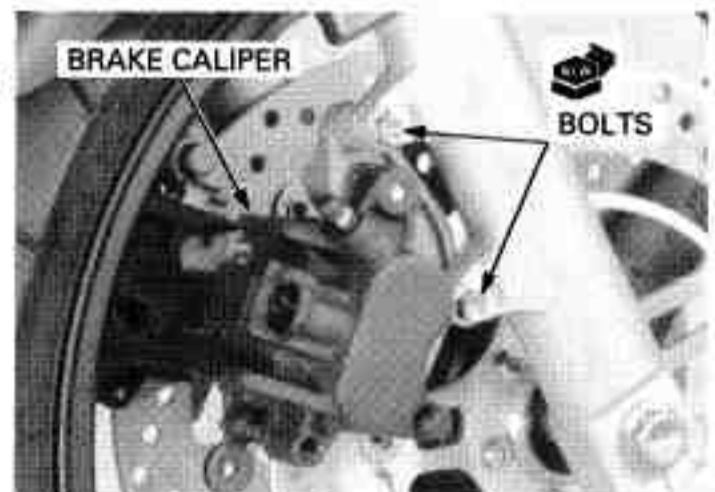

HYDRAULIC BRAKE

Install the brake hose eyelet to the caliper body with two new sealing washers and oil bolt.

Push the brake hose eyelet to the stopper on the caliper body, then tighten the oil bolt to the specified torque.

TORQUE: 34 N·m (3.5 kgf·m, 25 lbf·ft)

Install the front brake pads (page 16-9).
Fill and bleed the front brake hydraulic system (page 16-8).

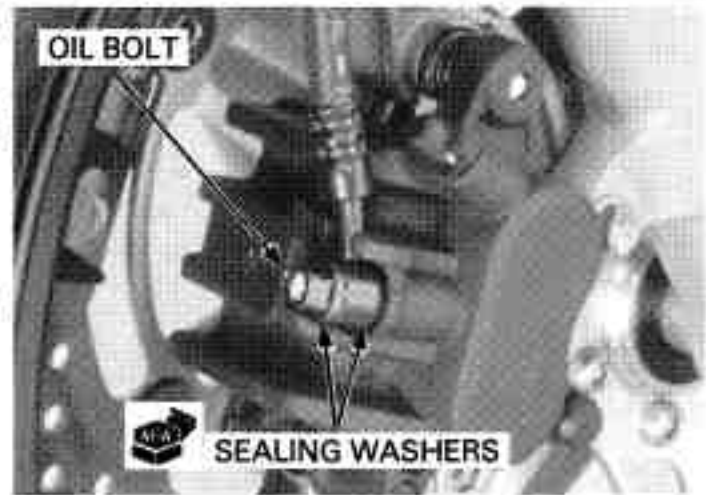

REAR BRAKE CALIPER

REMOVAL

Drain the rear brake hydraulic system (page 16-6).

Avoid spilling fluid on painted, plastic, or rubber parts. Place a rag over these parts whenever the system is serviced.

Remove the oil bolt, sealing washers and brake hose eyelet joint.

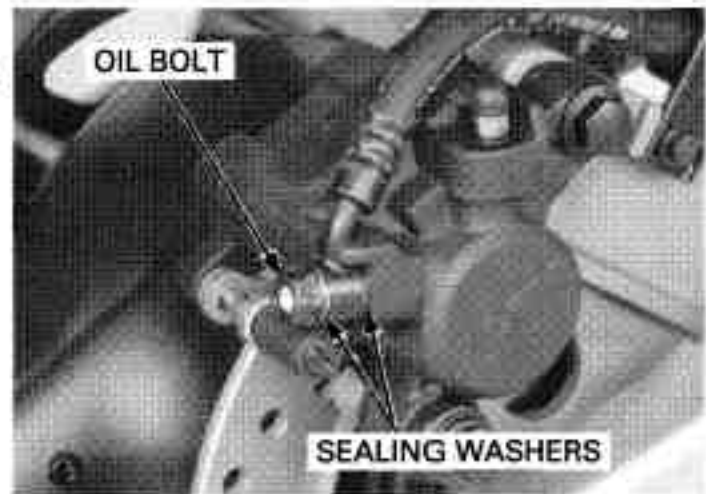

Remove the caliper sub slide pin and the brake pads (page 16-10).

Pivot the caliper up and remove it.

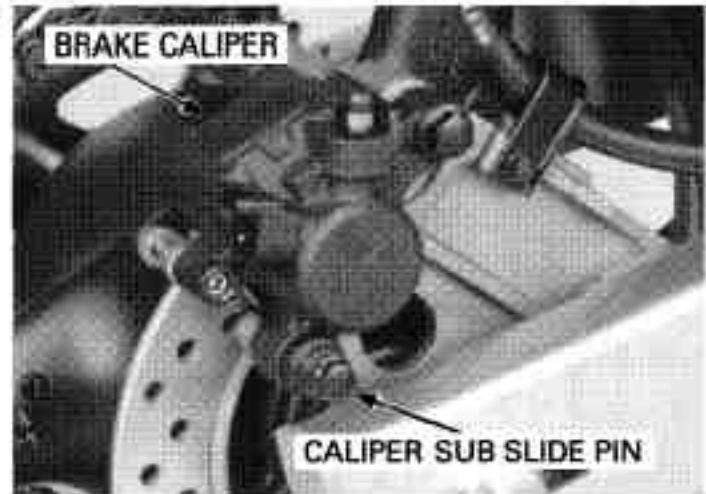

DISASSEMBLY

Remove the pad retainer and caliper main slide pin boot from the caliper bracket.

If the caliper main slide pin boot is hard or deteriorated, replace it with a new one.

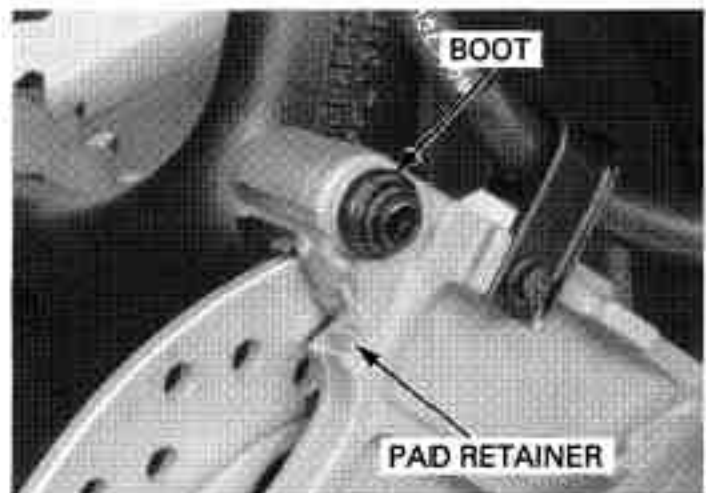

Remove the pad spring, collar and caliper sub slide pin boot from the caliper body.

If the caliper sub slide pin boot is hard or deteriorated, replace it with a new one.

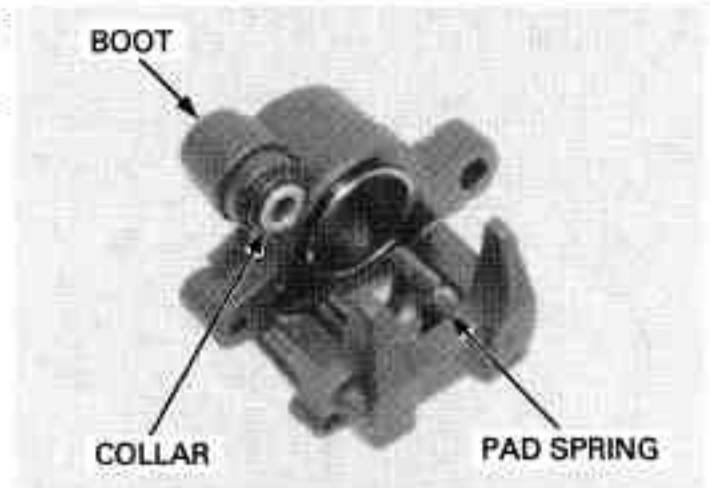

Place a shop towel over the pistons.

Do not use high pressure air or bring the nozzle too close to the inlet.

Position the caliper body with the pistons down and apply small squirts of air pressure to the fluid inlet to remove the pistons.



Be careful not to damage the piston sliding surface.

Push the dust seal and piston seal in and lift them out.
Clean the seal grooves with clean brake fluid.

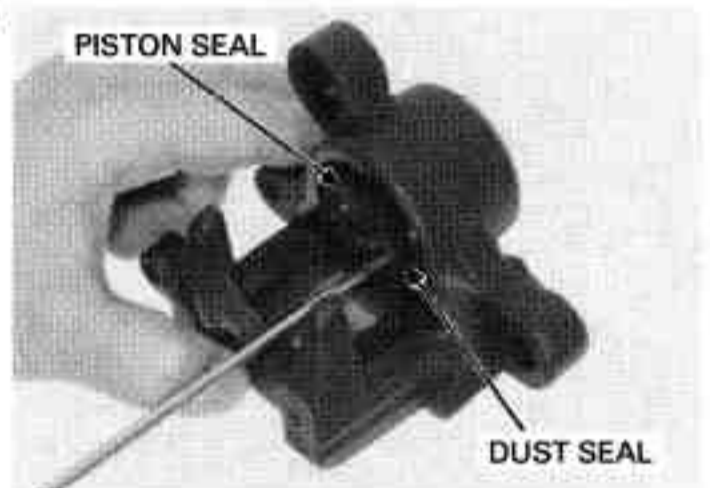

INSPECTION

Check the caliper cylinder for scoring or other damage.

Check the caliper pistons for scratches, scoring or other damage.

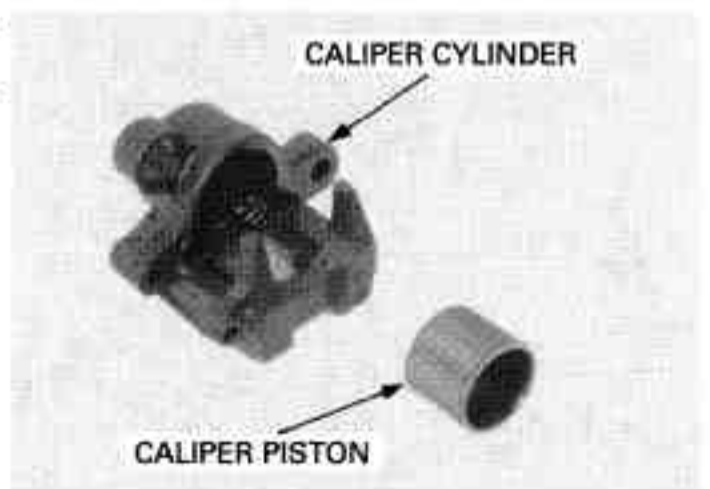

HYDRAULIC BRAKE

ASSEMBLY

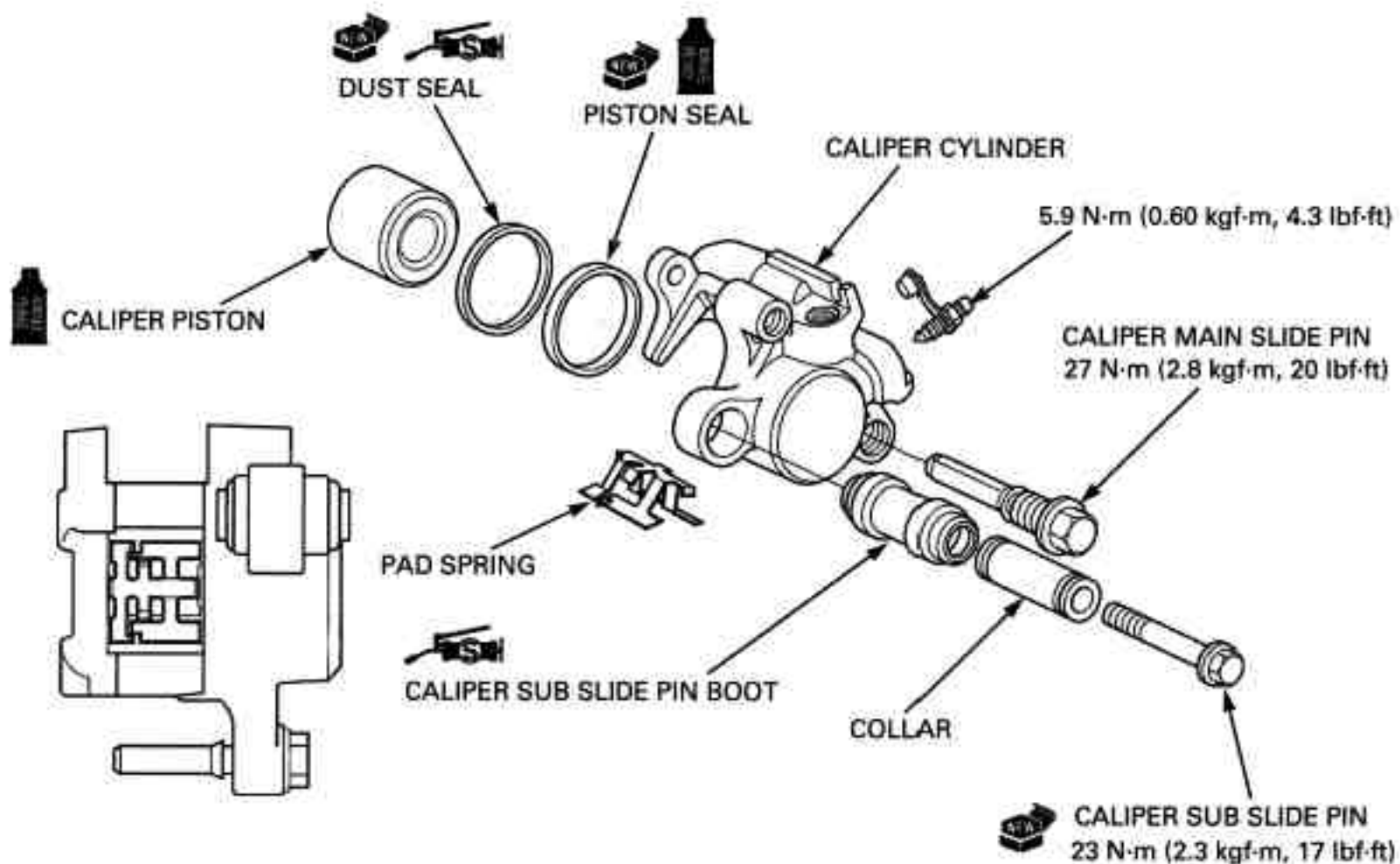

Coat a new piston seal with clean brake fluid.
Coat a new dust seal with silicone grease.
Coat the caliper piston with clean brake fluid.

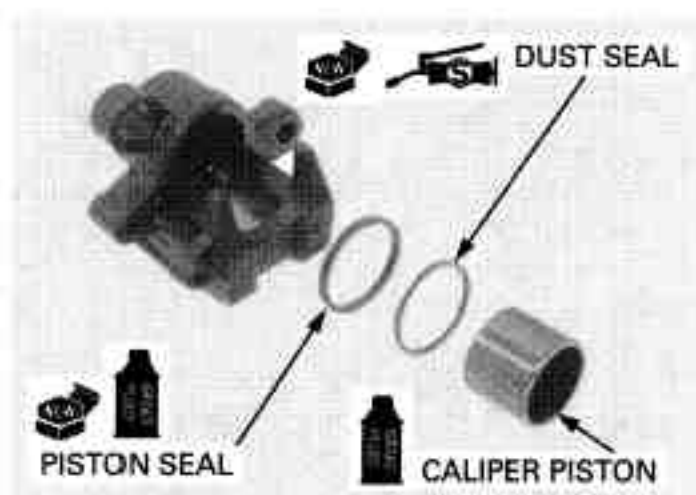

Install the piston seal and dust seal into the groove of the caliper body.

Install the caliper piston into the caliper cylinder with its opening end toward the pad.

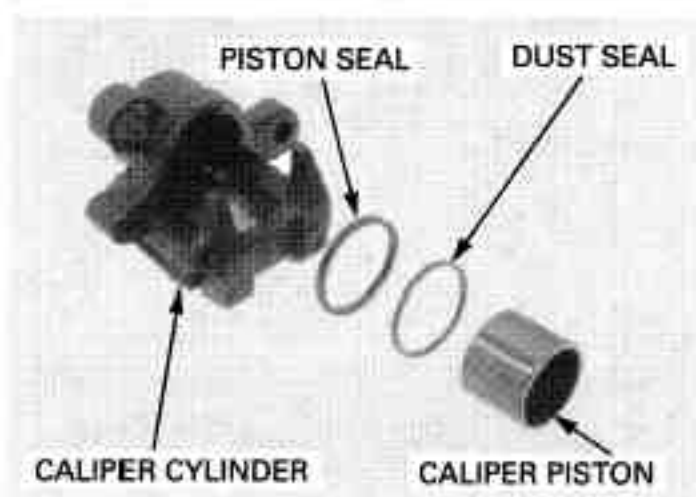

Install the pad spring into the caliper body.

Apply silicone grease to the inside of the caliper sub slide pin boot.

Install the caliper sub slide pin boot and collar into the caliper body.

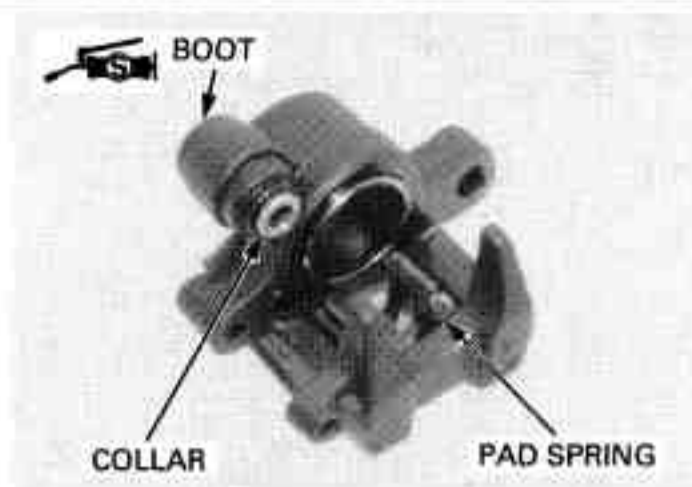

Install the pad retainer and caliper main slide pin boot into the caliper bracket.

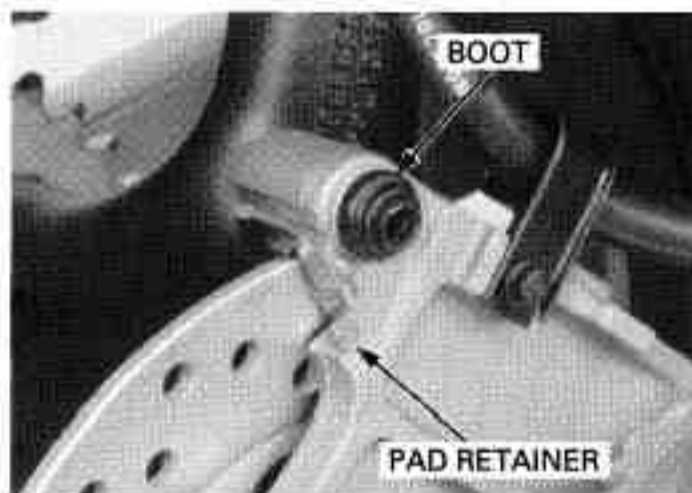

INSTALLATION

Apply silicone grease to the caliper main slide pin and install the caliper onto the bracket.

Install the brake pads (page 16-10).

Install and tighten the new caliper sub slide pin to the specified torque.

TORQUE: 23 N·m (2.3 kgf·m, 17 lbf·ft)

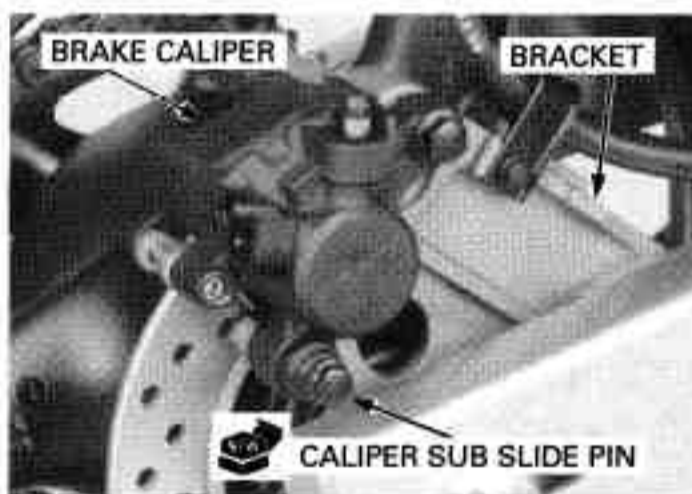

Install the brake hose eyelet to the caliper body with two new sealing washers and oil bolt.

Push the brake hose eyelet to the stopper on the caliper, then tighten the oil bolt to the specified torque.

TORQUE: 34 N·m (3.5 kgf·m, 25 lbf·ft)

Fill and bleed the rear brake hydraulic system (page 16-6).



BRAKE PEDAL

REMOVAL

Remove the bolts and right footpeg holder assembly from the frame.

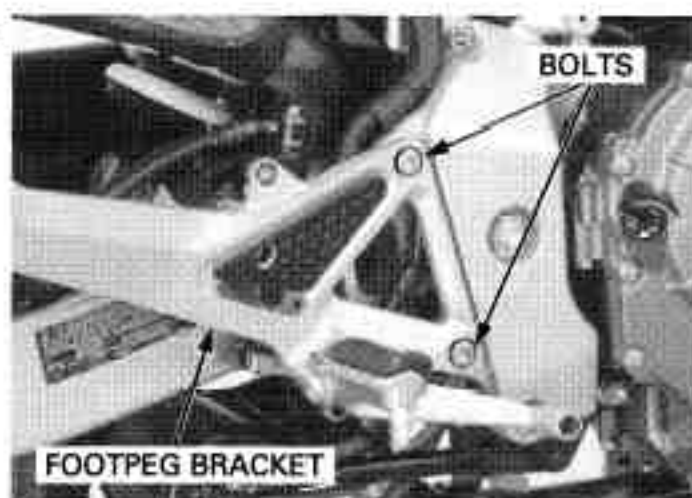

Remove and discard the brake pedal joint cotter pin. Remove the joint pin.

Unhook the return spring and remove the brake light switch from the foot peg holder. Unhook the brake pedal return spring.

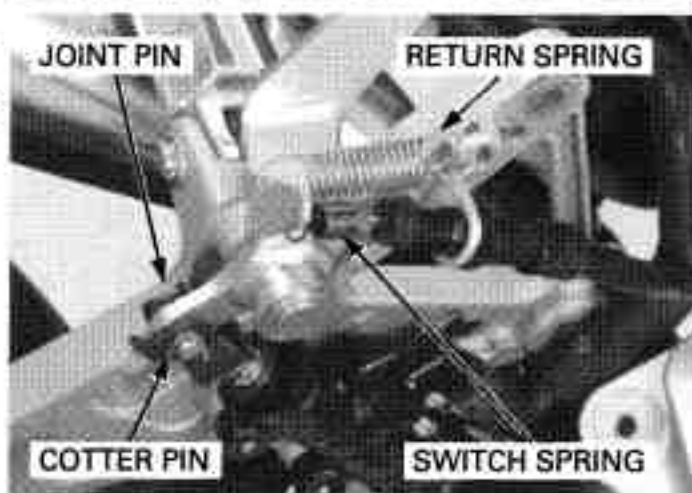

Remove the snap ring and thrust washer. Remove the brake pedal from the pivot.



INSTALLATION

Apply grease to the sliding surface of the brake pedal and footpeg.

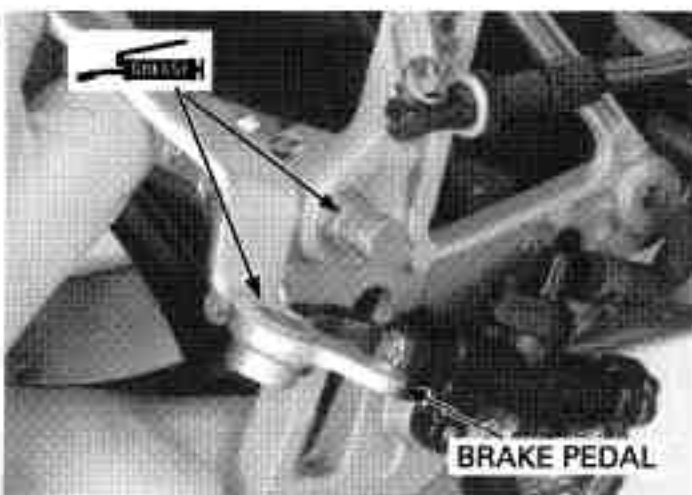

Install the brake pedal and thrust washer to the pedal pivot.
Secure the pedal pivot with a snap ring.



Hook the brake pedal return spring.
Install the brake light switch and hook the switch spring.
Connect the brake pedal to the push rod lower joint.
Install the joint pin and secure it with a new cotter pin.

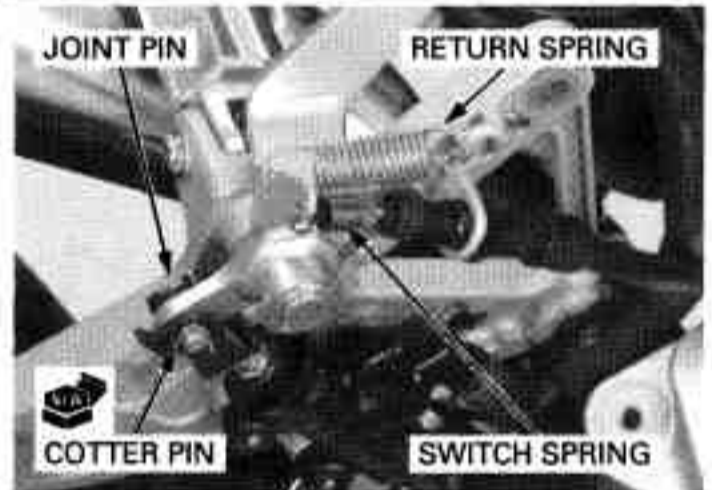

Install the right footpeg holder assembly onto the frame.
Install and tighten the right footpeg holder bolts to the specified torque.

TORQUE: 26 N·m (2.7 kgf·m, 20 lbf·ft)

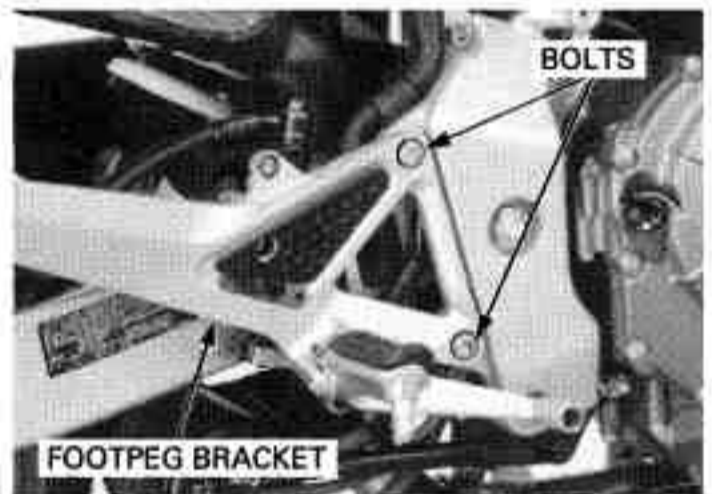

17. BATTERY/CHARGING SYSTEM

SYSTEM DIAGRAM.....	17-2	CHARGING SYSTEM INSPECTION.....	17-7
SERVICE INFORMATION.....	17-3	ALTERNATOR CHARGING COIL.....	17-8
TROUBLESHOOTING.....	17-5	REGULATOR/RECTIFIER.....	17-9
BATTERY.....	17-6		

BATTERY/CHARGING SYSTEM

SYSTEM DIAGRAM

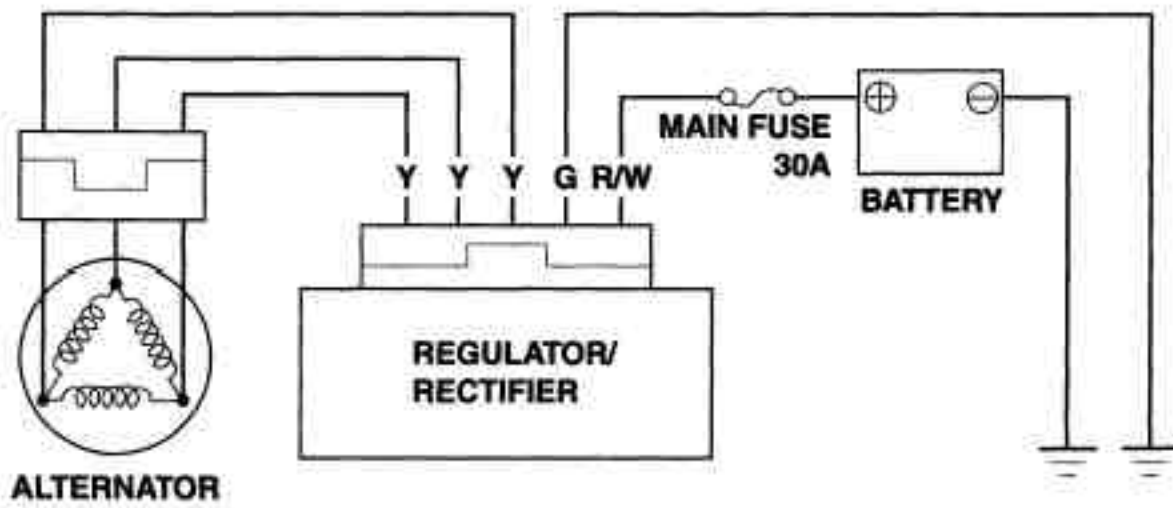
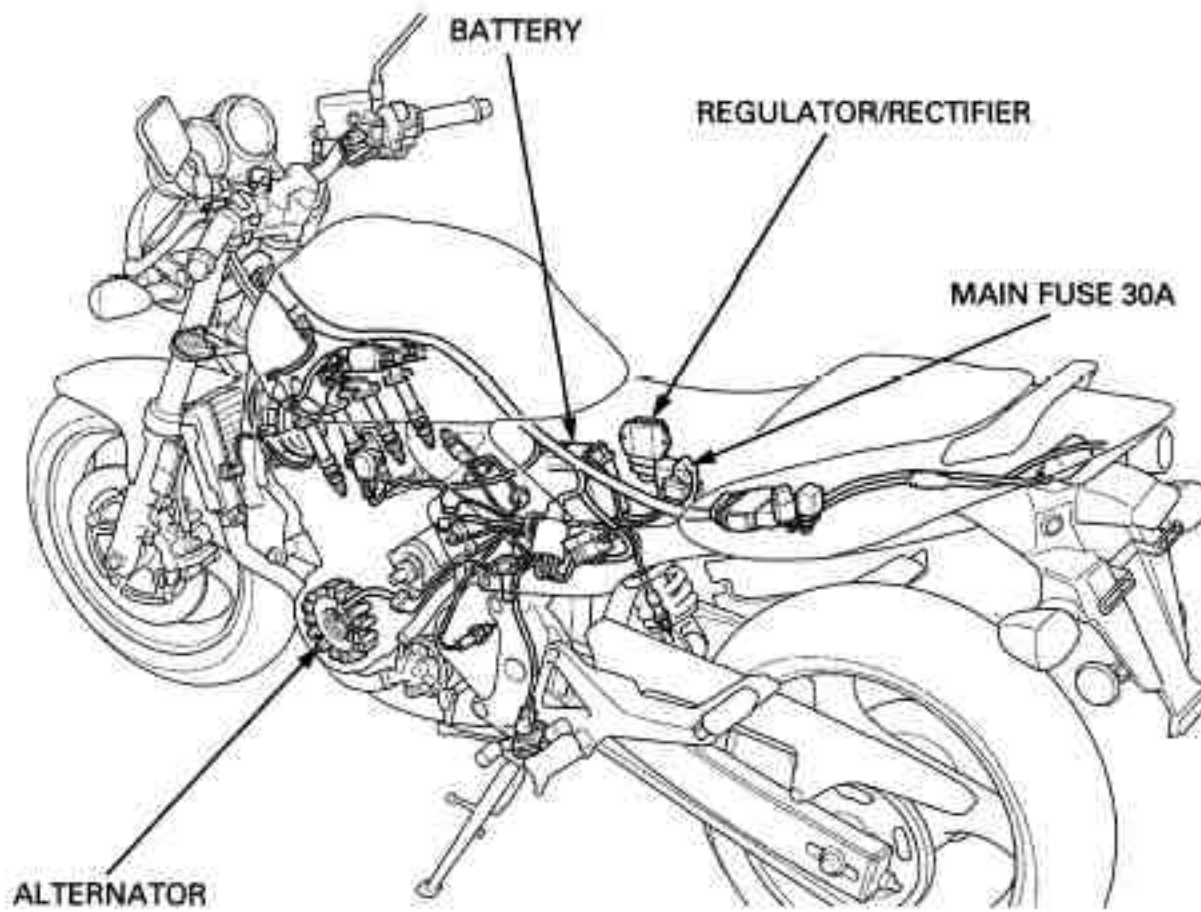

Y.....YELLOW
G.....GREEN
R.....RED
W.....WHITE

SERVICE INFORMATION

GENERAL

⚠ WARNING

- The battery gives off explosive gases; keep sparks, flames and cigarettes away. Provide adequate ventilation when charging.
- The battery contains sulfuric acid (electrolyte). Contact with skin or eyes may cause severe burns. Wear protective clothing and a face shield.
 - If electrolyte gets on your skin, flush with water.
 - If electrolyte gets in your eyes, flush with water for at least 15 minutes and call a physician immediately.
- Electrolyte is poisonous.
 - If swallowed, drink large quantities of water or milk and call your local Poison Control Center or a call a physician immediately.

NOTICE

- *Always turn OFF the ignition switch before disconnecting any electrical component.*
- *Some electrical components may be damaged if terminals or connectors are connected or disconnected while the ignition switch is ON and current is present.*
- For extended storage, remove the battery, give it a full charge, and store it in a cool, dry space. For maximum service life, charge the stored battery every two weeks.
- For a battery remaining in a stored motorcycle, disconnect the negative battery cable from the battery terminal.
- The maintenance free battery must be replaced when it reaches the end of its service life.
- The battery can be damaged or overcharged or undercharged, or of left to discharge for long period. These same conditions contribute to shortening the "life span" of the battery. Even under normal use, the performance of the battery deteriorates after 2-3 years.
- Battery voltage may recover after battery charging, but under heavy load, battery voltage will drop quickly and eventually die out. For this reason, the charging system is often suspected as the problem. Battery overcharge often results from problems in the battery itself, which may appear to be an overcharging symptom. If one of the battery cells is shorted and battery voltage does not increase, the regulator/rectifier supplies excess voltage to the battery. Under these conditions, the electrolyte level goes down quickly.
- Before troubleshooting the charging system, check for proper use and maintenance of the battery. Check if the battery is frequently under heavy load, such as having the headlight and taillight ON for long periods of time without riding the motorcycle.
- The battery will self-discharge when the motorcycle is not in use. For this reason, charge the battery every two weeks to prevent sulfation from occurring.
- When checking the charging system, always follow the steps in the troubleshooting flow chart page 17-5.
- For battery charging, do not exceed the charging current and time specified on the battery. Use of excessive current or charging time may damage the battery.
- If the battery terminals were disconnected, the data showing the possible travel distance will be reset. After the connection of battery terminals, the data will be indicated in quotation marks ("—").
- For alternator removal and disassembly (page 11-4).

BATTERY TESTING

Refer to the instruction of the Operation Manual for the recommended battery tester. The recommended battery tester puts a "load" on the battery so that the actual battery condition of the load can be measured.



Recommended Battery Tester: BM-210-AH, BM-210 or BATTERY MATE (MTP08-0192, U.S.A. only) or equivalent

BATTERY/CHARGING SYSTEM

SPECIFICATIONS

ITEM		SPECIFICATIONS	
Battery	Capacity	12V - 6 Ah	
	Current leakage	1.2 mA max.	
	Voltage (20°C/68°F)	Fully charged	13.0 - 13.2 V
		Needs charging	Below 12.3 V
Charging current	Normal	0.9 A/5 - 10 h	
	Quick	4.0 A/1.0 h	
Alternator	Capacity	0.34 kW/5,000 rpm	
	Charging coil resistance (20°C/68°F)	0.1 - 1.0 Ω	

TOOLS

<p>Battery tester BM-210-AH (U.S.A. only)</p> 	<p>Christie battery charger MC1012/2 (U.S.A. only)</p> 	<p>BatteryMate tester/charger MTP08-0192 (U.S.A. only)</p> 
--	--	---

TROUBLESHOOTING

BATTERY IS DAMAGED OR WEAK

1. BATTERY TEST

Remove the battery (page 17-6).

Check the battery condition using the recommended battery tester.

RECOMMENDED BATTERY TESTER: BM-210-AH, BM-210, or BATTERY MATE (MTP08-0192, U.S.A. only) or equivalent

Is the battery in good condition?

No – Faulty battery

YES – GO TO STEP 2.

2. CURRENT LEAKAGE TEST

Install the battery (page 17-6).

Check the battery current leakage test (Leak test; page 17-7).

Is the current leakage below 2.0mA?

YES – GO TO STEP 4.

NO – GO TO STEP 3.

3. CURRENT LEAKAGE TEST WITHOUT REGULATOR/RECTIFIER CONNECTOR

Disconnect the regulator/rectifier connector and recheck the battery current leakage.

Is the current leakage below 2.0mA?

YES – Faulty regulator/rectifier

NO – • Shorted wire harness
• Faulty ignition switch

4. ALTERNATOR CHARGING COIL INSPECTION

Check the alternator charging coil (page 17-8).

Is the alternator charging coil resistance within 0.1 – 1.0 Ω (20°C/68°F)?

No – Faulty charging coil

YES – GO TO STEP 5.

5. CHARGING VOLTAGE INSPECTION

Measure and record the battery voltage using a digital multimeter (page 17-6).

Start the engine.

Measure the charging voltage (page 17-8).

Compare the measurement to result of the following calculation.

STANDARD:

Measured battery Voltage < Measured charging voltage < 15.5 V

Is the measured charging voltage within the standard voltage?

YES – Faulty battery

NO – GO TO STEP 6.

6. REGULATOR/RECTIFIER SYSTEM INSPECTION

Check the voltage and resistance at the regulator/rectifier connector (page 17-9).

Are the results of checked voltage and resistance correct?

YES – Faulty regulator/rectifier

NO – • Open circuit in related wire
• Loose or poor contacts of related terminal
• Shorted wire harness

BATTERY

REMOVAL/INSTALLATION

Always turn the ignition switch OFF before removing the battery.

Remove the right side cover (page 3-4).

Remove the terminal screw, then disconnect the negative cable from the battery negative terminal.

Remove the holder band and pull the battery out.

Remove the positive terminal cover.

Remove the terminal screw, then disconnect the positive cable from the battery positive terminal.

Remove the battery.

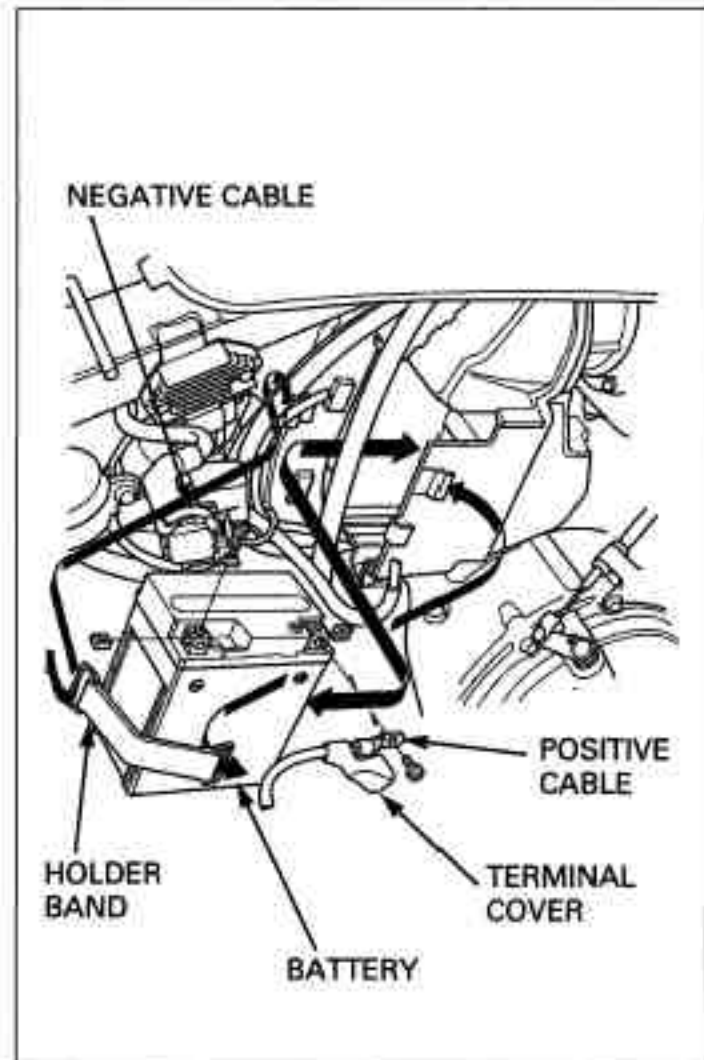

Connect the positive terminal first and then the negative cable.

Installation is in the reverse order of removal.

After installing the battery, coat the terminals with clean grease.

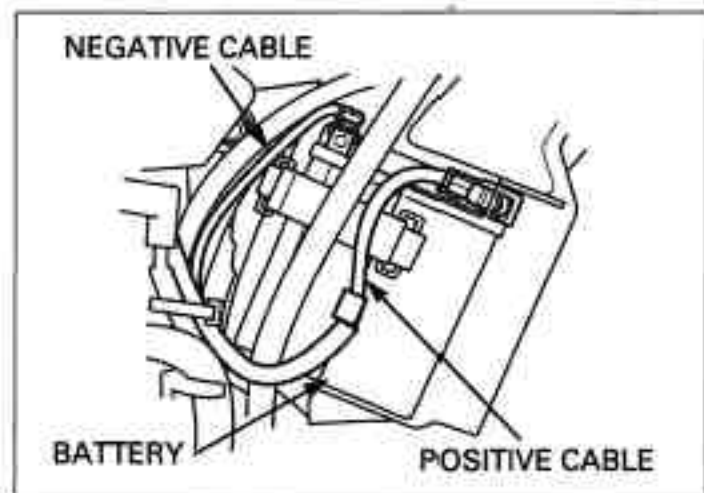

VOLTAGE INSPECTION

Measure the battery voltage using a digital multimeter.

VOLTAGE:

Fully charged: 13.0 - 13.2V

Under charged: Below 12.3V

TOOL:

Digital multimeter Commercially available in U.S.A.

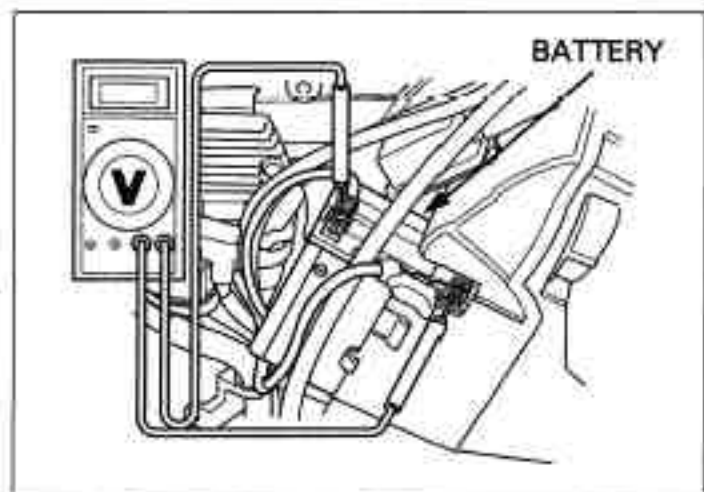

BATTERY TESTING

Refer to the instructions that are appropriate to the battery testing equipment available to you.

TOOL:

Battery tester BM-210-AH, BM-210 or
BATTERY MATE (MTP08-0192, U.S.A.
only) or equivalent

BATTERY CHARGING (U.S.A. only)

Refer to the instructions that are appropriate to the battery charging equipment available to you.

TOOL:

Battery charger Christie battery charger (MC1012/2,
U.S.A. only) or
BATTERY MATE (MTP08-0192, U.S.A.
only) or equivalent

CHARGING SYSTEM INSPECTION**CURRENT LEAKAGE INSPECTION**

Turn the ignition switch off and disconnect the negative battery cable from the battery.

Connect the ammeter (+) probe to the ground cable and the ammeter (-) probe to the battery (-) terminal.

With the ignition switch off, check for current leakage.

- When measuring current using a tester, set it to a high range, and then bring the range down to an appropriate level. Current flow higher than the range selected may blow out the fuse in the tester.
- While measuring current, do not turn the ignition on. A sudden surge of current may blow out the fuse in the tester.

SPECIFIED CURRENT LEAKAGE: 1.2 mA max.

If current leakage exceeds the specified value, a shorted circuit is likely.

Locate the short by disconnecting connections one by one and measuring the current.

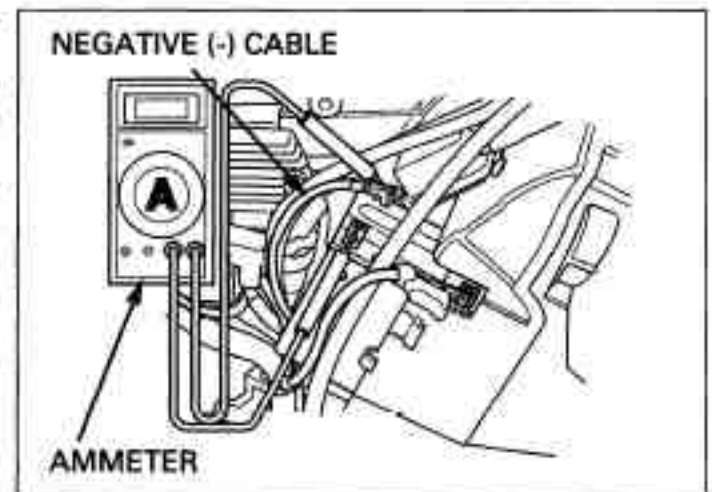

BATTERY/CHARGING SYSTEM

CHARGING VOLTAGE INSPECTION

Be sure the battery is in good condition before performing this test.

Warm up the engine to normal operating temperature.

Stop the engine, and connect the multimeter as shown.

NOTICE

Do not disconnect the battery or any cable in the charging system without first switching off the ignition switch. Failure to follow this precaution can damage the tester or electrical components.

- To prevent a short, make absolutely certain which are the positive and negative terminals or cable.

Restart the engine.

With the headlight on Hi beam, measure the voltage on the multimeter when the engine runs at 5,000 rpm.

Standard:

Measured BV < Measured CV < 15.5 V at 5,000 rpm

- BV: Battery Voltage (page 17-6)
- CV: Charging Voltage (page 17-7)

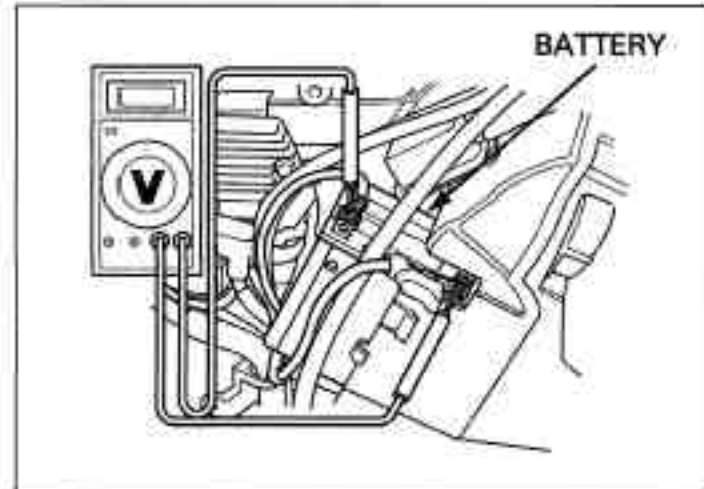

ALTERNATOR CHARGING COIL

It is not necessary to remove the stator coil to make this test.

INSPECTION

Remove the left side cover (page 3-4).

Disconnect the alternator 3P (Natural) connector.

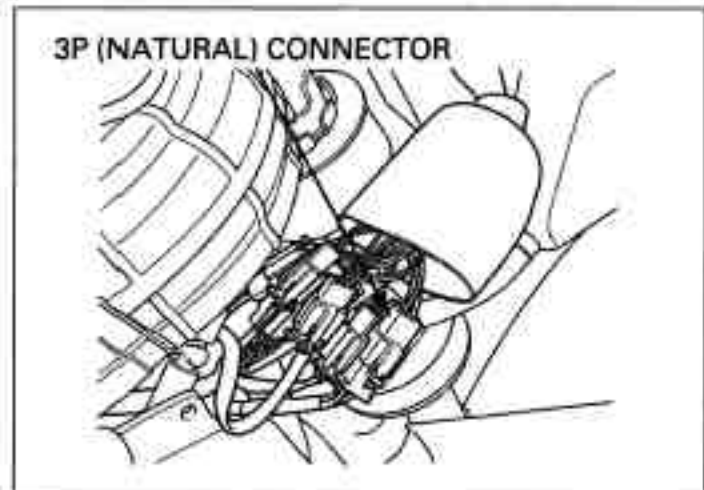

Check the resistance between all three Yellow terminals.

STANDARD: 0.1 – 1.0 Ω (at 20°C/68°F)

Check for continuity between all three Yellow terminals and Ground.

There should be no continuity.

If readings are far beyond the standard, or if any wire has continuity to ground, replace the alternator stator (page 11-5).

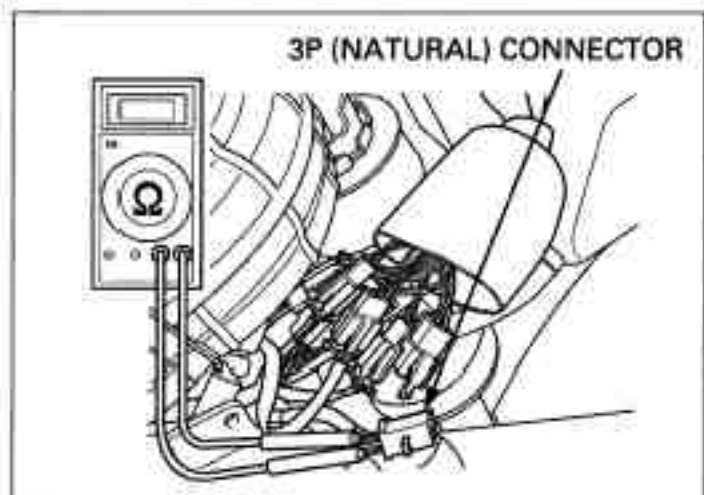

REGULATOR/RECTIFIER

SYSTEM INSPECTION

Remove the fuel tank (page 3-6).

Disconnect the regulator/rectifier 5P connector, and check it for loose contact or corroded terminals.

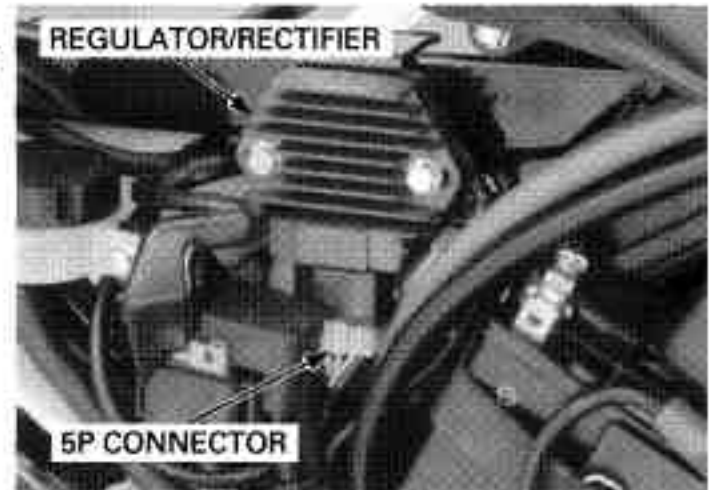

If the regulated voltage reading (page 17-8) is out of the specification, measure the voltage between connector terminals (wire harness side) as follows:

Item	Terminal	Specification
Battery charging line	Red/White (+) and ground (-)	Battery voltage should register
Charging coil line	Yellow and Yellow	0.1 – 1.0 Ω at (20°C/68°F)
Ground line	Green and ground	Continuity should exist

If all components of the charging system are normal and there are no loose connections at the regulator/rectifier connectors, replace the regulator/rectifier unit.

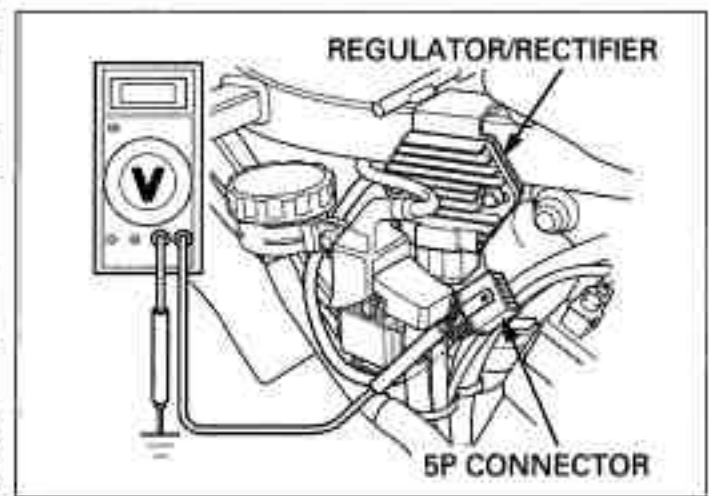

REMOVAL/INSTALLATION

Remove the fuel tank (page 3-6).

Disconnect the regulator/rectifier 5P connector. Remove the regulator/rectifier unit mounting bolts, regulator/rectifier and plate.

Install the regulator/rectifier unit in the reverse order of removal.

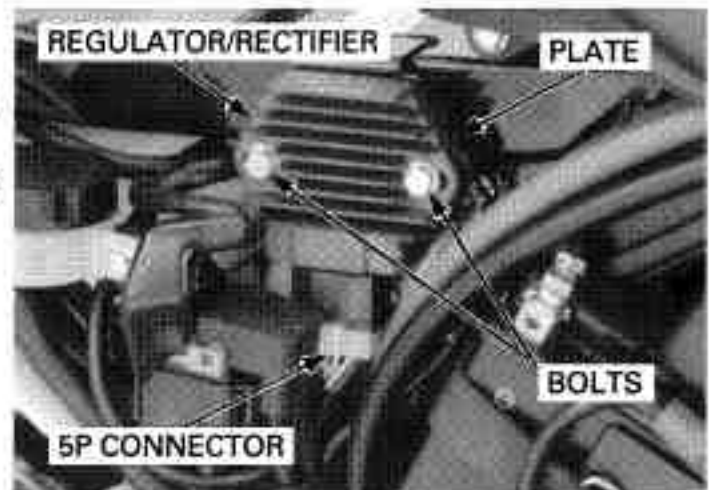

18. IGNITION SYSTEM

SYSTEM DIAGRAM	18-2	IGNITION COIL	18-10
SERVICE INFORMATION	18-3	TP SENSOR	18-10
TROUBLESHOOTING	18-4	IGNITION CONTROL MODULE (ICM)	18-12
IGNITION SYSTEM INSPECTION	18-5	IGNITION TIMING	18-12
IGNITION PULSE GENERATOR	18-7		

IGNITION SYSTEM

SYSTEM DIAGRAM

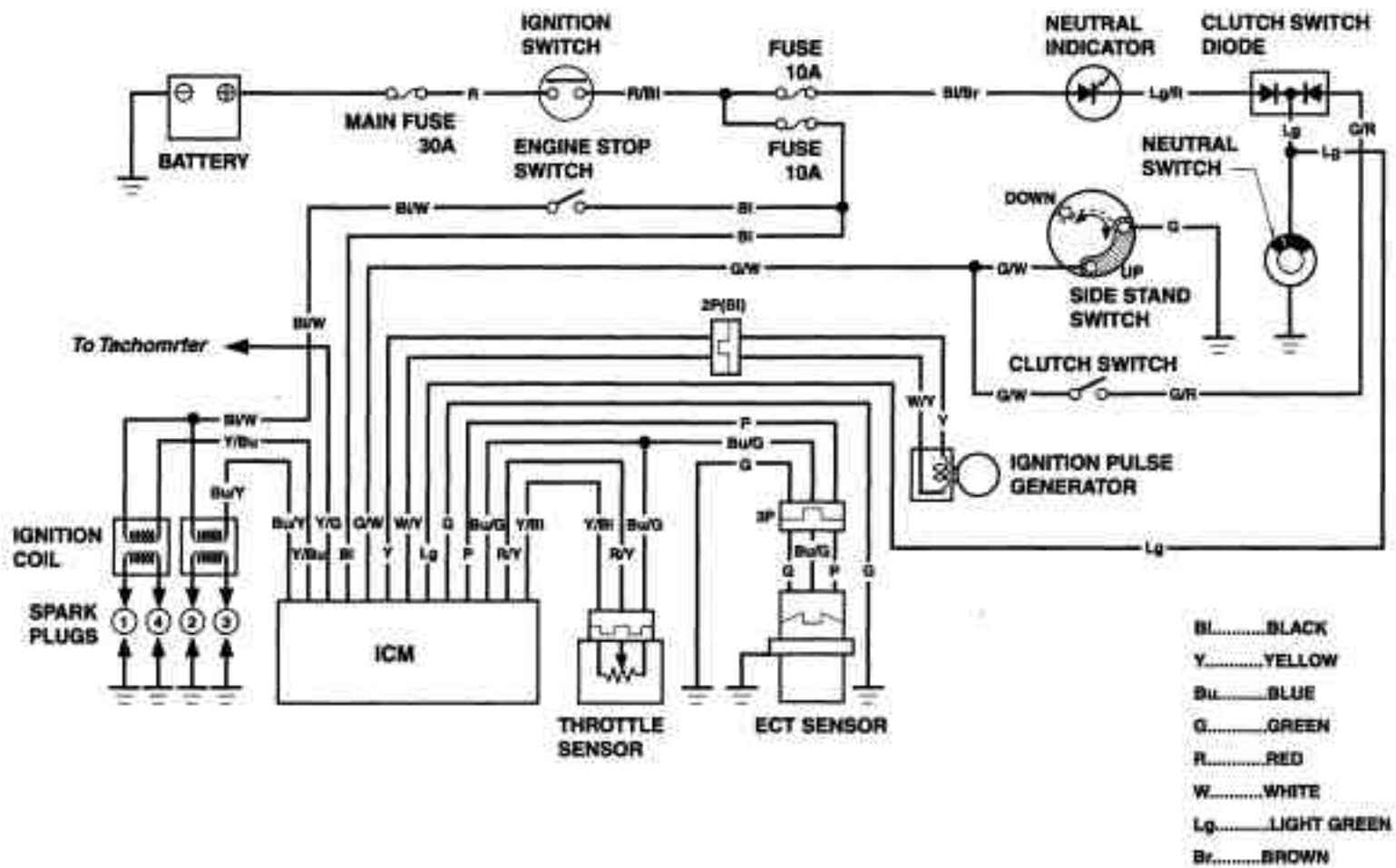
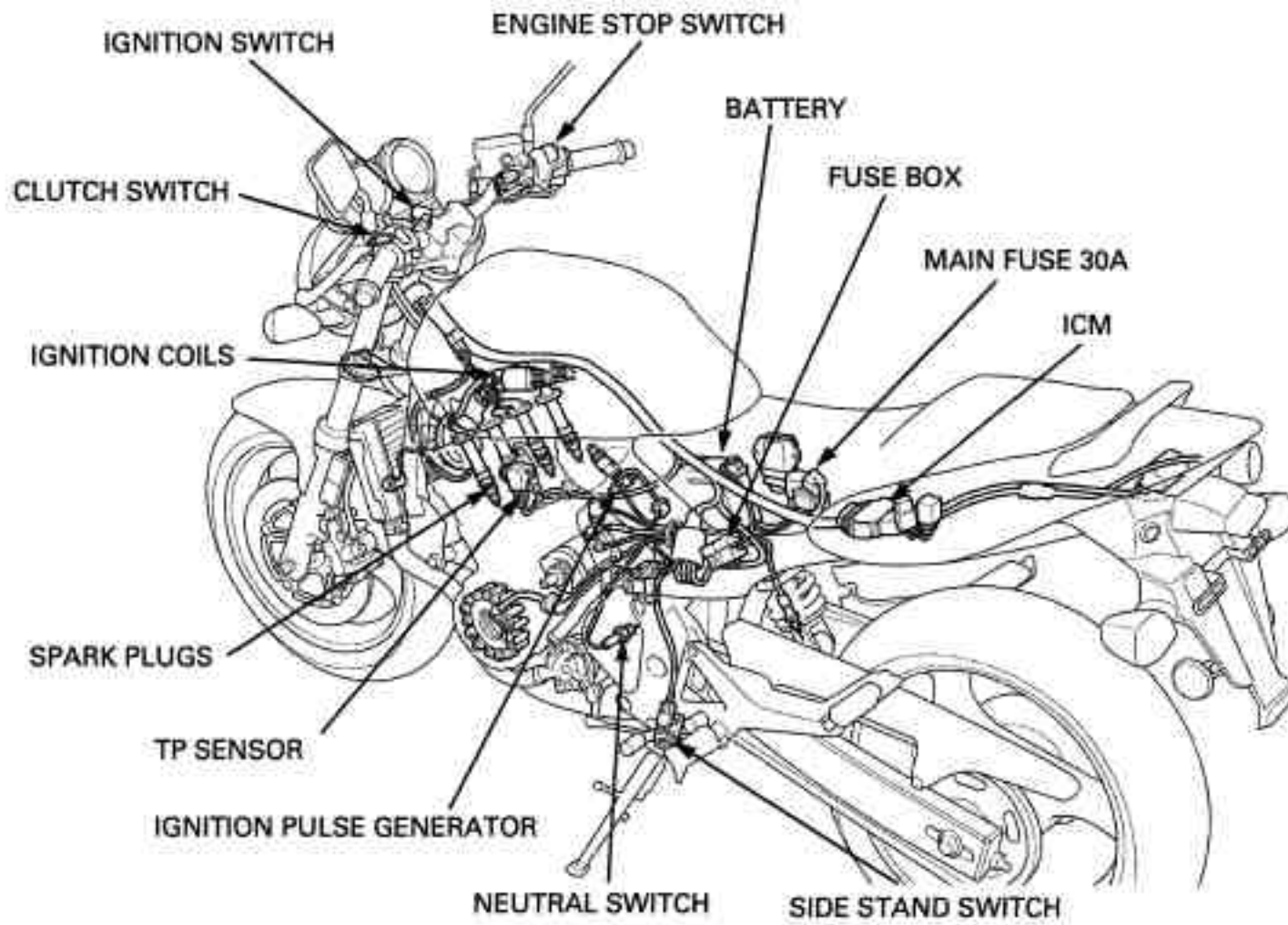

SERVICE INFORMATION

GENERAL

- Some electrical components may be damaged if terminals or connectors are connected or disconnected while the ignition switch is ON and current is present.
- When servicing the ignition system, always follow the steps in the troubleshooting sequence (page 18-4).
- The ignition timing does not normally need to be adjusted since the Ignition Control Module (ICM) is factory preset.
- The ICM may be damaged if dropped. Also if the connector is disconnected when current is flowing, the excessive voltage may damage the module. Always turn off the ignition switch before servicing.
- A faulty ignition system is often related to poor connections. Check those connections before proceeding. Make sure the battery is adequately charged. Using the starter motor with a weak battery results in a slower engine cranking speed as well as no spark at the spark plug.
- Use spark plug of the correct heat range. Using spark plug with an incorrect heat range can damage the engine.
- Refer to the Throttle Position (TP) sensor inspection and ICM inspection (page 18-10).



SPECIFICATIONS

ITEM		SPECIFICATIONS
Spark plug (Iridium)	NGK	CR9EH-9
	DENSO	W27FER9
Spark plug gap		0.80 – 0.90 mm (0.031 – 0.035 in)
Ignition coil peak voltage		100 V minimum
Ignition pulse generator peak voltage		0.7 V minimum
Ignition timing ("F" mark)		7° BTDC at idle

TORQUE VALUES

Timing hole cap	18 N·m (1.8 kgf·m, 13 lbf·ft)	Apply grease to the threads
Spark plug	12 N·m (1.2 kgf·m, 9 lbf·ft)	'04 model
Spark plug	18 N·m (1.8 kgf·m, 13 lbf·ft)	After '04 model
Ignition pulse generator rotor special bolt	59 N·m (6.0 kgf·m, 43 lbf·ft)	

TOOLS

<p>Peak voltage adaptor 07HGJ-0020100 (not available in U.S.A.)</p>  <p>with commercially available digital multimeter (impedance 10 MΩ/DCV minimum)</p>	<p>Ignition Mate peak voltage tester MTP07-0286 (U.S.A. only)</p> 
---	--

TROUBLESHOOTING

- Inspect the following before diagnosing the system.
 - Faulty spark plug
 - Loose spark plug cap or spark plug wire connection
 - Water got into the direct ignition coil (leaking the ignition coil secondary voltage)
- If there is no spark at any cylinder, temporarily exchange the direct ignition coil with another good one and perform the spark test. If there is spark, the exchanged direct ignition coil is faulty.
- "Initial voltage" of the ignition primary coil is the battery voltage with the ignition switch ON and engine stop switch at RUN (The engine is not cranked by the starter motor).

No spark at all plugs

	Unusual condition	Probable cause (Check in numerical order)
Ignition coil primary voltage	No initial voltage with ignition and engine stop switches ON. (Other electrical components are normal)	<ol style="list-style-type: none"> 1. Faulty engine stop switch. 2. An open circuit in Black/white wire between the ignition coil and engine stop switch. 3. Loose or poor connect of the direct ignition coil primary wire terminal, or an open circuit in primary coil (Check at the ICM connector). 4. Faulty ICM (in case when the initial voltage is normal while disconnecting ICM connector)
	Initial voltage is normal, but it drops down to 2 – 4 V while cranking the engine.	<ol style="list-style-type: none"> 1. Incorrect peak voltage adaptor connections. 2. Undercharged battery. 3. No voltage between the Black/white (+) and Body ground (-) at the ICM multi-connector or loosen ICM connection. 4. An open circuit or loose connection in Green wire. 5. An open circuit or loose connection in Yellow/blue, Blue/yellow wires between the ignition coils and ICM. 6. Short circuit in ignition primary coil. 7. Faulty side stand switch or neutral switch. 8. An open circuit or loose connection in No.7 related circuit wires. <ul style="list-style-type: none"> – Side stand switch line: Green/white wire – Neutral switch line: Green/red wire 9. Faulty ignition pulse generator (measure the peak voltage). 10. Faulty ICM (when No. 1 through 9 are normal).
	Initial voltage is normal, but no peak voltage while cranking the engine.	<ol style="list-style-type: none"> 1. Faulty peak voltage adaptor connections. 2. Faulty peak voltage adaptor. 3. Faulty ECM (when No.1, 2 are normal).
	Initial voltage is normal, but peak voltage is lower than standard value.	<ol style="list-style-type: none"> 1. The multimeter impedance is too low; below 10 MΩ/DCV. 2. Cranking speed is too low (battery under charged). 3. The sampling timing of the tester and measured pulse were not synchronized (system is normal if measured voltage is over the standard voltage at least once). 4. Faulty ICM (when No. 1 through 3 are normal).
	Initial and peak voltage are normal, but does not spark.	<ol style="list-style-type: none"> 1. Faulty spark plug or leaking ignition coil secondary current ampere. 2. Faulty ignition coil (s).
Ignition pulse generator	Peak voltage is lower than standard value.	<ol style="list-style-type: none"> 1. The multimeter impedance is too low; below 10 MΩ/DCV. 2. Cranking speed is too low (battery under charged). 3. The sampling timing of the tester and measured pulse were not synchronized (system is normal if measured voltage is over the standard voltage at least once). 4. Faulty ICM (when No. 1 through 3 are normal).
	No peak voltage.	<ol style="list-style-type: none"> 1. Faulty peak voltage adaptor. 2. Faulty ignition pulse generator.

IGNITION SYSTEM INSPECTION

- If there is no spark at any plug, check all connections for loose or poor contact before measuring each peak voltage.
- Use recommended digital multimeter or commercially available digital multimeter with an impedance of 10 M Ω /DCV minimum.
- The display value differs depending upon the internal impedance of the multimeter.

Connect the peak voltage tester or peak voltage adaptor to the digital multimeter.

TOOLS:

Ignition Mate peak voltage tester MTP07-0286 (U.S.A. only) or
Peak voltage adaptor 07HGJ-0020100 (not available in U.S.A.)

with commercially available digital multimeter (impedance 10 M Ω /DCV minimum)

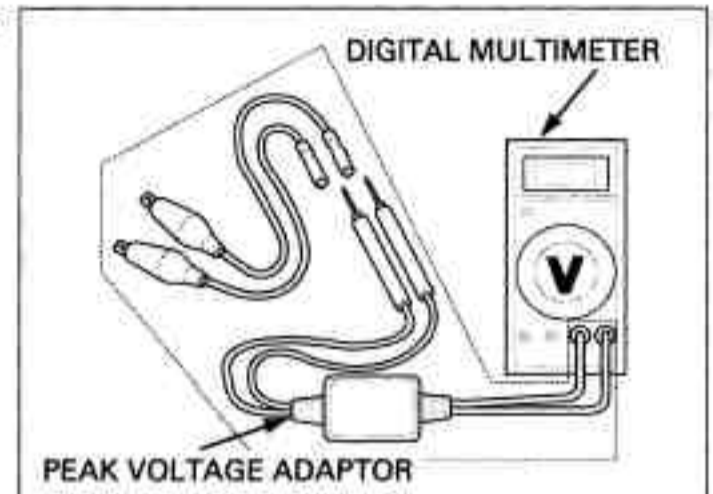

IGNITION COIL PRIMARY PEAK VOLTAGE

- Check all system connections before inspection. If the system is disconnected, incorrect peak voltage might be measured.
- Check cylinder compression and check that the spark plugs are installed correctly.

Disconnect the spark plug caps from the spark plugs (page 4-7).

Shift the transmission into neutral.

Connect a known good spark plugs to the direct ignition coils and ground the spark plugs to the cylinder head as done in a spark test.

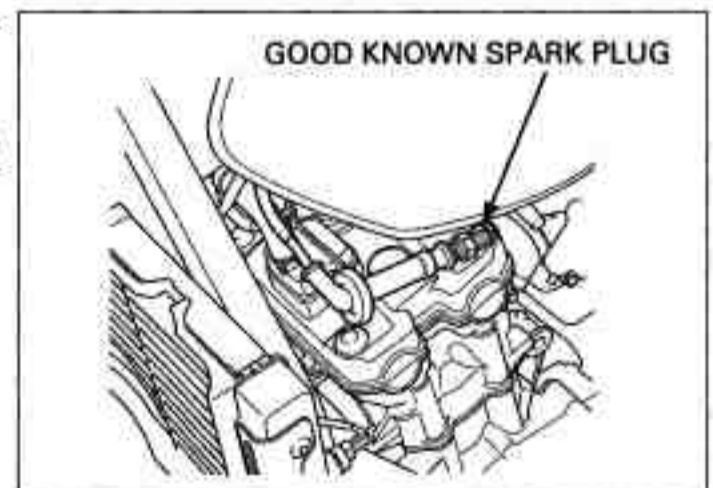

With the ignition coil primary wire connected, connect the peak voltage adaptor or peak voltage tester to the ignition coil primary wire terminals.

CONNECTION:

- No.1/4 coil:**
 Yellow/blue (+) - Ground (-)
- No.2/3 coil:**
 Blue/yellow (+) - Ground (-)

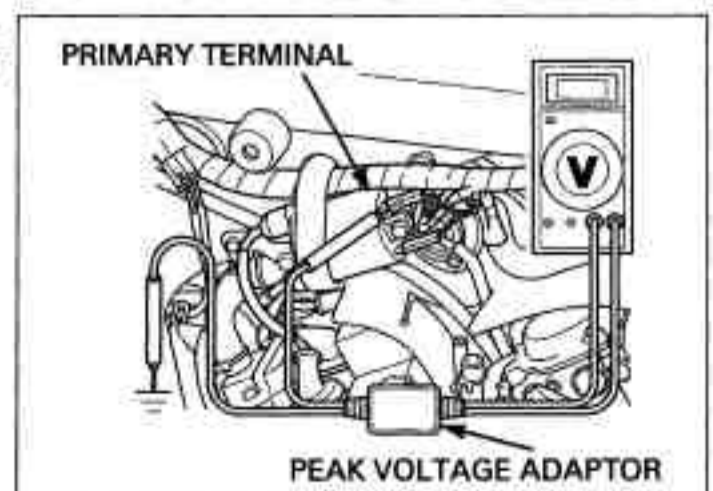

IGNITION SYSTEM

Turn the ignition switch "ON" and engine stop switch to "RUN".

Check for initial voltage at this time.

The battery voltage should be measured.

If the initial voltage cannot be measured, check the power supply circuit (page 18-4).

Avoid touching the spark plugs and tester probes to prevent electric shock.

Crank the engine with the starter motor and read ignition coil primary peak voltage.

PEAK VOLTAGE: 100V minimum

If the peak voltage is abnormal, check for an open circuit or poor connection in Blue/black, Yellow/white, Red/blue and Red/yellow wires.

If not defects are found in the harness, refer to the troubleshooting chart (page 18-4).

IGNITION PULSE GENERATOR PEAK VOLTAGE

- Check all system connection before inspection. If the system is disconnected, incorrect peak voltage might be measured.
- Check cylinder compression and check that the spark plugs are installed correctly.

Remove the seat (page 3-4).

Disconnect the 22P connector from the ICM.

Connect the peak voltage tester or peak voltage adaptor probes to the ICM connector terminals of the wire harness side.

TOOLS:

Ignition Mate peak voltage tester MTP07-0286 (U.S.A. only) or
Peak voltage adaptor 07HGJ-0020100 (not available in U.S.A.)

with commercially available digital multimeter (impedance 10 M Ω /DCV minimum)

CONNECTION:

Yellow (+) - White/yellow (-)

Avoid touching the spark plugs and tester probes to prevent electric shock.

Crank the engine with the starter motor and read the peak voltage.

PEAK VOLTAGE: 0.7 V minimum

If the peak voltage measured at ICM 22P connector is abnormal, measure the peak voltage at the ignition pulse generator connector.

Remove the left side cover (page 3-4).

Disconnect the ignition pulse generator 2P (Blue) connector and connect the tester probes to the terminal (Yellow and White/yellow).

In the same manner as at the ICM connector, measure the peak voltage and compare it to the voltage measured at the ICM connector.

- If the peak voltage measured at the ICM is abnormal and the one measured at the ignition pulse generator is normal, the wire harness has an open circuit or loose connection.
- If both peak voltages measure are abnormal, check each item in the troubleshooting chart. If all items are normal, the ignition pulse generator is faulty. See following steps for ignition pulse generator replacement.

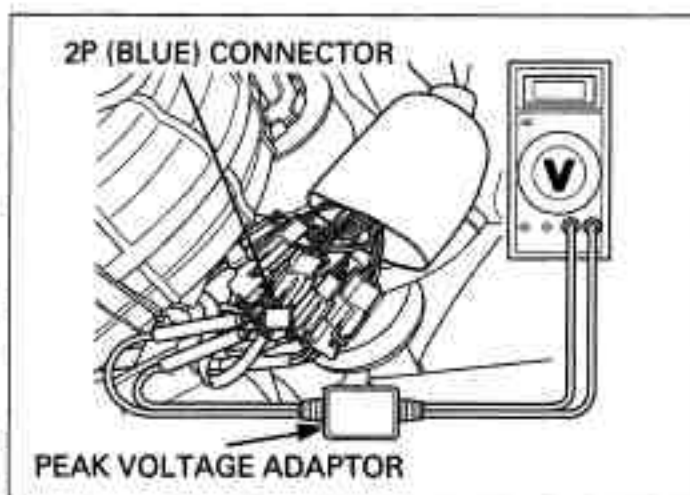
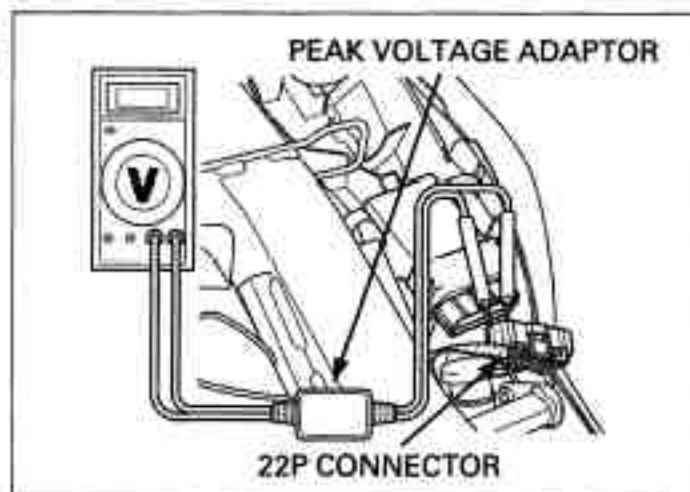

IGNITION PULSE GENERATOR

REMOVAL

Remove the air cleaner housing (page 6-7).

Disconnect the ignition pulse generator 2P (Blue) connector.

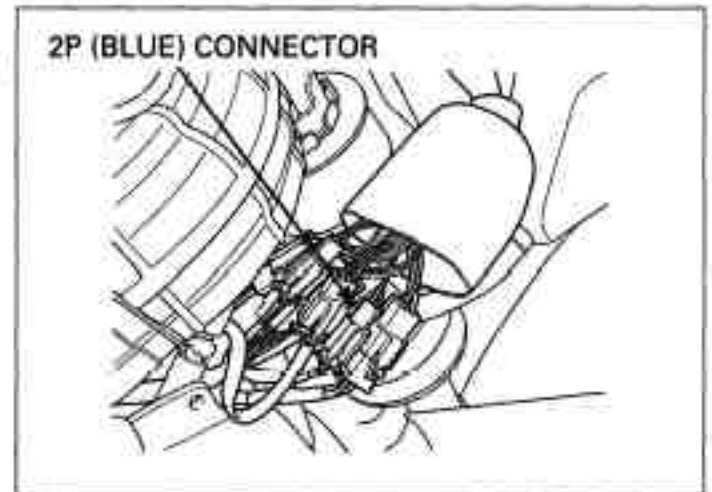

Remove the wire band.

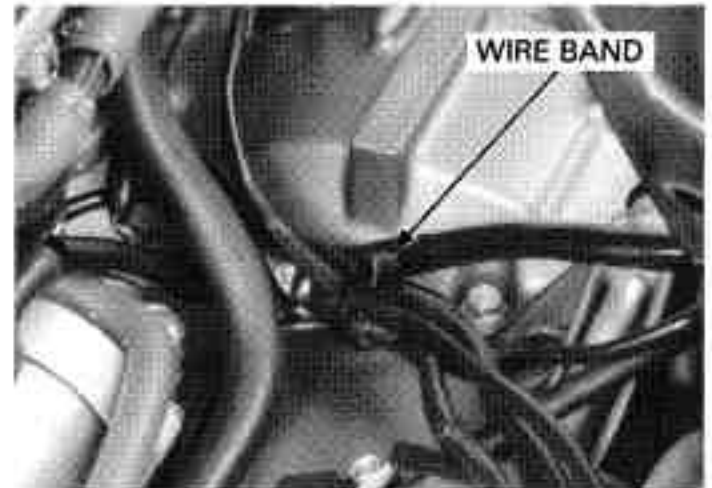

Remove the bolts and ignition pulse generator rotor cover.

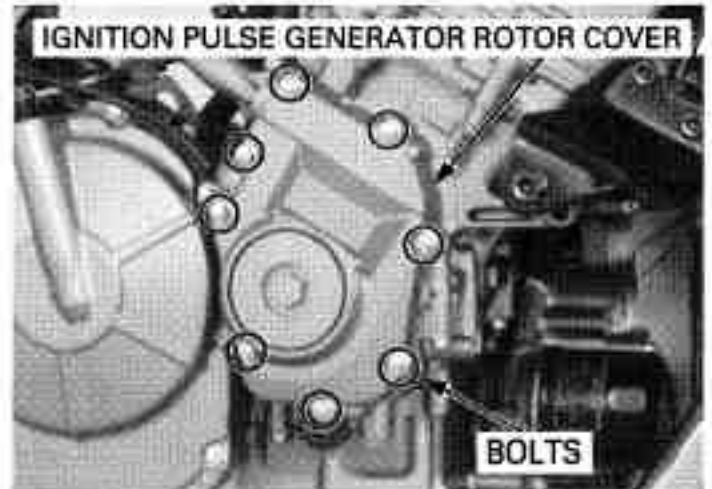

Remove the gasket and dowel pins.

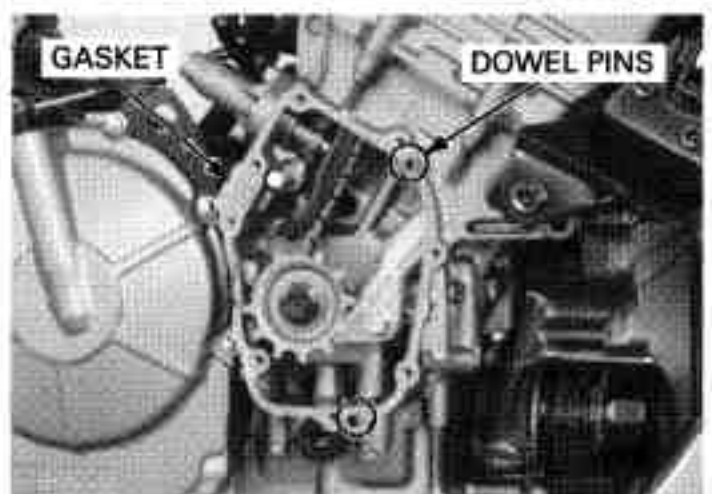

IGNITION SYSTEM

Remove the wire grommet from the cover.
Remove the bolts and ignition pulse generator.

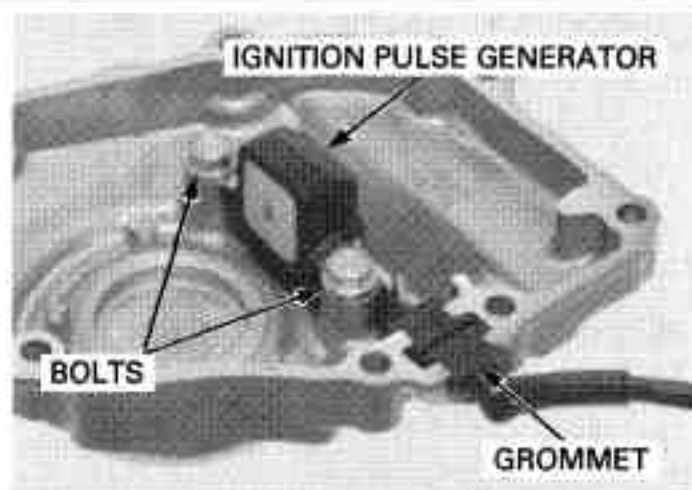

If the engine is out of the frame, remove the alternator cover (page 11-4) and hold the flywheel with the flywheel holder (07725-0040000), then remove the bolt.

Shift the transmission into 6th gear and apply rear brake.
Remove the ignition pulse generator rotor special bolt and washer.

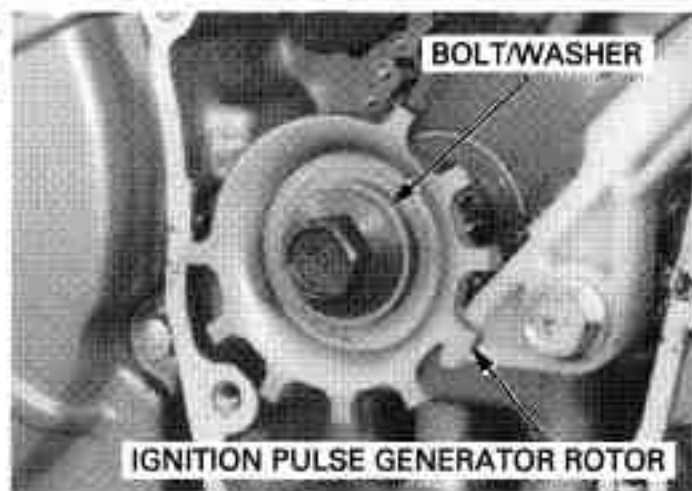

INSTALLATION

Install the ignition pulse generator rotor by aligning the wide groove with the wide teeth of the crankshaft.

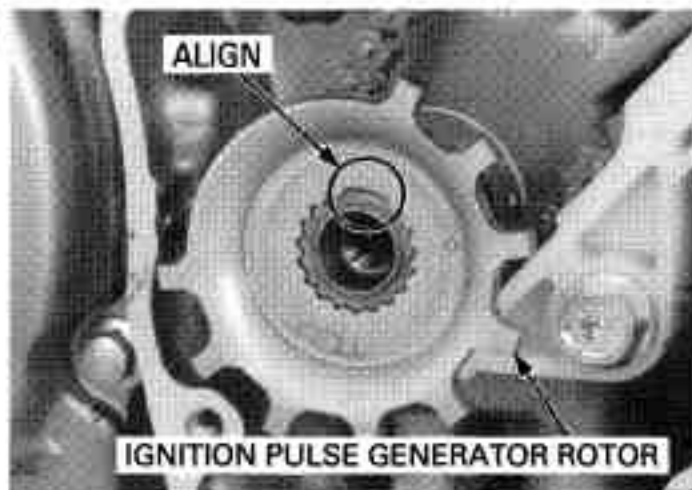

Install the washer and ignition pulse generator rotor special bolt.

If the engine is out of frame, remove the alternator cover (page 11-4) and hold the flywheel with the flywheel holder (07725-0040000), then tighten the bolt.

Shift the transmission into 6th gear and apply rear brake.

Tighten the ignition pulse generator rotor bolt to the specified torque.

TORQUE: 59 N-m (6.0 kgf-m, 43 lbf-ft)

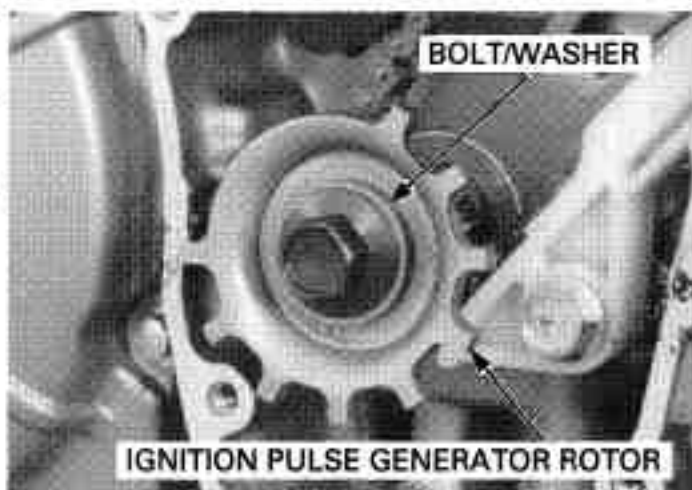

Install the ignition pulse generator into the cover.
 Apply sealant to the wire grommet, then install it into the groove of the cover.
 Install and tighten the ignition pulse generator bolts.

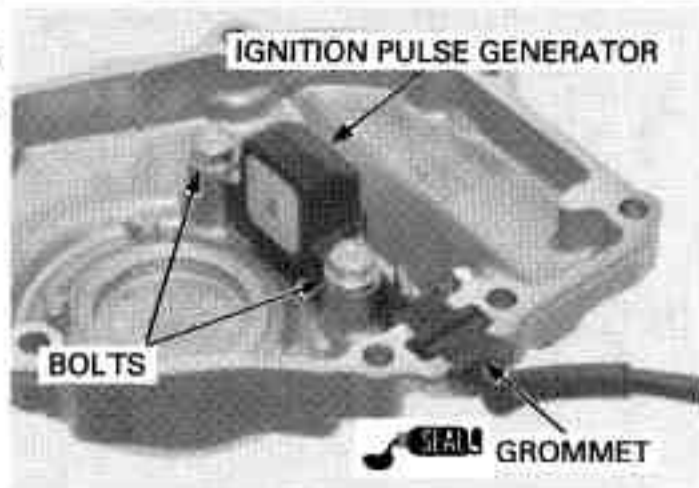

Apply liquid sealant to the mating surface of the crankcase as shown.

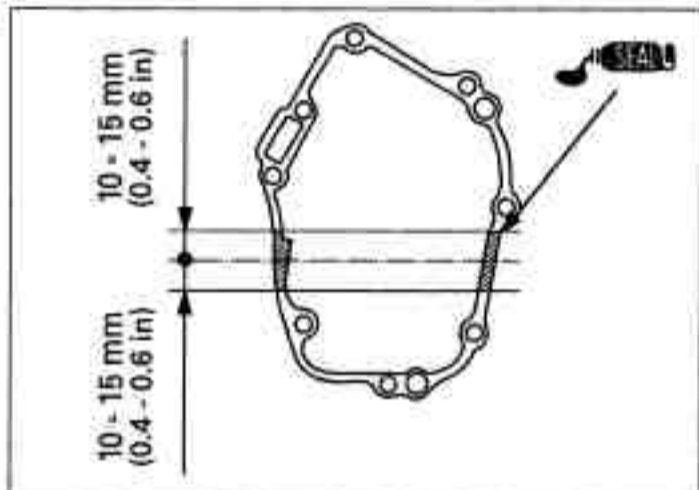

Install the dowel pins and a new gasket.

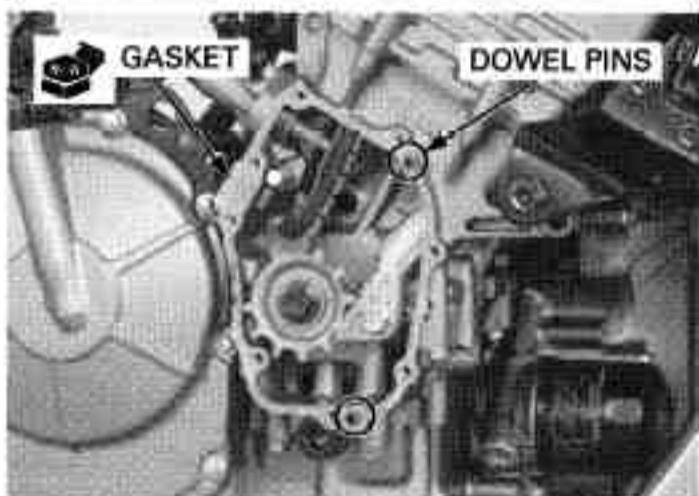

Apply sealant to the threads of the two bolts identification mark on the cover.
 Install the ignition pulse generator rotor cover and tighten the bolts securely.

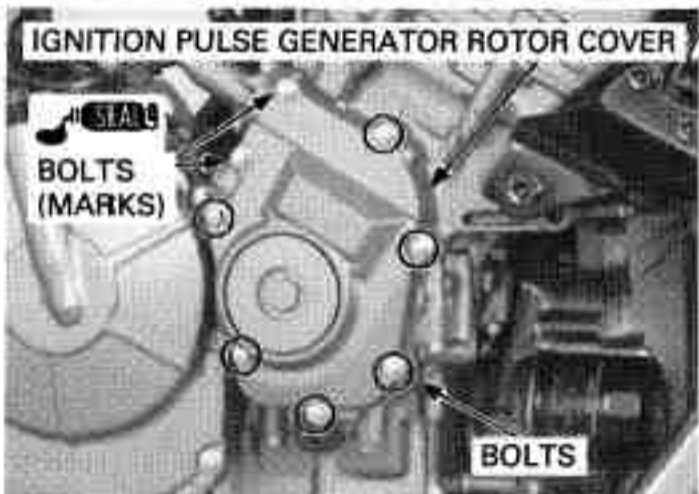

IGNITION SYSTEM

Route the ignition pulse generator wire properly.
Clamp the ignition pulse generator wire with the wire band.

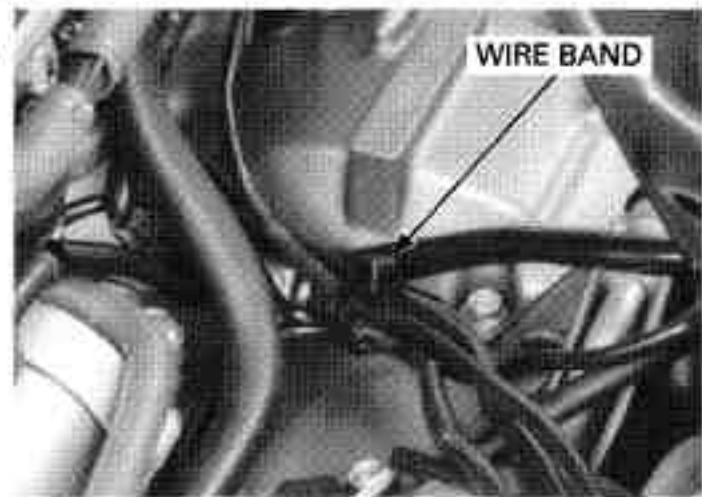

Connect the ignition pulse generator 2P (Blue) connector.

Install the air cleaner housing (page 6-8).

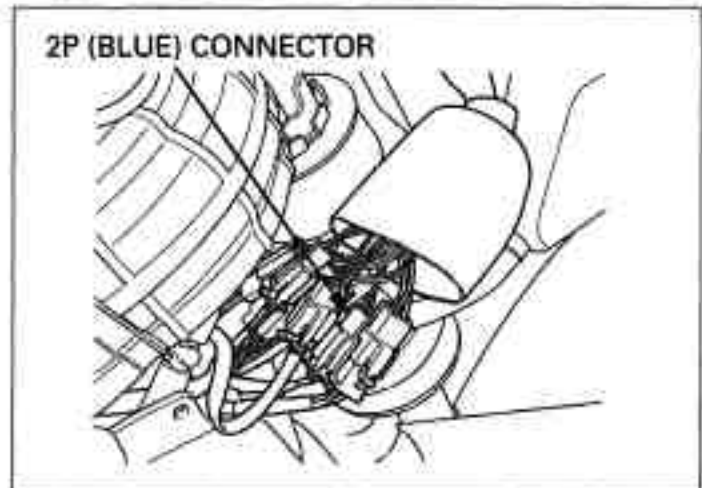

IGNITION COIL

REMOVAL/INSTALLATION

Remove the fuel tank (page 3-6).
Disconnect the spark plug caps from the spark plugs (page 4-7).

Remove the hook of the heat rubber from the hole on the heat rubber.

Disconnect the ignition coil primary wires from the ignition coil.

Remove the bolts and ignition coil.

Installation is in the reverse order of removal.

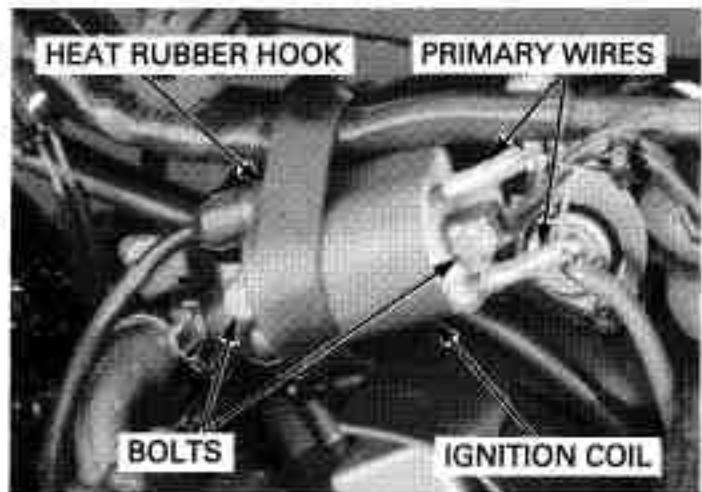

TP SENSOR

INSPECTION

Remove the seat (page 3-4).

Disconnect the ICM 22P connector.
Check the connector for loose or corroded terminals.

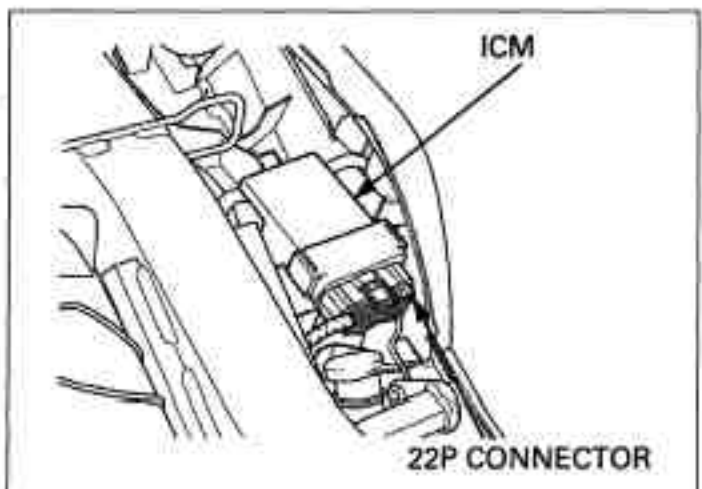

INPUT VOLTAGE INSPECTION

Turn the ignition switch ON and engine stop switch "RUN".

Disconnect the TP sensor 3P connector.

Measure and record the input voltage at the TP sensor 3P connector wire harness side terminals using a digital multimeter.

Connection: Yellow/black (+) – Blue/green (-)
Standard: 4.75 – 5.25 V

If the measurement is out of specification, check the following:

- Loose connection of the ICM 22P connector
- Open circuit in wire harness.

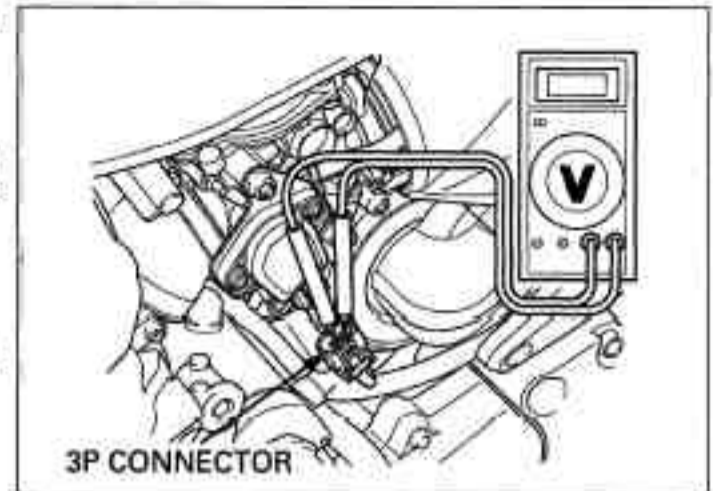

OPERATION INSPECTION

Connect the TP sensor 3P connector.

Disconnect the ICM 22P connector.

Check that the resistance at the 22P connector terminals while operating the throttle grip.

Connection:

Red/yellow – Blue/green
Fully close – Fully open position:
Resistance increases
Fully open – Fully close position:
Resistance decreases

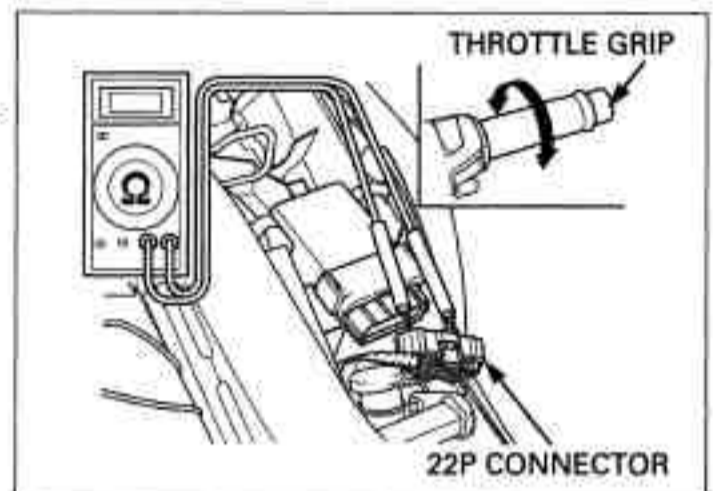

If the resistance at ICM 22P connector is abnormal, measure the resistance at the TP sensor 3P connector.

Disconnect the TP sensor 3P connector and connect the tester to the terminal (Red/yellow and Blue/green).

In the same manner as at the ICM connector, measure the resistance and compare it to the resistance measured at the ICM connector.

- If the measurement at the ICM is abnormal and the one measured at the TP sensor is normal, the wire harness has an open circuit or loose connection.
- If both resistance measure are abnormal, replace the TP sensor (page 6-15).

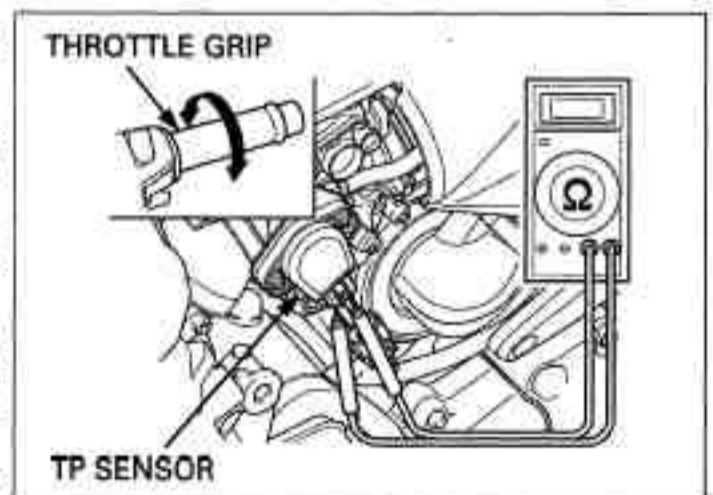

CONTINUITY INSPECTION

Remove the seat (page 3-4).

Disconnect the ICM 22P connector and the TP sensor 3P connector.

Check for continuity between the ICM and TP sensor.

If there is no continuity, check the open or short circuit in wire harness.

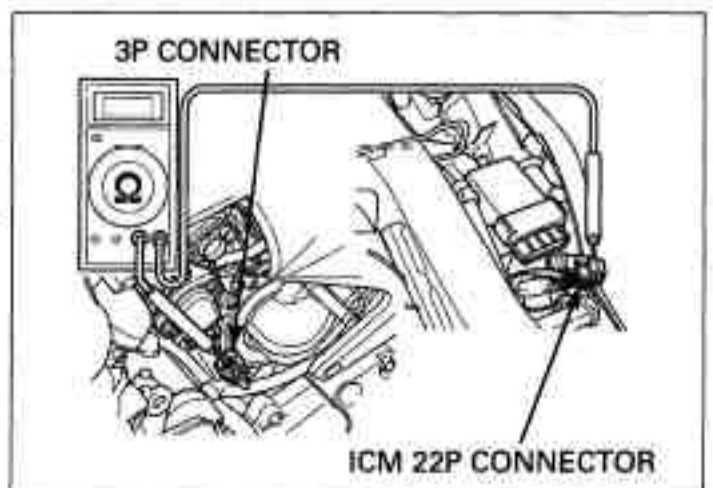

IGNITION SYSTEM

IGNITION CONTROL MODULE (ICM)

REMOVAL/INSTALLATION

Remove the seat (page 3-4).

Disconnect the ICM 22P connector.
Remove the ICM from the rear fender.

Installation is in the reverse order of removal.

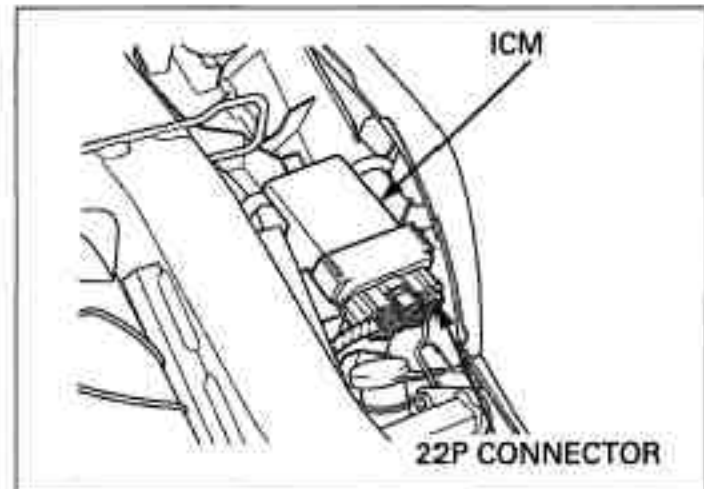

IGNITION TIMING

Warm up the engine.

Stop the engine and remove the timing hole cap.

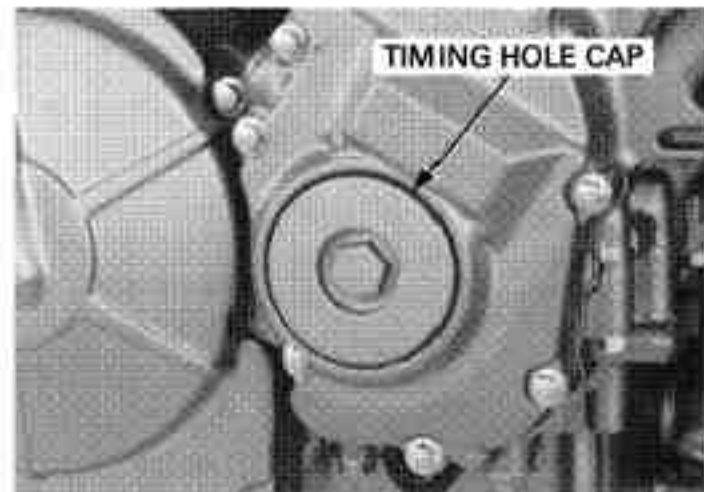

Read the instructions for timing light operation.

Connect the timing light to the No.1 spark plug wire.

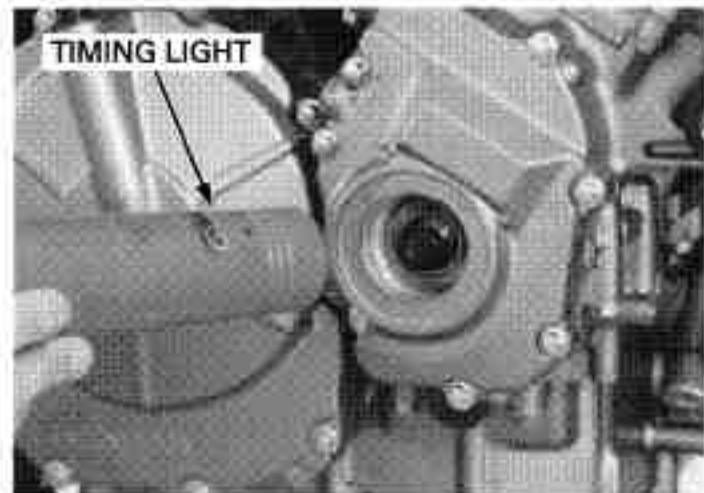

Start the engine and let it idle.

IDLE SPEED: 1,400 ± 100 rpm

The ignition timing is correct if the index mark on the right crankcase cover aligns between the two punch marks and three punch marks on the ignition pulse generator rotor as shown.

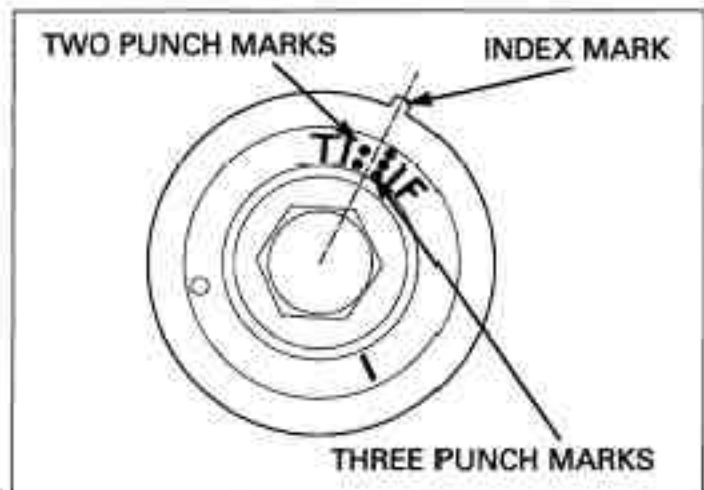

Check the O-ring is in good condition, replace if necessary.

Apply grease to the timing hole cap threads and install the O-ring and timing hole cap.

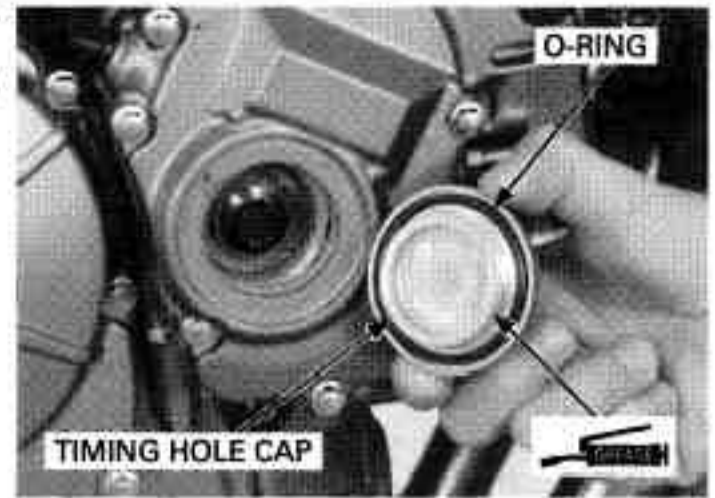

Tighten the timing hole cap to the specified torque.

TORQUE: 18 N·m (1.8 kgf·m, 13 lbf·ft)

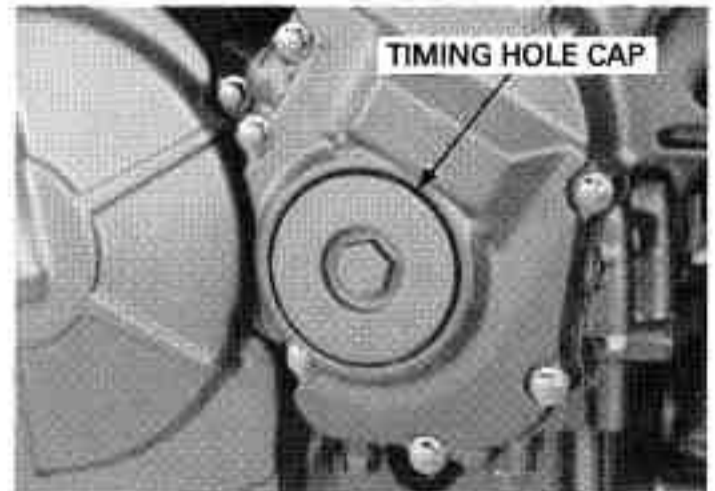

19. ELECTRIC STARTER

SYSTEM DIAGRAM.....	19-2	STARTER MOTOR.....	19-6
SERVICE INFORMATION	19-3	STARTER RELAY SWITCH.....	19-14
TROUBLESHOOTING	19-4	DIODE.....	19-15

ELECTRIC STARTER SYSTEM DIAGRAM

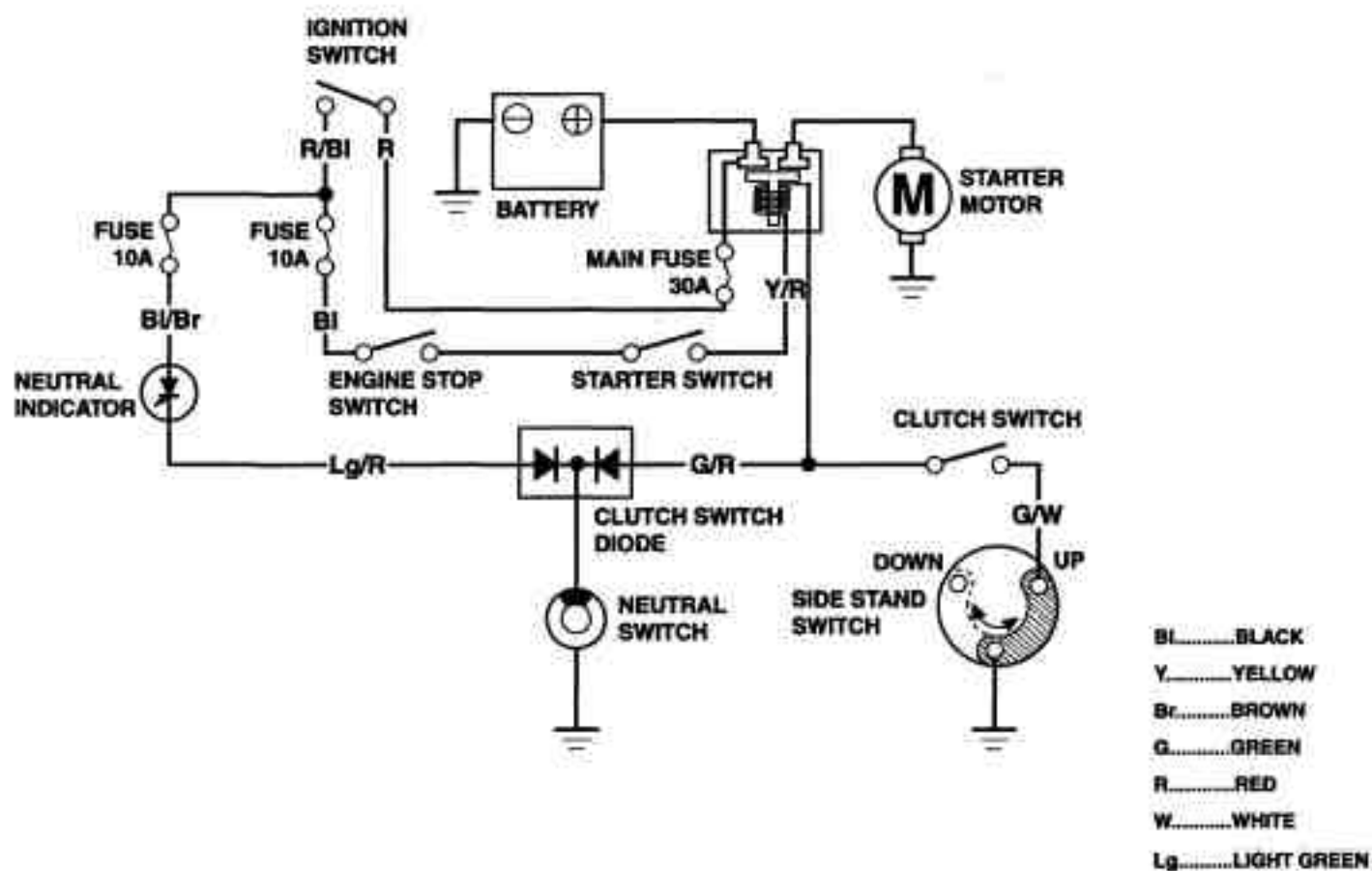
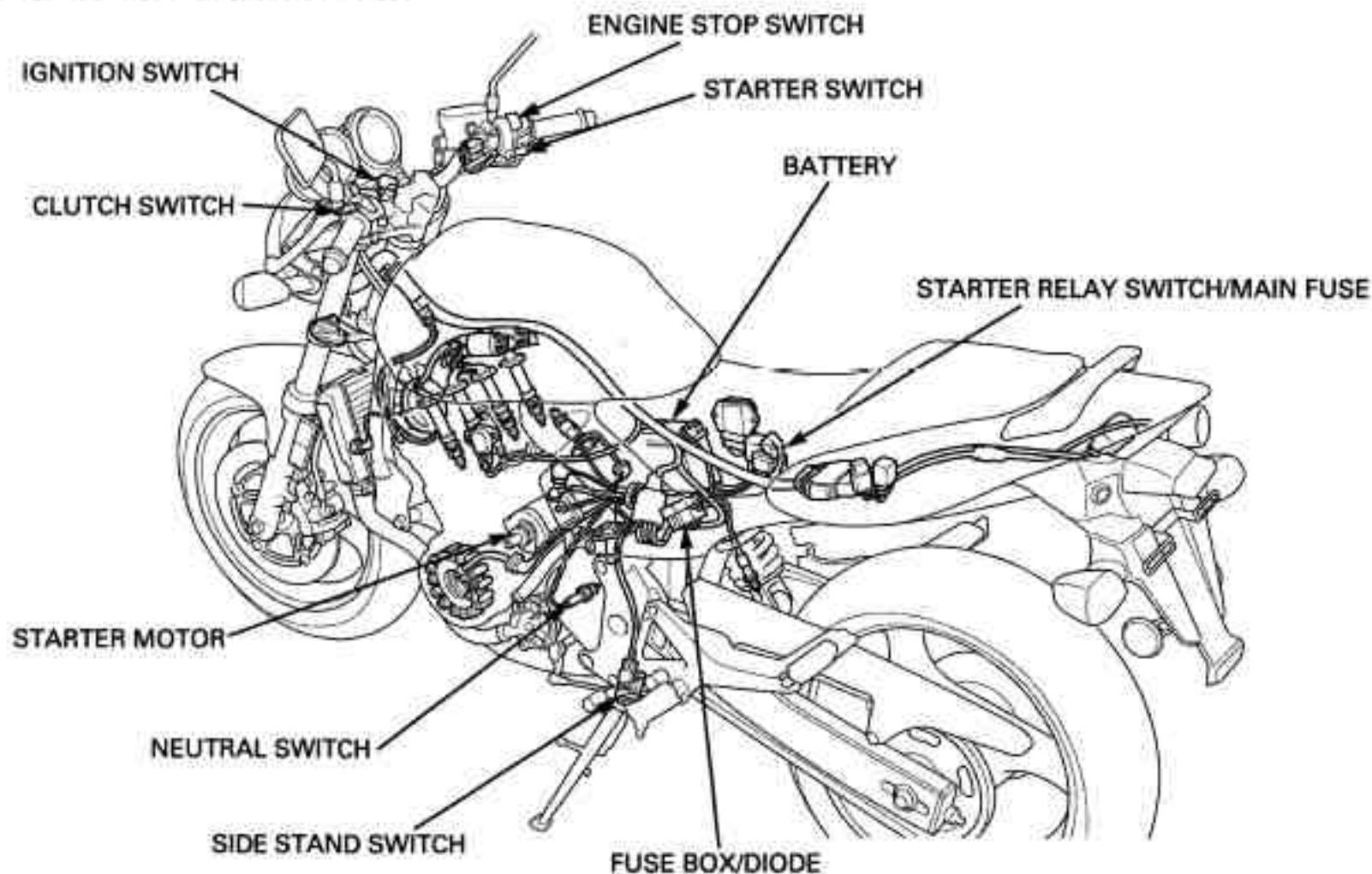

SERVICE INFORMATION

GENERAL

- Always turn the ignition switch OFF before servicing the starter motor. The motor could suddenly start, causing serious injury.
- When checking the starter system, always follow the steps in the troubleshooting flow chart (page 19-4).
- A weak battery may be unable to turn the starter motor quickly enough, or supply adequate ignition current.
- If the current is kept flowing through the starter motor to turn it while the engine is not cranking over, the starter motor may be damaged.
- Refer to the starter clutch servicing (page 11-7).
- Refer to the following components informations.
 - Ignition switch (page 20-26)
 - Engine stop switch (page 20-27)
 - Starter switch (page 20-27)
 - Neutral switch (page 20-29)
 - Side stand switch (page 20-29)
 - Clutch switch (page 20-28)

SPECIFICATIONS

Unit: mm (in)

ITEM	STANDARD	SERVICE LIMIT
Starter motor brush length	12.0 – 13.0 (0.47 – 0.51)	4.5 (0.18)

TORQUE VALUE

Starter motor terminal nut 10 N·m (1.0 kgf·m, 7 lbf·ft)

TROUBLESHOOTING

Starter motor does not turn

1. Fuse Inspection

Check for blown main fuse or sub fuse.

Did the fuse blow?

YES – Replace the fuse

NO – GO TO STEP 2.

2. Battery Inspection

Make sure the battery is fully charged and in good condition.

Is the battery in good condition?

YES – Replace the fuse

NO – GO TO STEP 3.

3. Starter Relay switch operation

Check the starter relay switch operation.

You should hear the relay "CLICK" when the starter switch button is depressed.

Did the starter relay "CLICK"?

YES – GO TO STEP 4.

NO – GO TO STEP 5.

4. Starter Motor Inspection

Apply battery voltage to the starter motor directly and check the operation.

Did the starter motor turn?

YES –

- Poorly connected starter motor cable
- Faulty starter relay switch (page 19-14)

NO – Faulty starter motor (page 19-6)

5. Relay Coil Ground Wire Lines Inspection

Disconnect the starter relay switch connector, and check the relay coil ground wire lines as below for continuity:

1. Green/red terminal-clutch switch diode – neutral switch line (with the transmission in neutral and clutch lever released).
2. Green/red terminal/clutch switch – side stand switch line (in any gear except neutral, and with the clutch lever pulled in and the side stand up).

Apply battery voltage to the starter motor directly and check the operation.

Are there continuity?

NO –

- Faulty neutral switch (page 20-29)
- Faulty neutral diode (page 19-15)
- Faulty clutch switch (page 20-28)
- Faulty side stand switch (page 20-29)
- Loose or poor contact connector
- Open circuit in wire harness

YES – GO TO STEP 6.

6. Starter Relay Voltage Inspection

Connect the starter relay switch connector.

With the ignition switch ON and the starter switch pushed, measure the starter relay voltage at the starter switch connector (between Yellow/red (+) and ground (-)).

Apply battery voltage to the starter motor directly and check the operation.

Is there battery voltage?

NO –

- Faulty ignition switch (page 20-26)
- Faulty starter switch (page 19-14)
- Blown out main or sub-fuse
- Faulty clutch (page 20-28)/side stand diode (page 19-15)
- Loose or poor contact connector
- Open circuit in wire harness

YES – GO TO STEP 7.

7. Starter Relay Switch Operation

Check the starter relay switch operation.

Is there battery voltage?

NO – Faulty starter relay switch (page 19-14)

YES – Loose or poor contact starter relay switch connector

The starter motor turns when the transmission is in neutral, but does not turn with the transmission in any position except neutral, with the side stand up and the clutch lever pulled in.

1. Clutch Switch Inspection

Check the clutch switch operation.

Is the clutch switch operation normal?

NO – Faulty clutch switch (page 19-14)

YES – GO TO STEP 2.

2. Clutch Switch Inspection

Check the side stand switch operation.

Is the side stand switch operation normal?

NO – Faulty side stand switch (page 20-29)

YES –

- Open circuit in wire harness
- Loose or poor contact connector

Starter motor turns engine slowly

- Low battery voltage
- Poorly connected battery terminal cable
- Poorly connected starter motor cable
- Faulty starter motor
- Poor connected battery ground cable

Starter motor turns, but engine does not turn

- Starter motor is running backwards
 - Case assembled improperly
 - Terminals connected improperly
- Faulty starter clutch
- Damaged or faulty starter drive gear

Starter relay switch "Clicks", but engine does not turn over

- Crankshaft does not turn due to engine problems

ELECTRIC STARTER

STARTER MOTOR

REMOVAL

Remove the air cleaner housing (page 6-7).
Remove the EVAP canister purge valve (California type).

With the ignition switch OFF, remove the negative cable at the battery before servicing the starter motor.

Remove the rubber cap.

Remove the nut and the starter motor cable from the starter motor.

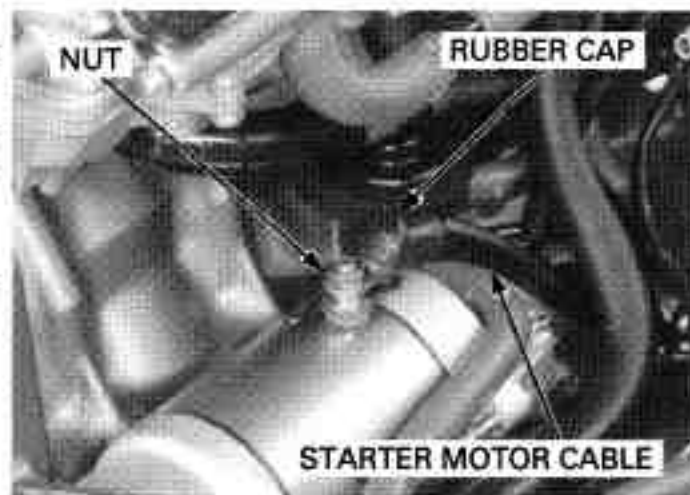

Remove the starter motor mounting bolts and ground cable.

Remove the EVAP canister purge valve stay (California type).

Pull the starter motor out of the crankcase.

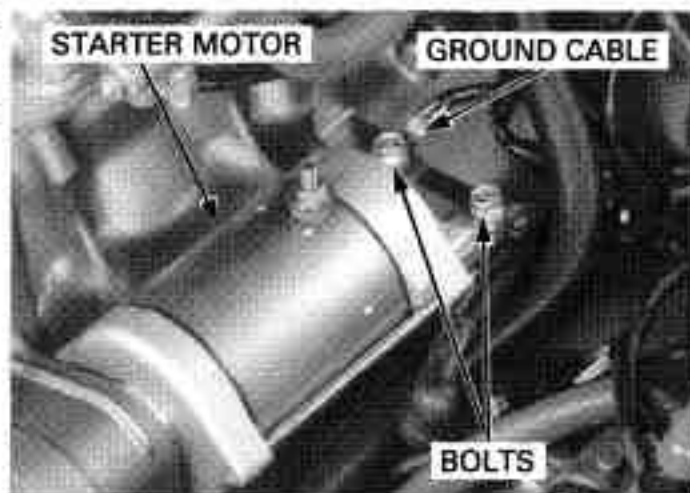

Remove the O-ring.



DISASSEMBLY

Remove the starter motor case bolts.



Record the location
and number of
shims.

Remove the following:

- Front cover
- Seal ring
- Lock washer
- Insulated washer
- Shim (s)

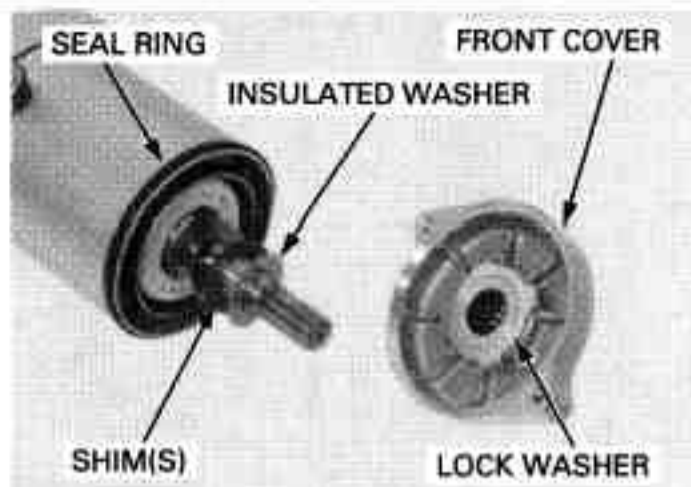

Remove the following:

- Rear cover assembly
- Seal ring
- Shims

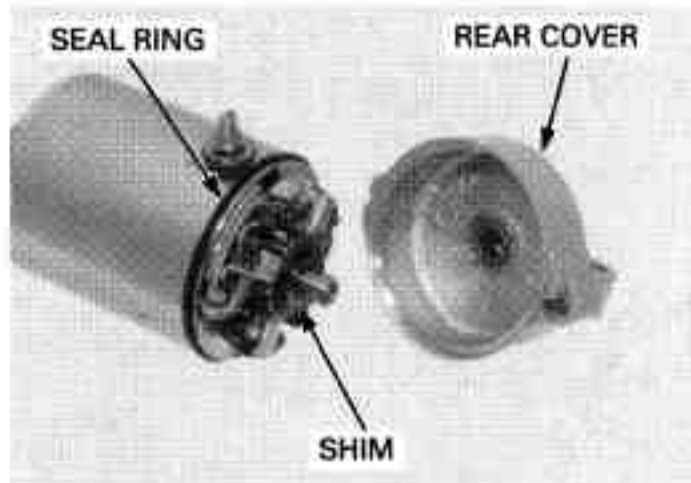

Remove the armature from the starter motor case.

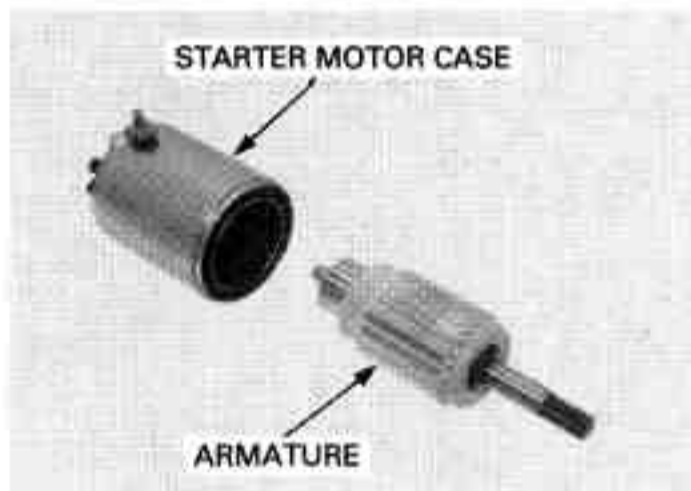

INSPECTION

Check the bushing in the rear cover for wear or damage.

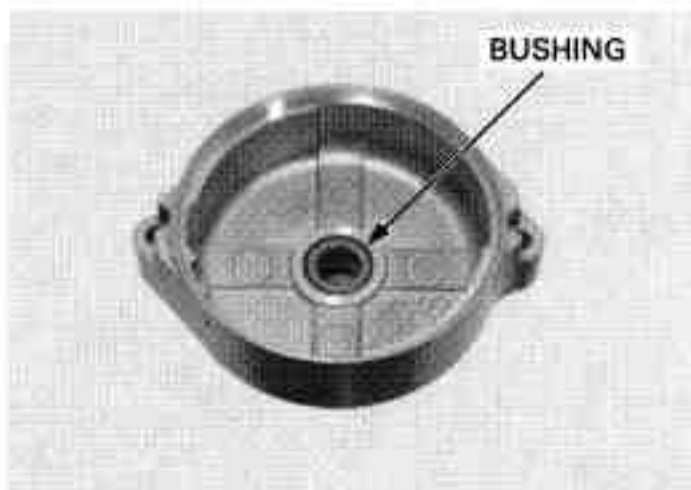

ELECTRIC STARTER

Check the oil seal and needle bearing in the front cover for deterioration, wear or damage.

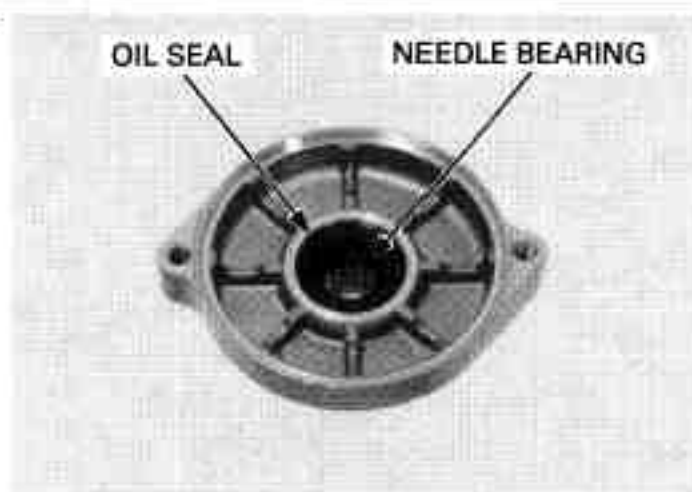

Do not use emery or sand paper on the commutator.

Check the commutator bars of the armature for discoloration.

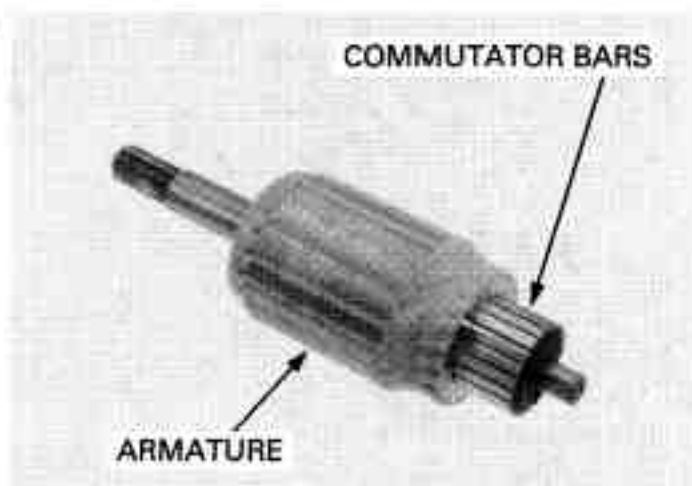

Check for continuity between pairs of commutator bars. There should be continuity.



Check for continuity between each commutator bar and the armature shaft. There should be no continuity.



Check for continuity between the insulated brush and cable terminal (the indigo colored wire or the insulated brush holder).
There should be continuity.

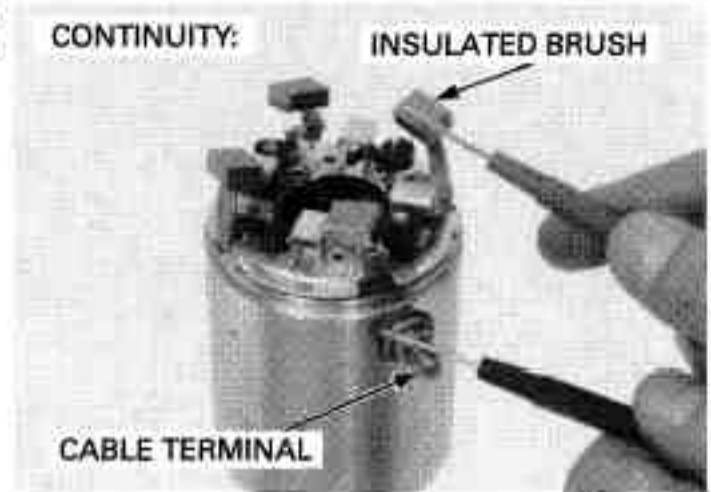

Check for continuity between the insulated brush and the motor case.
There should be no continuity.



Check for continuity between the (+) and (-) terminals of the brush holder.
There should be no continuity.

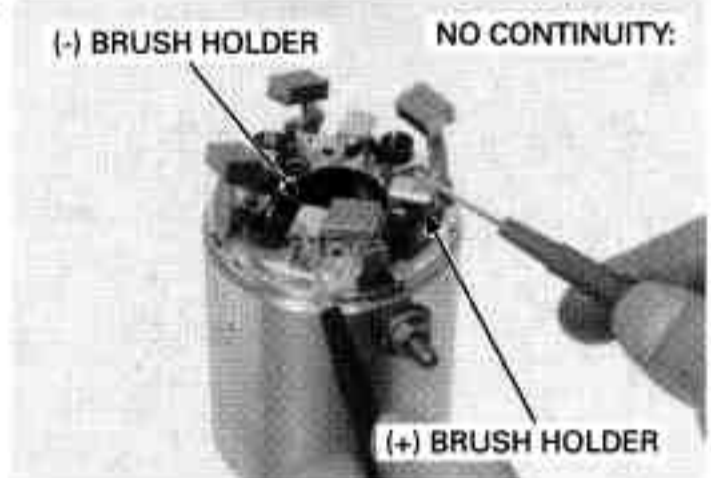

Remove the following:

- Nut
- Washer
- Insulators
- O-ring

Remove the brush holder assembly from the starter motor case.

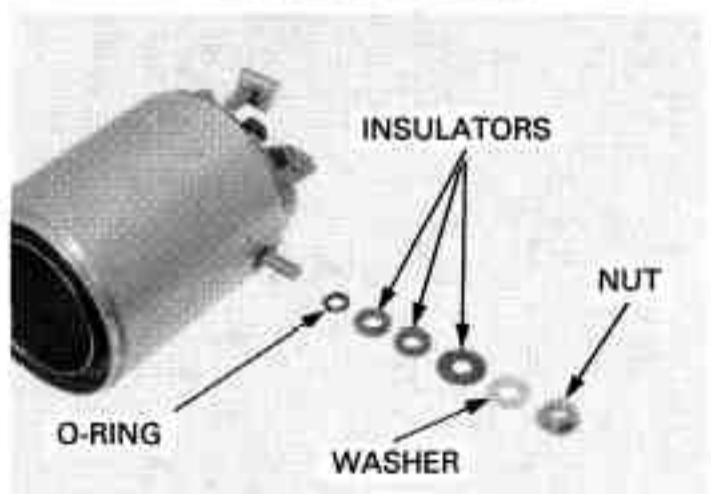

ELECTRIC STARTER

Remove the brush, terminal and set collar from the brush holder.

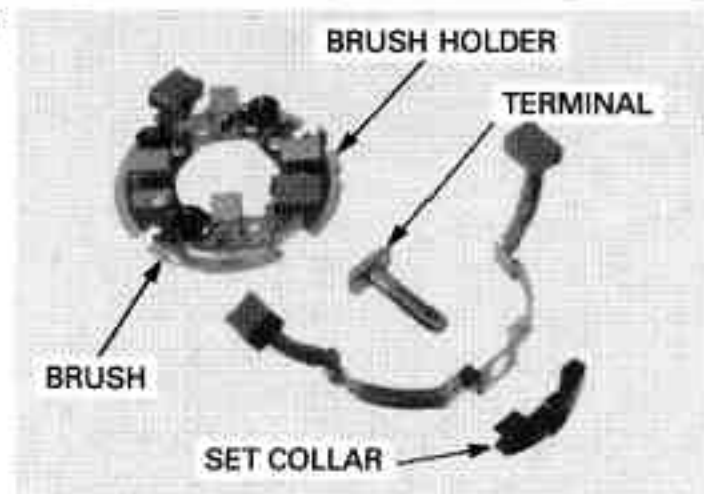

Inspect the brushes for damage and measure the brush length.

SERVICE LIMIT: 4.5 mm (0.18 in)

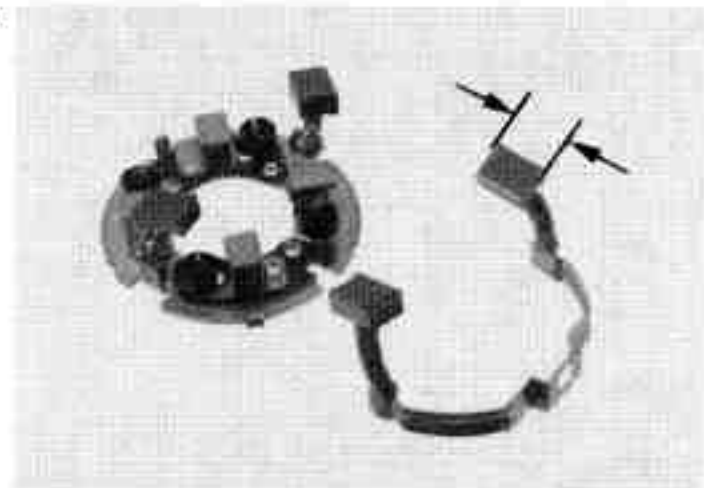

ASSEMBLY

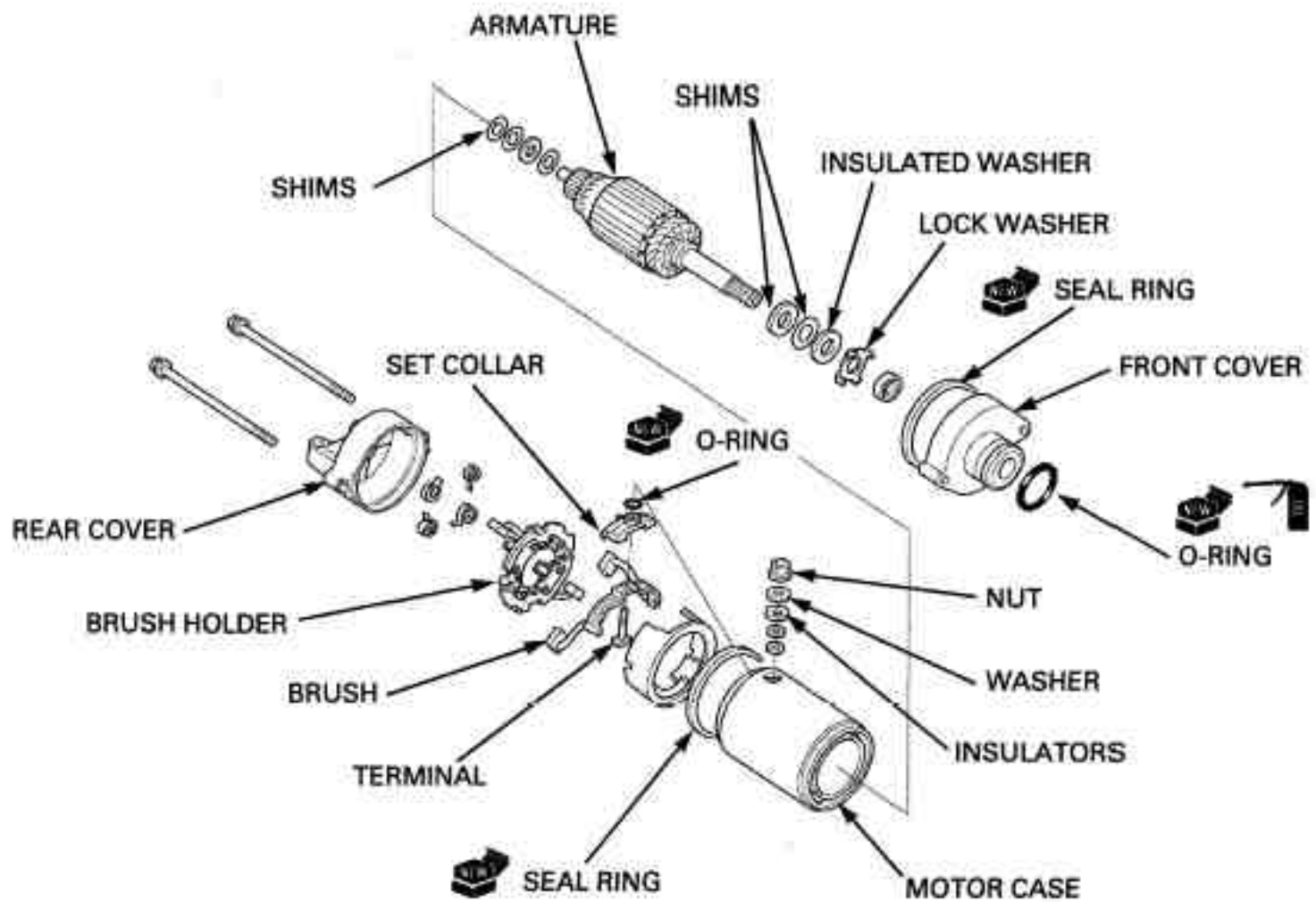

Install the terminal, brushes and set collar into the brush holder.

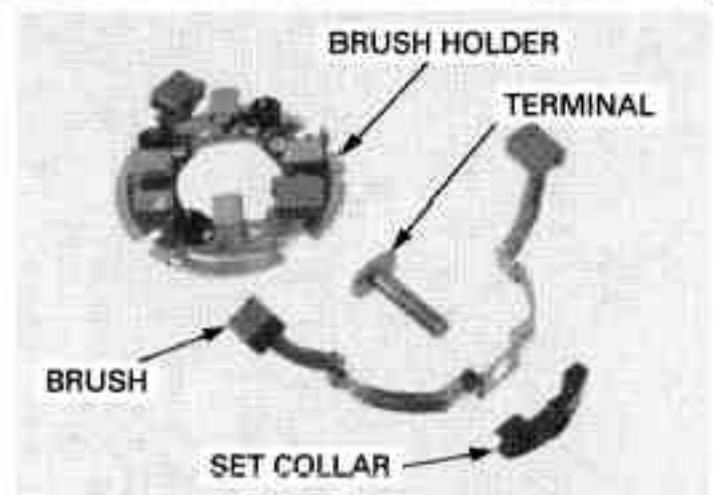

Install the brush holder assembly into the motor case, aligning the terminal with the hole of the motor case.

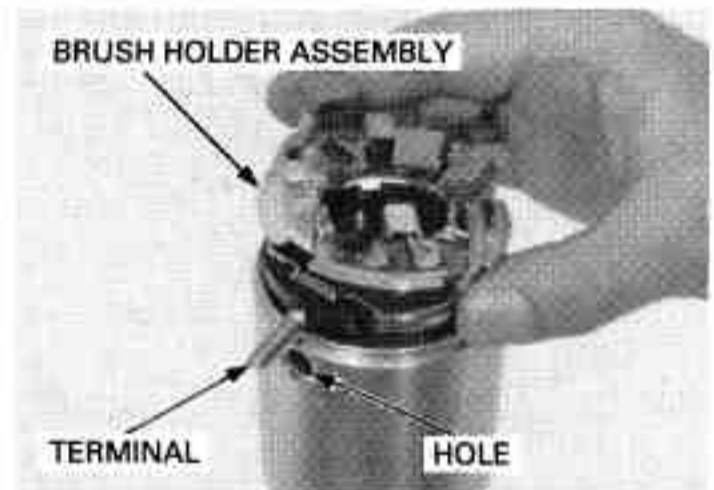

Align the holder tab with the motor case groove.

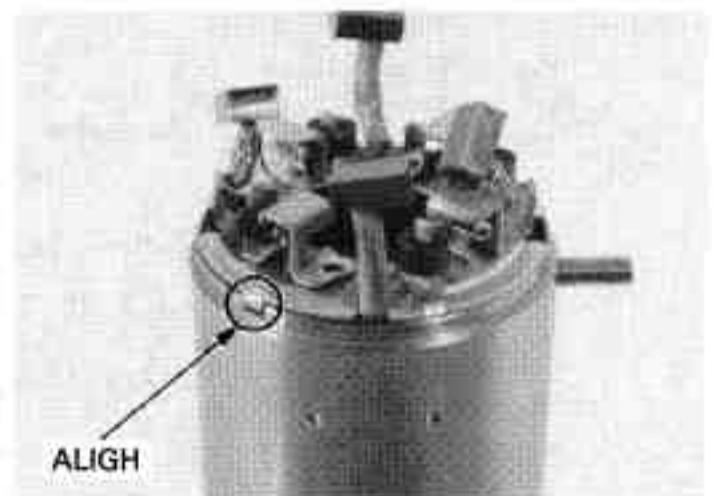

Install the following:

- New O-ring
- Insulators
- Washer
- Nut

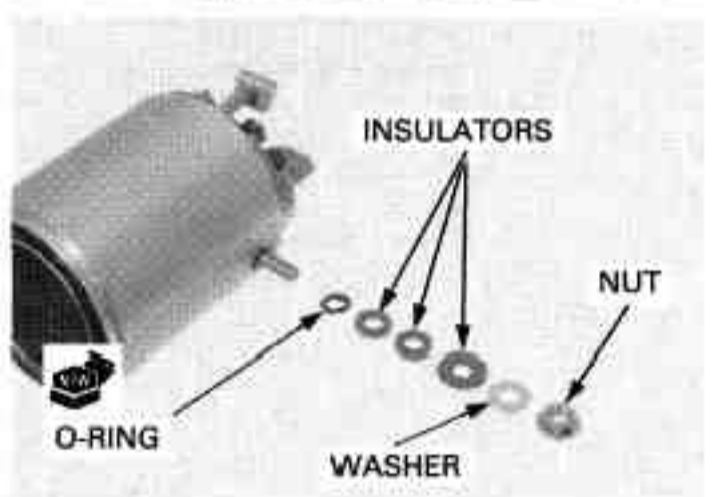

ELECTRIC STARTER

Install the armature in the motor case.
When installing the armature into the motor case, hold the armature tightly to keep the magnet of the case from pulling the armature against it.

NOTICE

The coil may be damaged if the magnet pulls the armature against the case.

Set the brush springs.

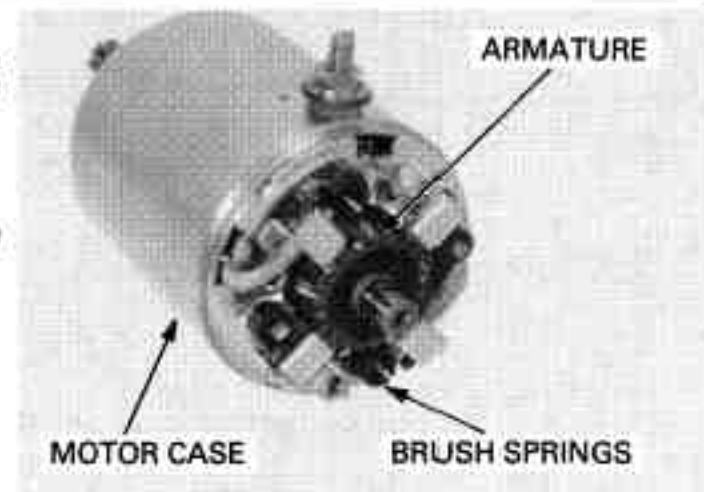

Install the shims properly as noted during removal.

Install the shims onto the armature shaft.
Install a new seal ring onto the motor case.
Apply thin coat of grease to the armature shaft end.
Install the rear cover.

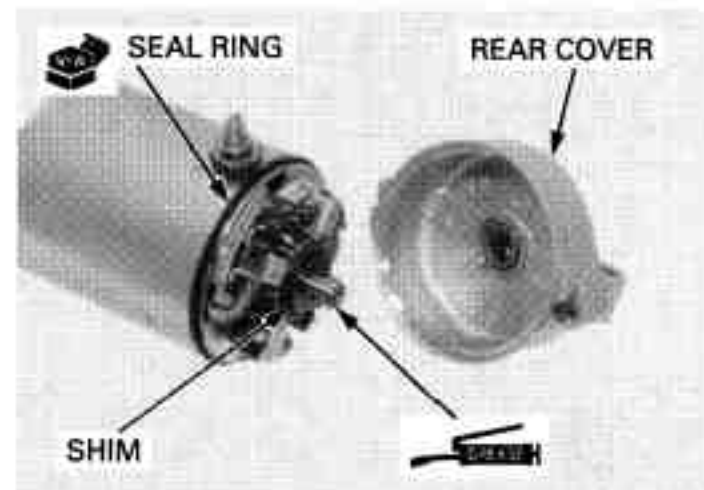

Install the shims properly as noted during removal.

Install the shims and insulated washer onto the armature shaft.
Install a new seal ring onto the motor case.
Apply grease to the oil seal lip and needle bearing in the front cover.
Install the lock washer onto the front cover.
Install the front cover.

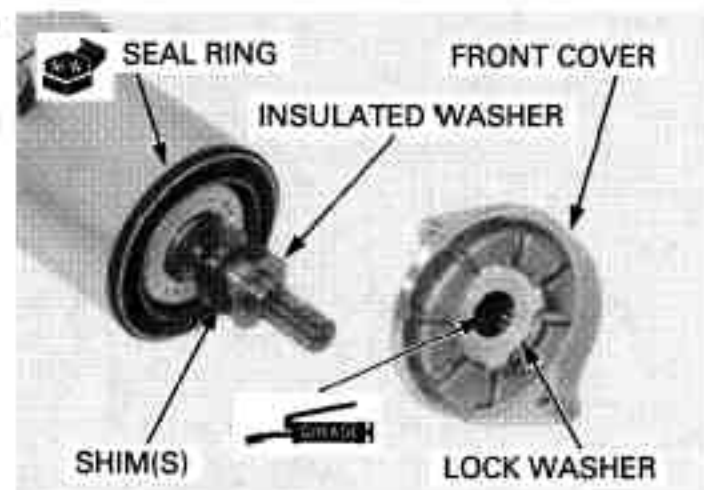

Make sure the index lines are aligned.

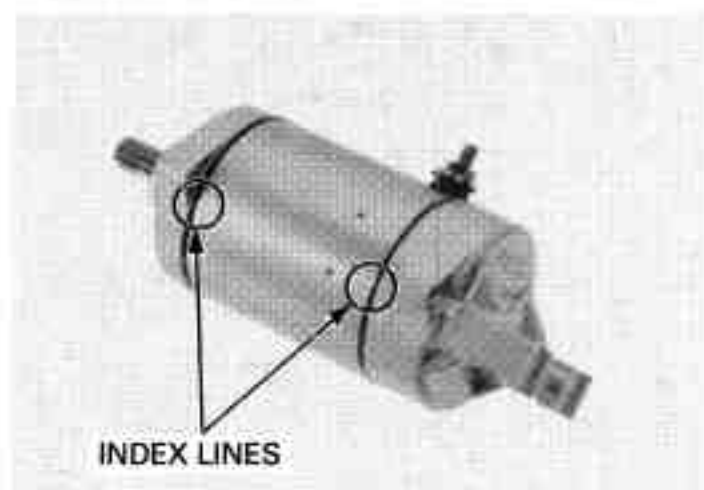

Install and tighten the case bolts securely.

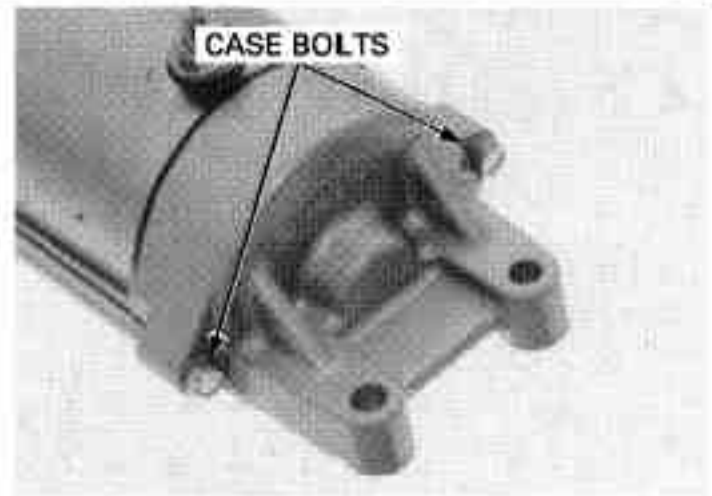

INSTALLATION

Coat a new O-ring with oil and install it into the starter motor groove.



Install the starter motor into the crankcase.

Route the ground cable properly.

Install the EVAP canister purge valve stay (California type).

Install the ground cable and mounting bolts, and tighten the bolts securely.

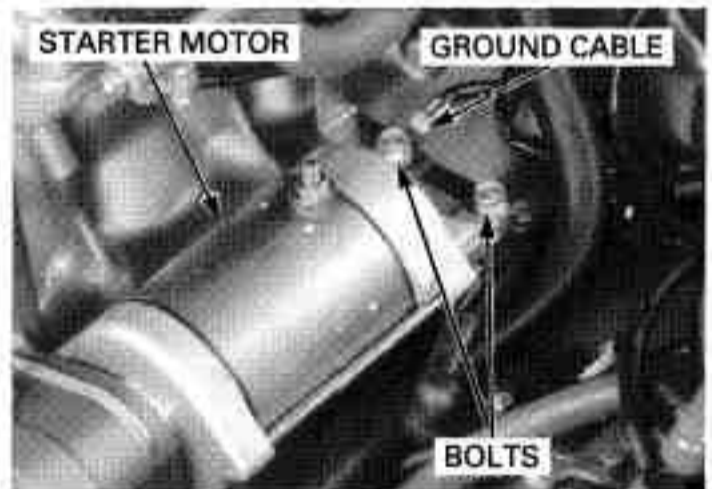

Route the starter motor cable properly.

Install the starter motor cable, then tighten the terminal nut to the specified torque.

TORQUE: 10 N·m (1.0 kgf·m, 7 lbf·ft)

Install the rubber cap securely.

Install the EVAP canister purge valve (California type).

Install the air cleaner housing (page 6-8).

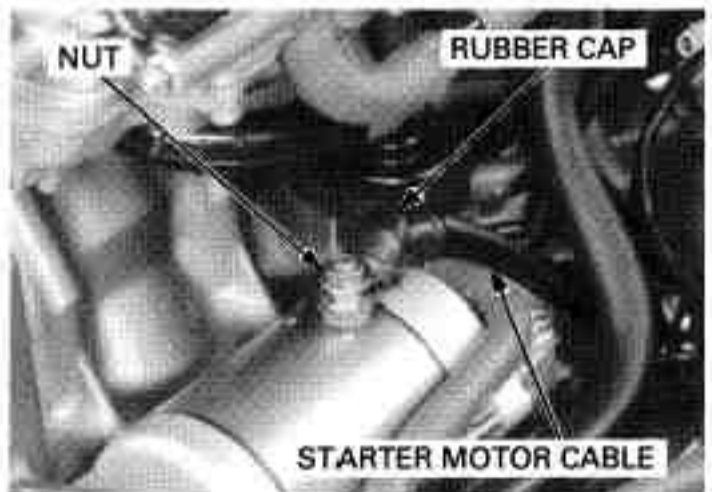

STARTER RELAY SWITCH

OPERATION INSPECTION

Remove the right side cover (page 3-4).

Shift the transmission into neutral.

Turn the ignition switch ON and engine stop switch to RUN.

The coil is normal if the starter relay switch "CLICKS".

If you don't hear the switch "CLICK", inspect the relay switch using the procedure next page.

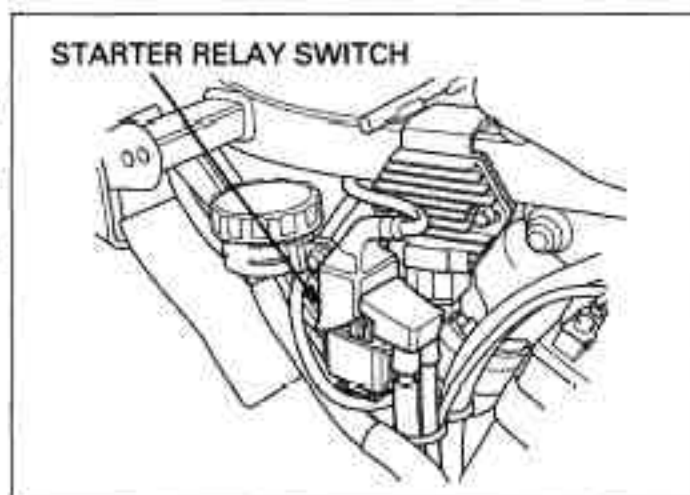

GROUND LINE INSPECTION

Disconnect the starter relay switch 4P connector.

Check for continuity between the Green/red wire (ground line) and ground.

If there is continuity when the transmission is in neutral or when the clutch is disengaged and the side stand switch is retracted, the ground circuit is normal (In neutral, there is a slight resistance due to the diode).

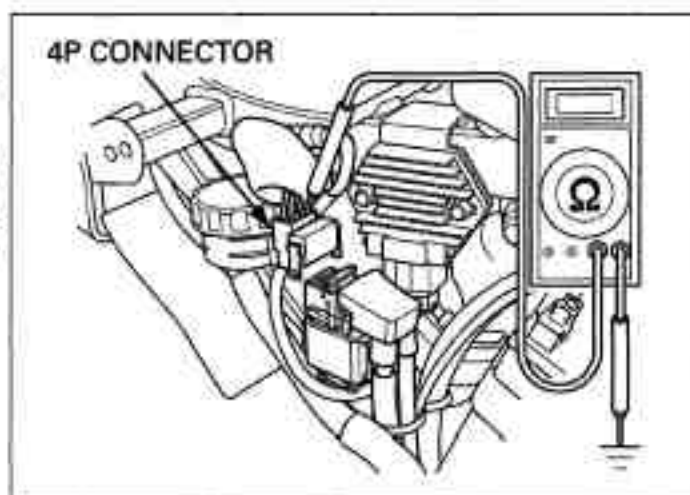

STARTER RELAY VOLTAGE INSPECTION

Connect the starter relay switch 4P connector.

Shift the transmission into neutral.

Measure the voltage between the Yellow/red wire terminal (+) and ground (-).

If the battery voltage appears only when the starter switch is pushed with the ignition switch ON and engine stop switch at RUN, it is normal.

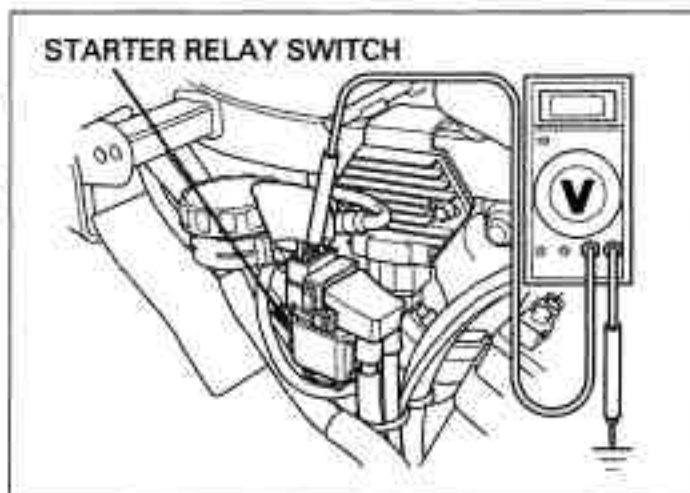

CONTINUITY INSPECTION

Disconnect the 4P connector, battery (+) cable and starter motor cable from the starter relay switch. starter relay cables.

Connect a fully charged 12 V battery positive wire to the relay switch Yellow/red wire terminal and negative wire to the Green/red wire terminal.

Connect an ohmmeter to the starter relay switch large terminals.

There should be continuity between the cable terminals when the battery is connected and no continuity when the battery is disconnected.

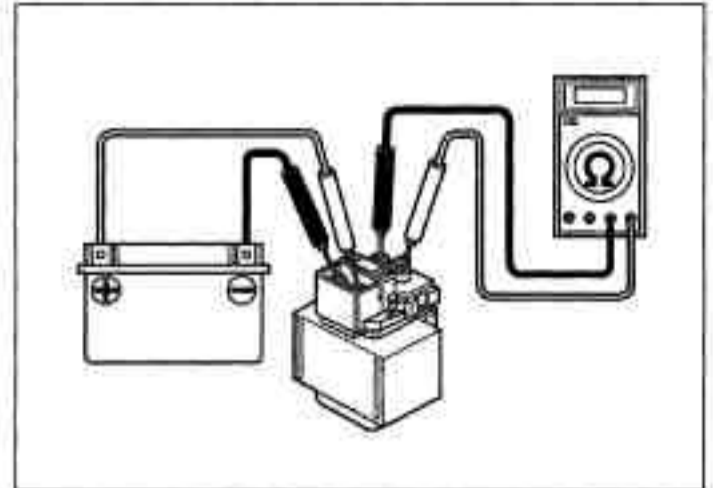
**REMOVAL/INSTALLATION**

Remove the right side cover (page 3-4).

Disconnect the starter relay switch 4P connector. Remove the bolts and disconnect the starter relay cables.

Remove the starter relay switch from the stay.

Installation is in the reverse order of removal.

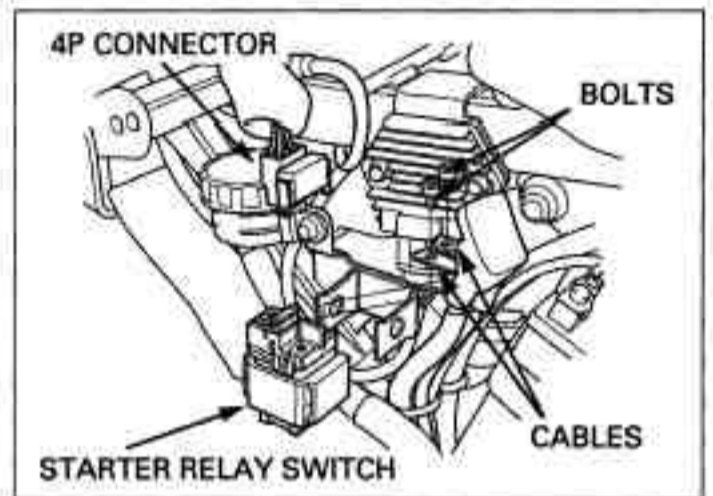
**DIODE****REMOVAL**

Remove the left side cover (page 3-4).

Open the fuse box and remove the diode.

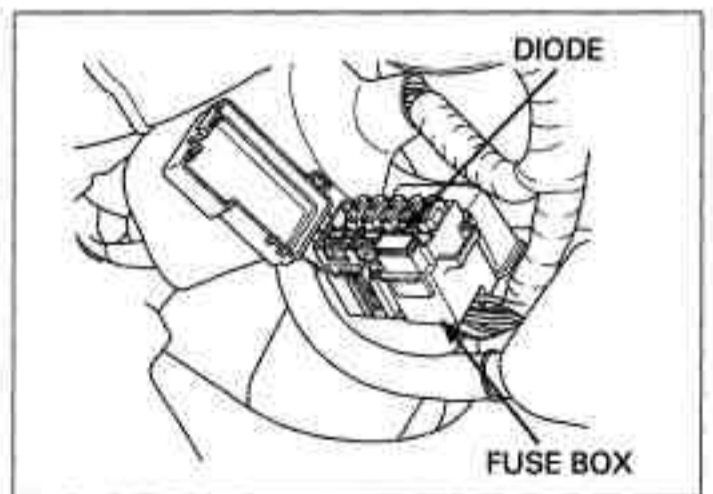

ELECTRIC STARTER

INSPECTION

Check for continuity between the diode terminals. When there is continuity, a small resistance value will register.

If there is continuity, in one direction, the diode is normal.

INSTALLATION

Install the diode in the reverse order of removal.

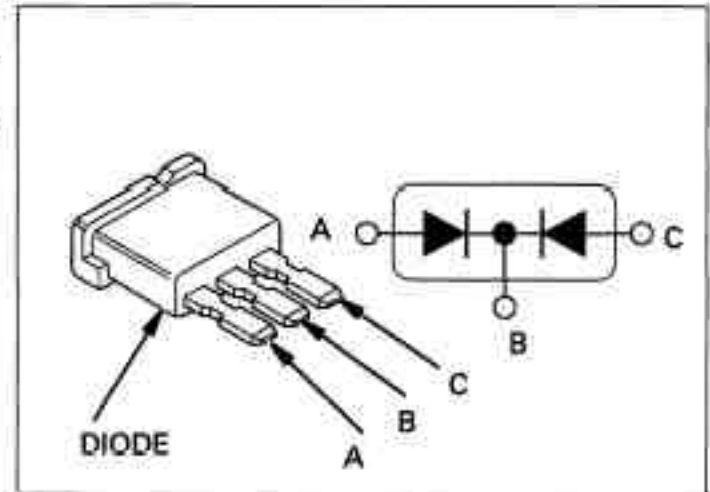

20. LIGHTS/METERS/SWITCHES

SYSTEM LOCATION.....	20-2	OIL PRESSURE SWITCH.....	20-22
SERVICE INFORMATION	20-3	FUEL RESERVE SENSOR ('04 model)	20-23
TROUBLESHOOTING.....	20-5	FUEL LEVEL INDICATOR (After '04 model)	20-24
HEADLIGHT.....	20-6	FUEL LEVEL SENSOR (After '04 model) ..	20-25
TURN SIGNAL	20-7	IGNITION SWITCH	20-26
TAIL/BRAKE LIGHT	20-8	HANDLEBAR SWITCHES.....	20-27
LICENSE LIGHT.....	20-9	BRAKE LIGHT SWITCH	20-28
COMBINATION METER ('04 model)	20-9	CLUTCH SWITCH	20-28
COMBINATION METER (After '04 model)	20-13	NEUTRAL SWITCH.....	20-29
SPEEDOMETER/VEHICLE SPEED SENSOR.....	20-15	SIDE STAND SWITCH.....	20-29
TACHOMETER	20-18	HORN	20-30
COOLANT TEMPERATURE GAUGE/SENSOR	20-19	TURN SIGNAL RELAY.....	20-31
COOLING FAN MOTOR SWITCH	20-21	HEADLIGHT RELAY.....	20-31

SYSTEM LOCATION

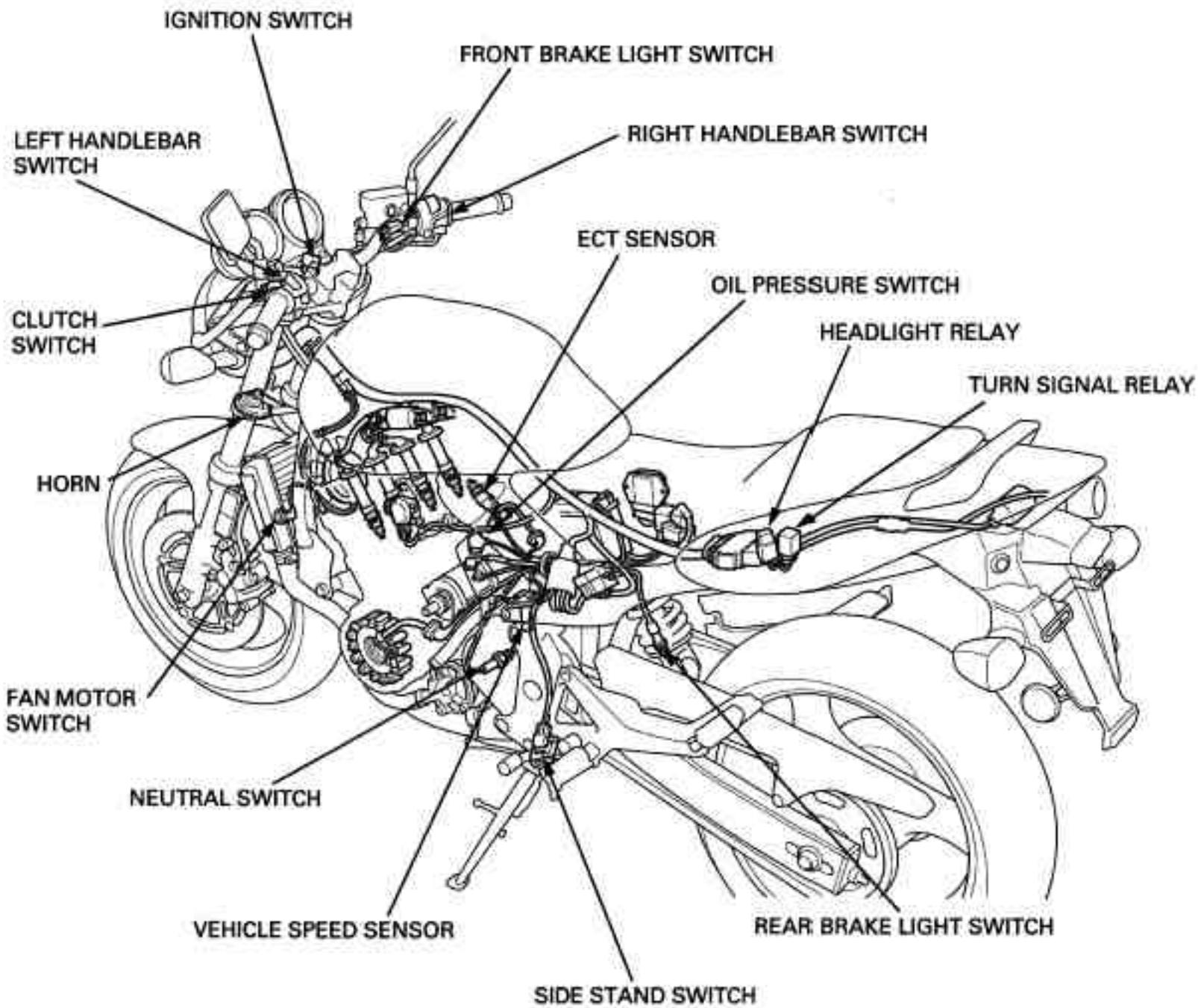

SERVICE INFORMATION

GENERAL

- A halogen headlight bulb becomes very hot while the headlight is ON, and remain hot for a while after it is turned OFF. Be sure to let it cool down before servicing.
- Use an electric heating element to heat the water/coolant mixture for the fan motor switch inspection. Keep flammable materials away from the electric heating element. Wear protective clothing, insulated gloves and eye protection.
- Note the following when replacing the halogen headlight bulb.
 - Wear clean gloves while replacing the bulb. Do not put finger prints on the headlight bulb, as they may create hot spots on the bulb and cause it to fail.
 - If you touch the bulb with your bare hands, clean it with a cloth moistened with alcohol to prevent its early failure.
 - Be sure to install the dust cover after replacing the bulb.
- Check the battery condition before performing any inspection that requires proper battery voltage.
- If the battery terminals were disconnected, the data showing the possible travel distance will be reset. After the connection of battery terminals, the data will be indicated in quotation marks ("---").
- A continuity test can be made with the switches installed on the motorcycle.
- The following color codes are used throughout this section.

Bu = Blue	G = Green	Lg = Light Green	R = Red
Bl = Black	Gr = Gray	O = Orange	W = White
Br = Brown	Lb = Light Blue	P = Pink	Y = Yellow

SPECIFICATIONS ('04 model)

ITEM		SPECIFICATIONS	
Bulbs	Headlight	Hi	12V – 55 W
		Lo	12V – 55 W
	Position light	12V – 8 W X 2	
	Brake/tail light	12V – 21/5 W X 2	
	Turn signal light	Front	12V – 23 W X 2
		Rear	12V – 23 W X 2
	Instrument light	12V – 1.7 W X 2	
	Turn signal indicator	12V – 1.7 W X 2	
	High beam indicator	LED	
	Neutral indicator	LED	
	Oil pressure indicator	LED	
	Low fuel indicator	LED	
Fuse	Main fuse	30 A	
	Sub fuse	20 A X1, 10 A X 4	
Tachometer peak voltage		10.5 V minimum	
Fan motor switch	Start to close (ON)	98 – 102 °C (208 – 216 °F)	
	Stop to open	93 – 97 °C (199 – 207 °F)	

SPECIFICATIONS (After '04 model)

ITEM		SPECIFICATIONS	
Bulbs	Headlight	Hi	12V – 55 W
		Lo	12V – 55 W
	Position light	12V – 8 W X 2	
	Brake/tail light	12V – 21/5 W X 2	
	Turn signal light	Front	12V – 23 W X 2
		Rear	12V – 23 W X 2
	Instrument light	LED	
	Turn signal indicator	LED	
	High beam indicator	LED	
	Neutral indicator	LED	
	Oil pressure /Engine coolant temperature indicator	LED	
	Fuse	Main fuse	30 A
Sub fuse		20 A X 2, 10 A X 4	
Tachometer peak voltage		10.5 V minimum	
Fan motor switch	Start to close (ON)	98 – 102 °C (208 – 216 °F)	
	Stop to open	93 – 97 °C (199 – 207 °F)	

LIGHTS/METERS/SWITCHES

TORQUE VALUES

Oil pressure switch	12 N·m (1.2 kgf·m, 9 lbf·ft)	Apply sealant to the threads
Oil pressure switch terminal screw	2.0 N·m (0.20 kgf·m, 1.4 lbf·ft)	
Neutral switch	12 N·m (1.2 kgf·m, 9 lbf·ft)	
Ignition switch mounting bolt	25 N·m (2.5 kgf·m, 18 lbf·ft)	
ECT sensor	23 N·m (2.3 kgf·m, 17 lbf·ft)	
Fan motor switch	18 N·m (1.8 kgf·m, 13 lbf·ft)	Apply sealant to the threads
License light screw	1.7 N·m (0.17 kgf·m, 1.2 lbf·ft)	
Tail light screw	1.7 N·m (0.17 kgf·m, 1.2 lbf·ft)	

TOOLS

Peak voltage adaptor
07HGJ-0020100 (not available in
U.S.A.)



with commercially available digital
multimeter (impedance 10 M Ω /DCV
minimum)

Ignition Mate peak voltage tester
MTP07-0286 (U.S.A. only)



TROUBLESHOOTING

SPEED SENSOR/SPEEDOMETER

The odometer/trip meter operates normally, but the speedometer does not operate
Faulty speedometer

The speedometer operates normally, but the odometer/trip meter does not operate
Faulty odometer/trip meter

The speedometer operation is abnormal

1. Fuse Inspection

Check for blown main fuse or sub fuse.

Did the fuse blow?

YES – Replace the fuse

NO – GO TO STEP 2.

2. Battery Inspection

Make sure the battery is fully charged and in good condition.

Is the battery in good condition?

YES – Replace the fuse

NO – GO TO STEP 3.

3. Speed Sensor Power Input Voltage Inspection (Speed Sensor Side)

Check for loose or poor contact of the speed sensor 3P (Natural) connector.

With the ignition switch ON and measure the voltage at the speed sensor connector.

Is there Battery Voltage?

NO – • Loose or poor contact of related terminals

- Open circuit in Black/brown or Green/black wires between the battery and speed sensor

YES – GO TO STEP 4.

4. Speed Sensor Power Input Voltage Inspection (Combination Meter Side)

Check for loose or poor contact of the combination meter multi-connectors.

With the ignition switch ON and measure the voltage at bottom of the speedometer terminals.

Is there Battery Voltage?

NO – • Loose or poor contact of related terminals

- Open circuit in Black/brown or Green/black wires between the battery and speed sensor

YES – GO TO STEP 5.

5. Speed Sensor Signal Line Inspection

With the ignition switch OFF, check for continuity of the Pink/green wire between the terminals of the speed sensor and speedometer.

Is there continuity?

NO – Open circuit in Pink/green wire

YES – GO TO STEP 6.

6. Speed Sensor Signal Inspection

Support the motorcycle using a hoist or other support to rise the rear wheel off the ground.

Measure the output voltage (sensor signal) at the speedometer with the ignition switch is ON while slowly turning the rear wheel by your hand.

CONNECTION: Pink (+) – Green (-)

STANDARD: Repeat 0 to 5 V

Is the voltage as specified?

NO – • Faulty speed sensor

- Loose speed sensor mounting bolts

YES – Faulty speedometer

HEADLIGHT

BULB REPLACEMENT

Remove the screws and headlight unit.

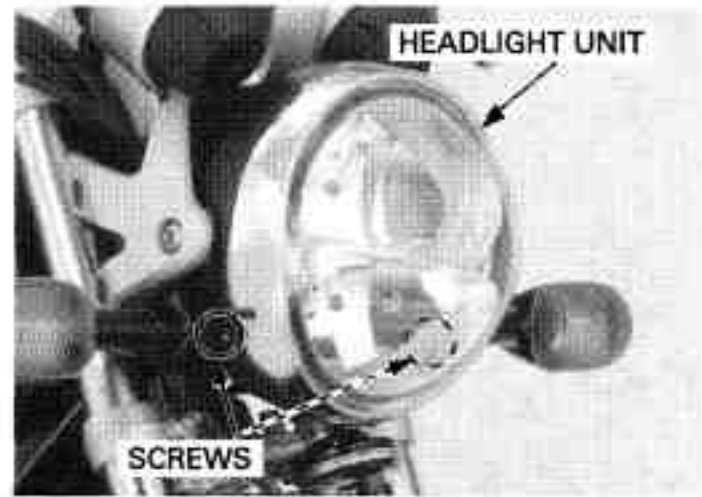

Disconnect the headlight bulb sockets from the head light bulbs.

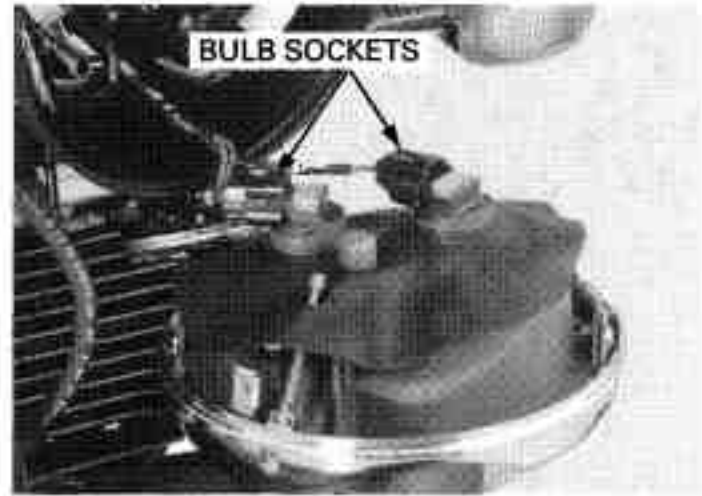

Avoid touching halogen headlight bulb. Finger prints can create hot spots that cause a bulb to break.

Turn the headlight bulb counterclockwise to remove it and replace with a new one.

If you touch the bulb with your bare hands, clean it with cloth moistened with denatured alcohol to prevent early bulb failure.

Install a new headlight bulb aligning its tabs with the groove in the headlight unit. Turn the headlight bulb clockwise and lock it.

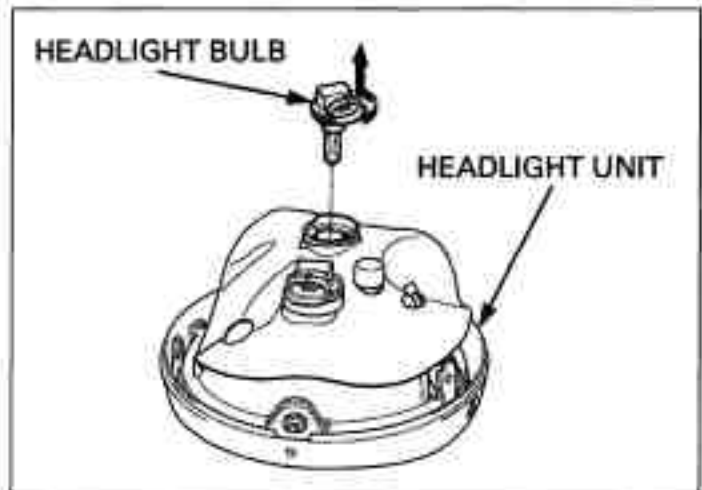

Connect the headlight bulb sockets to the head light bulbs.

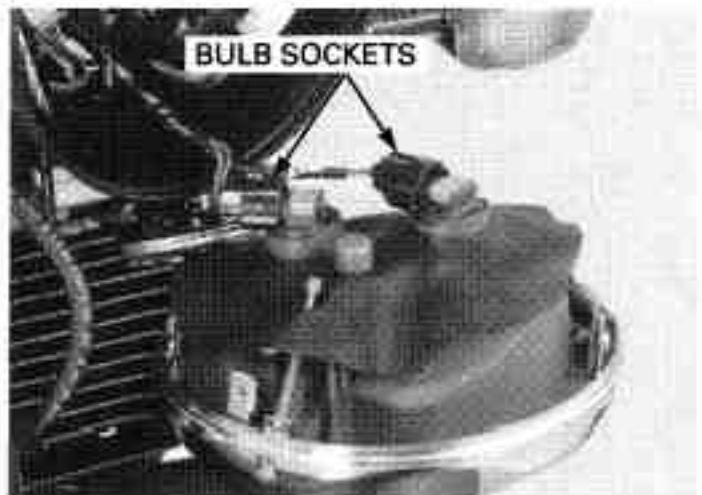

Install the headlight unit.
Install and tighten the screws securely.

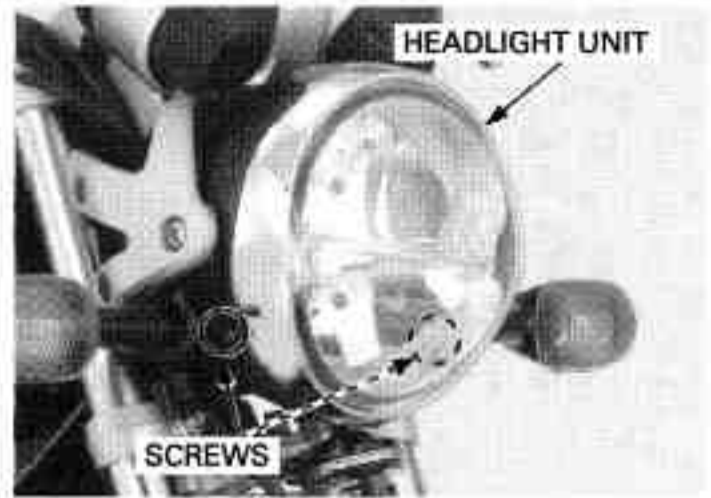

HEADLIGHT CASE REMOVAL/ INSTALLATION

Remove the headlight unit (page 20-6).
Disconnect the connectors and remove the wires
from the headlight case.

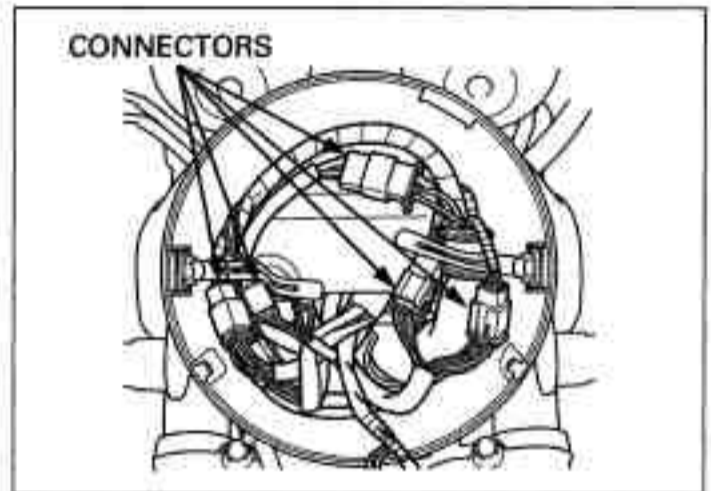

Remove the bolts, special nuts and headlight case.

*Route the wires
properly
(page 1-23).*

Installation is in the reverse order of removal.
Install the headlight unit (page 20-6).
Adjust the headlight aim (page 4-30).

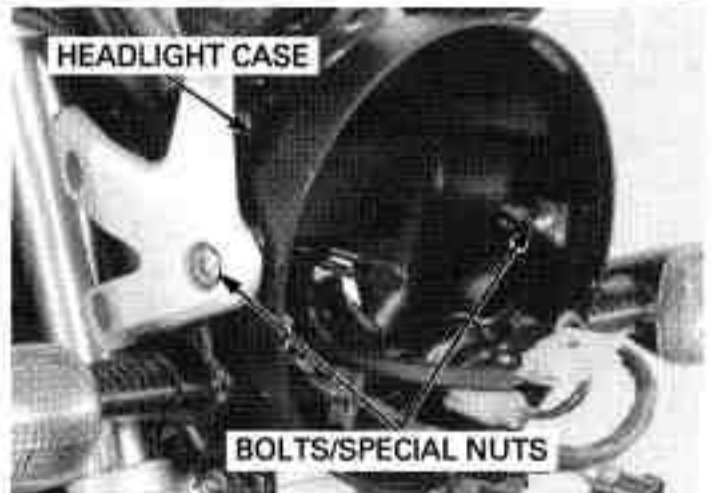

TURN SIGNAL

BULB REPLACEMENT

Remove the screw and turn signal lens.

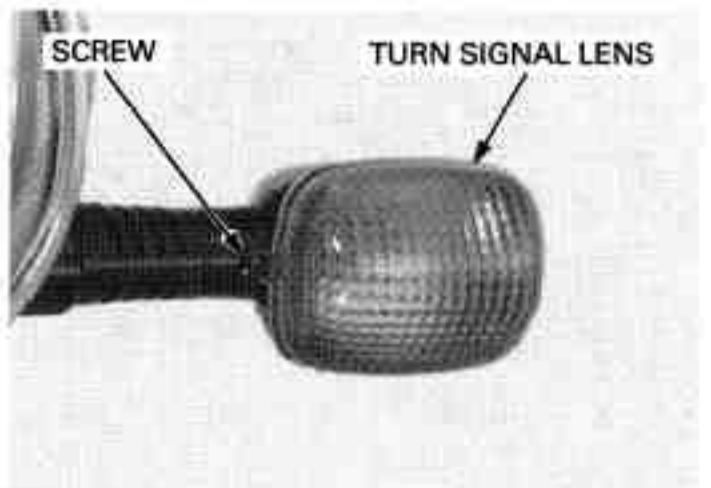

LIGHTS/METERS/SWITCHES

Remove the packing.
While pushing in, turn the bulb counterclockwise to remove it and replace with a new one.
Check the packing for fatigue or damage and replace it if necessary.

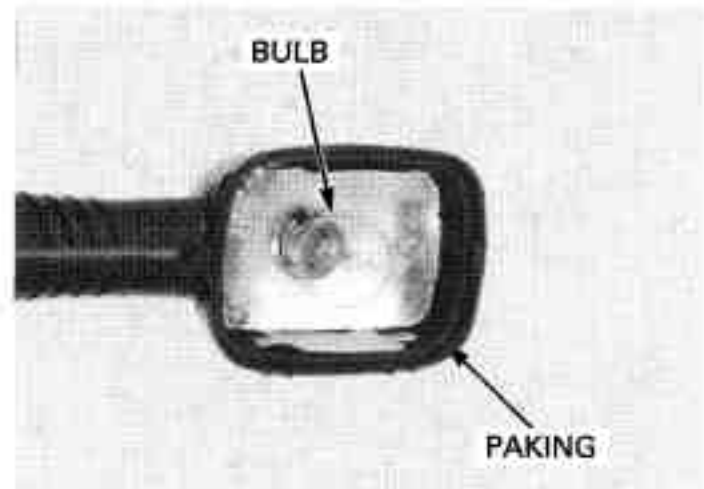

At installation, align the tab of the turn signal unit with the slit of the turn signal lens.
Install the turn signal lens in the reverse order of removal.

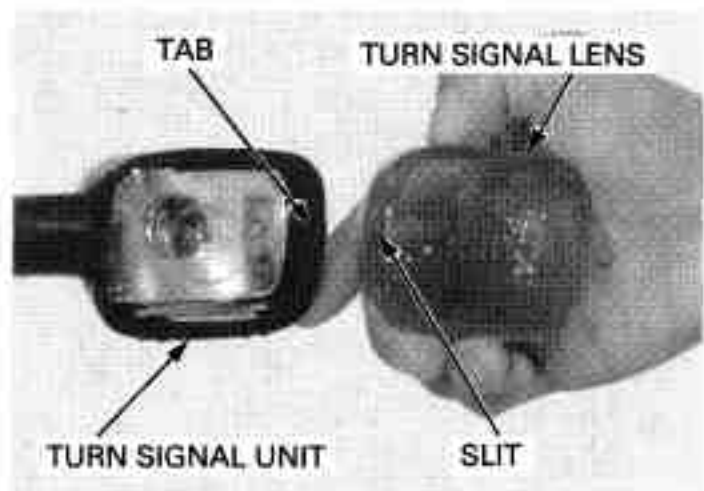

TAIL/BRAKE LIGHT

BULB REPLACEMENT

Remove the screws and tail/brake light lens.

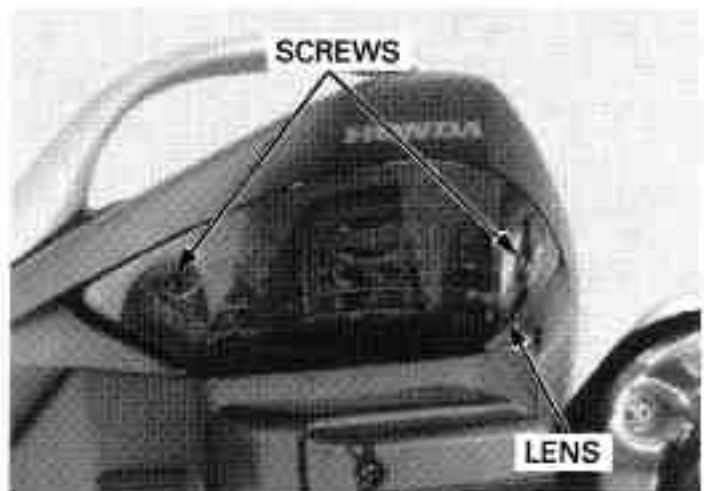

Remove the packing.
While pushing in, the tail/brake light bulb counterclockwise to remove it and replace with a new one.
Check the packing for fatigue or damage and replace it if necessary.

Install the tail/brake light lens in the reverse order of removal.

Tighten the screws to the specified torque.

TORQUE: 1.7 N-m (0.17 kgf-m, 1.2 lbf-ft)

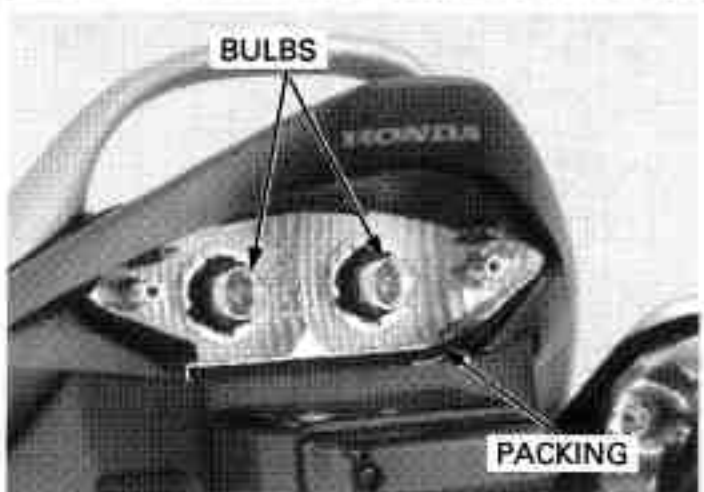

LICENSE LIGHT

BULB REPLACEMENT

Remove the screws and license light case.

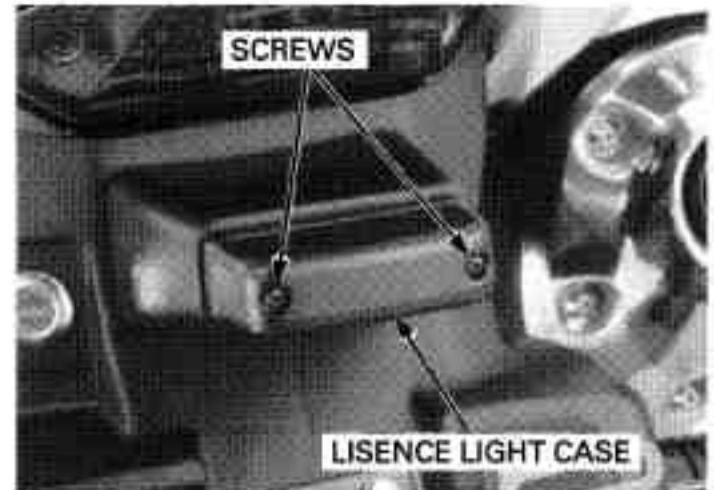

Remove the license light bulb and replace with a new one.

Install the license light case in the reverse order of removal.

Tighten the screws to the specified torque.

TORQUE: 1.7 N·m (0.17 kgf·m, 1.2 lbf·ft)

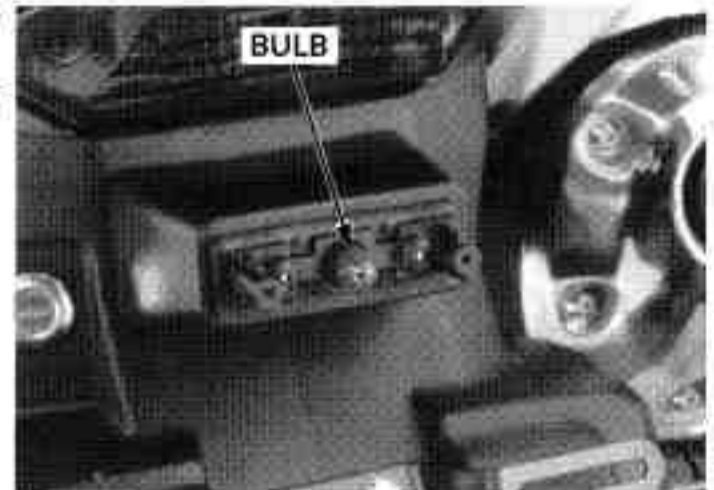

COMBINATION METER ('04 model)

BULB REPLACEMENT

Remove the combination meter (page 20-13) and remove the combination meter lower cover (page 20-10).

Remove the bulb sockets.

Replace the bulb with a new one.

Installation is in the reverse order of removal.

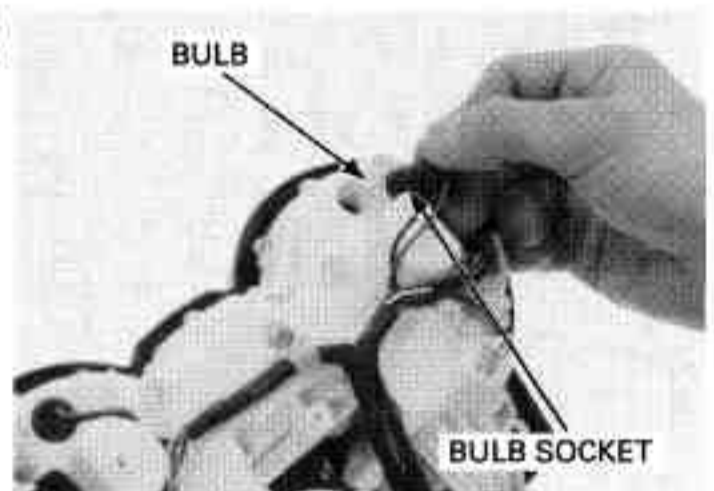

LIGHTS/METERS/SWITCHES

REMOVAL

Remove the headlight unit (page 20-6).

Disconnect the combination meter 6P (Natural) and 9P (Black) connectors.

Remove the headlight case (page 20-7).

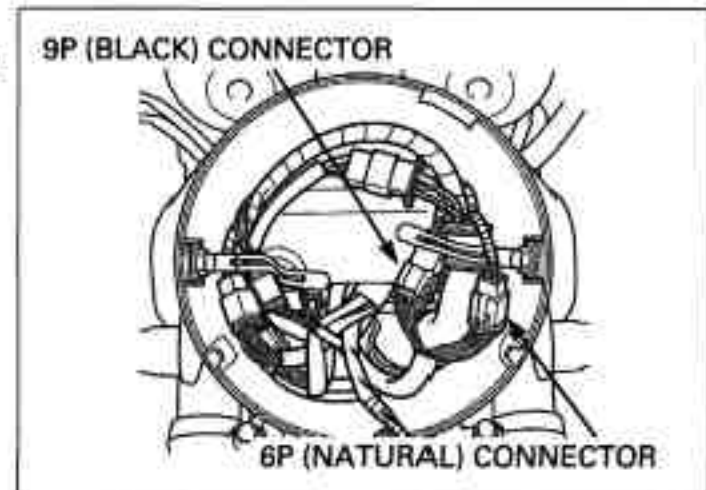

Remove the cap nuts.

Remove the bolts and right/left headlight plates.

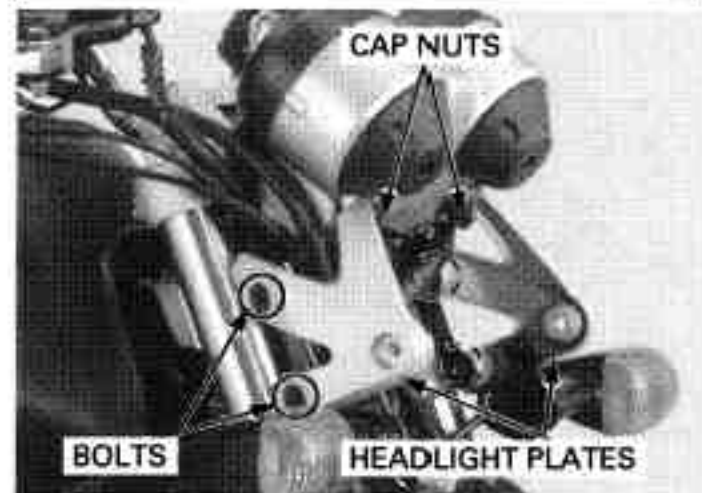

Remove the bolts and combination meter.

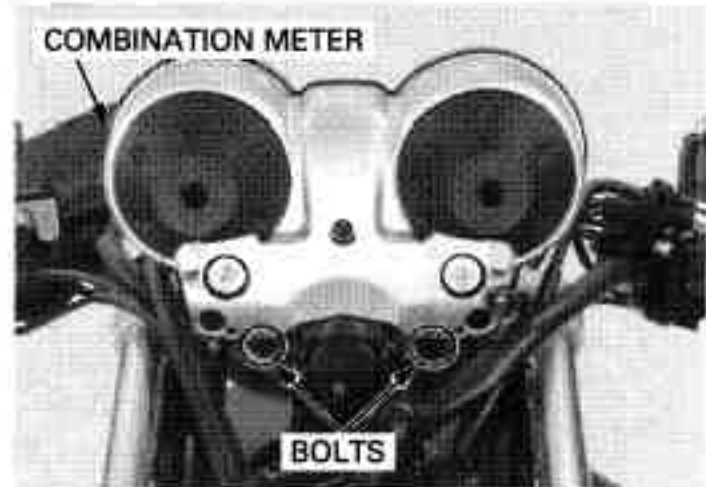

DISASSEMBLY

Remove the screws and lower cover.

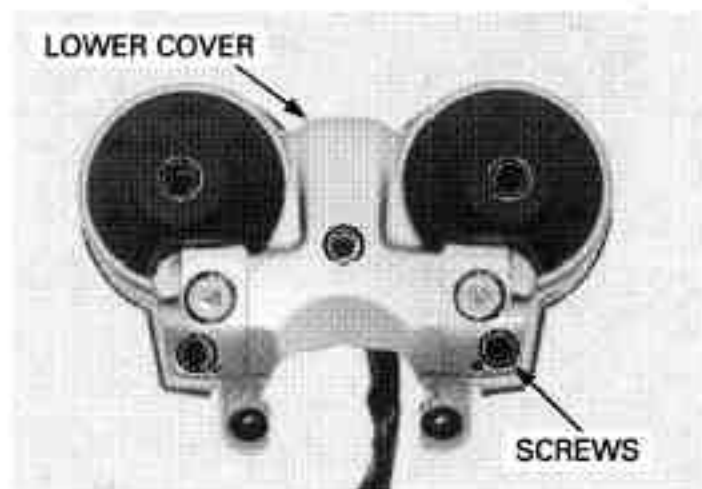

Remove the screws and combination meter front cover.

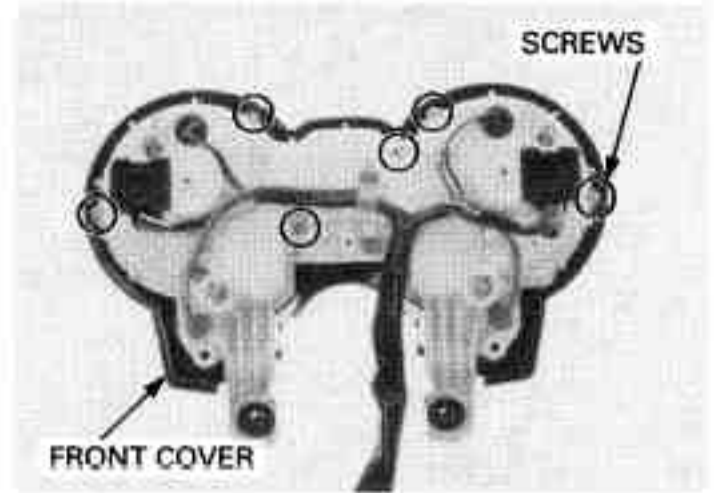

Remove the meter screws.
Remove the bulb sockets.
Remove the screw, clamp and combination meter sub-harness.

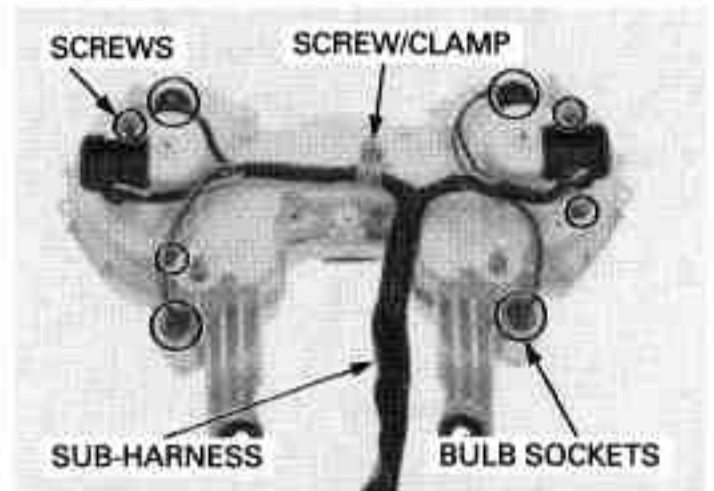

Remove the speedometer, tachometer and indicator plate.

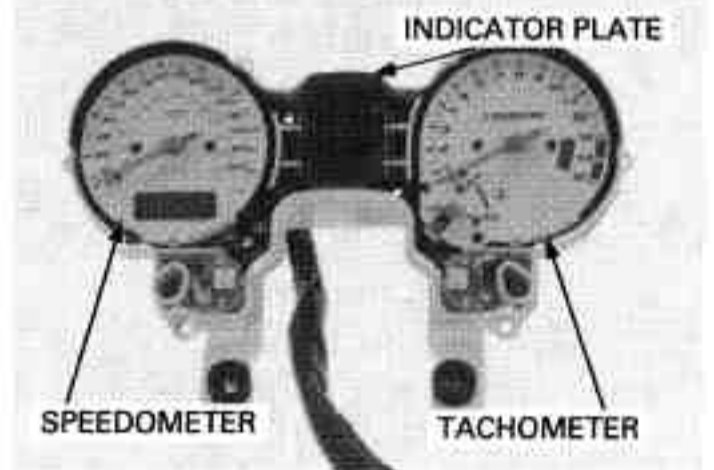

ASSEMBLY

Install the speedometer, tachometer and indicator plate to the combination meter case.

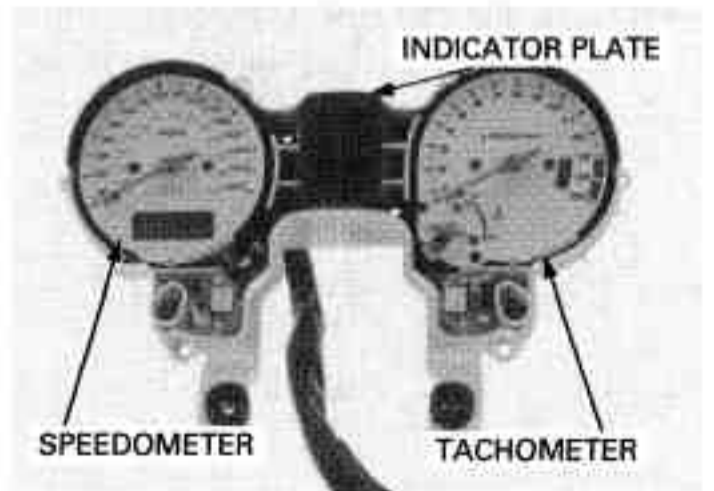

LIGHTS/METERS/SWITCHES

Install the combination meter sub-harness and clamp.
Install and tighten the meter screws and clamp screw securely.
Install the bulb sockets.

Make sure the combination meter sub-harness as shown.

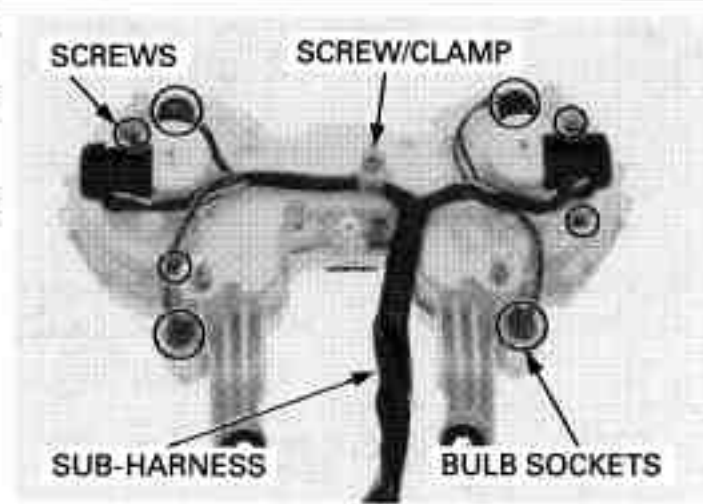

Install the front cover to the combination meter case, then tighten the screws securely.

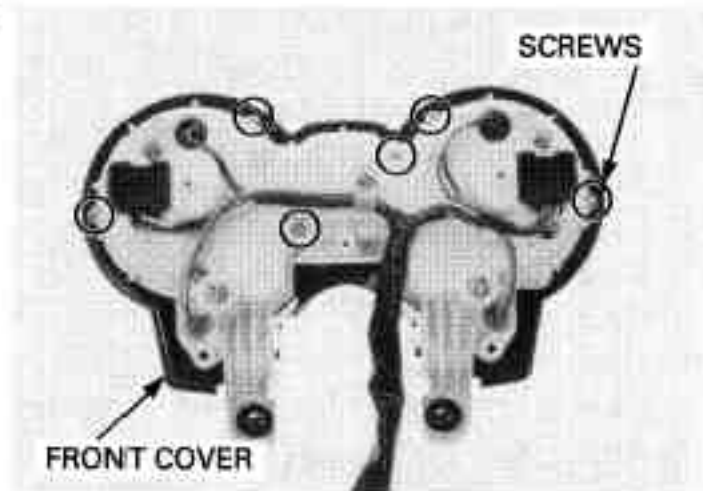

Install the lower cover to the combination meter case, then tighten the screws securely.

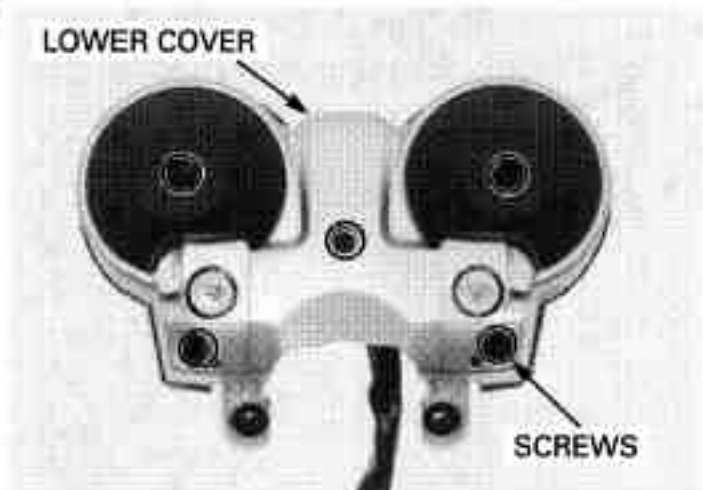

INSTALLATION

Install the combination meter.
Install and tighten the bolts securely.

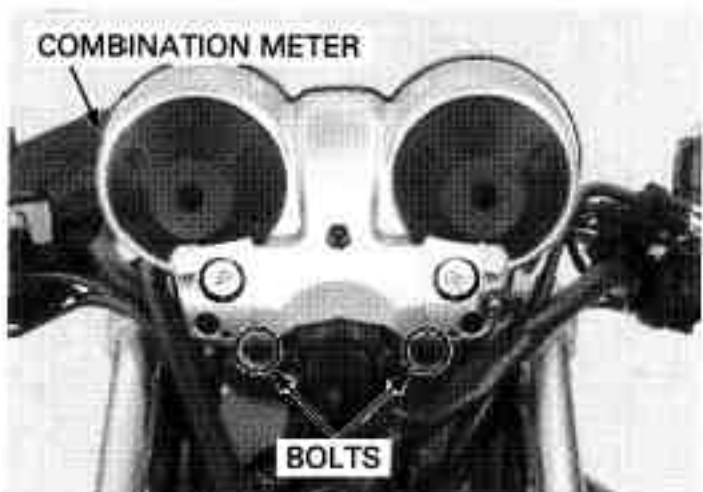

Install the right/left headlight plates to the bracket aligning the its groove with the grommet on the combination meter.

Install and tighten the cap nuts securely.

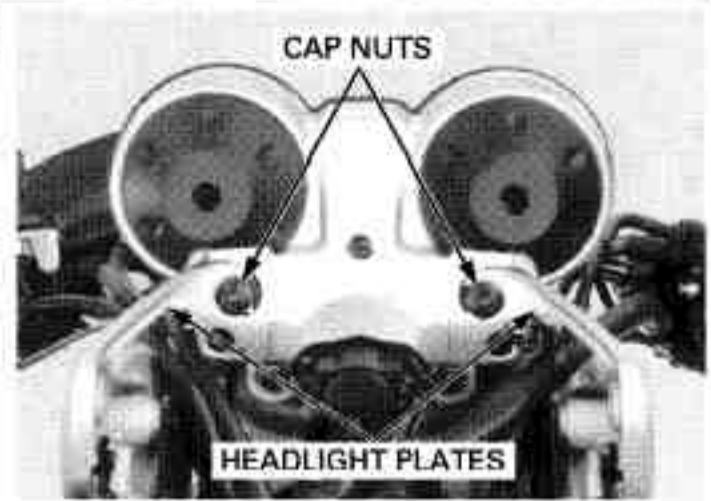

Install and tighten the headlight plate bolts securely.
Install the headlight case (page 20-7).

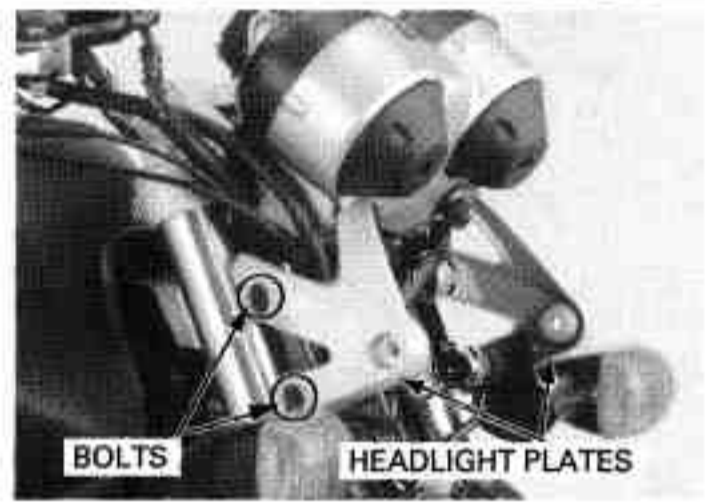

Route the combination meter wires properly (page 1-23).

Connect the combination meter 6P (Natural) and 9P (Black) connectors.
Install the headlight unit (page 20-6).

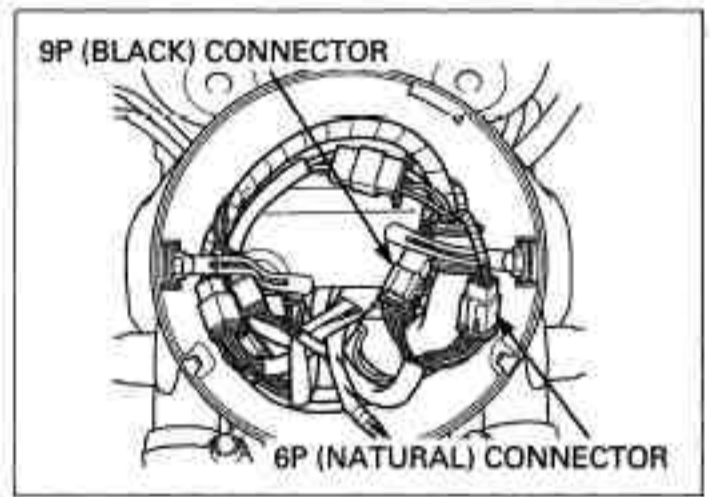

COMBINATION METER (After '04 model)

REMOVAL/INSTALLATION

- Remove the headlight unit.
- Remove the headlight case (page 20-7).
- Remove the meter visor (page 3-8).
- Remove two screws.

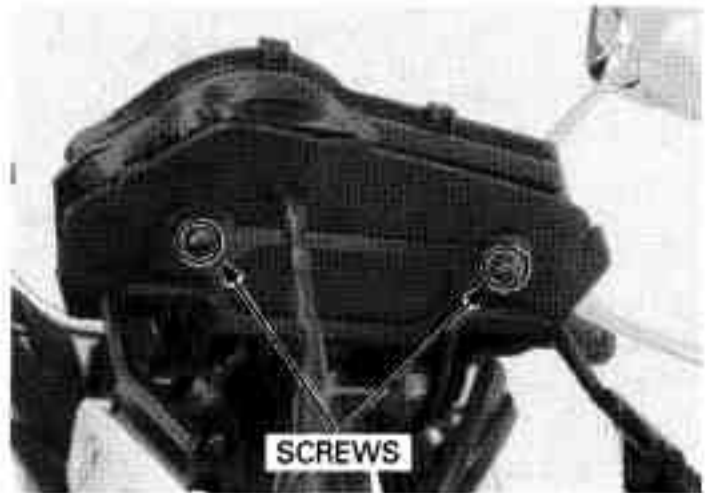

LIGHTS/METERS/SWITCHES

Remove the bolts and the combination meter.

Install the combination meter in the reverse order of the removal.

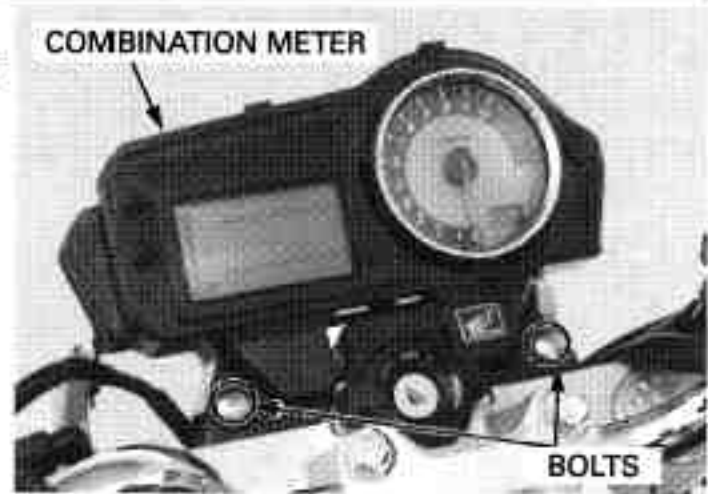

DISASSEMBLY/ASSEMBLY

Remove 10 screws (3 x 16 mm) and two screws (3 x 12 mm).

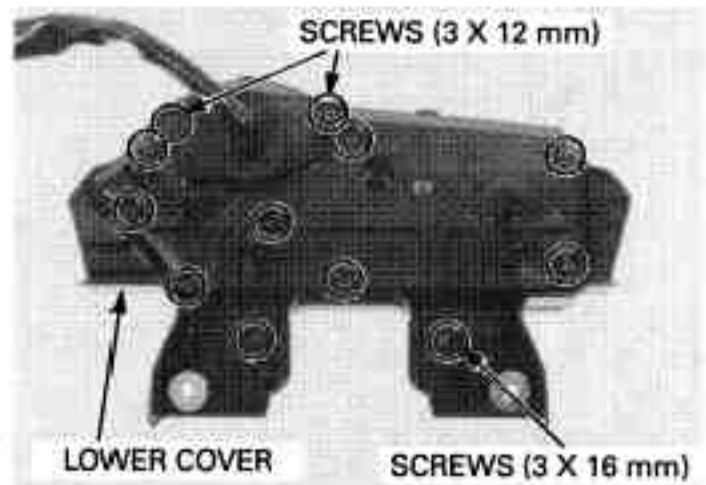

Disassemble the combination meter to the upper, lower case and the meter board.

Assemble the combination meter in the reverse order of disassembly.



POWER/GROUND LINE INSPECTION

Disconnect the combination meter 6P (Natural) and 9P (Black) connectors.
Check the following at the wire harness side connector terminals of the combination meter.

Power input line

Measure the voltage between the Black/brown wire terminal (+) and Ground (-).
There should be battery voltage with the ignition switch ON.
If there is no voltage, check for open circuit in Black/brown wire.

Back-up voltage line

Measure the voltage between the Red/green wire terminal (+) and Ground (-).
There should be battery voltage at all times.
If there is no voltage, check for open circuit in Red/green wire.

Ground line

Measure the continuity between the Green/black wire terminal (+) and Ground (-), Green wire terminal (+) and Ground (-).
There should be continuity.
If there is no continuity, check for open circuit in Green/black wire and Green wire.

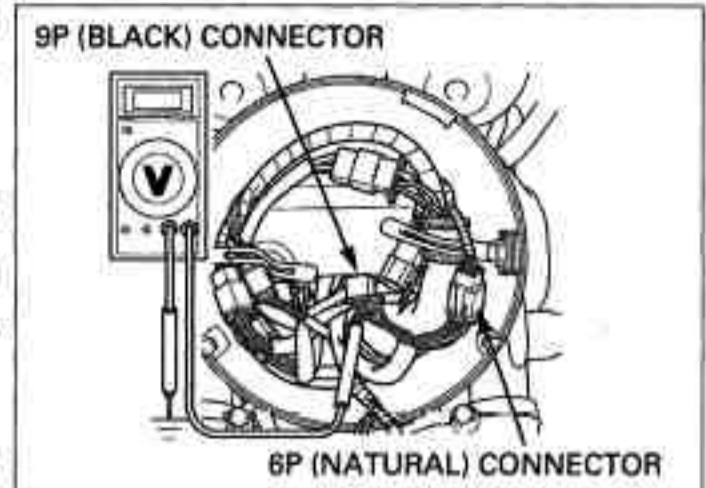

SPEEDOMETER/VEHICLE SPEED SENSOR

SYSTEM INSPECTION

'04 model only: When the ignition switch is turned ON, check that the speedometer needle moves to full scale and then returns to zero.

If the needle does not show initial function, check for combination meter power input line (page 20-15).

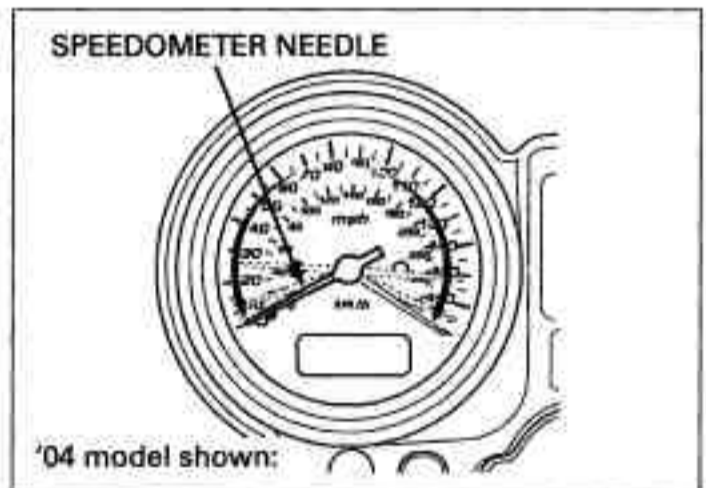

LIGHTS/METERS/SWITCHES

Check that the tachometer and coolant temperature meter function properly.

- If they do not function, perform the power and ground line inspection of the combination meter (page 20-15).
- If they function, shift the transmission into neutral, the combination meter 6P (Natural) and 9P (Black) connectors are connected and turn the ignition switch ON.

Measure the voltage between the Pink/green (+) and Green/black (-) wire terminals of the 9P (Black) connector.

Slowly turn the rear wheel by hand.

There should be 0 to 5 V pulse voltage.

- If pulse voltage appears, replace the speedometer (page 20-10).
- If pulse voltage does not appear, check for open or short circuit in Pink/green wire. If the Pink/green wire is OK, check for the vehicle speed sensor (page 20-16).

VEHICLE SPEED SENSOR INSPECTION

Remove the left side cover (page 3-4).

Disconnect the vehicle speed sensor 3P (Natural) connector and check for loose or poor contact of the connector.

Disconnect the vehicle speed sensor 3P (Natural) connector.

Turn the ignition switch to ON and measure the voltage at the 3P (Natural) connector wire harness side.

CONNECTION: Black/brown (+) – Green/black (-)
STANDARD: Battery voltage

If there is no voltage, check for open circuit in Black/brown and Green/black wire and loosen contact of the wire harness connectors.

Support the motorcycle securely and raise the rear wheel off the ground.

Shift the transmission into neutral.

Connect the vehicle speed sensor 3P (Natural) connector.

Measure the voltage at the sensor connector terminals with the ignition switch is ON while slowly turning the rear wheel by hand.

CONNECTION: Pink/green (+) – Green/black (-)
STANDARD: Repeat 0 to 5V

If the measurement is out of specification, replace the speed sensor.

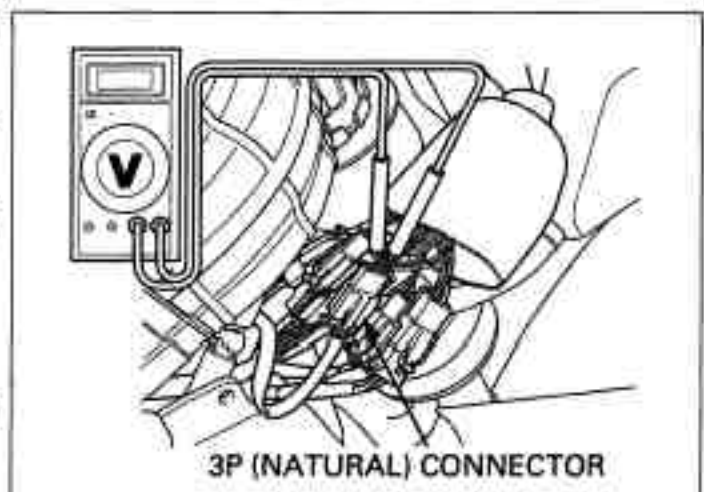
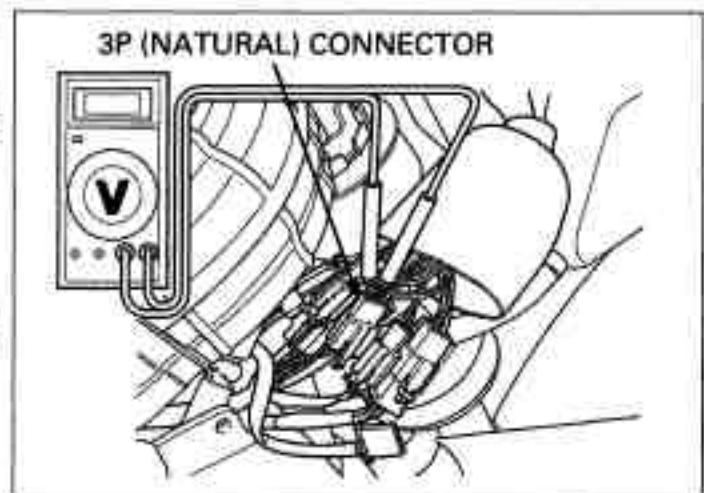
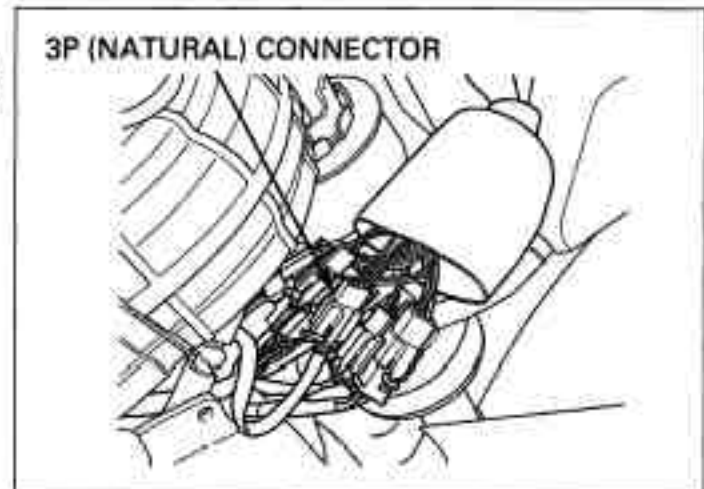
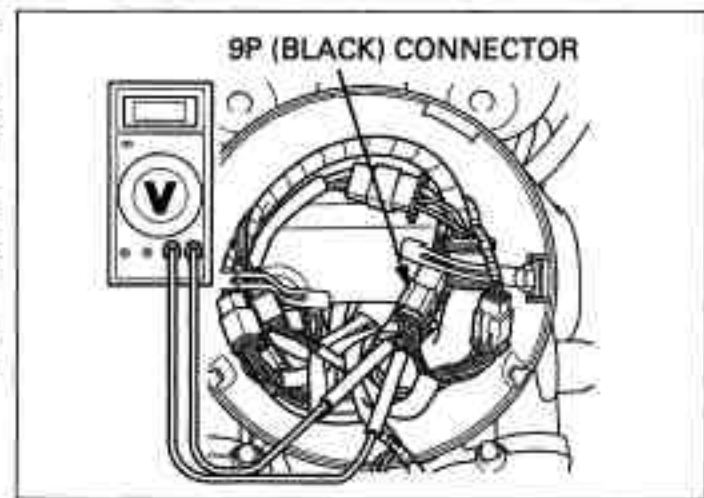

REMOVAL/INSTALLATION

Remove the left side cover (page 3-4).

Disconnect the vehicle speed sensor 3P (Natural) connector.

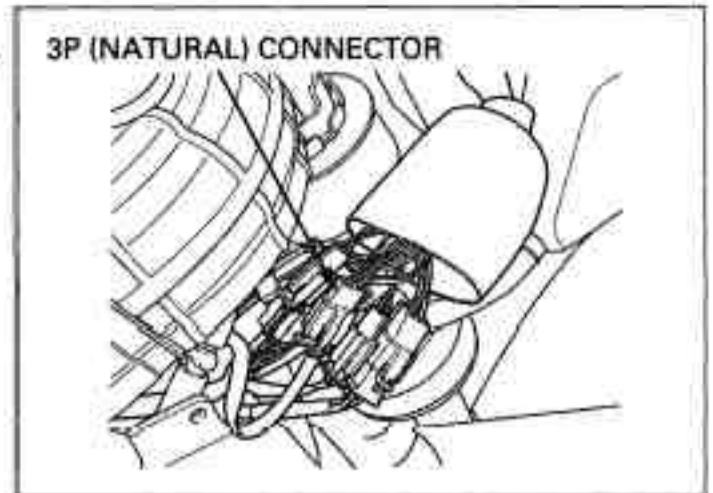

Remove the air cleaner housing (page 6-7).

Remove the wire band.

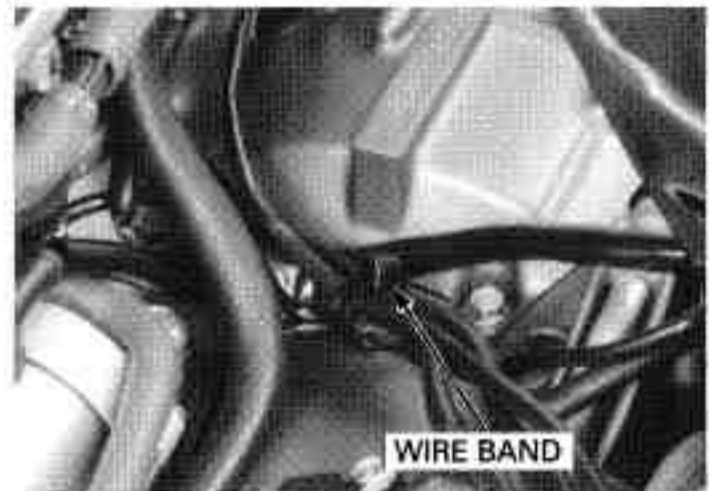

Remove the bolts and vehicle speed sensor.

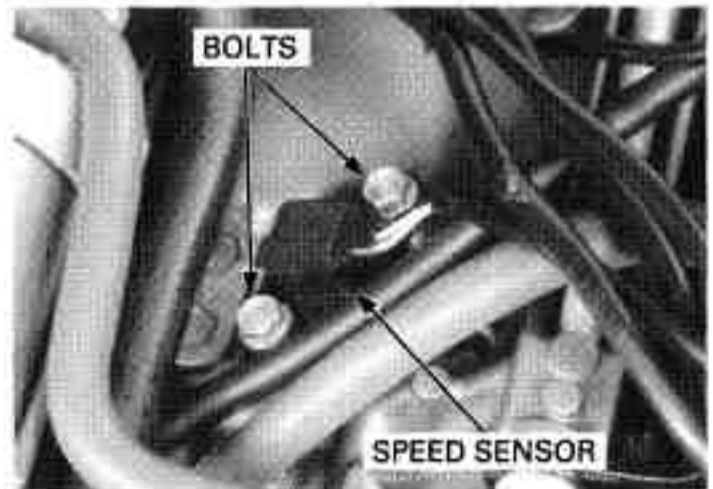

Check the O-ring is in good condition, replace if necessary.

Install the vehicle speed sensor into the upper crankcase.

Installation is in the reverse order of removal.

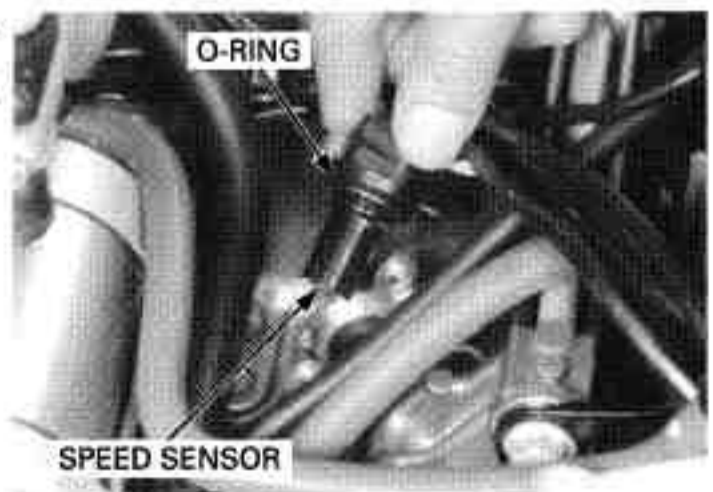

TACHOMETER

SYSTEM INSPECTION

When the ignition switch is turned ON, check that the tachometer needle moves to full scale and then returns to zero.

If the needle does not show initial function, check for combination meter power input line (page 20-15).

'04 model shown:

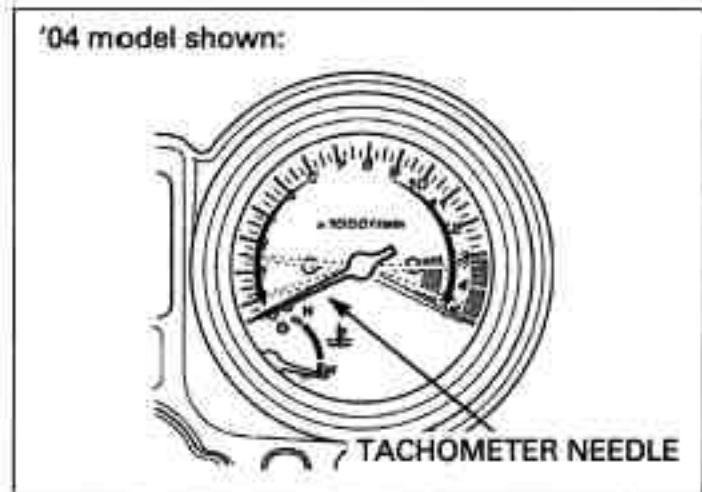

Disconnect the combination meter 9P (Natural) and 9P (Black) connectors (page 20-15). Connect the peak voltage adaptor to the tachometer Yellow/green (+) terminal and Green (-).

TOOLS:

Ignition Mate peak voltage MTP07-0286 (U.S.A. only) tester or Peak voltage adaptor 07HGJ-0020100 (not available in U.S.A.)

with commercially available digital multimedia (impedance 10 MΩ/DCV minimum)

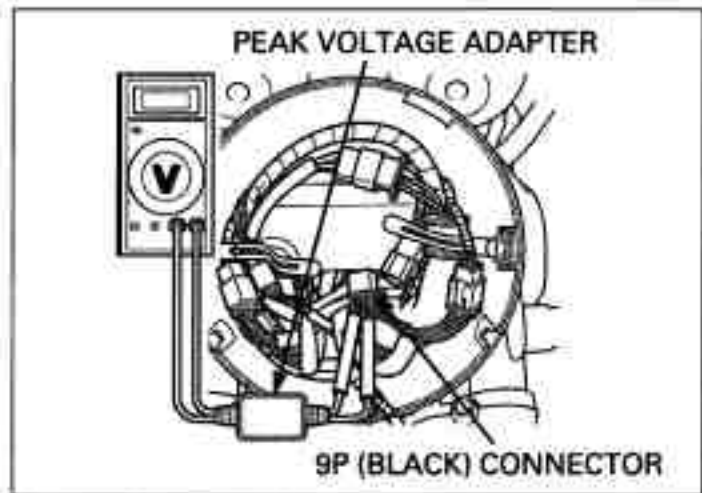

CONNECTION: Yellow/green (+) and Green (-)

Start the engine and measure the tachometer input peak voltage.

PEAK VOLTAGE: 10.5 V minimum

If the value is normal, replace the tachometer. If the measured value is below 10.5 V, replace the ECM.

If the value is 0 V, check for continuity between the combination meter 9P (Black) connectors terminal and the ICM 22P connector Yellow/green terminals. If there is no continuity, check the wire harness and combination meter sub-harness for an open circuit. If there is continuity, replace the tachometer (page 20-10).

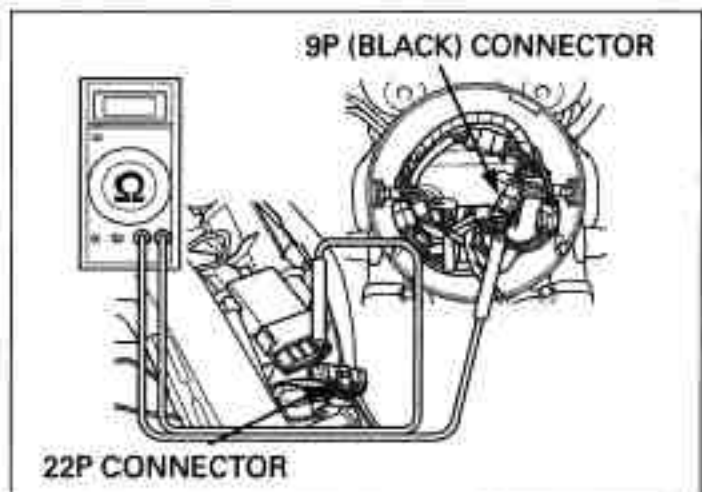

COOLANT TEMPERATURE GAUGE/ SENSOR

SYSTEM INSPECTION

If the engine coolant temperature indicates too high or too low temperature in spite of normal engine coolant temperature, inspect the following.

Disconnect the ECT sensor 3P connector from the sensor.

Ground the Green/blue wire terminal of the ECT sensor 3P connector wire harness side with a jumper wire.

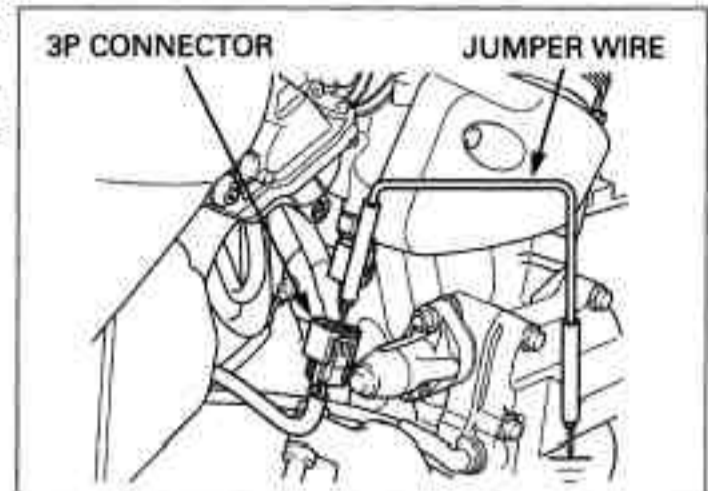

'04 model only: Turn the ignition switch to ON and check the coolant temperature gauge. The coolant temperature gauge needle should move to "H".

If the gauge needle moves, check the ECT sensor unit (page 20-20).

If the gauge needle does not move, check the wire harness for an open or short circuit.

If the wire harness is normal, replace the coolant temperature gauge (page 20-10).

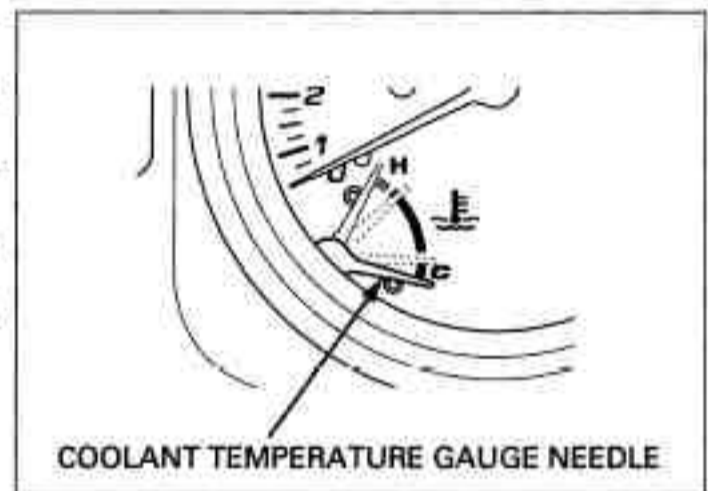

After '04 model only: Turn the ignition switch to ON and check the engine coolant temperature indicator.

- If the engine coolant temperature indicator indicates as over heat (shown in the right illustration), inspect the ECT sensor (page 20-20).
- If the engine coolant temperature indicator does not indicate as shown in the right illustration, check the following.
 - Open circuit in the ECT sensor (Green/blue) wire
 - Faulty combination meter

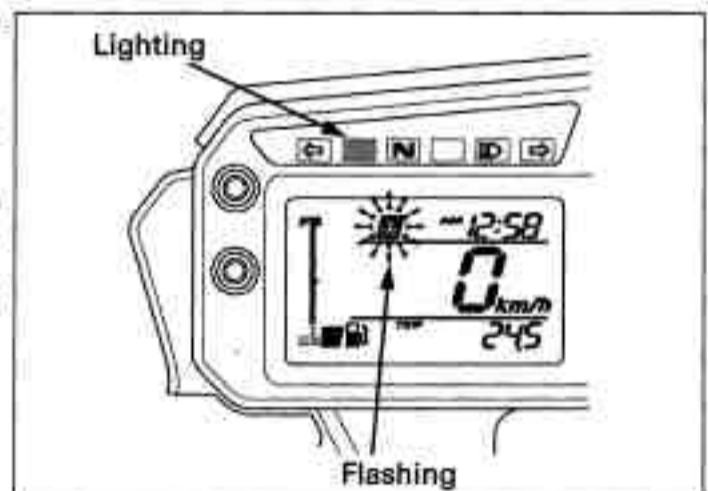

ECT SENSOR UNIT INSPECTION

Drain the coolant (page 7-7).

Disconnect the ECT sensor 3P connector and remove the sensor and sealing washer.

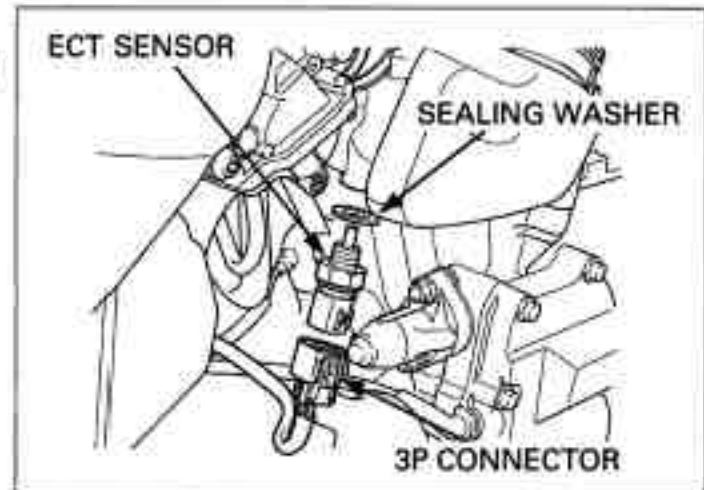

Suspend the ECT sensor in a pan of coolant (1:1 mixture) an electric heating element and measure the resistance through the sensor as the coolant heats up.

- Soak the ECT sensor in coolant up to its threads with at least 40 mm (1.6 in) from the bottom of the pan to the bottom of the sensor.
- Keep the temperature constant for 3 minutes before testing. A sudden change of temperature will result in incorrect readings. Do not let the thermometer or ECT sensor touch the pan.

Replace the sensor if it is out of specification by more than 10% at any temperature listed.

Temperature	80°C (68°F)	120°C (248°F)
Resistance	47.5 - 56.8 Ω	14.9 - 16.1 Ω

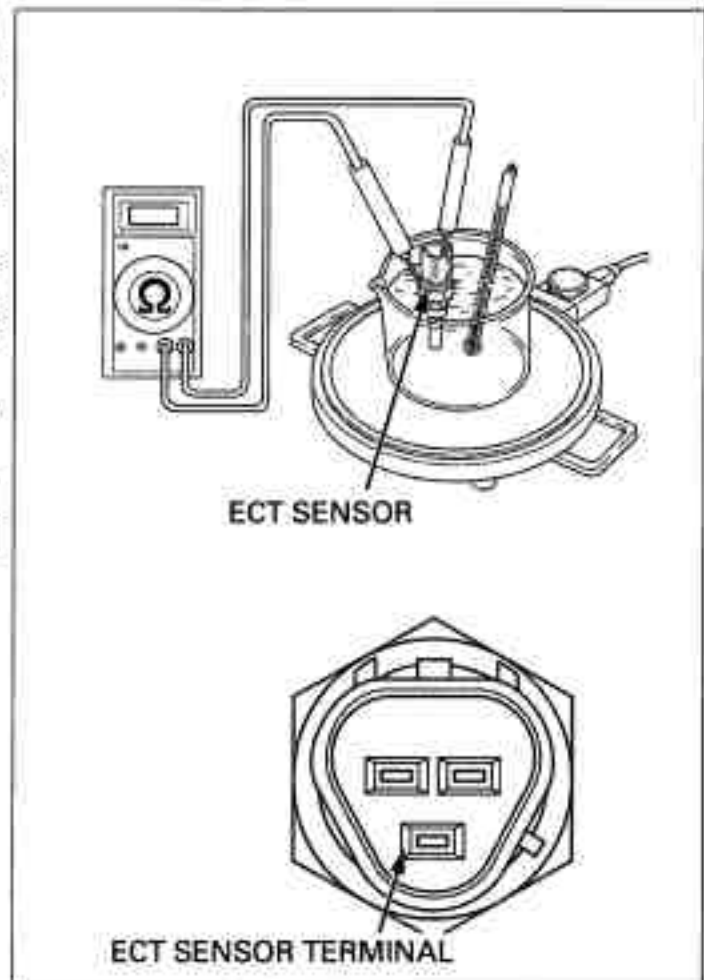

Always replace the sealing washer with a new one.

Install and tighten the ECT sensor to the specified torque.

TORQUE: 23 N·m (2.3 kgf·m, 17 lbf·ft)

Connect the ECT sensor 3P connector.

Fill the system and bleed the air (page 7-7).

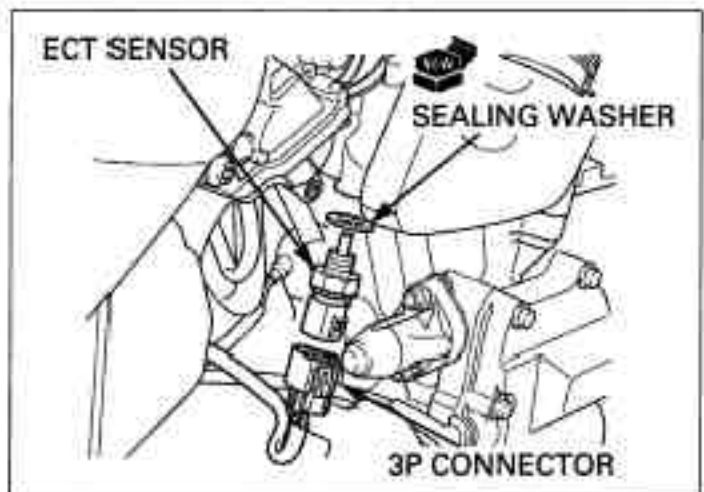

COOLING FAN MOTOR SWITCH

INSPECTION

Check for a blown fuse before inspection.

Fan motor does not stop

Turn the ignition switch to OFF, disconnect the connector from the fan motor switch and turn the ignition switch to ON again.

If the fan motor does not stop, check for a shorted wire between the fan motor and switch.

If the fan motor stops, replace the fan motor switch.

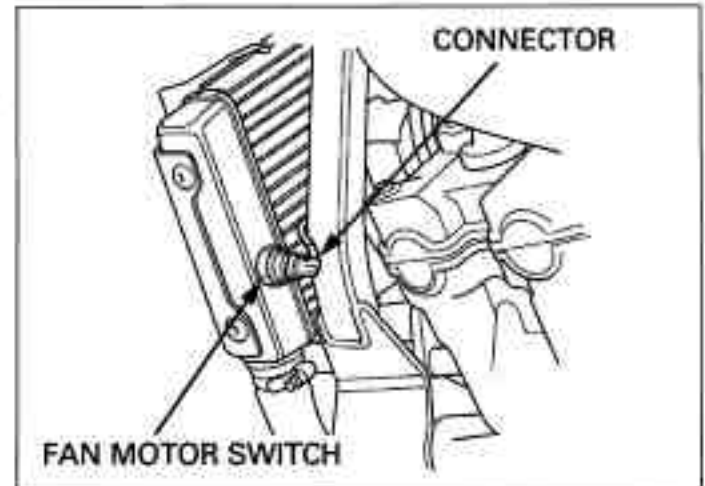

Fan motor does not start

Before testing, warm up the engine to operating temperature.

Disconnect the connector from the fan motor switch and ground the connector to the body with a jumper wire.

Turn the ignition switch to ON and check the fan motor.

If the motor starts, check the connection at the fan motor switch terminal.

If it is OK, replace the fan motor switch.

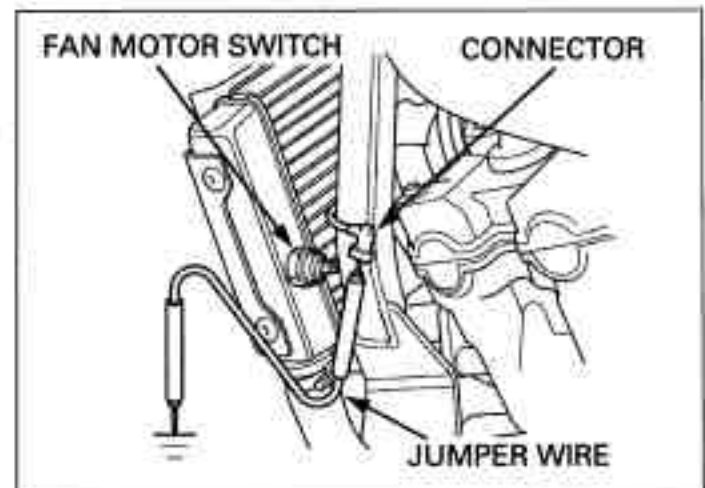

If the motor does not start, check for voltage between the fan motor switch connector and ground.

If battery voltage is measured, replace fan motor.

If there is no battery voltage, check for poor connection of the connector or broken wire harness.

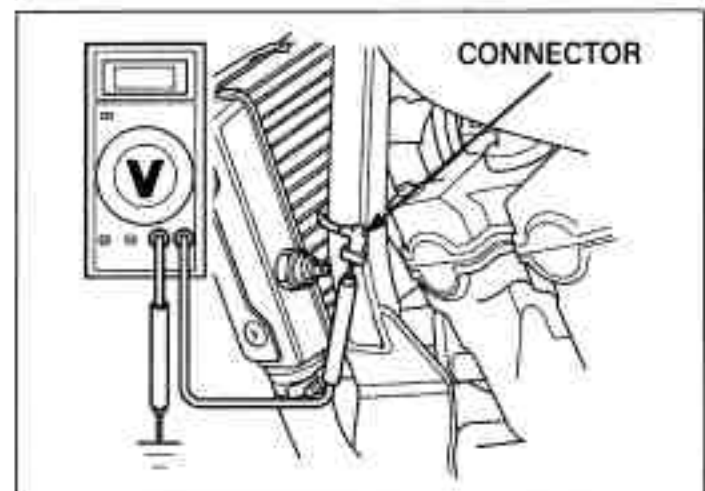

LIGHTS/METERS/SWITCHES

REMOVAL/INSTALLATION

Disconnect the fan motor switch connector and remove the switch.

Install a new O-ring onto the fan motor switch. Apply sealant to the fan motor switch threads. Install and tighten the fan motor switch.

TORQUE: 18 N·m (1.8 kgf·m, 13 lbf·ft)

Install the removed parts in the reverse order of removal.

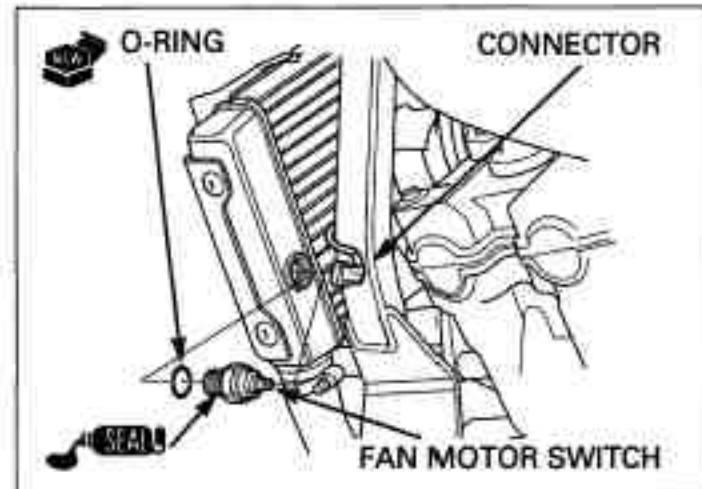

OIL PRESSURE SWITCH

INSPECTION

'04 model only: If the oil pressure warning indicator stays on while the engine running, check the engine oil level before inspection.

Make sure that the oil pressure warning indicator lights with the ignition switch to ON.

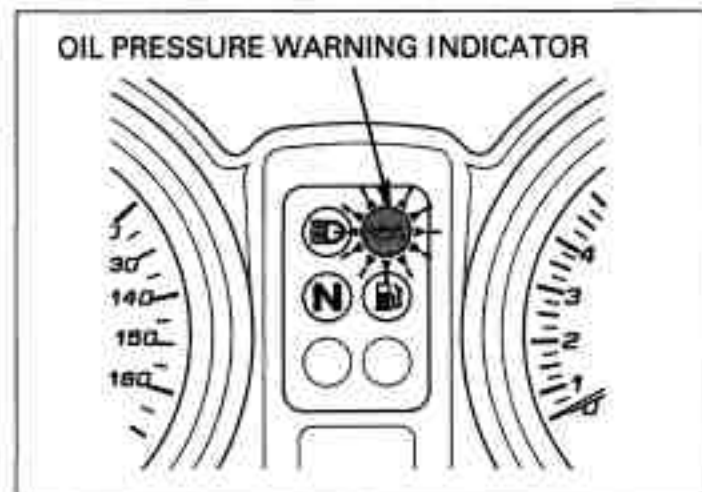

After '04 model only: If the oil pressure warning indicator stays on while the engine running, check the engine oil level before inspection.

Make sure if the engine oil pressure indicator indicates the right illustration.

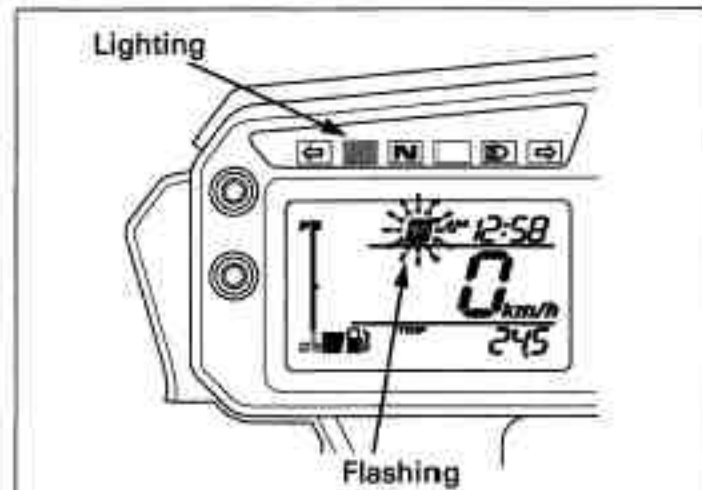

If the indicator does not light, inspect as follow:
Remove the rubber cap.
Remove the screw and oil pressure switch terminal.

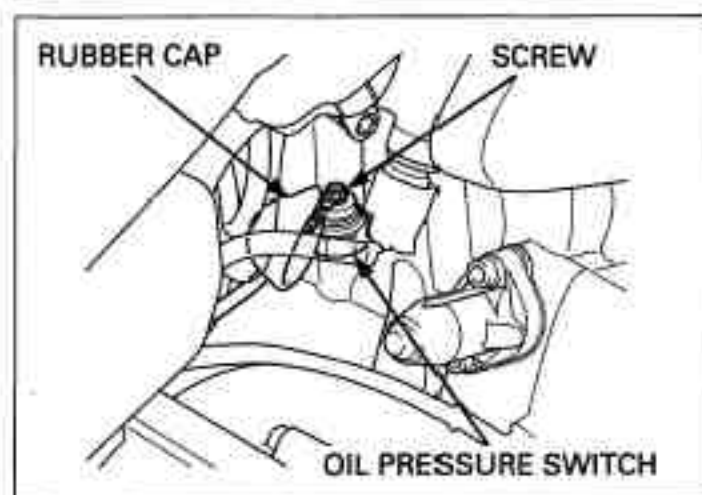

Short the oil pressure switch wire terminal with the ground using a jumper wire.

The oil pressure warning indicator lights with the ignition switch is ON.

If the light does not light, check the sub-fuse (10A) and wires for a loose connection or an open circuit.

Start the engine and make sure that the light goes out.

If the light does not go out, check the oil pressure (page 5-5).

If the oil pressure is normal, replace the oil pressure switch (page 5-5).

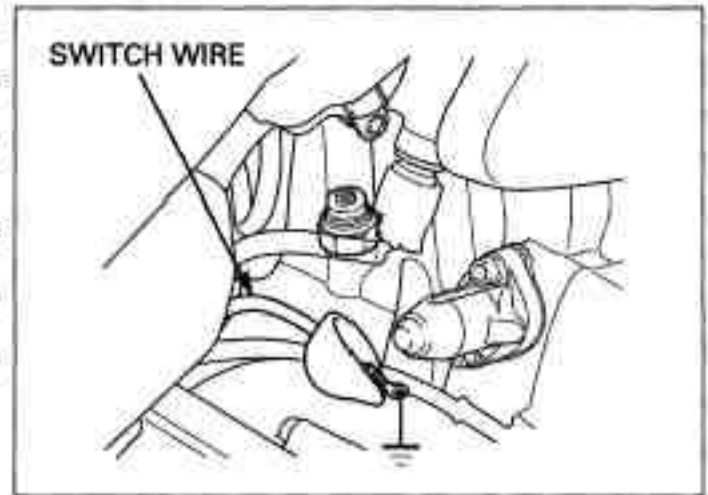

FUEL RESERVE SENSOR ('04 model)

SYSTEM INSPECTION

If the fuel reserve indicator does not indicate properly, check the following.

Remove the fuel tank (page 3-6).

Jump the Brown/black and Green/black wire terminals of the fuel reserve sensor 2P (Natural) connector wire harness side using a jumper wire.

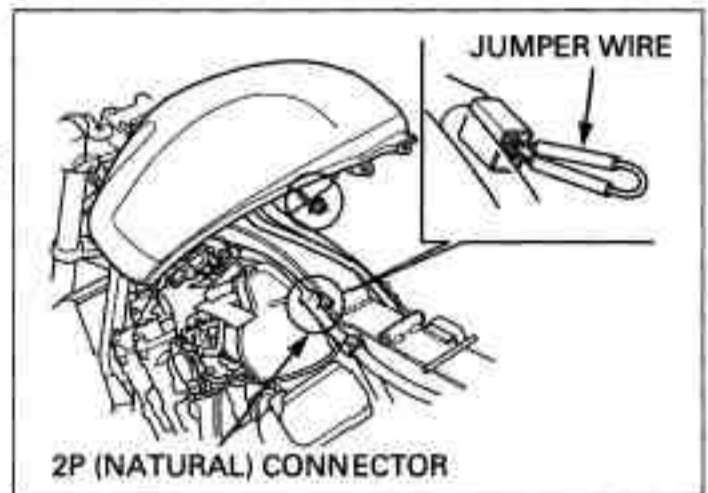

Turn the ignition switch to ON and make sure the fuel reserve indicator lights.

If the indicator lights, replace the fuel reserve sensor (page 20-23).

If the indicator still not light, check for open or short circuit in wire harness.

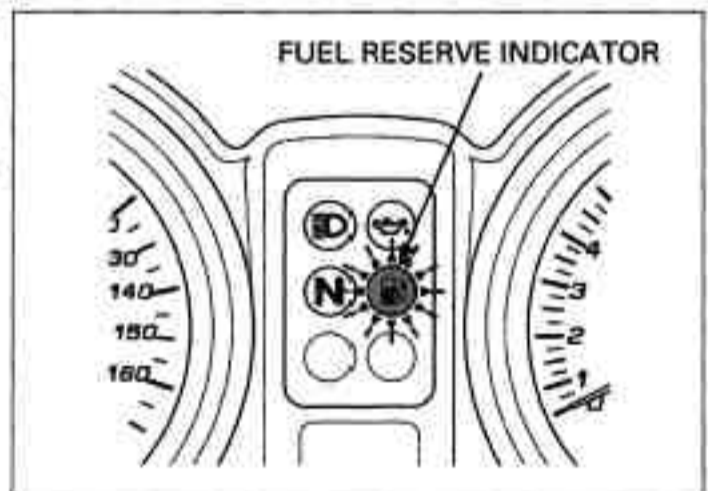

REMOVAL/INSTALLATION

Remove the fuel tank (page 3-6).

Remove the nuts, fuel reserve sensor and O-ring.

Be careful not to damage the reserve sensor arm.

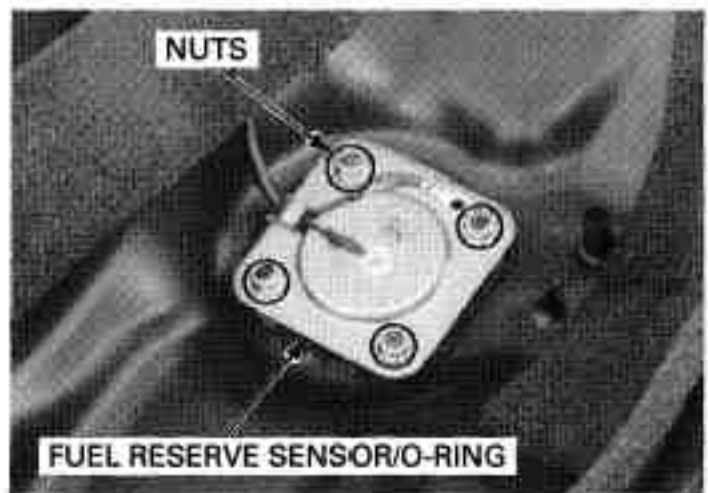

LIGHTS/METERS/SWITCHES

Check the fuel level sensor and arm for damage.
Replace if necessary.

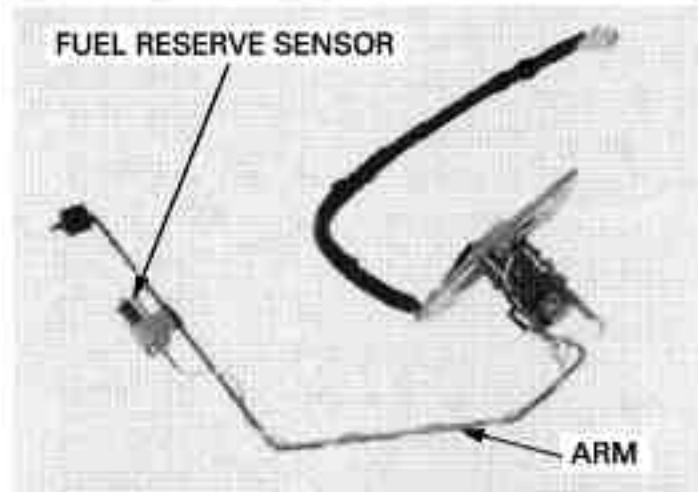

Check the O-ring is in good condition and replace if necessary.

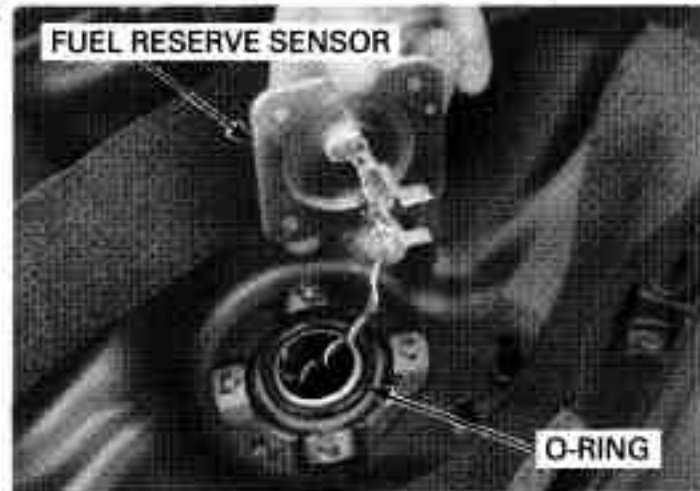

Be careful not to damage the reserve sensor arm.

Install the fuel reserve sensor into the fuel tank.
Installation is in the reverse order of removal.

FUEL LEVEL INDICATOR (After '04 model)

SYSTEM INSPECTION

OPEN CIRCUIT IN THE FUEL LEVEL SYSTEM

If the fuel level indicator indicates as shown in the right illustration, there are some open circuits in the fuel level indicator system. Check the open circuit as follows.

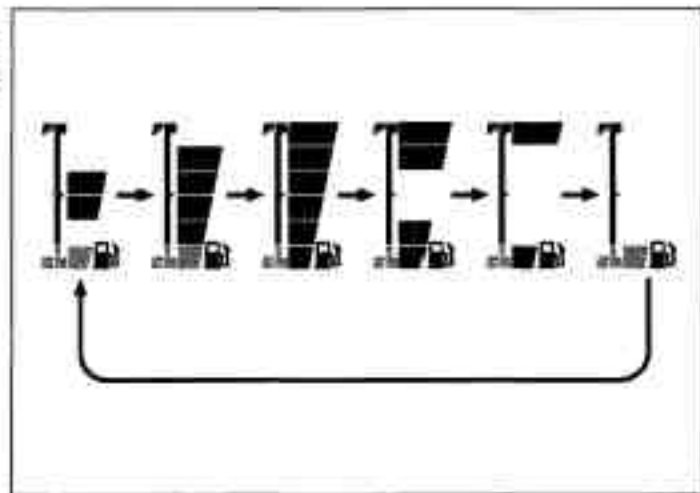

Remove the fuel tank (page 3-6).

Jump the Brown/Black and Green/Black wire terminals of the fuel level sensor 2P (Natural) connector with harness side using a jumper wire.

Turn the ignition switch to ON and check the fuel level indicator.

- If the fuel level indicator still indicates an open circuit indication, check the following.
 - Open circuit in the Green/black and Brown/black wire between the combination meter and the fuel level sensor
 - Faulty combination meter
- If the indicator indicates as "F", inspect the fuel level sensor.

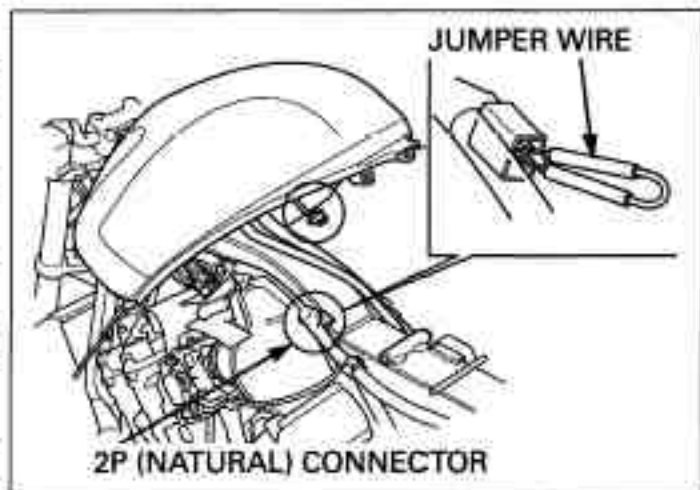

SHORT CIRCUIT IN THE FUEL LEVEL SYSTEM

If the fuel level indicator indicates this illustration (full fuel level) in spite of an empty fuel level, check the fuel level system for a short circuit.

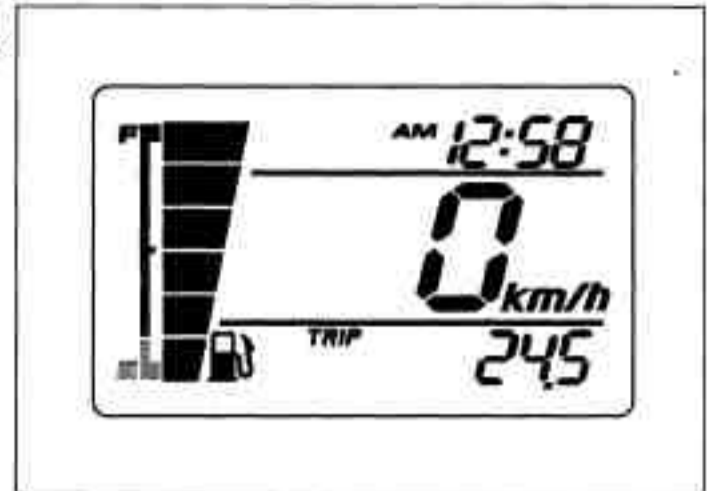

Remove the fuel tank (page 3-6).

Disconnect the fuel level sensor 2P (Natural) connector.

Turn the ignition switch to ON.

- If the fuel level indicator indicates an open circuit indication, inspect the fuel level sensor.
- If the indicator indicates as "F", check the following.
 - Short circuit in the Brown/black wire between the combination meter and the fuel level sensor
 - Faulty combination meter

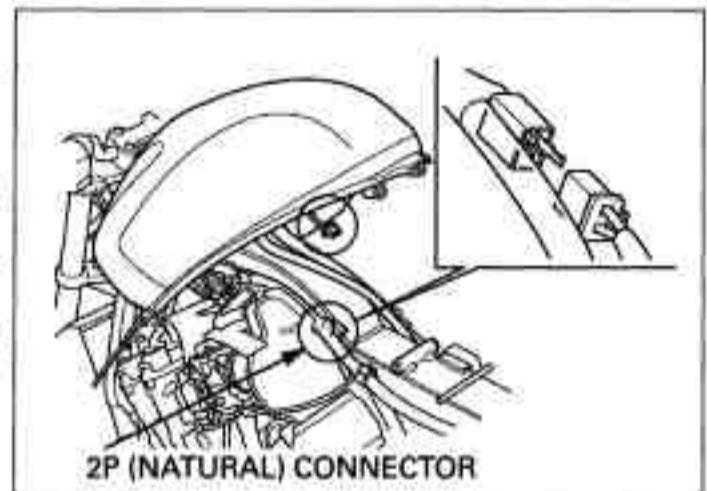

FUEL LEVEL SENSOR (After '04 model)

REMOVAL/INSTALLATION

Remove the fuel tank (page 3-6).

Be careful not to damage or bend the reserve sensor arm.

Remove the four nuts, fuel reserve sensor and O-ring.

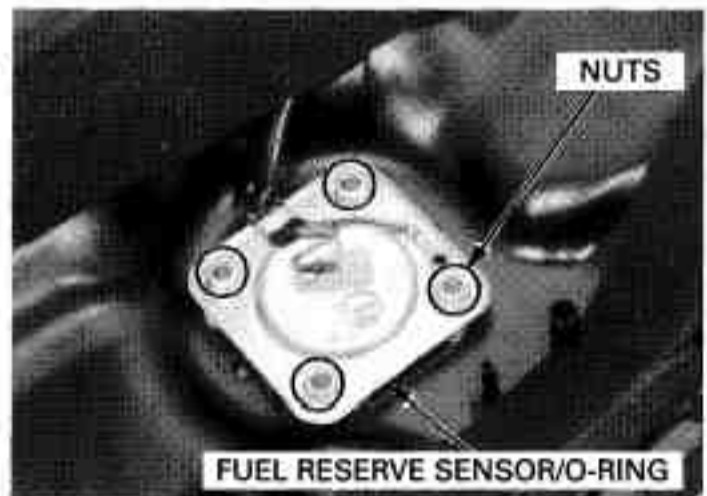

Check the O-ring is in good condition and replace if necessary.

Be careful not to damage the reserve sensor arm.

Install the fuel reserve sensor into the fuel tank. Installation is in the reverse order of removal.

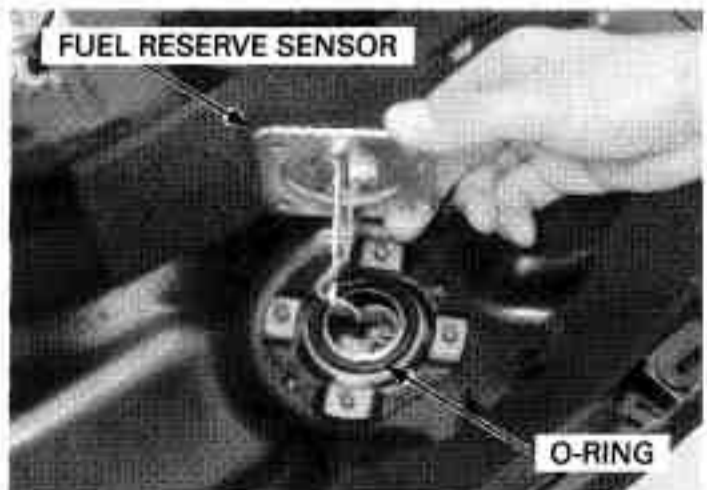

LIGHTS/METERS/SWITCHES

INSPECTION

Check the fuel level sensor and arm for damage.

Measure the resistance at the fuel level sensor 2P (Red) connector terminal with moving the float at the top "F" and bottom "E" position.

	TOP "F"	BOTTOM "E"
Resistance	5 - 7 Ω	204 - 210 Ω

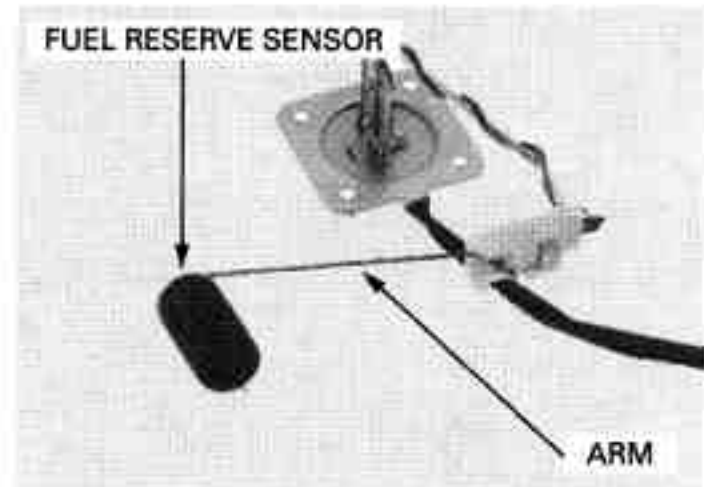

IGNITION SWITCH

INSPECTION

Remove the headlight unit (page 20-7).

Disconnect the ignition switch wire 4P (Natural) connector.

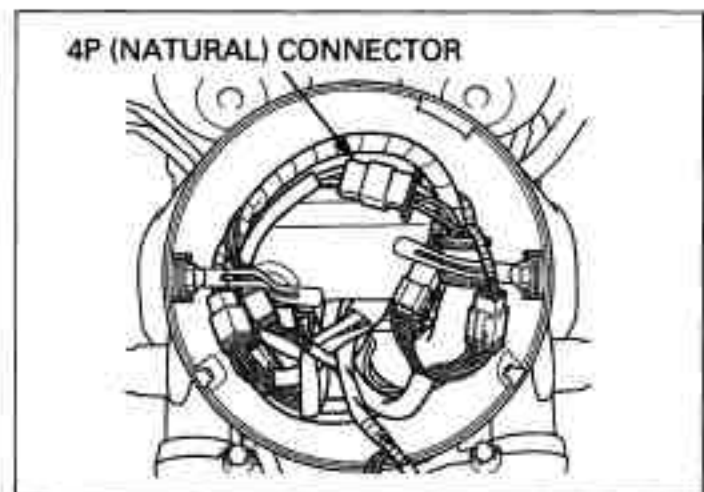

Check for continuity between the wire terminals of the ignition switch connector in each switch position.

Continuity should exist between the color coded wires as follows:

IGNITION SWITCH

	FAN	IG	BAT1	KEY
ON	○	○	○	KEY ON
OFF				KEY OFF
LOCK				KEY OFF LOCK PIN

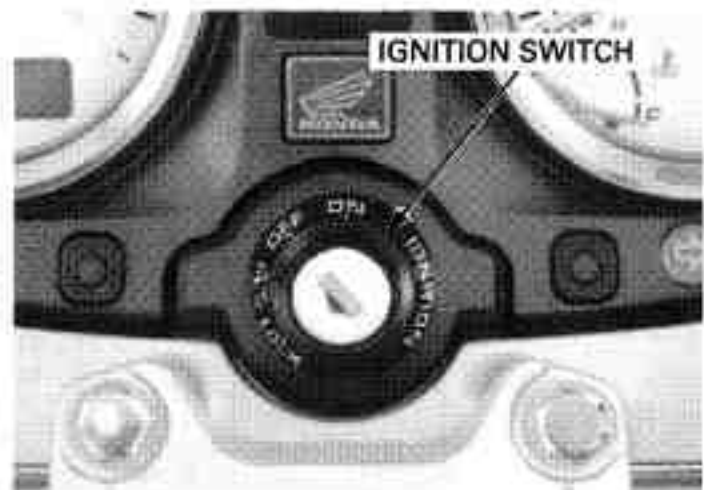

REMOVAL/INSTALLATION

Remove the headlight case (page 20-7).

Remove the bolts and ignition switch.

Install the ignition switch in the reverse order of removal.

Tighten the ignition switch mounting bolt to the specified torque.

TORQUE: 25 N·m (2.5 kgf·m, 18 lbf·ft)

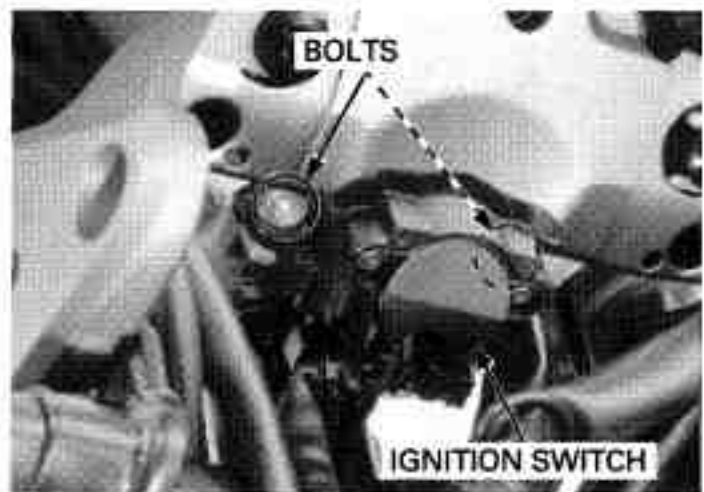

HANDLEBAR SWITCHES

Remove the headlight unit (page 20-7).

Disconnect the handlebar switch connectors.

Check for continuity between the wire terminals of the handlebar switch connector. Continuity should exist between the color coded wire terminals as follows:

ENGINE STOP SWITCH ('04 model)

	BAT2	IG2
○	○	○
⊗		

ENGINE STOP SWITCH (After '04 model)

	BAT3	IG2
○	○	○
⊗		

STARTER SWITCH

	ST	IG	HL	BAT4
FREE			○	○
PUSH	○	○		

TURN SIGNAL SWITCH ('04 model)

	W	R	L	P	PR	PL
R	○	○		○	○	○
N						
L	○	○	○	○	○	○

TURN SIGNAL SWITCH (After '04 model)

	W	R	L
R	○	○	
N			
L	○	○	○

HORN SWITCH ('04 model)

	Ho	BAT3
FREE		
PUSH	○	○

HORN SWITCH (After '04 model)

	Ho	BAT5
FREE		
PUSH	○	○

DIMMER SWITCHES

	HL	Lo	Hi
Lo			
Hi	○	○	○

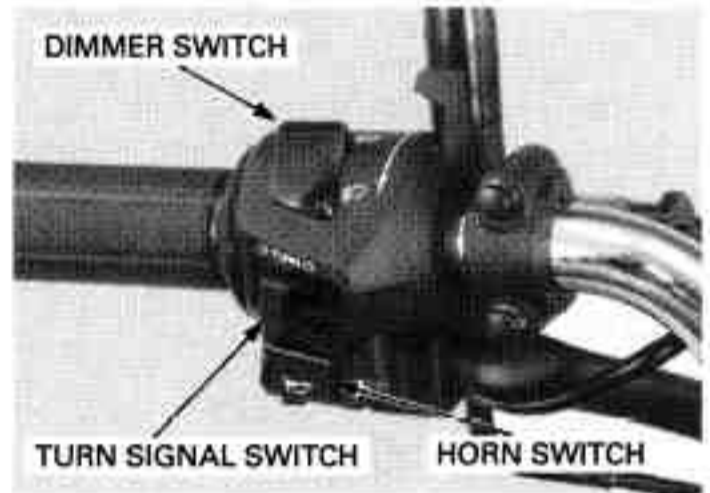
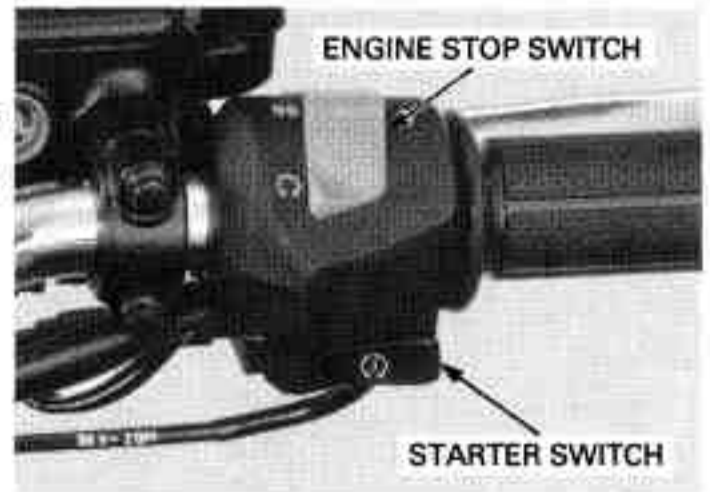

BRAKE LIGHT SWITCH

FRONT

Disconnect the front brake light switch connectors and check for continuity between the terminals.

There should be continuity with the brake lever applied, and there should be no continuity with the brake lever is released.

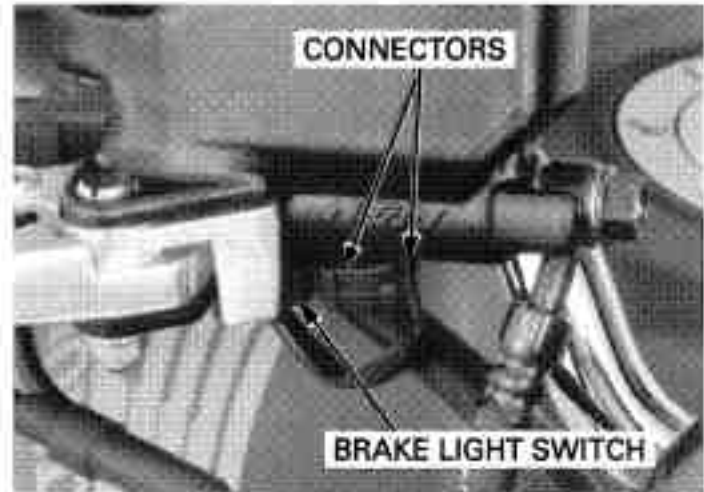

REAR

Remove the left side cover (page 3-4).

Disconnect the rear brake light switch 2P (Natural) connector and check for continuity between the terminals.

There should be continuity with the brake pedal applied, and there should be no continuity with the brake pedal is released.

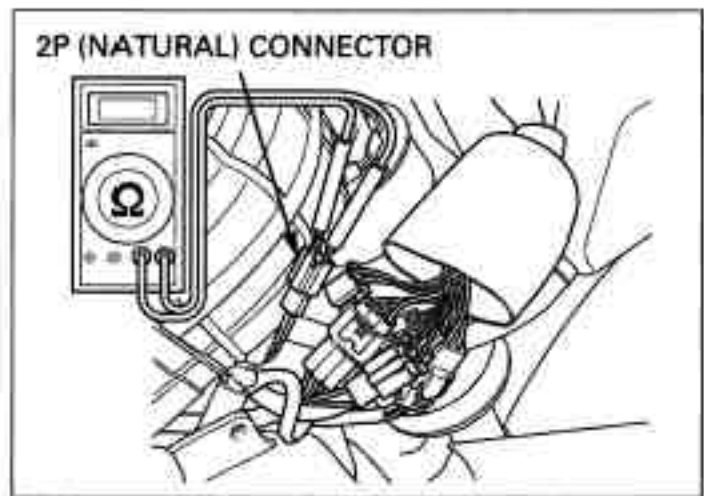

CLUTCH SWITCH

Disconnect the clutch switch connectors.

There should be continuity with the clutch lever applied, and there should be no continuity with the clutch lever is released.

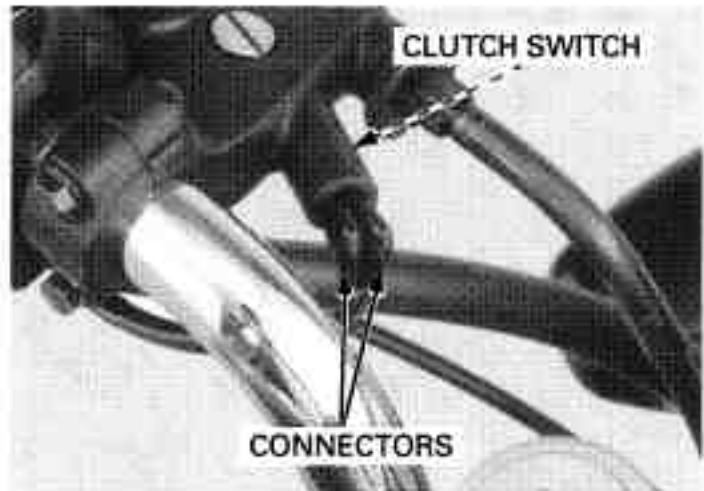

NEUTRAL SWITCH

INSPECTION

Remove the drive sprocket cover (page 8-4).

Disconnect the neutral switch connector from the switch.

Shift the transmission into neutral and check for continuity between the neutral switch terminal and ground.

There should be continuity with the transmission is in neutral, and no continuity when the transmission is into gear.

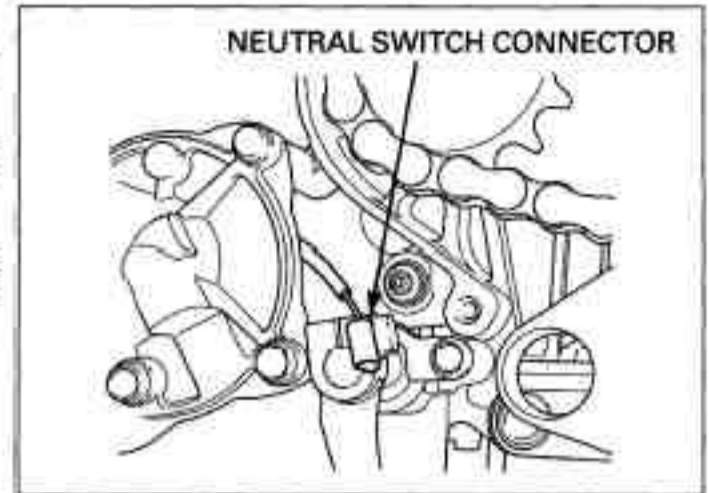

REMOVAL/INSTALLATION

Remove the drive sprocket cover (page 8-4).

Disconnect the neutral switch connector from the switch.

Remove the neutral switch and sealing washer.

Install the neutral switch with a new sealing washer. Tighten the neutral switch to the specified torque.

TORQUE: 12 N·m (1.2 kgf·m, 9 lbf·ft)

Connect the neutral switch connector to the switch.

Install the drive sprocket cover (page 8-7).

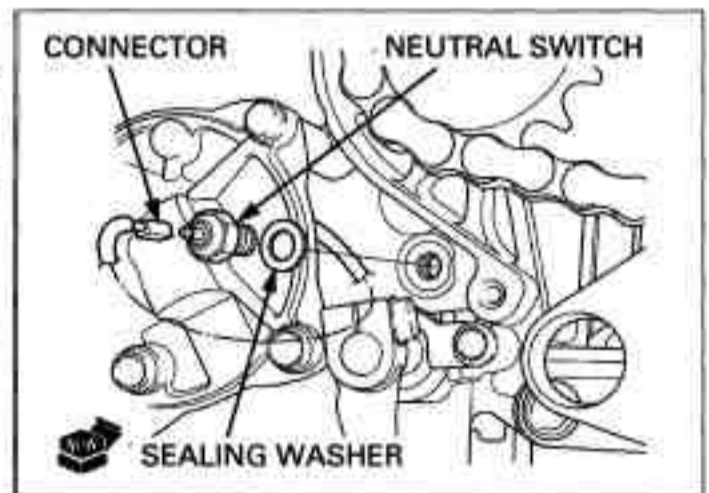

SIDE STAND SWITCH

INSPECTION

Remove the left side cover (page 3-4).

Disconnect the side stand switch 2P (Green) connector.

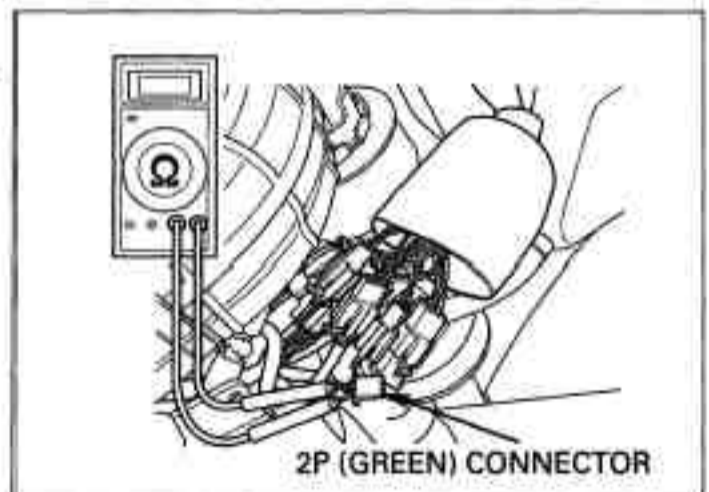

LIGHTS/METERS/SWITCHES

Check for continuity between the wire terminals of the side stand switch 2P (Green) connector. Continuity should exist only when the side stand is UP.

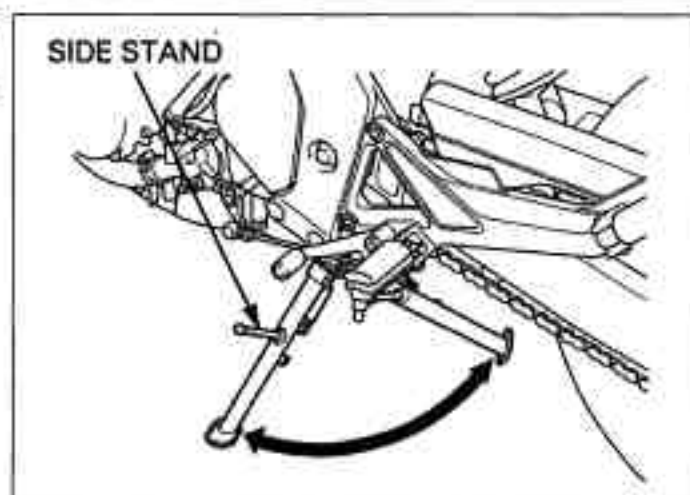

REMOVAL/INSTALLATION

Remove the left side cover (page 3-4).

Disconnect the side stand switch 2P (Green) connector.

Remove the bolt and side stand switch.

Install the side stand switch by aligning the switch pin with the side stand hole and the switch groove with the return spring holding pin.

Secure the side stand switch with a new bolt.

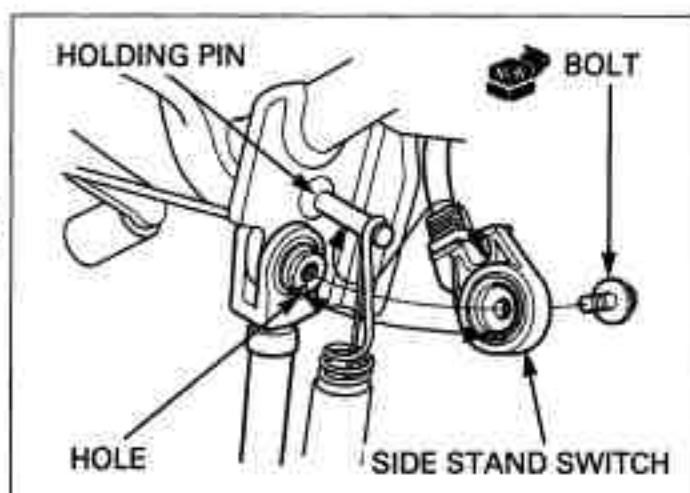

Connect the side stand switch 2P (Green) connector.

Install the left side cover (page 3-4).

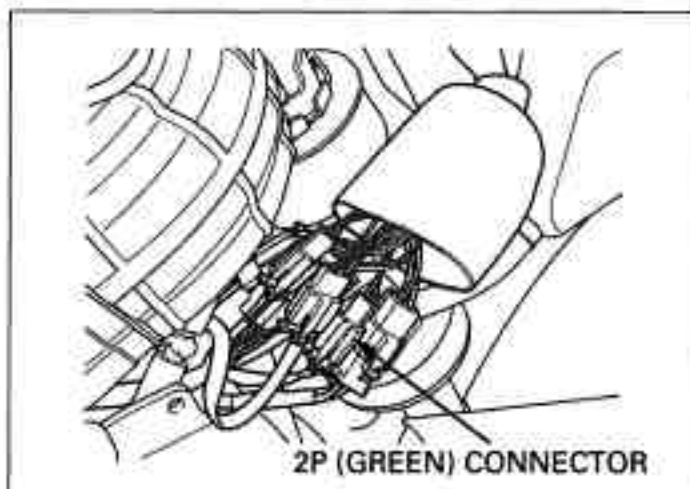

HORN

Disconnect the wire connectors from the horn.

Connect the 12V battery to the horn terminal directly.

The horn is normal if it sounds when the 12 V battery is connected across the horn terminals.

If the horn is abnormal, disconnect the wire connectors and remove the bolt, then replace the horn.

Installation is in the reverse order of removal.

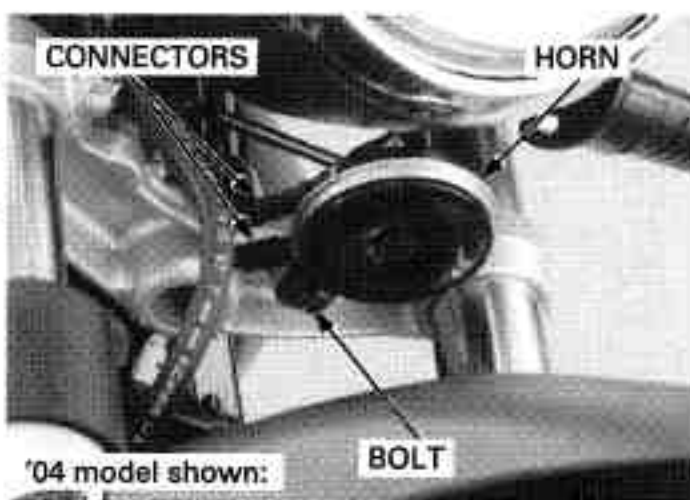

TURN SIGNAL RELAY

INSPECTION

1. Recommended Inspection

Check the following

- Battery condition
- Burned out bulb or non-specified wattage
- Burned fuse
- Ignition switch and turn signal switch function
- Loose connector

Check for the above items.

Are the above items in good condition?

YES - Replace or repair the malfunction part(s)

NO - GO TO STEP 2.

2. Turn Signal Circuit Inspection

Remove the rear cowl (page 3-5).

Disconnect the turn signal 3P (Black) connector from the relay.

Short the Black/brown and Gray terminals of the turn signal relay connector with a jumper wire. Start the engine and check the turn signal light by turning the switch ON.

Did the light come on?

YES - • Faulty turn signal relay
• Poor connection of the connector.

NO - Broken wire harness

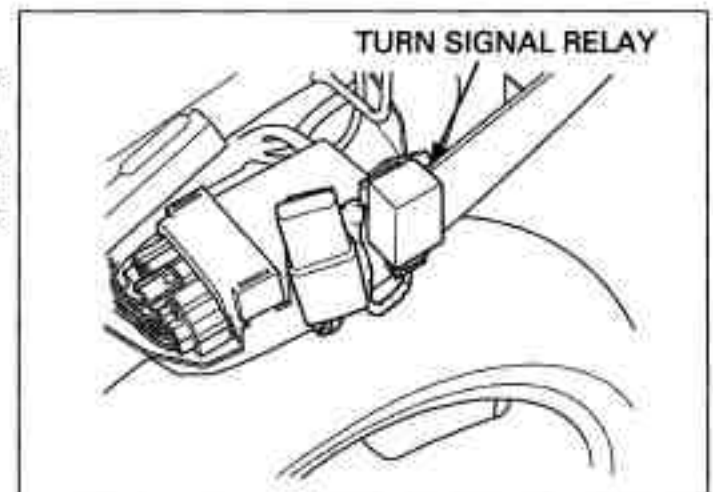

HEADLIGHT RELAY

Remove the rear cowl (page 3-5).

Disconnect the headlight relay 4P connector, then remove the headlight relay.

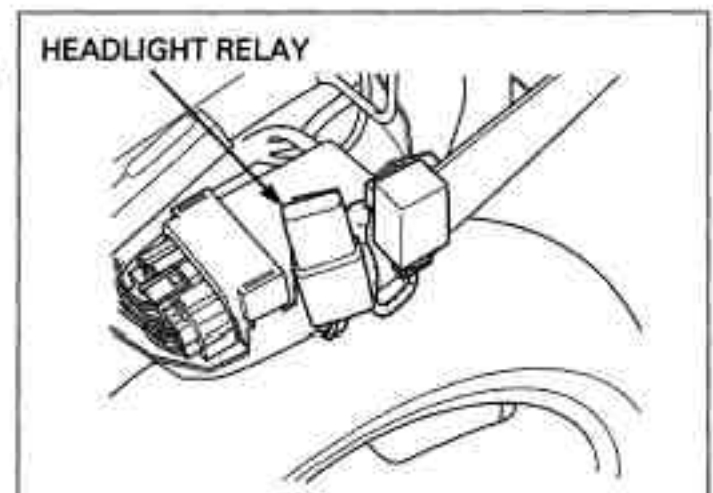

Connect the ohmmeter to the headlight relay connector terminals.

CONNECTION: Blue/black - Black/red

Connect the 12 V battery to the following headlight relay connector terminals.

CONNECTION: Blue - Green

There should be continuity when the 12 V battery is connected.

If there is no continuity when the 12 V battery is connected, replace the headlight relay.

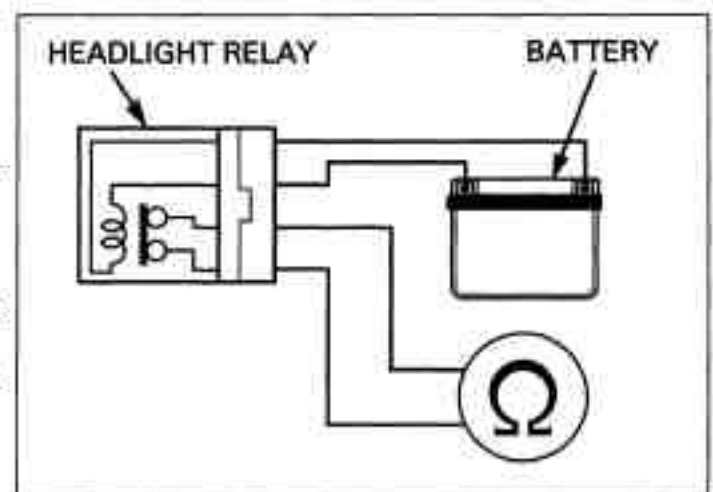

21. WIRING DIAGRAMS

WIRING DIAGRAM ('04 model) 21-3

WIRING DIAGRAM (After '04 model)21-4

WIRING DIAGRAM ('04 model)

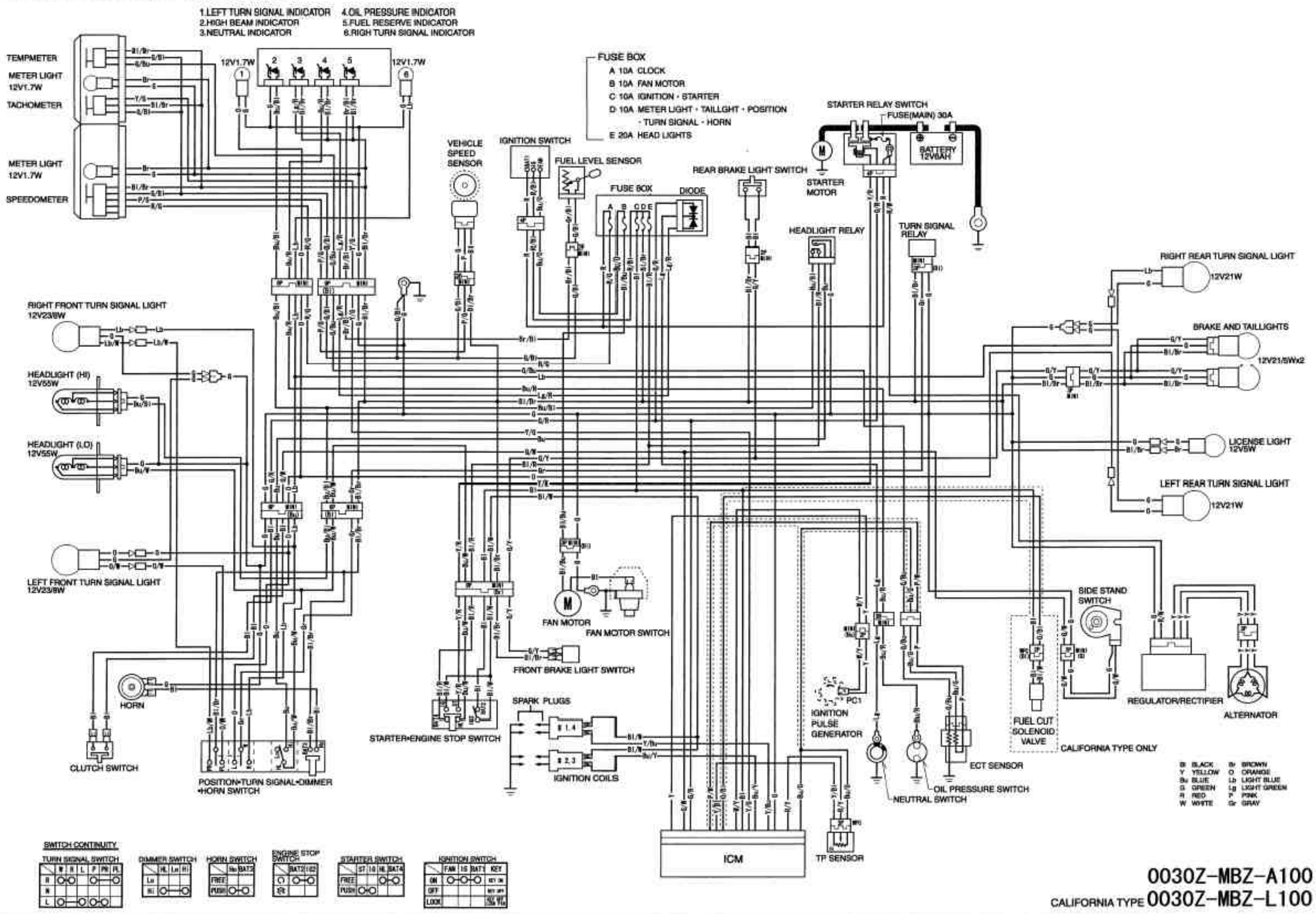

0030Z-MBZ-A100
 CALIFORNIA TYPE 0030Z-MBZ-L100

WIRING DIAGRAM (After '04 model)

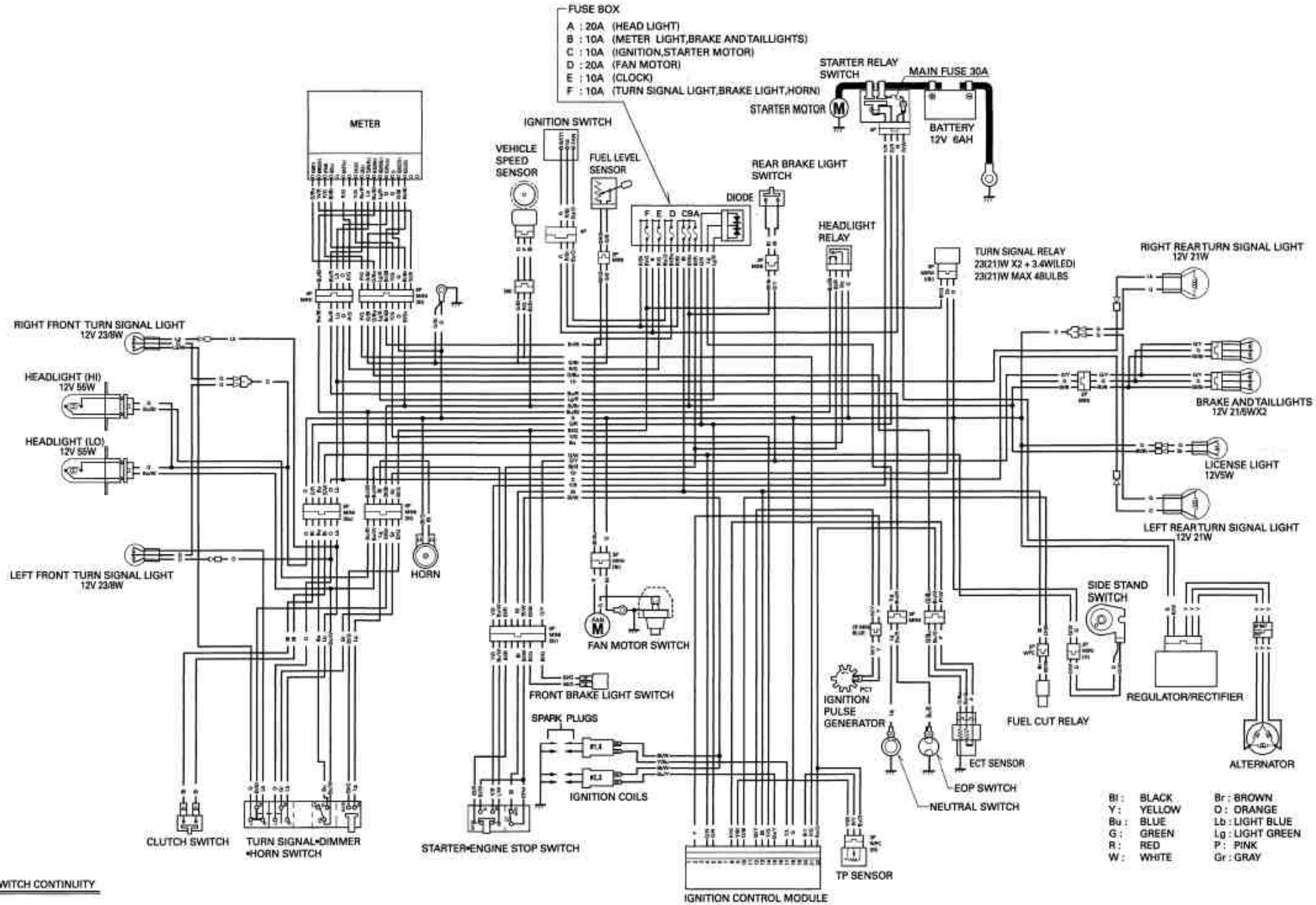

- Bl : BLACK
- Y : YELLOW
- Bu : BLUE
- G : GREEN
- R : RED
- W : WHITE
- Br : BROWN
- O : ORANGE
- Lb : LIGHT BLUE
- Lg : LIGHT GREEN
- P : PINK
- Gr : GRAY

SWITCH CONTINUITY

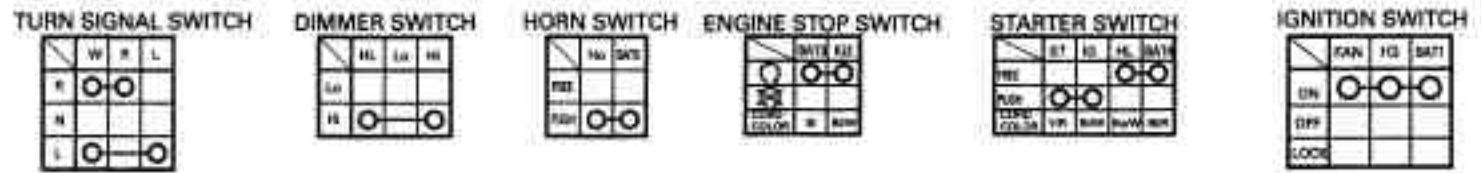

0030Z-MBZ-A400

22. TROUBLESHOOTING

ENGINE DOES NOT START OR IS HARD TO
START 22-2

ENGINE LACKS POWER 22-3

POOR PERFORMANCE AT LOW AND IDLE
SPEED22-5

POOR PERFORMANCE AT HIGH SPEED22-5

POOR HANDLING.....22-6

ENGINE DOES NOT START OR IS HARD TO START

1. Spark Plug Inspection

Remove and inspect spark plug.

Are the spark plugs in good condition?

- NO** – • Incorrect spark plug heat range
• Incorrect spark plug gap
• Dirty air cleaner

YES – GO TO STEP 2.

2. Spark Test

Perform spark test.

Are there good sparks?

- NO** – • Faulty spark plug
• Loose or disconnected ignition system wires
• Faulty ignition coil
• Broken or shorted spark plug wire
• Faulty ignition pulse generator
• Faulty engine stop switch
• Faulty ignition control module (ICM)

YES – GO TO STEP 3.

3. Fuel System Inspection

Check the fuel system.

Is the fuel system normal?

- NO** – Faulty fuel system.

YES – GO TO STEP 4.

4. Cylinder compression Inspection

Test the cylinder compression.

Is the compression as specified?

- NO** – • Valve stuck open
• Worn cylinder and piston rings
• Damaged cylinder head gasket
• Seized valve
• Improper valve timing

YES – GO TO STEP 5.

5. Engine Start Condition

Start by following normal procedure.

Did the engine start but stops?

- Yes** – • Leaking carburetor insulator
• Faulty starting enrichment (SE) valve
• Improper ignition timing (Faulty ICM or ignition pulse generator)
• Contaminated fuel

ENGINE LACKS POWER

1. Drive Train Inspection

Raise wheel off the ground and spin by hand.

Did the wheel spin freely?

- NO** – • Brake dragging
• Worn or damaged wheel bearings

YES – GO TO STEP 2.

2. Tire Pressure Inspection

Check the tire pressure.

Are the tire pressures correct?

- NO** – • Faulty tire valve
• Punctured tire

YES – GO TO STEP 3.

3. Clutch Inspection

Accelerate rapidly low to second.

Did the engine speed change accordingly when clutch is released?

- NO** – • Clutch slipping
• Worn clutch discs/plates
• Warped clutch discs/plates
• Weak clutch spring
• Additive in engine oil

YES – GO TO STEP 4.

4. Engine Performance Inspection

Accelerate lightly.

Did the Engine speed increase?

- NO** – • Starting enrichment (SE) valve ON position
• Clogged air cleaner
• Restricted fuel flow
• Pinched fuel tank breather
• Clogged muffler

YES – GO TO STEP 5.

5. Spark Plug Inspection

Remove and inspect spark plug.

Are the spark plugs in good condition?

- NO** – • Plugs not serviced frequently enough
• Incorrect spark plug heat range
• Incorrect spark plug gap

YES – GO TO STEP 6.

6. Engine Oil Inspection

Check the oil level and condition.

Is the engine oil good condition?

- NO** – • Oil level too high
• Oil level too low
• Contaminated oil

YES – GO TO STEP 7.

7. Ignition Timing Inspection

Check the ignition timing.

Is the ignition timing as specified?

- NO** – • Faulty ignition control module (ICM)
• Faulty ignition pulse generator

YES – GO TO STEP 8.

TROUBLESHOOTING

8. Cylinder compression inspection

Test the cylinder compression.

Is the compression as specified?

- NO** – • Valve clearance too small
• Worn cylinder and piston rings
• Damaged cylinder head gasket
• Improper valve timing

YES – GO TO STEP 9.

9. Fuel System Inspection

Check the fuel system.

Is the fuel system normal?

NO – Faulty fuel system.

YES – GO TO STEP 10.

10. Lubrication Inspection

Remove cylinder head cover and inspect lubrication.

Is the Valve train lubricated properly?

- NO** – • Oil level too low
• Faulty oil pump
• Plugged oil gallery

YES – GO TO STEP 11.

11. Over Heating Inspection

Check for engine over heating.

Is the engine over heating?

- YES** – • Coolant level too low
• Fan motor not working (Faulty fan motor switch)
• Thermostat stuck closed
• Excessive carbon build-up in combustion chamber
• Use of poor quality fuel
• Lean fuel mixture
• Wrong type of fuel
• Clutch slipping

NO – GO TO STEP 12.

12. Engine Knocking Inspection

Accelerate or run at high speed.

Is the engine knocking?

- YES** – • Worn piston and cylinder
• Wrong type of fuel
• Thermostat stuck closed
• Excessive carbon build-up in combustion chamber
• Ignition timing too advance (Faulty ICM)

NO – • Engine does not knock

POOR PERFORMANCE AT LOW AND IDLE SPEED

1. Spark Plug Inspection

Remove and inspect spark plug.

Are the spark plugs in good condition?

NO – • Plugs not serviced frequently enough
• Incorrect spark plug heat range
• Incorrect spark plug gap

YES – GO TO STEP 2.

2. Ignition Timing Inspection

Check the ignition timing.

Is the ignition timing as specified?

NO – • Faulty ignition control module (ICM)
• Faulty ignition pulse generator

YES – GO TO STEP 3.

3. Fuel System Inspection

Check the fuel system.

Is the fuel system normal?

NO – Faulty fuel system.

YES – GO TO STEP 4.

4. Starter Valve Synchronization Inspection

Check the starter valve synchronization.

Is the starter valve synchronization as specified?

NO – Adjust the starter valve synchronization.

YES – GO TO STEP 5.

5. Intake Manifold Leaking Inspection

Check for leaks at the carburetor insulator.

Is there leaking?

YES – • Loose insulator
• Damaged insulator

POOR PERFORMANCE AT HIGH SPEED

1. Ignition Timing Inspection

Check the ignition timing.

Is the ignition timing as specified?

NO – • Faulty ignition control module (ICM)
• Faulty ignition pulse generator

YES – GO TO STEP 2.

2. Fuel System Inspection

Check the fuel system.

Is the fuel system normal?

NO – Faulty fuel system.

YES – GO TO STEP 3.

3. Valve Timing Inspection

Check the valve timing.

Is the valve timing correct?

NO – Camshafts not installed properly

YES – GO TO STEP 4.

TROUBLESHOOTING

4. Valve Spring Inspection

Check the valve springs.

Is the valve spring free length as specified?

NO – Faulty valve spring

YES – Not weak

POOR HANDLING

Steering is heavy

- Steering bearing adjustment nut too tight
- Damaged steering head bearings

Either wheel is wobbling

- Excessive wheel bearing play
- Bent rim
- Improper installed wheel hub
- Swingarm pivot bearing excessively worn
- Bent frame

The motorcycle pulls to one side

- Front and rear wheel not aligned
- Faulty shock absorber
- Bent fork
- Bent swingarm
- Bent axle
- Bent frame

AIR CLEANER	4-6	CYLINDER HEAD INSTALLATION	9-24
AIR CLEANER HOUSING	6-7	CYLINDER HEAD REMOVAL	9-12
ALTERNATOR CHARGING COIL	17-8	CYLINDER HEAD/VALVES SPECIFICATIONS	1-8
ALTERNATOR COVER INSTALLATION	11-11	DIODE	19-15
ALTERNATOR COVER REMOVAL	11-4	DRIVE CHAIN	4-23
ALTERNATOR/STARTER CLUTCH SPECIFICATIONS ..	1-8	ELECTRIC STARTER SPECIFICATIONS	1-11
BATTERY	17-6	EMISSION CONTROL INFORMATION LABELS	1-51
BATTERY/CHARGING SYSTEM SPECIFICATIONS	1-11	EMISSION CONTROL SYSTEMS	1-48
BODY PANEL LOCATIONS	3-2	ENGINE & FRAME TORQUE VALUES	1-13
BRAKE FLUID	4-27	ENGINE IDLE SPEED	4-21
BRAKE FLUID REPLACEMENT/AIR BLEEDING	16-6	ENGINE INSTALLATION	8-7
BRAKE LIGHT SWITCH		ENGINE OIL/OIL FILTER	4-14
LIGHTS/METERS/SWITCHES	20-28	ENGINE REMOVAL	8-4
MAINTENANCE	4-29	EVAPORATIVE EMISSION CONTROL SYSTEM	4-23
BRAKE PAD WEAR	4-28	EVAPORATIVE EMISSION CONTROL SYSTEM	
BRAKE PAD/DISC	16-9	(California type only)	6-39
BRAKE PEDAL	16-32	FLYWHEEL INSTALLATION	11-10
BRAKE SYSTEM	4-29	FLYWHEEL REMOVAL	11-6
CABLE & HARNESS ROUTING	1-23	FORK	14-21
CAM CHAIN TENSIONER LIFTER	9-32	FRONT BRAKE CALIPER	16-24
CAMSHAFT INSTALLATION	9-27	FRONT FENDER ('04 model)	3-7
CAMSHAFT REMOVAL	9-7	FRONT FENDER (After '04 model)	3-7
CARBURETOR ASSEMBLY	6-20	FRONT MASTER CYLINDER	16-12
CARBURETOR CHOKE	4-6	FRONT WHEEL	14-15
CARBURETOR COMBINATION	6-25	FRONT WHEEL/SUSPENSION/STEERING	
CARBURETOR DISASSEMBLY	6-15	SPECIFICATIONS	1-10
CARBURETOR INSTALLATION	6-34	FUEL CUTOFF SOLENOID VALVE	2-2
CARBURETOR REMOVAL	6-10	FUEL LEVEL INDICATOR (After '04 model)	20-24
CARBURETOR SEPARATION	6-12	FUEL LEVEL SENSOR (After '04 model)	20-25
CARBURETOR SYNCHRONIZATION ('04 model)	4-17	FUEL LINE	4-5
CARBURETOR SYNCHRONIZATION		FUEL RESERVE SENSOR	20-23
(After '04 model)	4-19	FUEL SYSTEM	1-7
CHARGING SYSTEM INSPECTION	17-7	FUEL TANK	3-6
CLUTCH	10-7	FUEL VALVE	6-44
CLUTCH SWITCH	20-28	GEARSHIFT LINKAGE	10-15
CLUTCH SYSTEM	4-30	GENERAL SPECIFICATIONS	1-5
CLUTCH/GEARSHIFT LINKAGE SPECIFICATIONS	1-8	HANDLEBAR	14-8
COMBINATION METER ('04 model)	20-9	HANDLEBAR SWITCHES	20-27
COMBINATION METER (After '04 model)	20-13	HEADLIGHT	20-6
COMPONENT LOCATION		HEADLIGHT AIM	4-30
ALTERNATOR/STARTER CLUTCH	11-2	HEADLIGHT RELAY	20-31
CLUTCH/GEARSHIFT LINKAGE	10-2	HIGH ALTITUDE ADJUSTMENT	6-36
CRANKCASE/TRANSMISSION	12-2	HORN	20-30
CRANKSHAFT/PISTON/CYLINDER	13-2	HYDRAULIC BRAKE SPECIFICATIONS	1-11
CYLINDER HEAD/VALVES	9-2	IGNITION COIL	18-10
ENGINE REMOVAL/INSTALLATION	8-2	IGNITION CONTROL MODULE (ICM)	18-12
FRONT WHEEL/SUSPENSION/STEERING	14-2	IGNITION PULSE GENERATOR	18-7
FUEL SYSTEM	6-2	IGNITION SWITCH	20-26
HYDRAULIC BRAKE	16-2	IGNITION SYSTEM INSPECTION	18-5
REAR WHEEL SUSPENSION	15-2	IGNITION SYSTEM SPECIFICATIONS	1-11
COOLANT REPLACEMENT	7-6	IGNITION TIMING	18-12
COOLANT TEMPERATURE GAUGE/SENSOR	20-19	LICENSE LIGHT	20-9
COOLING FAN MOTOR SWITCH	20-21	LIGHTS/METERS/SWITCHES SPECIFICATION	
COOLING SYSTEM	4-21	('04 model)	1-12
COOLING SYSTEM SPECIFICATIONS	1-7	LIGHTS/METERS/SWITCHES SPECIFICATION	
CRANKCASE ASSEMBLY	12-14	(After '04 model)	1-12
CRANKCASE SEPARATION	12-5	LUBRICATION & SEAL POINTS	1-19
CRANKCASE/TRANSMISSION SPECIFICATIONS	1-9	LUBRICATION SYSTEM DIAGRAM	5-2
CRANKPIN BEARING	13-10	LUBRICATION SYSTEM SPECIFICATIONS	1-7
CRANKSHAFT	13-5	MAIN JOURNAL BEARING	13-7
CRANKSHAFT/PISTON/CYLINDER SPECIFICATIONS ..	1-9	MAINTENANCE SCHEDULE	4-4
CYLINDER COMPRESSION TEST	9-6	METER VISOR (After '04 model)	3-8
CYLINDER HEAD ASSEMBLY	9-22	MODEL IDENTIFICATION	1-2
CYLINDER HEAD COVER ASSEMBLY	9-30	MUFFLER/EXHAUST PIPE	3-9
CYLINDER HEAD COVER DISASSEMBLY	9-7	NEUTRAL SWITCH	20-29
CYLINDER HEAD COVER INSTALLATION	9-31	NUTS, BOLTS, FASTENERS	4-32
CYLINDER HEAD COVER REMOVAL	9-6	OIL COOLER	5-14
CYLINDER HEAD DISASSEMBLY	9-15	OIL PRESSURE INSPECTION	5-5
CYLINDER HEAD INSPECTION	9-16	OIL PRESSURE SWITCH	20-22

INDEX

OIL PUMP	5-8	STATOR	11-5
OIL STRAINER/PRESSURE RELIEF VALVE	5-6	STEERING HEAD BEARINGS	4-33
PAIR REED VALVE	9-34	STEERING STEM	14-41
PILOT SCREW ADJUSTMENT	6-35	SUSPENSION	4-31
PISTON/CYLINDER	13-12	SWINGARM	15-15
RADIATOR	7-10	SYSTEM DIAGRAM	
RADIATOR COOLANT	4-21	BATTERY/CHARGING SYSTEM	17-2
RADIATOR RESERVE TANK	7-16	ELECTRIC STARTER	19-2
REAR BRAKE CALIPER	16-28	IGNITION SYSTEM	18-2
REAR COWL	3-5	SYSTEM FLOW PATTERN	7-2
REAR FENDER	3-8	SYSTEM LOCATION	
REAR MASTER CYLINDER	16-18	LIGHTS/METERS/SWITCHES	20-2
REAR WHEEL	15-6	SYSTEM TESTING	7-5
REAR WHEEL/SUSPENSION SPECIFICATIONS	1-10	TACHOMETER	20-18
REGULATOR/RECTIFIER	17-9	TAIL/BRAKE LIGHT	20-8
RIGHT CRANKCASE COVER INSTALLATION	10-18	THERMOSTAT	7-8
RIGHT CRANKCASE COVER REMOVAL	10-6	THROTTLE OPERATION	4-5
SEAT	3-4	TP SENSOR	18-10
SECONDARY AIR SUPPLY SYSTEM		TRANSMISSION	12-8
FUEL SYSTEM	6-37	TROUBLESHOOTING	
MAINTENANCE	4-22	ALTERNATOR/STARTER CLUTCH	11-3
SERVICE INFORMATION		BATTERY/CHARGING SYSTEM	17-5
ALTERNATOR/STARTER CLUTCH	11-3	CLUTCH/GEARSHIFT LINKAGE	10-5
BATTERY/CHARGING SYSTEM	17-3	COOLING SYSTEM	7-4
CLUTCH/GEARSHIFT LINKAGE	10-3	CRANKCASE/TRANSMISSION	12-4
COOLING SYSTEM	7-3	CRANKSHAFT/PISTON/CYLINDER	13-4
CRANKCASE/TRANSMISSION	12-3	CYLINDER HEAD/VALVES	9-5
CRANKSHAFT/PISTON/CYLINDER	13-3	ELECTRIC STARTER	19-4
CYLINDER HEAD/VALVES	9-3	ENGINE DOES NOT START OR IS HARD TO	
ELECTRIC STARTER	19-3	START	22-2
ENGINE REMOVAL/INSTALLATION	8-3	ENGINE LACKS POWER	22-3
FRAME/BODY PANELS/EXHAUST SYSTEM	3-3	FRAME/BODY PANELS/EXHAUST SYSTEM	3-3
FRONT WHEEL/SUSPENSION/STEERING	14-4	FRONT WHEEL/SUSPENSION/STEERING	14-6
FUEL SYSTEM	6-4	FUEL SYSTEM	6-6
HYDRAULIC BRAKE	16-4	HYDRAULIC BRAKE	16-5
IGNITION SYSTEM	18-3	IGNITION SYSTEM	18-4
LIGHTS/METERS/SWITCHES	20-3	LIGHTS/METERS/SWITCHES	20-5
LUBRICATION SYSTEM	5-3	LUBRICATION SYSTEM	5-4
MAINTENANCE	4-2	POOR HANDLING	22-6
REAR WHEEL SUSPENSION	15-3	POOR PERFORMANCE AT HIGH SPEED	22-5
SERVICE RULES	1-2	POOR PERFORMANCE AT LOW AND IDLE SPEED	22-5
SHIFT FORK/SHIFT DRUM	12-6	REAR WHEEL SUSPENSION	15-5
SHOCK ABSORBER	15-13	TURN SIGNAL	20-7
SIDE COVER	3-4	TURN SIGNAL RELAY	20-31
SIDE STAND	4-31	VALVE CLEARANCE	4-9
SIDE STAND SWITCH	20-29	VALVE GUIDE REPLACEMENT	9-18
SPARK PLUG	4-7	VALVE SEAT INSPECTION/REFACING	9-19
SPEEDOMETER/VEHICLE SPEED SENSOR	20-15	WATER PUMP	7-17
STANDARD TORQUE VALUES	1-13	WHEELS/TIRES	4-33
STARTER CLUTCH	11-7	WIRING DIAGRAM ('04 model)	21-3
STARTER MOTOR	19-6	WIRING DIAGRAM (After '04 model)	21-4
STARTER RELAY SWITCH	19-14		